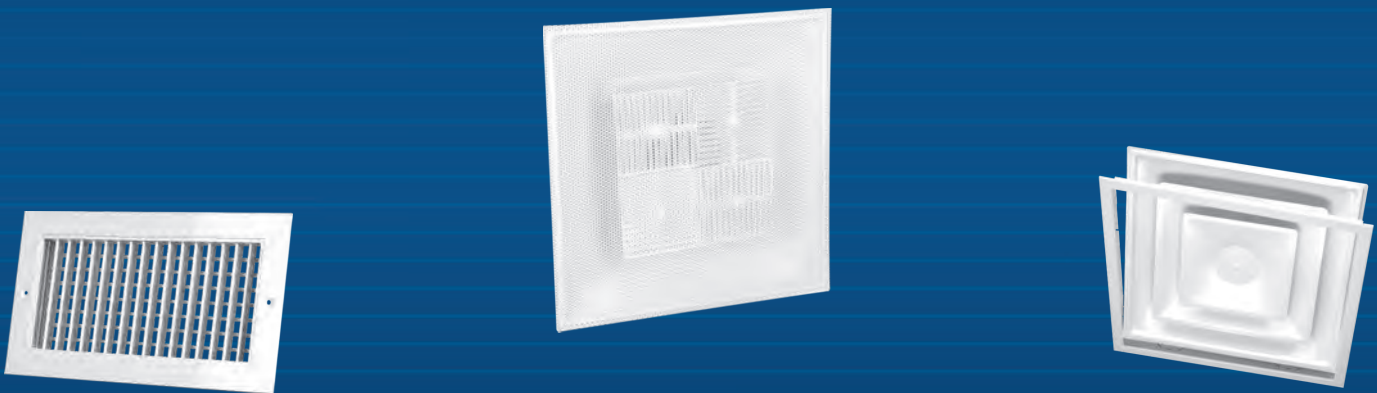




AIRVECTOR®

Quality Air Distribution Products



Technical Catalog



Updates available online at www.airvector-hvac.com

Pricing and delivery service information

Shipping plan	Premium
 <p>0 Day Ship <i>Guaranteed ships on SAME day</i></p>	<p>Net price + 10% Orders up to 500\$. Only DF3, DF4, ISO & All GSA / GAA white or mill, even sizes up to 36" x 18". No odd or fractional sizes. Cut-off time: 11 a.m.</p>
 <p>2 Day Ship <i>Guaranteed ships 2 days later</i></p>	<p>Net price + 10% Orders up to 2,500\$. Only DF3, DF4, ISO & All GSA / GAA white or mill, even sizes up to 36" x 18". No odd or fractional sizes.</p>
 <p>5 Day Ship <i>Guaranteed ships 5 days later</i></p>	<p>Net price + 10% Same products as 2-day ship, for orders more than 2,500\$. & All orders of other standard products not included in 2-day ship premium services.</p>
 <p>Standard <i>2-3 weeks</i></p>	<p>Net price No premium Full line of products, standard or not.</p>

*Shipping plans are based on working days
Allow for additional freight time to lead times above*



Should Airvector® miss a Same-Day, a 2-DAY or a 5-DAY SHIP due to our error, **we will completely reimburse your order.**

To avoid delays, please include all required information on purchase orders.

Special requirements? Let us know

Special labeling, bar coding, tagging orders, special designs, faster delivery...

Minimum invoice (before shipping cost)	FOB
\$40	Our plant

Important Information

- Shipping plans are available only for standard products. Please check with Order Desk for availability of a product for quick ship.
- Shipping plan premium will be automatically applied based on requested shipping date.
- Orders received after 2 p.m. (Eastern time) will be considered as following working day. For same-day orders, cut-off time is 11 a.m.
- Airvector® will determine how to ship if not specified by client.
- Contact factory for estimated shipping cost.
- Confirm orders in writing. Buyer assumes full responsibility for any errors on verbal orders.
- Extra crating, if needed, will be additional. Customer's approval required.
- Returned goods must be pre-approved. Standard restocking charge of 25% (exclusive of return freight costs) on resalable goods only. Judgment whether goods are resalable or not are at the discretion of Alfa Mega Inc. or Airvector Inc.
- We will accept Freight Damage claims in the thirty (30) days following shipping. Any claims submitted after this date will be disregarded. To submit a claim, please attach the shipper's signed copy of the Bill of Lading pertaining to the invoice.
- Default finish is White for most products. Other colors available upon request, please contact factory and see finish chart.
- Products that show manufacturing defects will be replaced or refurbished free of charge.

Cancellation rules

Changes or Returns	Non Resaleable Items		Resaleable Items <small>(check with factory)</small>	
	Non Premium	Premium	Non Premium	Premium
0 to 24 hours	No Fee	No Fee	No Fee	No Fee
1 to 3 Days	25% fee	100% fee	25% fee	25% fee
3 Days or more	100% fee	100% fee	25% fee	25% fee

Important note

When an item is changed after 24 hours, the original item will be shipped unless requested to be scrapped by customer. Scrapping will be done as a “no charge” service.

General procedure

Upon order modification:

Generally between 0-24 hours, production is not yet started, so the order quantities can be canceled and modified at will. However, when a new item is ordered it is automatically a new PO using the same number as the original adding -1 as a suffix (please note that the min. order surcharge applies).

Procedure when an order falls under the 25% fee rule

Upon receiving the instruction to modify or cancel:

- When an item is canceled, we type “CANCELED” in the beginning of the description. Price is modified to 25% of the original value.
- When an item is modified, the current item is canceled (see previous for canceled items) and a new item is ordered in a new PO-1.
- When an item quantity is reduced, we need to split the item on 2 lines of the PO. The first line with the final quantity, the second with the canceled quantity (see previous for canceled items).

Our new products!

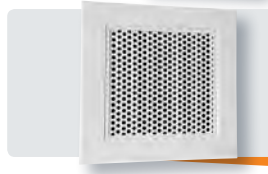
New Grilles



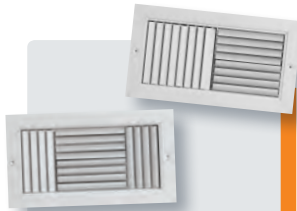
GADA, GADS,
GADC
Door Grilles



FGSA/FERE
Filter
Grilles



PRE
Perforated
Grille



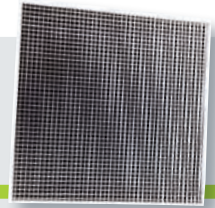
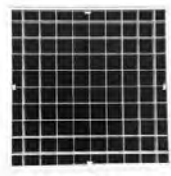
GCB1, GCB2,
GCB3, GCB4
3 & 4 Way Curved
Blade Grilles



ERE1: 1/2" x 1/2" x 1"
ERE3: 1"x1"x1"
ERE5: 45° angled
Eggcrate Grilles

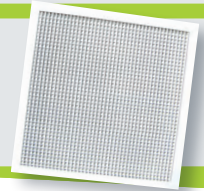
New Return Products

ERT1,
ERU1, ERN1
1/2" x 1/2" x 1"

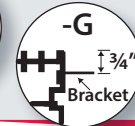
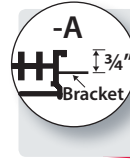


ERT3,
ERU3, ERN3
1"x1"x1"

ERT5,
ERU5, ERN5
45° angled



New Linear Options



Mounting Brackets
for Sheetrock -SB

New Diffusers & Options

New Diffusers



ISA
Adjustable Plaque
Diffusers

NEG (round),
NES (square)
Equalizing
Grids for DF3/DF4



DRV
Supply & Exhaust
Valve Diffusers

New Options



• Plaque Option PQ

• Hi induction for
Swirl Effect



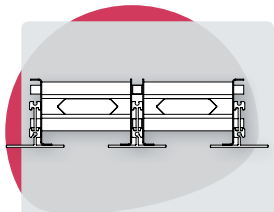
Panel Options
Available for:
DF3, DF4, GSA,
DLA, PRE, GCR

Our R&D
department
has been on
a rampage
this year!

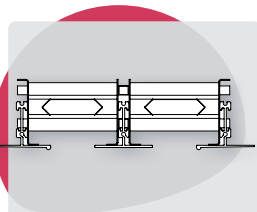
Try these new
products on
quotes or call
us for prices!

Our new products

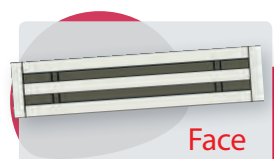
|Linear Flow Bar



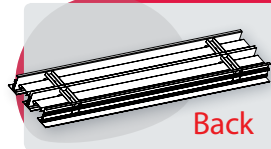
ALF-E
Standard Frame



ALF-P
Plaster-in Frame



Face



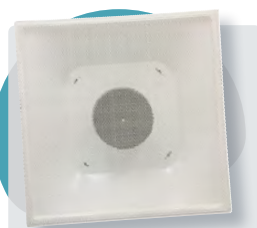
Back

Next in the pipeline

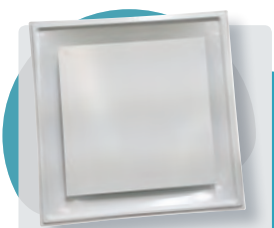
|New Aluminum Products



ADF3
Aluminum
3-Cone Diffuser



APRM
Aluminum
Perforated Returns



AISO
Aluminum
Plaque Diffuser

|Aluminum Spiral Duct Grilles



Nice Feature!

Fins follow the curve on front deflection.



GDA18
Single deflection



GDA28
Double deflection

Commercial Air Distribution Products

Unique level of service, personalized and very helpful

Great standard lead times and premium services

High quality products with exclusive features



www.airvector-hvac.com

Contact and update

Update

Updated Data Sheets and Submittals are available in PDF on our website at:

www.airvector-hvac.com

- Print them to update your catalog
- Email them to your customers

For Technical Questions

Email:

info@airvector-hvac.com

Phone:

1-866-AIRVECTOR ext 203
or
1-866-247-8328 ext 203

Fax

1-877-439-0671

Order Desk and Customer Service

Email:

order@airvector-hvac.com

Phone:

1-866-AIRVECTOR ext 201
or
11-866-247-8328 ext 201

Fax

1-877-439-0671



345 Montee-de-Liesse
Saint-Laurent, QC, H4T 1P5
Canada
Phone : 1-866-247-8328 (1-866-AIRVECTOR)
Fax : 1-877-439-0671

Submittal Drawings & Performance Data

Submittal Sheet	4	DA3	49	GADA / GADS	98	PRN	147
ADA3	4	DA4	50	GADF	99	PRT	148
ADA4	5	DCG	51	GCB10 / GCB17	100	PRTL	149
ADF3	6	DCR	52	GCB20 / GCB27	101	PSI	150
ADF3D	7	DF3	53	GCB30 / GCB37	102	PSIL	151
ADF3I	8	DF3D	54	GCB40 / GCB47	103	PSM	152
ADF4	9	DF3I	55	GDA10 / GDA17 / GDA18	104	PSML	153
ADF4D	10	DF4	56	GDA20/GDA27/GDA28	105	PST	154
ADF4I	11	DF4D	57	GDS10 / GDS17 / GDS18	106	PSTL	155
AISO	12	DF4I	58	GDS20 / GDS27 / GDS28	107	RAF / RAF7	156
AISOD	13	DLA / DLA9	59	GRT / GRT7	108	REAL / REAL7	157
AISOI	14	DLA-HI / DLA9-HI	60	GRTS - GRTA	109		
ALB ALS-SPECIAL SHAPE	15	DLAI	61	GSA10 - GAA10	110		
ALB10 / ALB17	16	DLAM	62	GSA20 - GAA20	111		
ALB20 / ALB27	17	DLAM-HI	63	GSA40 - GAA40	112		
ALB30 / ALB37	18	DRV	64	HI (option)	113		
ALB40 / ALB47	19	DSW	65	ICG	114		
ALB50 / ALB57	20	DSWD	66	ISA / ISA9	115		
ALB60 / ALB67	21	DSWI	67	ISAI	116		
ALB70 / ALB77	22	ERE / ERE7	68	ISAM	117		
ALB80 / ALB87	23	ERE1 / ERE17	69	ISO	118		
ALB90 / ALB97	24	ERE3 / ERE37	70	ISOD	119		
ALBCO	25	ERE5 / ERE57	71	ISOI	120		
ALF10 / ALF17 / ALF18	26	ERI	72	LRIF	121		
ALF1APL...	27	ERI5	73	LRMF	122		
ALF1PL...	28	ERIF	74	LRTF	123		
ALF20 / ALF27 / ALF28	29	ERIF5	75	N4	124		
ALF2APL...	30	ERM	76	N5	125		
ALF2PL	31	ERM5	77	N7	126		
ALS10 / ALS17	32	ERMF	78	N9	127		
ALS1APL	33	ERMF5	79	NBD	128		
ALS10/ALS17-L-SHAPE LIN- EAR SLOT DIFFUSER	34	ERN	80	NBI	129		
ALS10/ALS17-L-SHAPE LIN- EAR	35	ERN1 / ERN3 / ERN5	81	NEG	130		
ALS1PL	36	ERN-P	82	NES	131		
ALS1SPL	37	ERT / ERT7	83	NR6MFG	132		
ALS20 / ALS27	38	ERT1 / ERT17	84	NSA1	133		
ALS2APL	39	ERT3 / ERT37	85	NT Accessory	134		
ALS2PL	40	ERT5 / ERT57	86	NTRR	135		
ALS30 / ALS37	41	ERTF	87	NTSR	136		
ALS3APL	42	ERTF5	88	NTSS	137		
ALS3PL	43	ERU / ERU7	89	PADO	138		
ALSD1	44	ERU1 / ERU17	90	PADS	139		
ALSMC1	45	ERU3 / ERU37	91	PF	140		
ALSMC2	46	ERU5 / ERU57	92	PRE / PRE7	141		
ALSMC3	47	FERE	93	PRI	142		
ARCH / ARCH7	48	FERE5	94	PRIF	143		
		FGAA	95	PRM	144		
		FlexRight	96	PRMF	145		
		FPRE	97	PRMFL	146		

Submittal Drawings & Performance Data

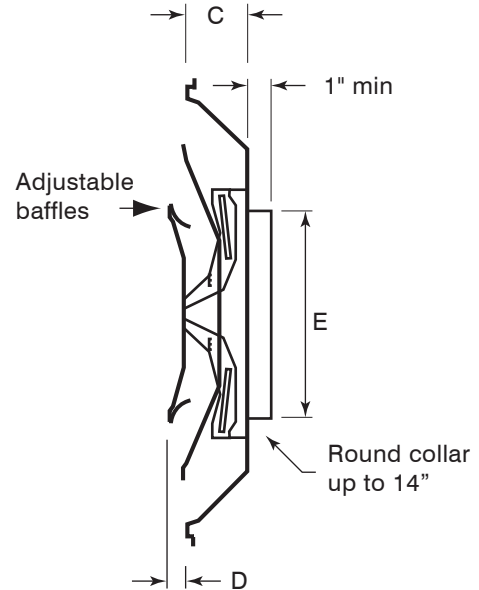
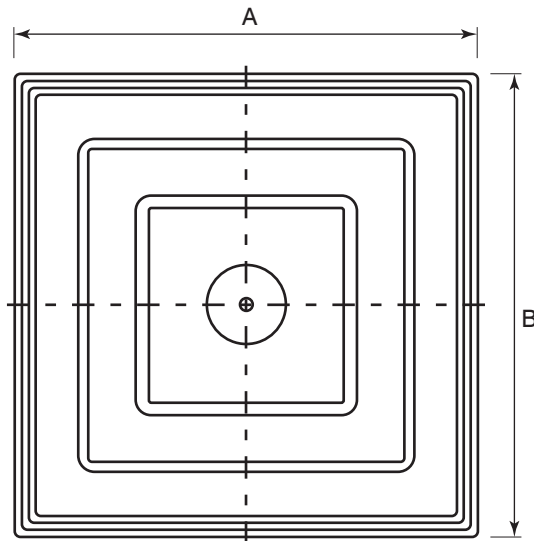
Data Sheet	159
ADF3, ADF3D, ADF3I	159
ALB Series	161
ALF Series	167
ALS Series	170
ARCH Series	181
AVS Series	185
DCG Series	186
DF3 Series	190
DF4 Series	192
DLA Series	194
DLA-HI Series	200
DLA-HI 4W	201
DRV Series	202
DSW, DSWI	203
ERx Series	205
ERx Series	207
ERxF Series	208
FGSA/FGAA Series	209
FGSA/FGAA Series	210
GCB Series	211
GDA Series	213
GRT Series	218
GSA, GAA Series	219
ISA Series	226
ISO Series	230
LRMF, LRIF, LRTF	232
PRMF, PRIF, PRTF	233
PSI, PSIL, PRI	234
PSM, PSML, PRM	236
PST Series	238
Warranty	
239	
Large Grilles in Multiple Sections	240
Sidewall Grilles Screw Holes Chart	241
Linear Grilles and Diffusers Screw Holes Chart	242
Finishes	243

Aluminum Ceiling Supply Air Diffuser 3 Cone Adjustable

- Material:** Stamped heavy gauge aluminum.
- Finish:** Powder paint coating - white.
- Air Pattern:** Adjustable air pattern from horizontal for cooling to vertical for heating, full face.
- Mounting:** Surface or lay-in T-bar ceiling.
- Core Removal:** Unlock hanger brackets by swiveling lever down. Holding cone L at opposite sides, push upwards, then turn clockwise and drop core free from back plenum.



ADA3
(All Aluminum)



Optional fiberglass insulation on back panel, complies with A.S.T.M. E84 flame and smoke test. (Available only on models with 24" x 24" face)

R4 R6

✓	Model #	Duct Size	Overall Face Dimension "A" x "B"	Depth Of Unit Dimension "C"	Exposed Depth Dimension "D"	Collar Diameter "E"
	ADA3 1206	6	11 3/4" x 11 3/4"	1 3/4"	7/16"	5 7/8"
	ADA3 1208	8	11 3/4" x 11 3/4"	1 3/4"	7/16"	7 7/8"
	ADA3 2406	6	23 3/4" x 23 3/4"	2 7/8"	7/8"	5 7/8"
	ADA3 2408	8	23 3/4" x 23 3/4"	2 7/8"	7/8"	7 7/8"
	ADA3 2410	10	23 3/4" x 23 3/4"	2 7/8"	7/8"	9 7/8"
	ADA3 2412	12	23 3/4" x 23 3/4"	2 7/8"	7/8"	11 7/8"
	ADA3 2414	14	23 3/4" x 23 3/4"	2 7/8"	7/8"	13 7/8"

Finish	
<input type="checkbox"/> /W White (Default)	<input type="checkbox"/> /C Custom (Please Specify)



Schedule type: _____

Job: _____

Architect: _____

Engineer: _____

Contractor: _____

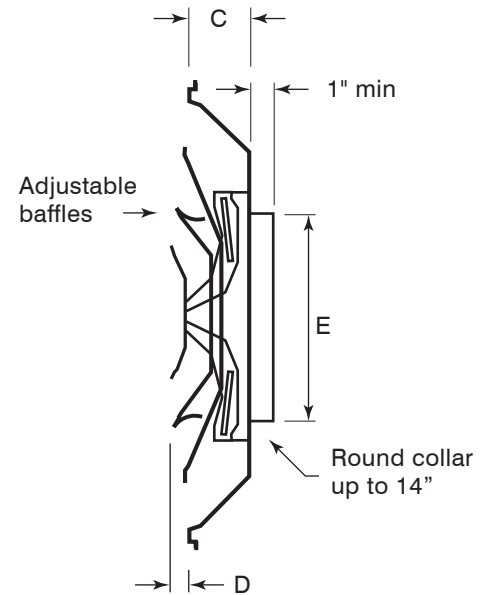
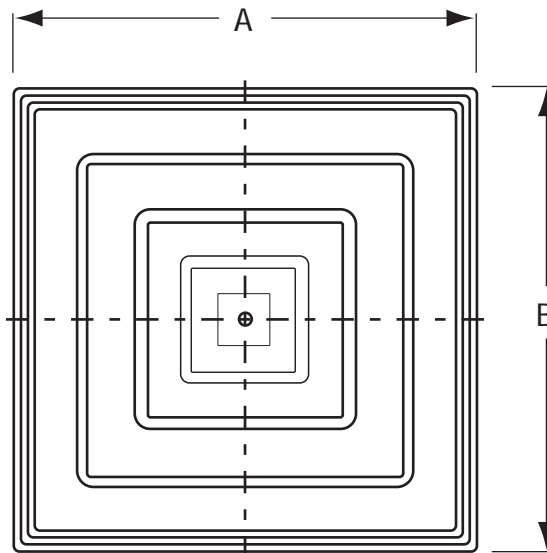
Aluminum Ceiling Supply Air Diffuser 4 Cones Adjustable

- Material:** Stamped heavy gauge aluminum.
Finish: Powder paint coating - white.
Air Pattern: Adjustable horizontal/vertical air pattern.
Mounting: Surface or lay-in T-bar ceiling.
Core Removal: Unlock hanger brackets by swiveling lever down. Holding cone L at opposite sides, push upwards, then turn clockwise and drop core free from back plenum.



ADA4
(All Aluminum)

SUBMITTAL SHEET



Optional fiberglass insulation on back panel, complies with A.S.T.M. E84 flame and smoke test. (Available only on models with 24" x 24" face)

 R4

 R6


Finish

/W White (Default)
 /C Custom (Please Specify)

✓	Model #	Duct Size	Overall Face Dimension "A" x "B"	Depth Of Unit Dimension "C"	Exposed Depth Dimension "D"	Collar Diameter "E"
	ADA4 2406	6	23 3/4" x 23 3/4"	2 7/8"	7/8"	5 7/8"
	ADA4 2408	8	23 3/4" x 23 3/4"	2 7/8"	7/8"	7 7/8"
	ADA4 2410	10	23 3/4" x 23 3/4"	2 7/8"	7/8"	9 7/8"
	ADA4 2412	12	23 3/4" x 23 3/4"	2 7/8"	7/8"	11 7/8"
	ADA4 2414	14	23 3/4" x 23 3/4"	2 7/8"	7/8"	13 7/8"

Schedule type: _____

Job: _____

Architect: _____

Engineer: _____

Contractor: _____

SUBMITTAL SHEET

Aluminum Ceiling Square Diffuser 3 Cone - Fixed air pattern

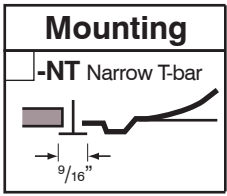
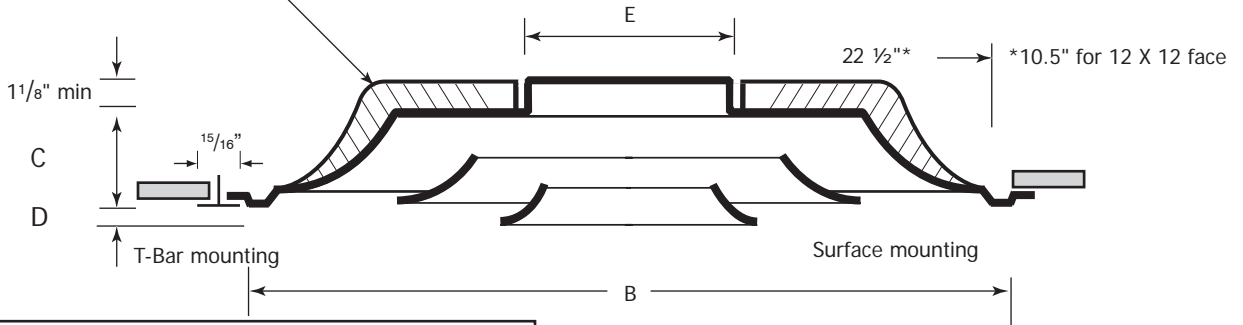
Material: Stamped heavy gauge Aluminium.
Finish: Powder paint coating - white.
Air Pattern: Fixed horizontal 360° diffusion.
Mounting: Surface or Lay-in T-bar ceiling.



ADF3
(All Aluminum)

Optional fiberglass insulation on back panel, complies with A.S.T.M. E84 flame and smoke test. (Available only on models with 24" x 24" face)

R4 R6



Round Collar Baffles

<input type="checkbox"/> W1 1 Way	<input type="checkbox"/> WC 2 Way Corner	<input type="checkbox"/> WO 2 Way Opposed	<input type="checkbox"/> W3 3 Way	<input type="checkbox"/> W4 4 Way (default)

Panel Option for T-bar lay-in Ceiling

<p>No fastening options available</p>	Steel (WxH)	Aluminum (WxH)
	<input type="checkbox"/> -X2412	<input type="checkbox"/> -Y2412
	<input type="checkbox"/> -X2424	<input type="checkbox"/> -Y2424
	<input type="checkbox"/> -X2448	<input type="checkbox"/> -Y2448
	<input type="checkbox"/> -X4824	<input type="checkbox"/> -Y4824
	<input type="checkbox"/> -X2020	<input type="checkbox"/> -Y2020

✓	Model #	Duct Size	E	Face Dim B x B	C	D
	ADF3D 1206	6	5 7/8"	11 3/4" x 11 3/4"	1 3/4"	7/16"
	ADF3D 1208	8	7 7/8"	11 3/4" x 11 3/4"	1 3/4"	7/16"
	ADF3D 2406	6	5 7/8"	23 3/4" x 23 3/4"	2 5/16"	1 3/8"
	ADF3D 2408	8	7 7/8"	23 3/4" x 23 3/4"	2 5/16"	1 3/8"
	ADF3D 2410	10	9 7/8"	23 3/4" x 23 3/4"	2 5/16"	1 3/8"
	ADF3D 2412	12	11 7/8"	23 3/4" x 23 3/4"	2 5/16"	1 3/8"
	ADF3D 2414	14	11 7/8"	23 3/4" x 23 3/4"	2 5/16"	1 3/8"

Finish

/W White (Default) /C Custom (Please Specify)



Equalizing Grid (Option)

Refer to NEG

Damper (Option)

Refer to N4	Refer to N5
Opposed Blade	Sliding Blade

Plaster Frame (Option)

Refer to PF

Schedule type: _____

Job: _____

Architect: _____

Engineer: _____

Contractor: _____

Aluminum Ceiling Square Diffuser 3 Cone - Fixed air pattern

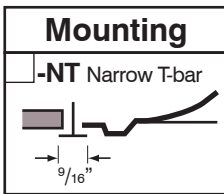
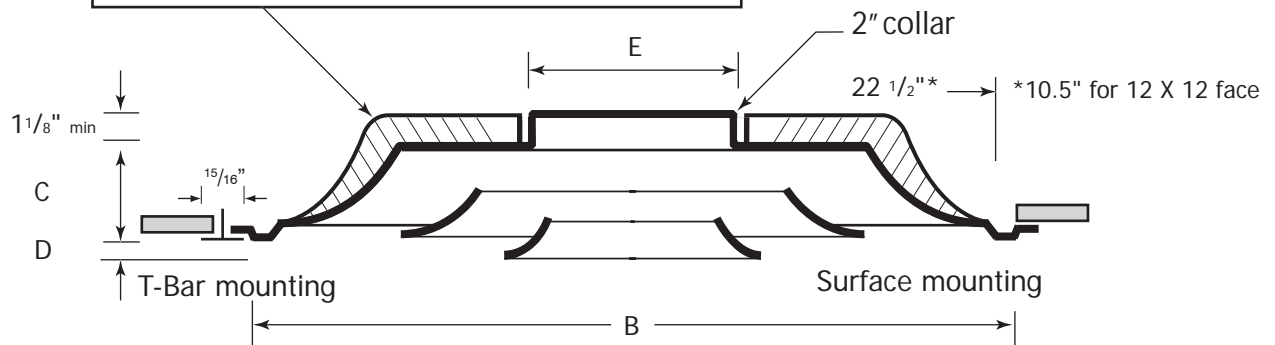
Material: Stamped heavy gauge Aluminium.
Finish: Powder paint coating - white.
Air Pattern: Fixed horizontal 360° diffusion.
Mounting: Surface or Lay-in T-bar ceiling.



ADF3D
(All Aluminum)

Optional fiberglass insulation on back panel, complies with A.S.T.M. E84 flame and smoke test. (Available only on models with 24" x 24" face)

R4 R6



Round Collar Baffles				
<input type="checkbox"/> W4 4 Way (default)	<input type="checkbox"/> W3 3 Way	<input type="checkbox"/> WO 2 Way Opposed	<input type="checkbox"/> WC 2 Way Corner	<input type="checkbox"/> W1 1 Way

Panel Option for T-bar lay-in Ceiling		
	Steel (WxH)	Alum (WxH)
	<input type="checkbox"/> -X2412	<input type="checkbox"/> -Y2412
	<input type="checkbox"/> -X2424	<input type="checkbox"/> -Y2424
	<input type="checkbox"/> -X4812	<input type="checkbox"/> -Y4812
	<input type="checkbox"/> -X4824	<input type="checkbox"/> -Y4824
No mounting options available		<input type="checkbox"/> -X2020 <input type="checkbox"/> -Y2020

✓	Model #	Duct Size	E	Face Dim B x B	C	D
	ADF3D 1206	6	5 7/8"	11 3/4" x 11 3/4"	1 3/4"	7/16"
	ADF3D 1208	8	7 7/8"	11 3/4" x 11 3/4"	1 3/4"	7/16"
	ADF3D 2406	6	5 7/8"	23 3/4" x 23 3/4"	2 5/16"	1 3/8"
	ADF3D 2408	8	7 7/8"	23 3/4" x 23 3/4"	2 5/16"	1 3/8"
	ADF3D 2410	10	9 7/8"	23 3/4" x 23 3/4"	2 5/16"	1 3/8"
	ADF3D 2412	12	11 7/8"	23 3/4" x 23 3/4"	2 5/16"	1 3/8"
	ADF3D 2414	14	11 7/8"	23 3/4" x 23 3/4"	2 5/16"	1 3/8"

Finish	
<input type="checkbox"/> /W White (Default)	<input type="checkbox"/> /C Custom (Please Specify)



Equalizing Grid Option	Damper Option		Plaster Frame Option
Refer to NEG 	Refer to N4 Opposed Blade	Refer to N5 Sliding Blade	Refer to PF

Schedule type: _____

Job: _____

Architect: _____

Engineer: _____

Contractor: _____

Aluminum Ceiling Square Diffuser 3 Cone - Fixed air pattern

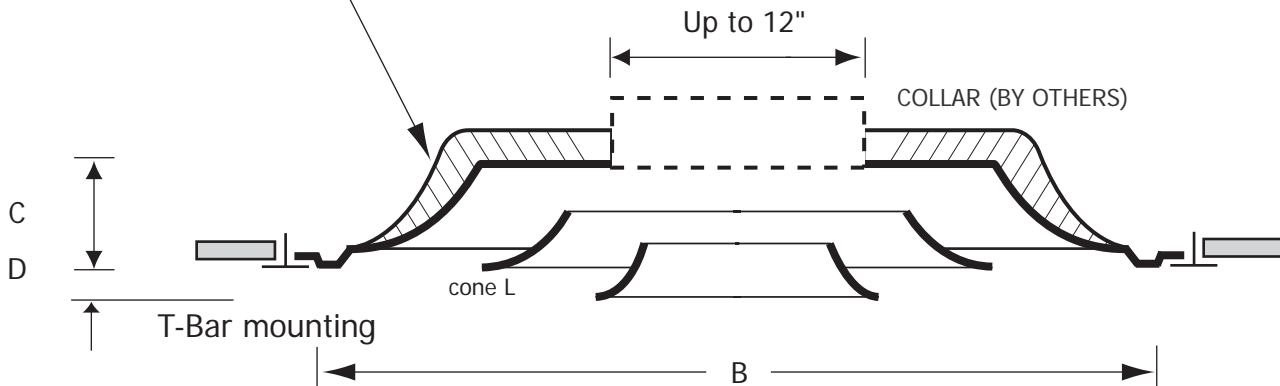
- Material:** Stamped heavy gauge aluminum.
- Finish:** Powder paint coating - white.
- Air Pattern:** Fixed horizontal 360° diffusion.
- Mounting:** Lay-in T-bar ceiling.
- Core Removal:** Unlock hanger brackets by swiveling lever down. Holding cone L at opposite sides, push upwards, then turn clockwise and drop core free from back plenum.



ADF3I
(All Aluminum)

R6 fiberglass back complies with A.S.T.M. E84 flame and smoke test.

Scored for collar sizes up to 12" D. Contractor to install job-specific collar in field. For size 14", please refer to model DF3-R6 2414.



Model #	Face Dim B x B	C	D
ADF3I	23 3/4" x 23 3/4"	2 7/8"	7/8"

Finish	
<input type="checkbox"/> /W White (Default)	<input type="checkbox"/> /C Custom (Please Specify) _____



Schedule type: _____

Job: _____

Architect: _____

Engineer: _____

Contractor: _____

Aluminum Ceiling Square Diffuser 4 Cone - Fixed air pattern

Material: Stamped heavy gauge Aluminium.
Finish: Powder paint coating - white.
Air Pattern: Fixed horizontal 360° diffusion.
Mounting: Surface or Lay-in T-bar ceiling.



ADF4
(All Aluminum)

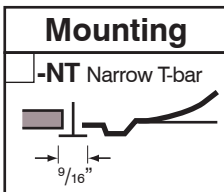
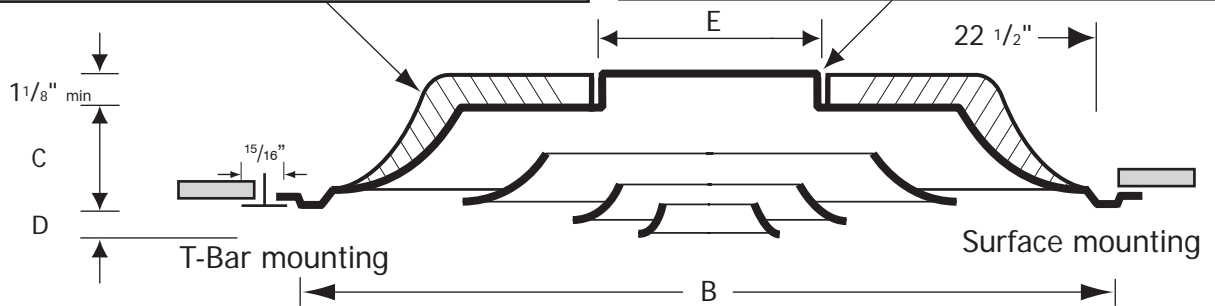
Optional fiberglass insulation on back panel, complies with A.S.T.M. E84 flame and smoke test. (Available only on models with 24" x 24" face)

R4 R6

Round collar up to 14".

Standard height is 1 1/8", 2" height available.

2" collar (specify DF4D)



Round Collar Baffles

<input type="checkbox"/> W4 4 Way (default)	<input type="checkbox"/> W3 3 Way	<input type="checkbox"/> WO 2 Way Opposed	<input type="checkbox"/> WC 2 Way Corner	<input type="checkbox"/> W1 1 Way

Panel Option for T-bar lay-in Ceiling

	Steel (WxH)	Alum (WxH)
	<input type="checkbox"/> -X2412	<input type="checkbox"/> -Y2412
	<input type="checkbox"/> -X2424	<input type="checkbox"/> -Y2424
	<input type="checkbox"/> -X4812	<input type="checkbox"/> -Y4812
	<input type="checkbox"/> -X4824	<input type="checkbox"/> -Y4824
No mounting options available		<input type="checkbox"/> -X2020 <input type="checkbox"/> -Y2020

✓	Model #	Duct Size	E	Face Dim B x B	C	D
	ADF4 2406	6	5 7/8"	23 3/4" x 23 3/4"	2 7/8"	7/8"
	ADF4 2408	8	7 7/8"	23 3/4" x 23 3/4"	2 7/8"	7/8"
	ADF4 2410	10	9 7/8"	23 3/4" x 23 3/4"	2 7/8"	7/8"
	ADF4 2412	12	11 7/8"	23 3/4" x 23 3/4"	2 7/8"	7/8"
	ADF4 2414	14	13 7/8"	23 3/4" x 23 3/4"	2 7/8"	7/8"

Finish

/W White (Default) /C Custom (Please Specify)



Equalizing Grid Option Refer to NEG 	Damper Option Refer to N4 Refer to N5 Opposed Blade Sliding Blade	Plaster Frame Option Refer to PF
---	--	--

Schedule type: _____
 Job: _____
 Architect: _____
 Engineer: _____
 Contractor: _____

SUBMITTAL SHEET

Aluminum Ceiling Square Diffuser 4 Cone - Fixed air pattern

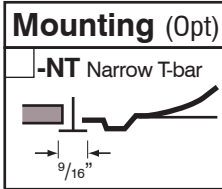
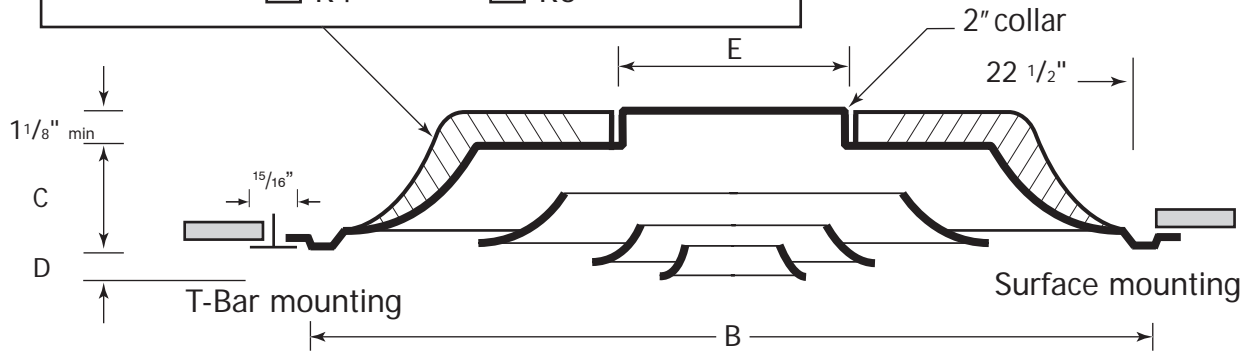
Material: Stamped heavy gauge Aluminium.
Finish: Powder paint coating - white.
Air Pattern: Fixed horizontal 360° diffusion.
Mounting: Surface or Lay-in T-bar ceiling.



ADF4D
(All Aluminum)

Optional fiberglass insulation on back panel, complies with A.S.T.M. E84 flame and smoke test. (Available only on models with 24" x 24" face)

R4 R6



Round Collar Baffles

<input type="checkbox"/> W4 4 Way (default)	<input type="checkbox"/> W3 3 Way	<input type="checkbox"/> WO 2 Way Opposed	<input type="checkbox"/> WC 2 Way Corner	<input type="checkbox"/> W1 1 Way
--	--	--	---	--

Panel Option for in T-bar lay-in Ceiling

Steel (WxH)

-X4824

-X2448

Alum (WxH)

-Y4824

-Y2448

No mounting options available

<input checked="" type="checkbox"/>	Model #	Duct Size	E	Face Dim B x B	C	D
	ADF4 2406	6	5 7/8"	23 3/4" x 23 3/4"	2 7/8"	7/8"
	ADF4 2408	8	7 7/8"	23 3/4" x 23 3/4"	2 7/8"	7/8"
	ADF4 2410	10	9 7/8"	23 3/4" x 23 3/4"	2 7/8"	7/8"
	ADF4 2412	12	11 7/8"	23 3/4" x 23 3/4"	2 7/8"	7/8"
	ADF4 2414	14	13 7/8"	23 3/4" x 23 3/4"	2 7/8"	7/8"

Finish

/W White (Default) /C Custom (Please Specify)



<p>Equalizing Grid Option</p> <p>Refer to NEG</p>	<p>Damper Option</p> <p>Refer to N4</p> <p>Opposed Blade</p> <p>Refer to N5</p> <p>Sliding Blade</p>	<p>Plaster Frame Option</p> <p>Refer to PF</p>
--	---	---

Schedule type: _____

Job: _____

Architect: _____

Engineer: _____

Contractor: _____

Aluminum Ceiling Square Diffuser 4 Cone - Fixed air pattern

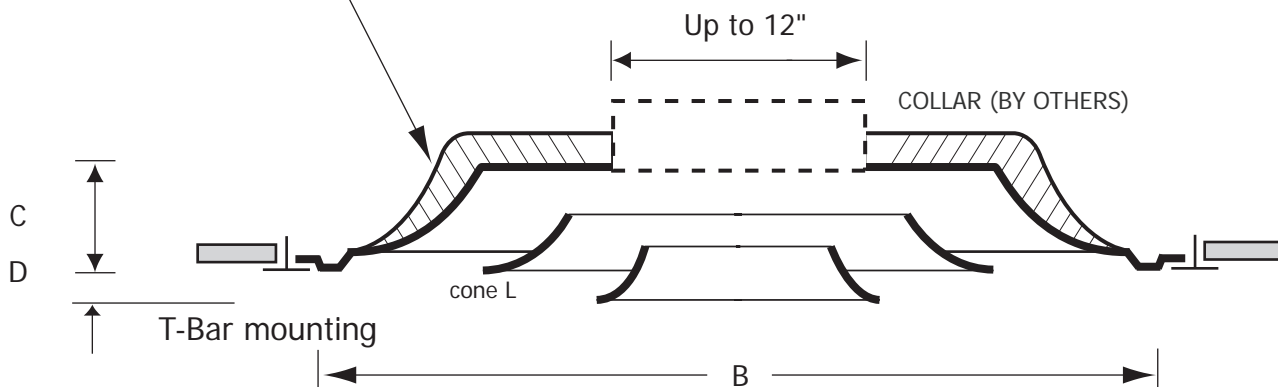
- Material:** Stamped heavy gauge Aluminium.
- Finish:** Powder paint coating - white.
- Air Pattern:** Fixed horizontal 360° diffusion.
- Mounting:** Lay-in T-bar ceiling.
- Core Removal:** Unlock hanger brackets by swiveling lever down. Holding cone L at opposite sides, push upwards, then turn clockwise and drop core free from back plenum.



ADF4I
(All Aluminum)

R6 fiberglass back complies with A.S.T.M. E84 flame and smoke test.

Scored for collar sizes up to 12" D. Contractor to install job-specific collar in field. For size 14", please refer to model DF3-R6 2414.



Model #	Face Dim B x B	C	D
ADF4I	23 3/4" x 23 3/4"	2 7/8"	7/8"

Finish	
<input type="checkbox"/> /W White (Default)	<input type="checkbox"/> /C Custom (Please Specify)



Schedule type: _____

Job: _____

Architect: _____

Engineer: _____

Contractor: _____

Square Plaque Aluminum Diffuser Architectural Line

- Material:** Stamped heavy gauge aluminum.
- Finish:** Powder paint coating - white.
- Mounting:** Surface or Lay-in T-bar ceiling.
- Air Pattern:** Fixed horizontal 360° diffusion.
- Core Removal:** Unlock hanger brackets by swiveling lever down. Holding core panel at opposite sides, push upwards, then turn clockwise and drop core free from back plenum.

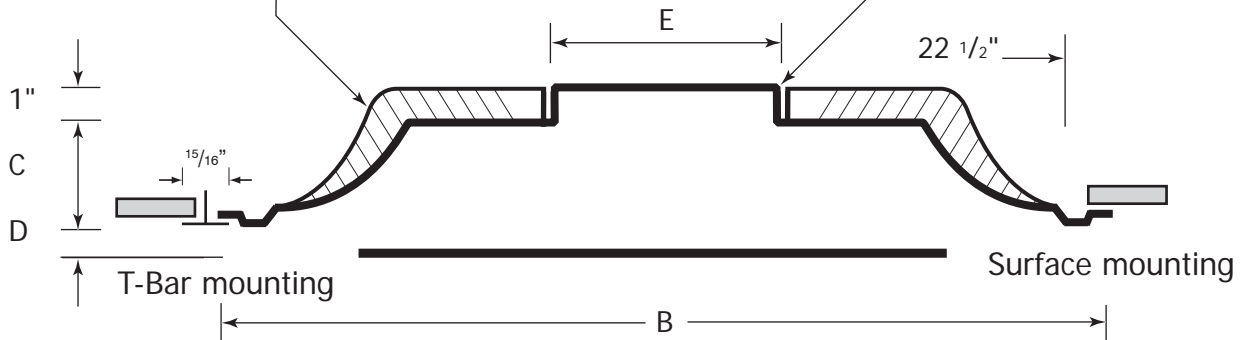


AISO
(Aluminum)

Optional R6 fiberglass insulation on back panel complies with A.S.T.M. E84 flame and smoke test. (Available only on models with 24" x 24" face)

- R4 R6

Drawn collar up to 14"D.



Round Collar Baffles				
<input type="checkbox"/> W1 1 Way	<input type="checkbox"/> WC 2 Way Corner	<input type="checkbox"/> WO 2 Way Opposed	<input type="checkbox"/> W3 3 Way	<input type="checkbox"/> W4 4 Way (default)

✓	Model #	Duct Size	E	Face Dim B x B	C	D
	AISO 1206	6	5 7/8"	11 3/4" x 11 3/4"	1 3/4"	7/16"
	AISO 1208	8	7 7/8"	11 3/4" x 11 3/4"	1 3/4"	7/16"
	AISO 2406	6	5 7/8"	23 3/4" x 23 3/4"	2 7/8"	7/8"
	AISO 2408	8	7 7/8"	23 3/4" x 23 3/4"	2 7/8"	7/8"
	AISO 2410	10	9 7/8"	23 3/4" x 23 3/4"	2 7/8"	7/8"
	AISO 2412	12	11 7/8"	23 3/4" x 23 3/4"	2 7/8"	7/8"
	AISO 2414	14	13 7/8"	23 3/4" x 23 3/4"	2 7/8"	7/8"

Mounting (Opt)

-NT Narrow T-bar

Finish

/W White (Default) /C Custom (Please Specify)



Schedule type: _____

Job: _____

Architect: _____

Engineer: _____

Contractor: _____

Square Plaque Aluminum Diffuser Architectural Line

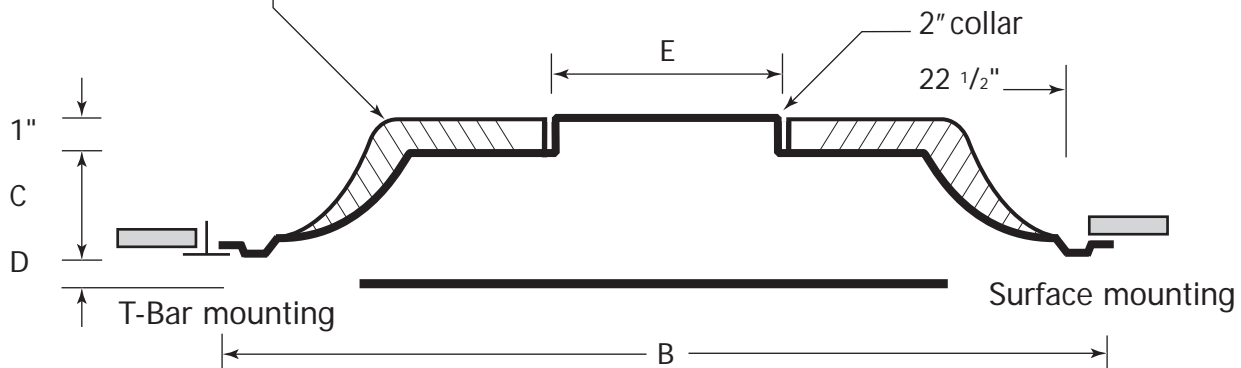
- Material:** Stamped heavy gauge aluminum.
- Finish:** Powder paint coating - white.
- Mounting:** Surface or Lay-in T-bar ceiling.
- Air Pattern:** Fixed horizontal 360° diffusion.
- Core Removal:** Unlock hanger brackets by swiveling lever down. Holding core panel at opposite sides, push upwards, then turn clockwise and drop core free from back plenum.



AISOD
(Aluminum)

Optional R6 fiberglass insulation on back panel complies with A.S.T.M. E84 flame and smoke test. (Available only on models with 24" x 24" face)

- R4 R6



Round Collar Baffles				
<input type="checkbox"/> W1 1 Way	<input type="checkbox"/> WC 2 Way Corner	<input type="checkbox"/> WO 2 Way Opposed	<input type="checkbox"/> W3 3 Way	<input type="checkbox"/> W4 4 Way (default)

✓	Model #	Duct Size	E	Face Dim B x B	C	D
	AISOD 1206	6	5 7/8"	11 3/4" x 11 3/4"	1 3/4"	7/16"
	AISOD 1208	8	7 7/8"	11 3/4" x 11 3/4"	1 3/4"	7/16"
	AISOD 2406	6	5 7/8"	23 3/4" x 23 3/4"	2 7/8"	7/8"
	AISOD 2408	8	7 7/8"	23 3/4" x 23 3/4"	2 7/8"	7/8"
	AISOD 2410	10	9 7/8"	23 3/4" x 23 3/4"	2 7/8"	7/8"
	AISOD 2412	12	11 7/8"	23 3/4" x 23 3/4"	2 7/8"	7/8"
	AISOD 2414	14	13 7/8"	23 3/4" x 23 3/4"	2 7/8"	7/8"

Finish	
<input type="checkbox"/> /W White (Default)	<input type="checkbox"/> /C Custom (Please Specify)



Schedule type: _____

Job: _____

Architect: _____

Engineer: _____

Contractor: _____

Square Plaque Aluminum Diffuser Architectural Line

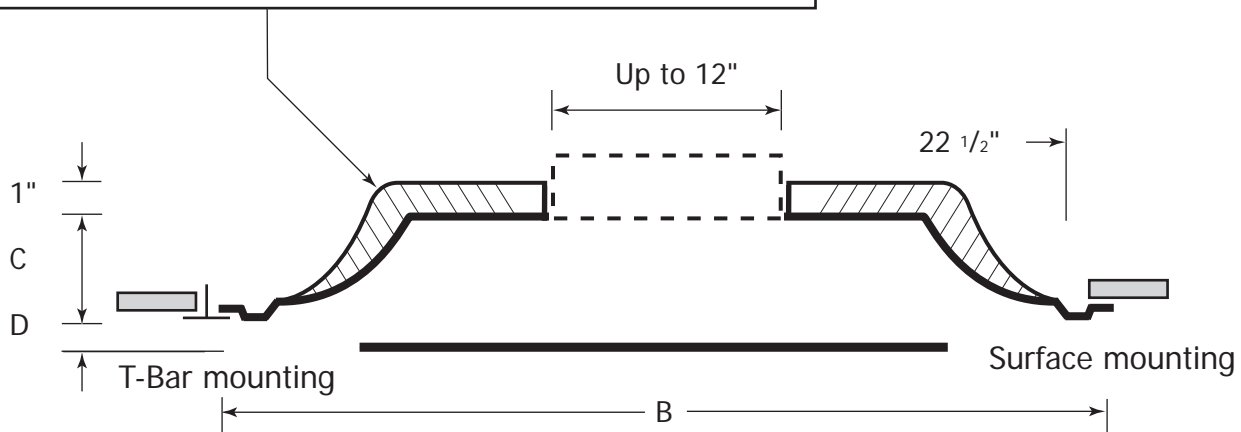
- Material:** Stamped heavy gauge aluminum.
- Finish:** Powder paint coating - white.
- Mounting:** Surface or Lay-in T-bar ceiling.
- Air Pattern:** Fixed horizontal 360° diffusion.
- Core Removal:** Unlock hanger brackets by swiveling lever down. Holding core panel at opposite sides, push upwards, then turn clockwise and drop core free from back plenum.



AISOI
(Aluminum)

R6 fiberglass back complies with A.S.T.M. E84 flame and smoke test.

Scored for collar sizes up to 12" D. Contractor to install job-specific collar in field. For size 14", please refer to model DF3-R6 2414.



Model #	Face Dim B x B	C	D
AIS03I	23 3/4" x 23 3/4"	2 7/8"	7/8"

Finish	
<input type="checkbox"/> /W White (Default)	<input type="checkbox"/> /C Custom (Please Specify) _____



Schedule type: _____

Job: _____

Architect: _____

Engineer: _____

Contractor: _____

For Special Shapes of ALB or ALS products

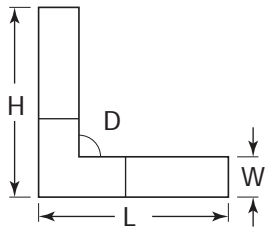
Important:

Attach with the regular ALB or ALS submittal drawing.
All dimensions are "WIDTH INCLUDED".
For ALB4 & ALB5 please indicate air flow direction with arrows on drawing.

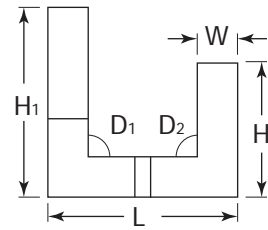
Dimension Type
 -LS (default)
List Size (1/4" more than neck size)

 -FS
Face Size

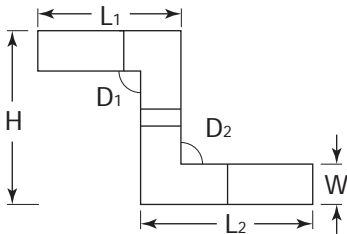
 -NS
Exact Neck Size

 L-Shape


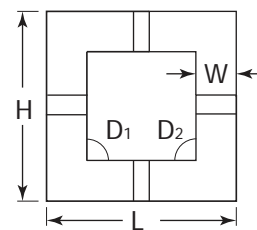
Dims	Qty	
H (in inches)	_____ "	_____ "
L (in inches)	_____ "	_____ "
W (in inches)	_____ "	_____ "
D (in degrees)	_____ °	_____ °

 U-Shape


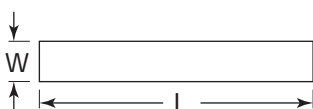
Dims	Qty	
H1 (in inches)	_____ "	_____ "
H2 (in inches)	_____ "	_____ "
L (in inches)	_____ "	_____ "
W (in inches)	_____ "	_____ "
D1 (in degrees)	_____ °	_____ °
D2 (in degrees)	_____ °	_____ °

 Z-Shape


Dims	Qty	
L1 (in inches)	_____ "	_____ "
L2 (in inches)	_____ "	_____ "
H (in inches)	_____ "	_____ "
W (in inches)	_____ "	_____ "
D1 (in degrees)	_____ °	_____ °
D2 (in degrees)	_____ °	_____ °

 O-Shape


Dims	Qty	
H (in inches)	_____ "	_____ "
L (in inches)	_____ "	_____ "
W (in inches)	_____ "	_____ "
D1 (in degrees)	_____ °	_____ °
D2 (in degrees)	_____ °	_____ °

 I-Shape (Straight)


Dims	Qty	
L (in inches)	_____ "	_____ "
W (in inches)	_____ "	_____ "

 Any Shape

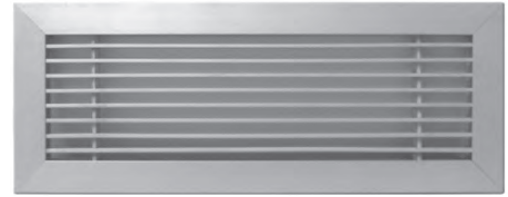
Dims	Qty	
_____ "	_____ "	_____ "
_____ "	_____ "	_____ "
_____ "	_____ "	_____ "
_____ "	_____ "	_____ "
_____ "	_____ "	_____ "
_____ "	_____ "	_____ "
_____ °	_____ °	_____ °
_____ °	_____ °	_____ °

Please submit sketch using dimensional examples above.

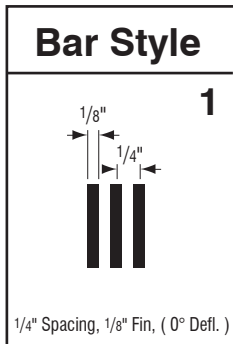
ALB Architectural Linear Bar Grille

Material: Extruded aluminum
Lengths over 72 inches supplied as multiple sections

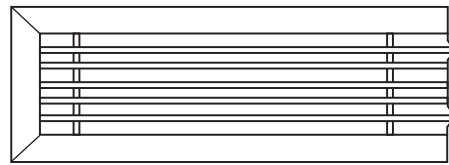
Opposed Blade Damper (optional):
Galvanized steel construction
Key-operated through grille face



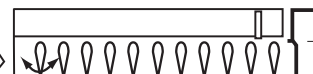
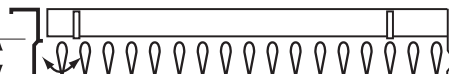
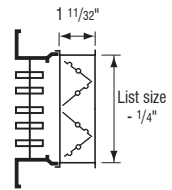
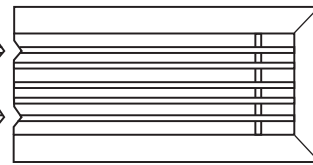
ALB10 / ALB17



ALB10 = Grille Only



ALB17 = Grille + OBD
(Min Width 3")



ALB10-L = Grille + Air Equalizing Deflector
(Min Width 4")

ALB17-L = Grille + OBD + Air Equalizing Deflector
(Min Width 4")

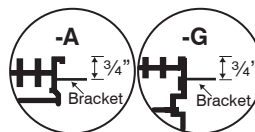
Margin Style			
<p>-A</p> <p>Listed + 9/32"</p> <p>9/16"</p> <p>Listed - 1/4"</p> <p>N/A with -3, -5, -RM, -SB</p>	<p>-B</p> <p>Listed + 7/8"</p> <p>7/8"</p> <p>Listed - 1/4"</p> <p>N/A with -5, -SB, -RM</p>	<p>-E</p> <p>Listed + 1 1/4"</p> <p>1 1/16"</p> <p>Listed - 1/4"</p> <p>N/A with -5, -SB, -RM</p>	<p>-F</p> <p>Listed + 1 3/8"</p> <p>1"</p> <p>Listed - 1/4"</p> <p>ONLY with -1, -3, -5, -RM</p>
<p>-G</p> <p>Listed - 1/4"</p> <p>3/16"</p> <p>Listed - 1/4"</p> <p>ONLY with -1, -5, -RM, -SB</p>	<p>-R</p> <p>Listed + 1 1/4"</p> <p>1 1/16"</p> <p>Listed - 1/4"</p> <p>N/A with -5, -SB, -RM</p>	<p>-T</p> <p>Listed - 1/4"</p> <p>1 1/16"</p> <p>Listed - 1 3/4"</p> <p>N/A with -2, -3, -5, -SB, -RM</p>	<p>-P Plaster-In Frame</p> <p>Listed + 1 1/4"</p> <p>Plaster</p> <p>Gyproc</p> <p>Listed - 1/4"</p> <p>ONLY with -5, -RM</p>

Fastening Method	
<p>-1 No Fastening</p> <p>N/A with -RM and frame -P</p>	<p>-2 Spring clip</p> <p>N/A with -F, -G, -P, -T</p>
<p>-3 Screw</p> <p>N/A with -A, -G, -T</p>	<p>-4 Concealed</p> <p>N/A with -F, -G, -P Min Width 4"</p>
<p>-5 Core spring clips</p> <p>Only with combined -RM and frames -F, -G, -P</p>	

Finish					
<p>/W</p> <p>White (Default)</p>	<p>/M</p> <p>Mill Finish</p>	<p>/A</p> <p>Anodized</p>	<p>/B</p> <p>Brushed Aluminum N/A with -G, -R</p>	<p>/L</p> <p>Brushed & Lacquered N/A with -G, -R</p>	<p>/C Custom (Please Specify)</p>



- Security Ceiling Wire -CW**
- Mounting Brackets for Sheetrock -SB**
(3/4" from the face) Only w/ -A -G
- Reinforced Floor Application -RF**
(6" max width for all frames, for over 6" use -F up to 20" more)
- Removable Core Application -RM**
(For ceiling add -5, -CW ; for wall add -5)
- Frame Gasket -GK**
- Vertical Bars -V**



Up to 1/8 inch increments without damper.
Dimensions shown contain expansion tolerances based on temperature rise of 40°F above the ambient temperature at which the material is fabricated.

Schedule Type: _____

Project: _____

Architect: _____

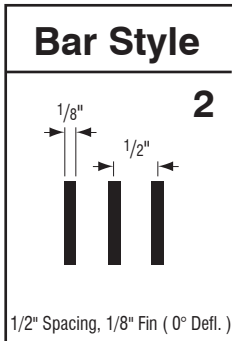
Engineer: _____

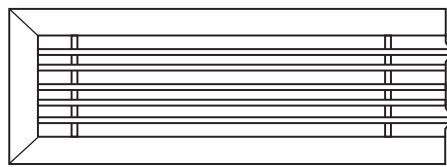
Contractor: _____

ALB Architectural Linear Bar Grille

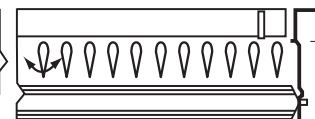
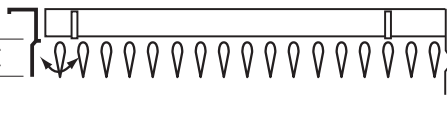
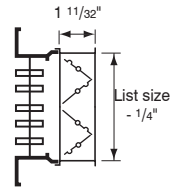
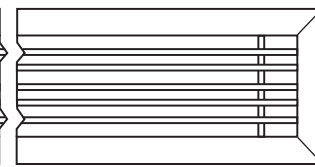
Material: Extruded aluminum
Lengths over 72 inches supplied as multiple sections

Opposed Blade Damper (optional):
Galvanized steel construction
Key-operated through grille face


ALB20 / ALB27

 ALB20 = Grille Only

 Braces set at max 11"
(with -RF max 6")

 ALB27 = Grille + OBD

(Min Width 3")


 ALB20-L = Grille + Air Equalizing Deflector
(Min Width 4")

 ALB27-L = Grille + OBD + Air Equalizing Deflector
(Min Width 4")

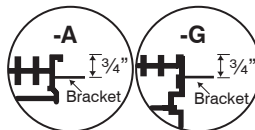
Margin Style			
<input type="checkbox"/> -A Listed + 9/32" 9/16" Listed - 1/4" N/A with -3, -5, -RM, -SB	<input type="checkbox"/> -B Listed + 7/8" 7/8" Listed - 1/4" N/A with -5, -SB, -RM	<input type="checkbox"/> -E Listed + 1 1/4" 1 1/16" Listed - 1/4" N/A with -5, -SB, -RM	<input type="checkbox"/> -F Listed + 1 3/8" 1" Listed - 1/4" ONLY with -1, -3, -5, -RM
<input type="checkbox"/> -G Listed - 1/4" 3/16" Listed - 1/4" ONLY with -1, -5, -RM, -SB	<input type="checkbox"/> -R Listed + 1 1/4" 1 1/16" Listed - 1/4" N/A with -5, -SB, -RM	<input type="checkbox"/> -T Listed - 1/4" 1 1/16" Listed - 1 3/4" N/A with -2, -3, -5, -SB, -RM	<input type="checkbox"/> -P Plaster-In Frame Listed + 1 1/4" Plaster Gyproc Listed - 1/4" ONLY with -5, -RM

Fastening Method	
<input type="checkbox"/> -1 No Fastening N/A with -RM and frame -P	<input type="checkbox"/> -2 Spring clip N/A with -F, -G, -P, -T
<input type="checkbox"/> -3 Screw N/A with -A, -G, -T	<input type="checkbox"/> -4 Concealed N/A with -F, -G, -P Min Width 4"
<input type="checkbox"/> -5 Core spring clips Only with combined -RM and frames -F, -G, -P	

Finish					
<input type="checkbox"/> /W White (Default)	<input type="checkbox"/> /M Mill Finish	<input type="checkbox"/> /A Anodized	<input type="checkbox"/> /B Brushed Aluminum N/A with -G, -R	<input type="checkbox"/> /L Brushed & Lacquered N/A with -G, -R	<input type="checkbox"/> /C Custom (Please Specify)



- Security Ceiling Wire -CW**
- Mounting Brackets for Sheetrock -SB**
(3/4" from the face) Only w/ -A -G
- Reinforced Floor Application -RF**
(6" max width recommended for high traffic, 8" max width for occasional traffic)
- Removable Core Application -RM**
Only w/ -F, -G
- Frame Gasket -GK**
- Vertical Bars -V**



Up to 1/8 inch increments without damper.
Dimensions shown contain expansion tolerances based on temperature rise of 40°F above the ambient temperature at which the material is fabricated.

Schedule Type: _____

Project: _____

Architect: _____

Engineer: _____

Contractor: _____

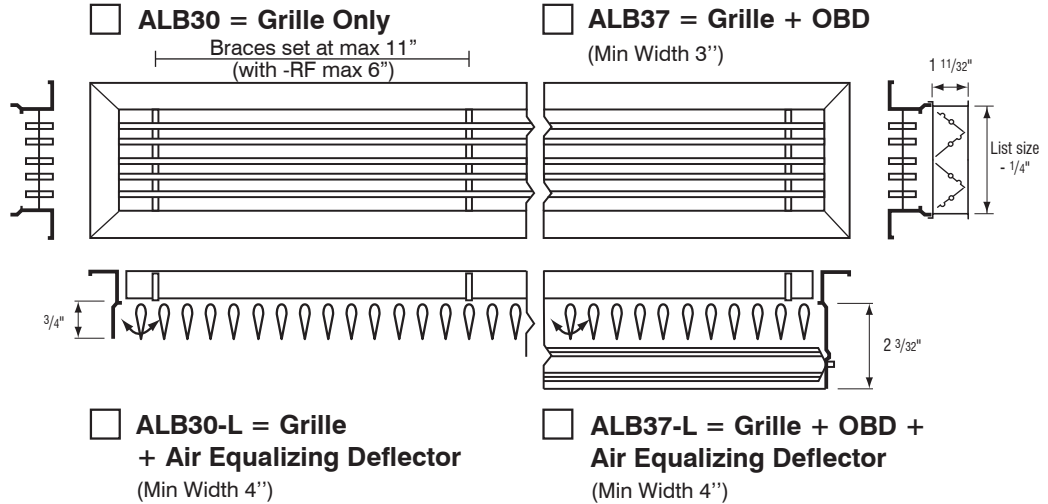
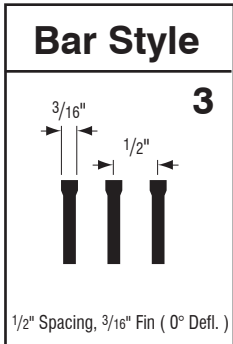
ALB Architectural Linear Bar Grille

Material: Extruded aluminum
Lengths over 72 inches supplied as multiple sections

Opposed Blade Damper (optional):
Galvanized steel construction
Key-operated through grille face



ALB30 / ALB37



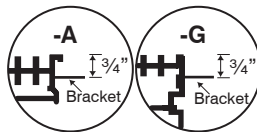
Margin Style			
<input type="checkbox"/> -A Listed + 9/32" 9/16" Listed - 1/4" N/A with -3, -5, -RM, -SB	<input type="checkbox"/> -B Listed + 7/8" 7/8" Listed - 1/4" N/A with -5, -SB, -RM	<input type="checkbox"/> -E Listed + 1 1/4" 1 1/16" Listed - 1/4" N/A with -5, -SB, -RM	<input type="checkbox"/> -F Listed + 1 3/8" 1" Listed - 1/4" ONLY with -1, -3, -5, -RM
<input type="checkbox"/> -G Listed - 1/4" 3/16" Listed - 1/4" ONLY with -1, -5, -RM, -SB	<input type="checkbox"/> -R Listed + 1 1/4" 1 1/16" Listed - 1/4" N/A with -5, -SB, -RM	<input type="checkbox"/> -T Listed - 1/4" 1 1/16" Listed - 1 3/4" N/A with -2, -3, -5, -SB, -RM	<input type="checkbox"/> -P Plaster-In Frame Listed + 1 1/4" Listed - 1/4" ONLY with -5, -RM

Fastening Method	
<input type="checkbox"/> -1 No Fastening N/A with -RM and frame -P	<input type="checkbox"/> -2 Spring clip N/A with -F, -G, -P, -T
<input type="checkbox"/> -3 Screw N/A with -A, -G, -T	<input type="checkbox"/> -4 Concealed N/A with -F, -G, -P Min Width 4"
<input type="checkbox"/> -5 Core spring clips Only with combined -RM and frames -F, -G, -P	

Finish					
<input type="checkbox"/> /W White (Default)	<input type="checkbox"/> /M Mill Finish	<input type="checkbox"/> /A Anodized	<input type="checkbox"/> /B Brushed Aluminum N/A with -G, -R	<input type="checkbox"/> /L Brushed & Lacquered N/A with -G, -R	<input type="checkbox"/> /C Custom (Please Specify)



- Security Ceiling Wire -CW**
- Mounting Brackets for Sheetrock -SB**
(3/4" from the face) Only w/ -A -G
- Reinforced Floor Application -RF**
(6" max width recommended for high traffic, 8" max width for occasional traffic)
- Removable Core Application -RM**
Only w/ -F, -G
- Frame Gasket -GK**
- Vertical Bars -V**



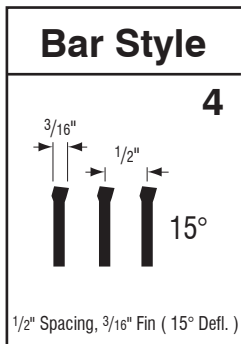
Up to 1/8 inch increments without damper.
Dimensions shown contain expansion tolerances based on temperature rise of 40°F above the ambient temperature at which the material is fabricated.

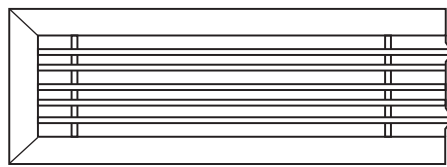
Schedule Type:	_____
Project:	_____
Architect:	_____
Engineer:	_____
Contractor:	_____

ALB Architectural Linear Bar Grille

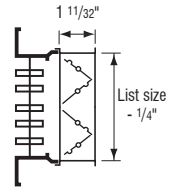
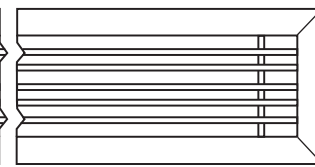
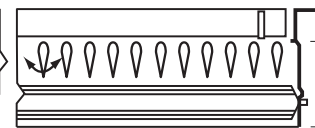
Material: Extruded aluminum
Lengths over 72 inches supplied as multiple sections

Opposed Blade Damper (optional):
Galvanized steel construction
Key-operated through grille face


ALB40 / ALB47

 ALB40 = Grille Only

 Braces set at max 11"
(with -RF max 6")

 ALB47 = Grille + OBD

(Min Width 3")


 **ALB40-L = Grille
+ Air Equalizing Deflector**
(Min Width 4")

 **ALB47-L = Grille + OBD +
Air Equalizing Grid** (Min Width 4")

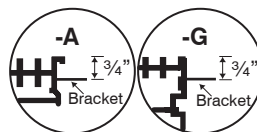
Margin Style			
<input type="checkbox"/> -A Listed + 9/32" 9/16" Listed - 1/4" N/A with -3, -5, -RM, -SB	<input type="checkbox"/> -B Listed + 7/8" 7/8" Listed - 1/4" N/A with -5, -SB, -RM	<input type="checkbox"/> -E Listed + 1 1/4" 1 1/16" Listed - 1/4" N/A with -5, -SB, -RM	<input type="checkbox"/> -F Listed + 1 3/8" 1" Listed - 1/4" ONLY with -1, -3, -5, -RM
<input type="checkbox"/> -G Listed - 1/4" 3/16" Listed - 1/4" ONLY with -1, -5, -RM, -SB	<input type="checkbox"/> -R Listed + 1 1/4" 1 1/16" Listed - 1/4" N/A with -5, -SB, -RM	<input type="checkbox"/> -T Listed - 1/4" 1 1/16" Listed - 1 3/4" N/A with -2, -3, -5, -SB, -RM	<input type="checkbox"/> -P Plaster-In Frame Listed + 1 1/4" Plaster Gyproc Listed - 1/4" ONLY with -5, -RM

Fastening Method	
<input type="checkbox"/> -1 No Fastening N/A with -RM and frame -P	<input type="checkbox"/> -2 Spring clip N/A with -F, -G, -P, -T
<input type="checkbox"/> -3 Screw N/A with -A, -G, -T	<input type="checkbox"/> -4 Concealed N/A with -F, -G, -P Min Width 4"
<input type="checkbox"/> -5 Core spring clips Only with combined -RM and frames -F, -G, -P	

Finish					
<input type="checkbox"/> /W White (Default)	<input type="checkbox"/> /M Mill Finish	<input type="checkbox"/> /A Anodized	<input type="checkbox"/> /B Brushed Aluminum N/A with -G, -R	<input type="checkbox"/> /L Brushed & Lacquered N/A with -G, -R	<input type="checkbox"/> /C Custom (Please Specify)



- Security Ceiling Wire -CW**
- Mounting Brackets for Sheetrock -SB**
(3/4" from the face) Only w/ -A -G
- Reinforced Floor Application -RF**
(6" max width recommended for high traffic, 8" max width for occasional traffic)
- Removable Core Application -RM**
Only w/ -F, -G
- Frame Gasket -GK**
- Vertical Bars -V**



Up to 1/8 inch increments without damper.
Dimensions shown contain expansion tolerances based on temperature rise of 40°F above the ambient temperature at which the material is fabricated.

Schedule Type:	_____
Project:	_____
Architect:	_____
Engineer:	_____
Contractor:	_____

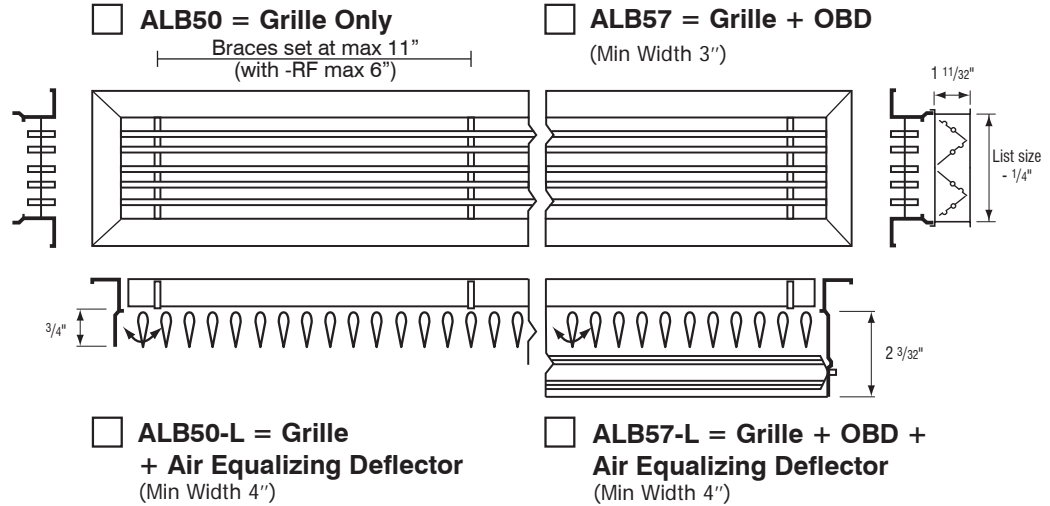
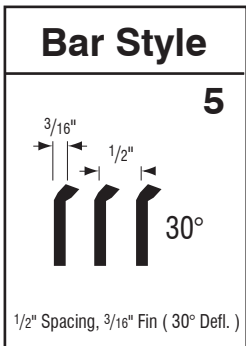
ALB Architectural Linear Bar Grille

Material: Extruded aluminum
Lengths over 72 inches supplied as multiple sections

Opposed Blade Damper (optional):
Galvanized steel construction
Key-operated through grille face



ALB50 / ALB57



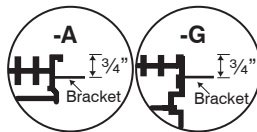
Margin Style			
<input type="checkbox"/> -A Listed + 9/32" 9/16" Listed - 1/4" N/A with -3, -5, -RM, -SB	<input type="checkbox"/> -B Listed + 7/8" 7/8" Listed - 1/4" N/A with -5, -SB, -RM	<input type="checkbox"/> -E Listed + 1 1/4" 1 1/16" Listed - 1/4" N/A with -5, -SB, -RM	<input type="checkbox"/> -F Listed + 1 3/8" 1" Listed - 1/4" ONLY with -1, -3, -5, -RM
<input type="checkbox"/> -G Listed - 1/4" 3/16" Listed - 1/4" ONLY with -1, -5, -RM, -SB	<input type="checkbox"/> -R Listed + 1 1/4" 1 1/16" Listed - 1/4" N/A with -5, -SB, -RM	<input type="checkbox"/> -T Listed - 1/4" 1 1/16" Listed - 1 3/4" N/A with -2, -3, -5, -SB, -RM	<input type="checkbox"/> -P Plaster-In Frame Listed + 1 1/4" Listed - 1/4" ONLY with -5, -RM

Fastening Method	
<input type="checkbox"/> -1 No Fastening N/A with -RM and frame -P	<input type="checkbox"/> -2 Spring clip N/A with -F, -G, -P, -T
<input type="checkbox"/> -3 Screw N/A with -A, -G, -T	<input type="checkbox"/> -4 Concealed N/A with -F, -G, -P Min Width 4"
<input type="checkbox"/> -5 Core spring clips Only with combined -RM and frames -F, -G, -P	

Finish					
<input type="checkbox"/> /W White (Default)	<input type="checkbox"/> /M Mill Finish	<input type="checkbox"/> /A Anodized	<input type="checkbox"/> /B Brushed Aluminum N/A with -G, -R	<input type="checkbox"/> /L Brushed & Lacquered N/A with -G, -R	<input type="checkbox"/> /C Custom (Please Specify)



- Security Ceiling Wire -CW**
- Mounting Brackets for Sheetrock -SB**
(3/4" from the face) Only w/ -A -G
- Reinforced Floor Application -RF**
(6" max width recommended for high traffic, 8" max width for occasional traffic)
- Removable Core Application -RM**
Only w/ -F, -G
- Frame Gasket -GK**
- Vertical Bars -V**



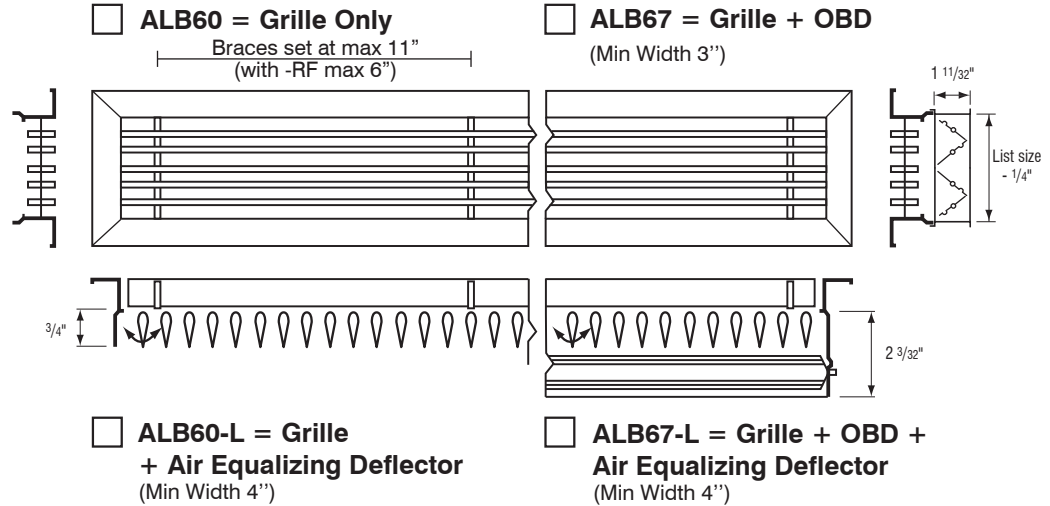
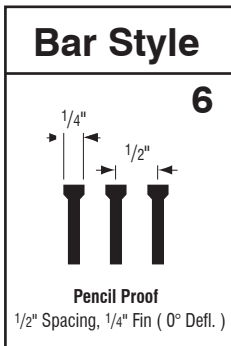
Up to 1/8 inch increments without damper.
Dimensions shown contain expansion tolerances based on temperature rise of 40°F above the ambient temperature at which the material is fabricated.

Schedule Type:	_____
Project:	_____
Architect:	_____
Engineer:	_____
Contractor:	_____

ALB Architectural Linear Bar Grille

Material: Extruded aluminum
Lengths over 72 inches supplied as multiple sections

Opposed Blade Damper (optional):
Galvanized steel construction
Key-operated through grille face


ALB60 / ALB67


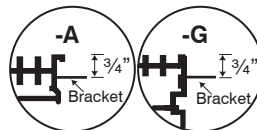
Margin Style			
<input type="checkbox"/> -A Listed + 9/32" 9/16" Listed - 1/4" N/A with -3, -5, -RM, -SB	<input type="checkbox"/> -B Listed + 7/8" 7/8" Listed - 1/4" N/A with -5, -SB, -RM	<input type="checkbox"/> -E Listed + 1 1/4" 1 1/16" Listed - 1/4" N/A with -5, -SB, -RM	<input type="checkbox"/> -F Listed + 1 3/8" 1" Listed - 1/4" ONLY with -1, -3, -5, -RM
<input type="checkbox"/> -G Listed - 1/4" 3/16" Listed - 1/4" ONLY with -1, -5, -RM, -SB	<input type="checkbox"/> -R Listed + 1 1/4" 1 1/16" Listed - 1/4" N/A with -5, -SB, -RM	<input type="checkbox"/> -T Listed - 1/4" 1 1/16" Listed - 1 3/4" N/A with -2, -3, -5, -SB, -RM	<input type="checkbox"/> -P Plaster-In Frame Listed + 1 1/4" Listed - 1/4" ONLY with -5, -RM

Fastening Method	
<input type="checkbox"/> -1 No Fastening N/A with -RM and frame -P	<input type="checkbox"/> -2 Spring clip N/A with -F, -G, -P, -T
<input type="checkbox"/> -3 Screw N/A with -A, -G, -T	<input type="checkbox"/> -4 Concealed N/A with -F, -G, -P Min Width 4"
<input type="checkbox"/> -5 Core spring clips Only with combined -RM and frames -F, -G, -P	

Finish					
<input type="checkbox"/> /W White (Default)	<input type="checkbox"/> /M Mill Finish	<input type="checkbox"/> /A Anodized	<input type="checkbox"/> /B Brushed Aluminum N/A with -G, -R	<input type="checkbox"/> /L Brushed & Lacquered N/A with -G, -R	<input type="checkbox"/> /C Custom (Please Specify)



- Security Ceiling Wire -CW**
- Mounting Brackets for Sheetrock -SB**
(3/4" from the face) Only w/ -A -G
- Reinforced Floor Application -RF**
(6" max width recommended for high traffic, 8" max width for occasional traffic)
- Removable Core Application -RM**
Only w/ -F, -G
- Frame Gasket -GK**
- Vertical Bars -V**



Up to 1/8 inch increments without damper.
Dimensions shown contain expansion tolerances based on temperature rise of 40°F above the ambient temperature at which the material is fabricated.

Schedule Type:	_____
Project:	_____
Architect:	_____
Engineer:	_____
Contractor:	_____

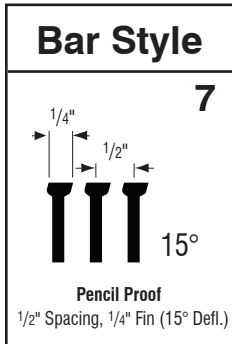
ALB Architectural Linear Bar Grille

Material: Extruded aluminum
Lengths over 72 inches supplied as multiple sections

Opposed Blade Damper (optional):
Galvanized steel construction
Key-operated through grille face

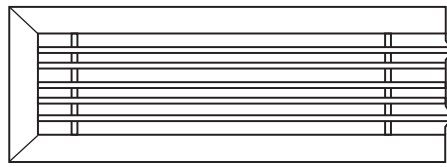


ALB70 / ALB77



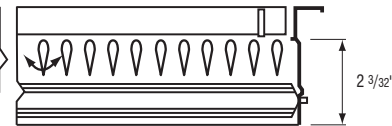
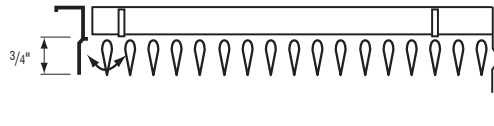
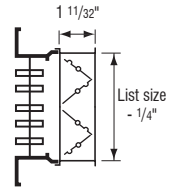
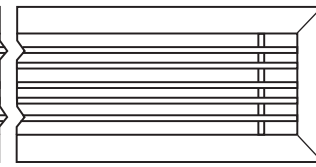
ALB70 = Grille Only

Braces set at max 11"
(with -RF max 6")



ALB77 = Grille + OBD

(Min Width 3")



ALB70-L = Grille + Air Equalizing Deflector
(Min Width 4")

ALB77-L = Grille + OBD + Air Equalizing Deflector
(Min Width 4")

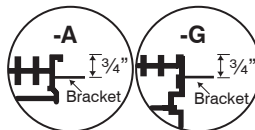
Margin Style			
<input type="checkbox"/> -A Listed + 9/32" 9/16" Listed - 1/4" N/A with -3, -5, -RM, -SB	<input type="checkbox"/> -B Listed + 7/8" 7/8" Listed - 1/4" N/A with -5, -SB, -RM	<input type="checkbox"/> -E Listed + 1 1/4" 1 1/16" Listed - 1/4" N/A with -5, -SB, -RM	<input type="checkbox"/> -F Listed + 1 3/8" 1" Listed - 1/4" ONLY with -1, -3, -5, -RM
<input type="checkbox"/> -G Listed - 1/4" 3/16" Listed - 1/4" ONLY with -1, -5, -RM, -SB	<input type="checkbox"/> -R Listed + 1 1/4" 1 1/16" Listed - 1/4" N/A with -5, -SB, -RM	<input type="checkbox"/> -T Listed - 1/4" 1 1/16" Listed - 1 3/4" N/A with -2, -3, -5, -SB, -RM	<input type="checkbox"/> -P Plaster-In Frame Listed + 1 1/4" Listed - 1/4" ONLY with -5, -RM

Fastening Method	
<input type="checkbox"/> -1 No Fastening N/A with -RM and frame -P	<input type="checkbox"/> -2 Spring clip N/A with -F, -G, -P, -T
<input type="checkbox"/> -3 Screw N/A with -A, -G, -T	<input type="checkbox"/> -4 Concealed N/A with -F, -G, -P Min Width 4"
<input type="checkbox"/> -5 Core spring clips Only with combined -RM and frames -F, -G, -P	

Finish					
<input type="checkbox"/> /W White (Default)	<input type="checkbox"/> /M Mill Finish	<input type="checkbox"/> /A Anodized	<input type="checkbox"/> /B Brushed Aluminum N/A with -G, -R	<input type="checkbox"/> /L Brushed & Lacquered N/A with -G, -R	<input type="checkbox"/> /C Custom (Please Specify)



- Security Ceiling Wire -CW**
- Mounting Brackets for Sheetrock -SB**
(3/4" from the face) Only w/ -A -G
- Reinforced Floor Application -RF**
(6" max width recommended for high traffic, 8" max width for occasional traffic)
- Removable Core Application -RM**
Only w/ -F, -G
- Frame Gasket -GK**
- Vertical Bars -V**



Up to 1/8 inch increments without damper.
Dimensions shown contain expansion tolerances based on temperature rise of 40°F above the ambient temperature at which the material is fabricated.

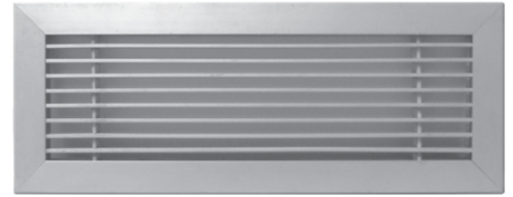
Schedule Type:	_____
Project:	_____
Architect:	_____
Engineer:	_____
Contractor:	_____

ALB80 Heavy-duty Deflected Bar Grille

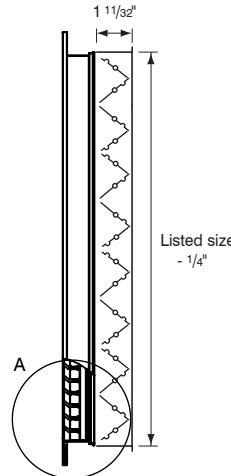
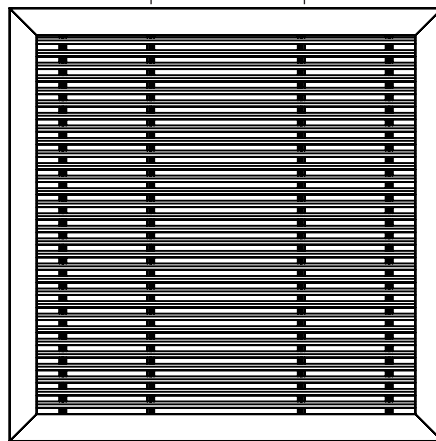
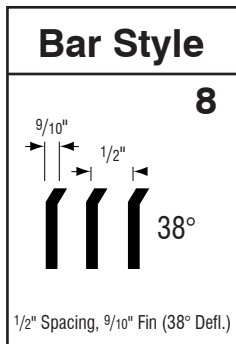
Material: Extruded aluminum
Lengths over 72 inches supplied as multiple sections

Opposed Blade Damper (optional):
Galvanized steel construction
Key-operated through grille face

Braces set at max 11"
(with -RF max 6")



ALB80 / ALB87



- ALB80 = Grille Only**
- ALB87 = Grille + OBD**
(Min Width 3")
- ALB80-L = Grille + Air Equalizing Deflector**
(Min Width 4")
- ALB87-L = Grille + OBD + Air Equalizing Deflector**
(Min Width 4")

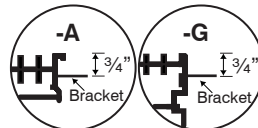
Margin Style			
<p>-A</p> <p>Listed + 9/32"</p> <p>9/16"</p> <p>Listed - 1/4"</p> <p>N/A with -3, -5, -RM, -SB</p>	<p>-B</p> <p>Listed + 7/8"</p> <p>7/8"</p> <p>Listed - 1/4"</p> <p>N/A with -5, -SB, -RM</p>	<p>-E</p> <p>Listed + 1 1/4"</p> <p>1 1/16"</p> <p>Listed - 1/4"</p> <p>N/A with -5, -SB, -RM</p>	<p>-F</p> <p>Listed + 1 3/8"</p> <p>1"</p> <p>Listed - 1/4"</p> <p>ONLY with -1, -3, -5, -RM</p>
<p>-G</p> <p>Listed - 1/4"</p> <p>3/16"</p> <p>Listed - 1/4"</p> <p>ONLY with -1, -5, -RM, -SB</p>	<p>-R</p> <p>Listed + 1 1/4"</p> <p>1 1/16"</p> <p>Listed - 1/4"</p> <p>N/A with -5, -SB, -RM</p>	<p>-T</p> <p>Listed - 1/4"</p> <p>1 1/16"</p> <p>Listed - 1 3/4"</p> <p>N/A with -2, -3, -5, -SB, -RM</p>	<p>-P Plaster-In Frame</p> <p>Listed + 1 1/4"</p> <p>Listed - 1/4"</p> <p>ONLY with -5, -RM</p>

Fastening Method	
<p>-1 No Fastening</p> <p>N/A with -RM and frame -P</p>	<p>-2 Spring clip</p> <p>N/A with -F, -G, -P, -T</p>
<p>-3 Screw</p> <p>N/A with -A, -G, -T</p>	<p>-4 Concealed</p> <p>N/A with -F, -G, -P Min Width 4"</p>
<p>-5 Core spring clips</p> <p>Only with combined -RM and frames -F, -G, -P</p>	

Finish					
<p>/W</p> <p>White (Default)</p>	<p>/M</p> <p>Mill Finish</p>	<p>/A</p> <p>Anodized</p>	<p>/B</p> <p>Brushed Aluminum N/A with -G, -R</p>	<p>/L</p> <p>Brushed & Lacquered N/A with -G, -R</p>	<p>/C Custom (Please Specify)</p>



- Security Ceiling Wire -CW**
- Mounting Brackets for Sheetrock -SB**
(3/4" from the face) Only w/ -A -G
- Reinforced Floor Application -RF**
(6" max width recommended for high traffic, 8" max width for occasional traffic)
- Removable Core Application -RM**
Only w/ -F, -G
- Frame Gasket -GK**
- Vertical Bars -V**
- Debris Screen or Bird Screen (1/2" x 1/2" Mesh) -DS**
- Insect Screen -IS**



Up to 1/8 inch increments without damper.

Dimensions shown contain expansion tolerances based on temperature rise of 40°F above the ambient temperature at which the material is fabricated.

Schedule Type: _____

Project: _____

Architect: _____

Engineer: _____

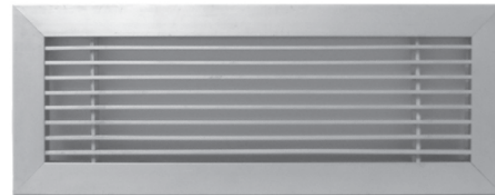
Contractor: _____

ALB80 Heavy-duty Deflected Bar Grille

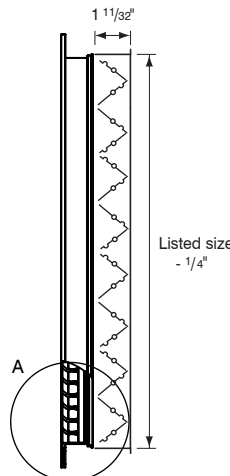
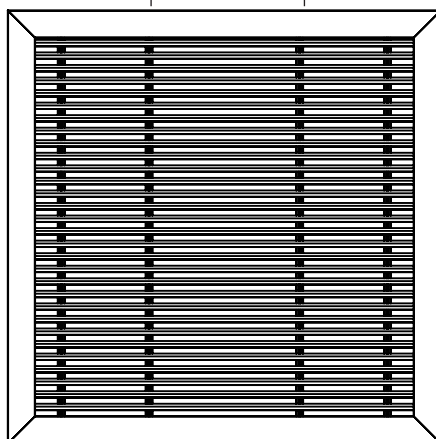
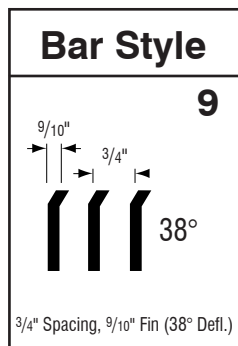
Material: Extruded aluminum
Lengths over 72 inches supplied as multiple sections

Opposed Blade Damper (optional):
Galvanized steel construction
Key-operated through grille face

Braces set at max 11"
(with -RF max 6")



ALB90 / ALB97



- ALB90 = Grille Only
- ALB97 = Grille + OBD
(Min Width 3")
- ALB90-L = Grille + Air Equalizing Deflector
(Min Width 4")
- ALB97-L = Grille + OBD + Air Equalizing Deflector
(Min Width 4")

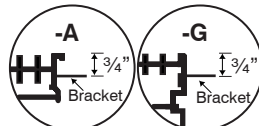
Margin Style			
<p>-A</p> <p>Listed + 9/32"</p> <p>9/16"</p> <p>Listed - 1/4"</p> <p>N/A with -3, -5, -RM, -SB</p>	<p>-B</p> <p>Listed + 7/8"</p> <p>7/8"</p> <p>Listed - 1/4"</p> <p>N/A with -5, -SB, -RM</p>	<p>-E</p> <p>Listed + 1 1/4"</p> <p>1 1/16"</p> <p>Listed - 1/4"</p> <p>N/A with -5, -SB, -RM</p>	<p>-F</p> <p>Listed + 1 3/8"</p> <p>1"</p> <p>Listed - 1/4"</p> <p>ONLY with -1, -3, -5, -RM</p>
<p>-G</p> <p>Listed - 1/4"</p> <p>3/16"</p> <p>Listed - 1/4"</p> <p>ONLY with -1, -5, -RM, -SB</p>	<p>-R</p> <p>Listed + 1 1/4"</p> <p>1 1/16"</p> <p>Listed - 1/4"</p> <p>N/A with -5, -SB, -RM</p>	<p>-T</p> <p>Listed - 1/4"</p> <p>1 1/16"</p> <p>Listed - 1 3/4"</p> <p>N/A with -2, -3, -5, -SB, -RM</p>	<p>-P Plaster-In Frame</p> <p>Listed + 1 1/4"</p> <p>Plaster</p> <p>Gyproc</p> <p>Listed - 1/4"</p> <p>ONLY with -5, -RM</p>

Fastening Method	
<p>-1 No Fastening</p> <p>N/A with -RM and frame -P</p>	<p>-2 Spring clip</p> <p>N/A with -F, -G, -P, -T</p>
<p>-3 Screw</p> <p>N/A with -A, -G, -T</p>	<p>-4 Concealed</p> <p>N/A with -F, -G, -P Min Width 4"</p>
<p>-5 Core spring clips</p> <p>Only with combined -RM and frames -F, -G, -P</p>	

Finish					
/W	/M	/A	/B	/L	/C Custom (Please Specify)
White (Default)	Mill Finish	Anodized	Brushed Aluminum N/A with -G, -R	Brushed & Lacquered N/A with -G, -R	



- Security Ceiling Wire -CW
- Mounting Brackets for Sheetrock -SB
(3/4" from the face) Only w/ -A -G
- Reinforced Floor Application -RF
(6" max width recommended for high traffic, 8" max width for occasional traffic)
- Removable Core Application -RM
Only w/ -F, -G
- Frame Gasket -GK
- Vertical Bars -V
- Debris Screen or Bird Screen (1/2" x 1/2" Mesh) -DS
- Insect Screen -IS



Up to 1/8 inch increments without damper.

Dimensions shown contain expansion tolerances based on temperature rise of 40°F above the ambient temperature at which the material is fabricated.

Schedule type: _____

Job: _____

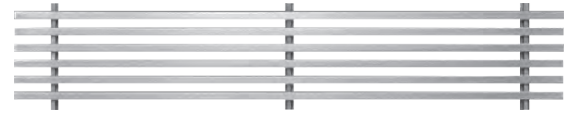
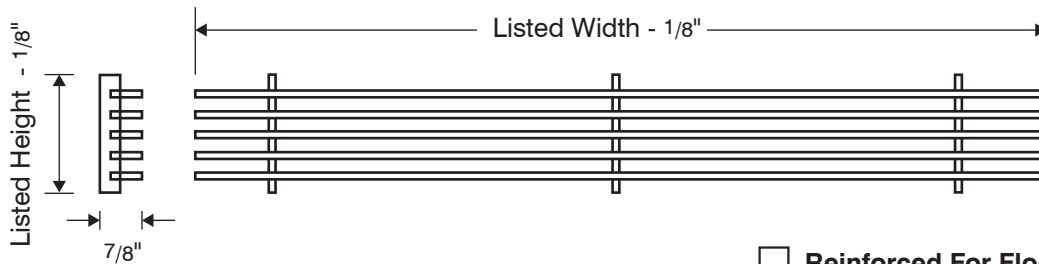
Architect: _____

Engineer: _____

Contractor: _____

ALBCO Linear Bar Grille - Core Only

Material: Extruded aluminum
 Length over 72 inches supplied as 2 or more sections


ALBCO6

 Reinforced For Floor Application -RF
 (Up to 6" wide)

Mounting	
<input type="checkbox"/>	-P Plaster-In Frame

Bar Style								
ALBCO1 Narrow	ALBCO2 	ALBCO3 	ALBCO4 	ALBCO5 	ALBCO6 Pencil Proof	ALBCO7 Pencil Proof	ALBCO8 	ALBCO9



Finish					
<input type="checkbox"/> /M Mill Finish	<input type="checkbox"/> /W White (default)	<input type="checkbox"/> /A Anodized	<input type="checkbox"/> /B Brushed	<input type="checkbox"/> /M Brushed & Lacquered	<input type="checkbox"/> /C Custom (please specify)

Schedule type: _____
Job: _____
Architect: _____
Engineer: _____
Contractor: _____

Dimensions shown contain expansion tolerances based on temperature rise of 40°F above the ambient temperature at which the material is fabricated.

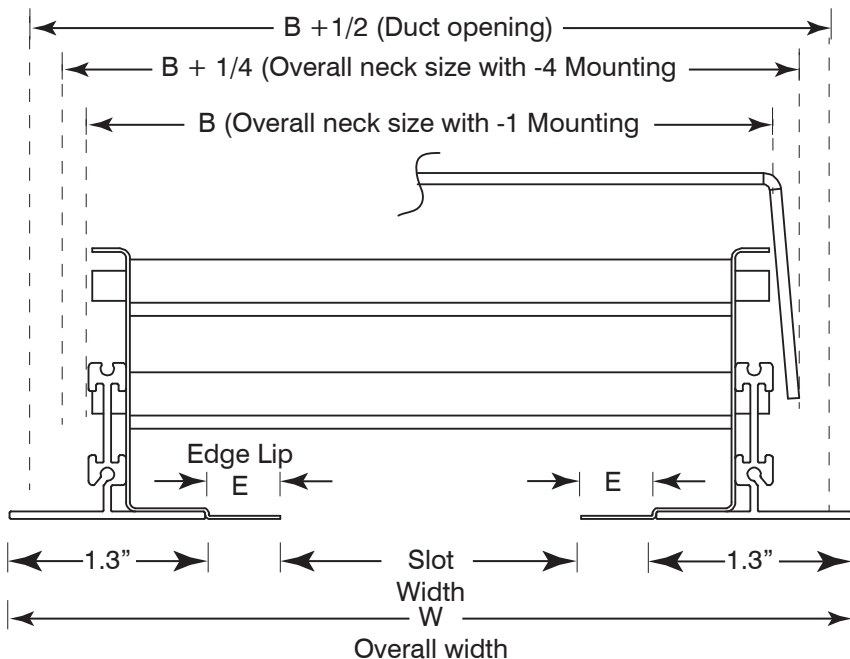
SUBMITTAL SHEET

LineAirFlow Diffuser - 1 Slot

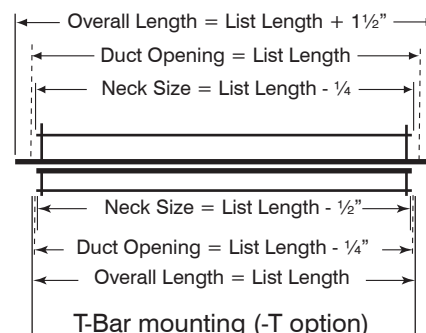
Material: Extruded aluminum construction
Mounting: Surface or Lay-in T-bar ceiling.
 Plaster-in Frame (Tape & Spackle)



ALF10 / ALF17 / ALF18
 (ALF17 shown here)



Surface mounting (-E and -P options)



Neck Size = List Length - 1/4"
 (only with -T option) Neck Size = List Length - 1/2"



ALF10
without pattern-control damper



ALF17
with high-flow slider



ALF18
with jet-flow baffles

Mounting		
<input type="checkbox"/> -P Plaster-In Frame	<input type="checkbox"/> -E Surface Mounting	<input type="checkbox"/> -T T-Bar mounting
Fastening Method		
<input type="checkbox"/> -1 No Fastening	<input type="checkbox"/> -3 Mounting Hole	<input type="checkbox"/> -4 Concealed

Option LS	
Optional Return Hool/Light Shield Model	
<input type="checkbox"/> -LS	
Finish	
<input type="checkbox"/> /W White (Default)	<input type="checkbox"/> /C Custom (Please Specify)



✓	SLOT WIDTH	B	W	C	E	H
	1	2.55"	3.6"	1.5"	0"	3.5"
	1.5	3.55"	4.6"	1.5"	0.25"	3.5"
	2	4.55"	5.6"	1.75"	0.5"	3.5"
	2.5	5.55"	6.6"	1.75"	0.75"	3.5"
	3	6.55"	7.6"	1.75"	1"	3.5"

Schedule type: _____
 Job: _____
 Architect: _____
 Engineer: _____
 Contractor: _____

Plenums for ALF Flow Bar Diffusers and Returns with 1 Slot

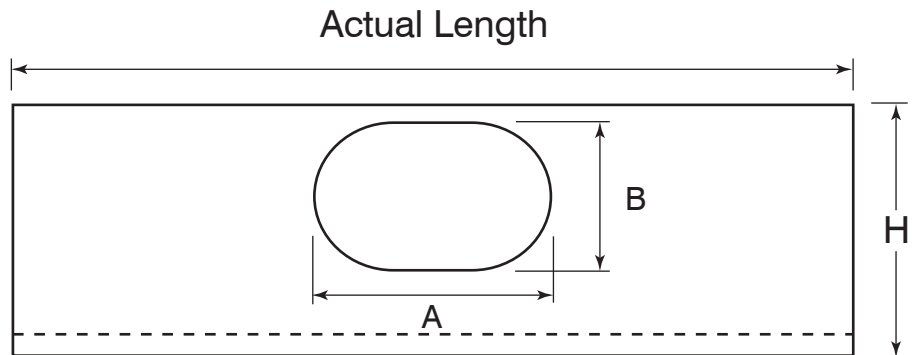
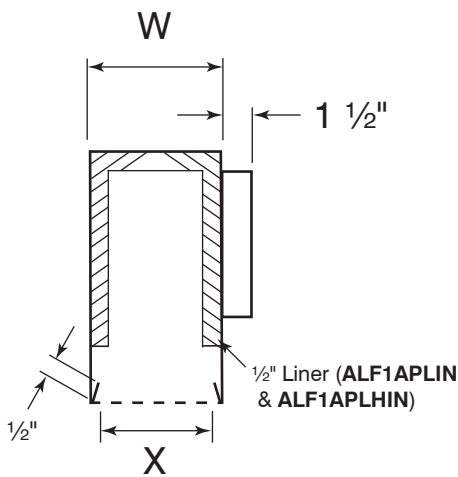
Material: 20 gauge Aluminum

ALF1APL
H = 7"

ALF1APLIN - 1/2" Liner Insulation
H = 7"

ALF1APLH
H = 10"

ALF1APLHIN - 1/2" Liner Insulation
H = 10"



✓	Inlet Size	With H=7"		With H=10"	
		A	B	A	B
	-04 4"	4"	4"	-	-
	-05 5"	5"	5"	-	-
	-06 6"	6 1/4"	5 1/4"	6"	6"
	-08 8"	9 3/8"	5 1/4"	8"	8"
	-10 10"	12 1/2"	5 1/4"	11"	8"
	-12* 12"	-	-	14 1/8"	8"
	-14* 14"	-	-	17 1/4"	8"

✓	SLOTS WIDTH	W	X
	1.0	3.4	2.95
	1.5	4.4	3.95
	2.0	5.4	4.95
	2.5	6.4	5.95
	3.0	7.4	6.95

*12" & 14" oval neck available only with 11" high plenums

ALF10/ALF18/ALF17 Mounting	
<input type="checkbox"/> -E Surface	Actual Length = Nominal Length
<input type="checkbox"/> -T T-bar Lay-in	Actual Length = Nominal Length - 1/4"
<input type="checkbox"/> -P Plaster-in	Actual Length = Nominal Length

Schedule type: _____

Job: _____

Architect: _____

Engineer: _____

Contractor: _____

Plenums for ALF Flow Bar Diffusers and Returns with 1 Slot

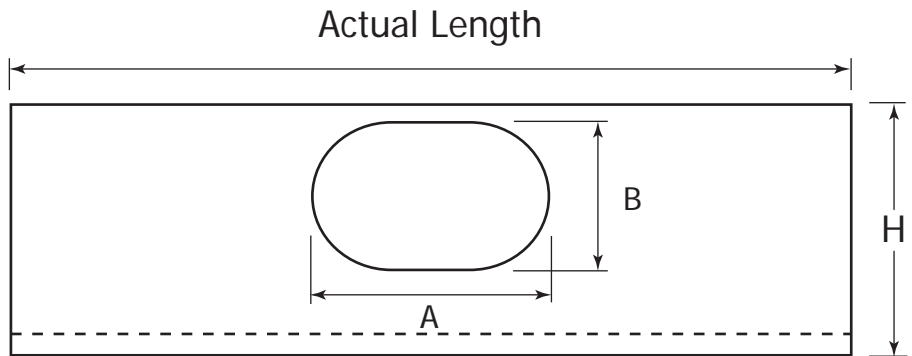
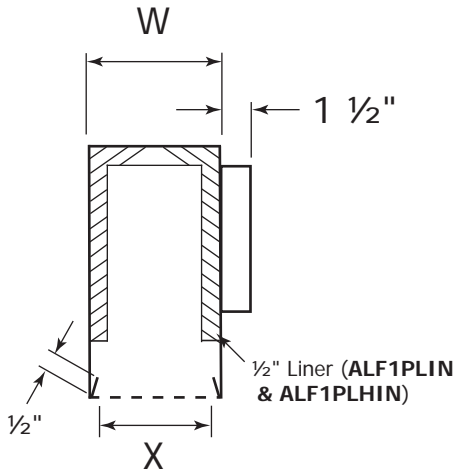
Material: 24 gauge galvanized

ALF1PL
H = 7"

ALF1PLIN - 1/2" Liner Insulation
H = 7"

ALF1PLH
H = 10"

ALF1PLHIN - 1/2" Liner Insulation
H = 10"



✓	Inlet Size	With H=7"		With H=10"	
		A	B	A	B
	-04 4"	4"	4"	-	-
	-05 5"	5"	5"	-	-
	-06 6"	6 1/4"	5 1/4"	6"	6"
	-08 8"	9 3/8"	5 1/4"	8"	8"
	-10 10"	12 1/2"	5 1/4"	11"	8"
	-12* 12"	-	-	14 1/8"	8"
	-14* 14"	-	-	17 1/4"	8"

✓	SLOTS WIDTH	W	X
	1.0	3.4	2.95
	1.5	4.4	3.95
	2.0	5.4	4.95
	2.5	6.4	5.95
	3.0	7.4	6.95

*12" & 14" oval neck available only with 11" high plenums

ALF10/ALF18/ALF17 Mounting	
<input type="checkbox"/> -E Surface	Actual Length = Nominal Length
<input type="checkbox"/> -T T-bar Lay-in	Actual Length = Nominal Length - 1/4"
<input type="checkbox"/> -P Plaster-in	Actual Length = Nominal Length

Schedule type: _____

Job: _____

Architect: _____

Engineer: _____

Contractor: _____

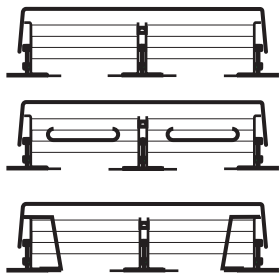
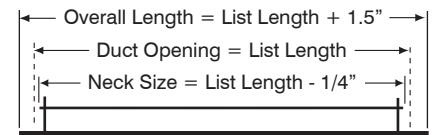
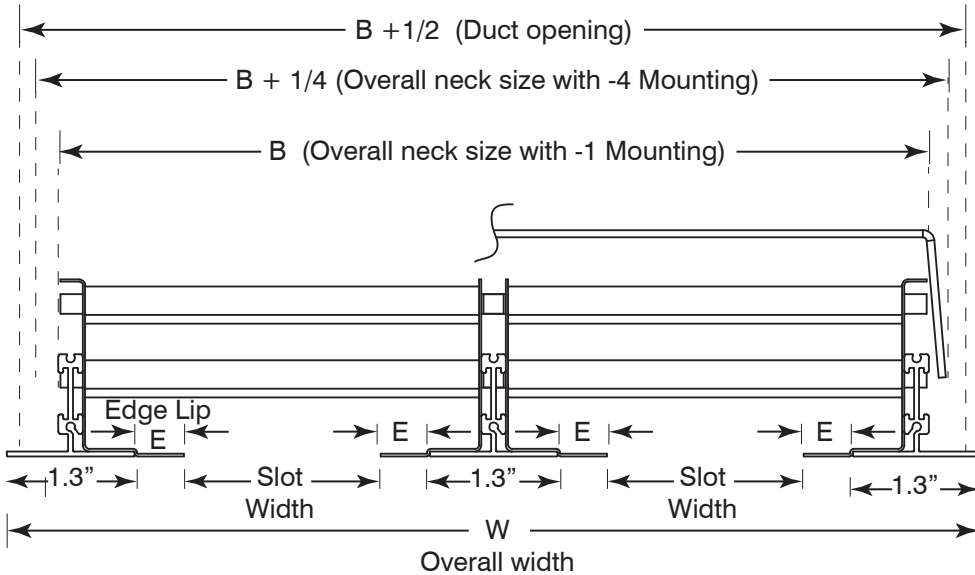
LineAirFlow Diffuser - 2 Slot

Material: Extruded aluminum construction
Mounting: Surface or Lay-in T-bar ceiling.
 Plaster-in Frame (Tape & Spackle)



ALF20 / ALF27 / ALF28
 (ALF27 shown here)

SUBMITTAL SHEET



- ALF20**
without pattern-control damper
- ALF27**
with high-flow slider
- ALF28**
with jet-flow baffles

Option LS
 Optional Return Hood/Light Shield Model

-LS

Mounting

-P Plaster-In Frame **-E** Surface Mounting

Fastening Method

-1 No Fastening **-4** Concealed

Finish

/W White (Default) **/C** Custom (Please Specify)



✓	SLOT WIDTH	B	W	C	E	H
	1	4.85"	5.9"	1.5"	0"	2.25"
	1.5	6.85"	7.9"	1.5"	0.25"	3.25"
	2	8.85"	9.9"	1.75"	0.5"	4.25"
	2.5	10.85"	11.9"	1.75"	0.75"	5.25"
	3	12.85"	13.9"	1.75"	1"	6.25"

Schedule type: _____

Job: _____

Architect: _____

Engineer: _____

Contractor: _____

Plenums for ALF Flow Bar Diffusers and Returns with 2 Slots

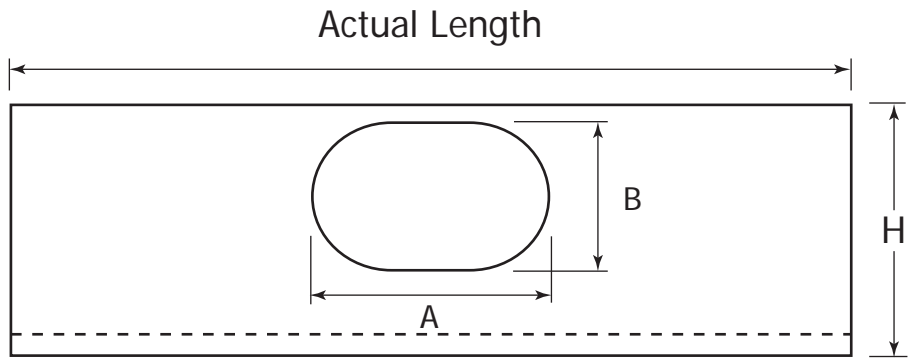
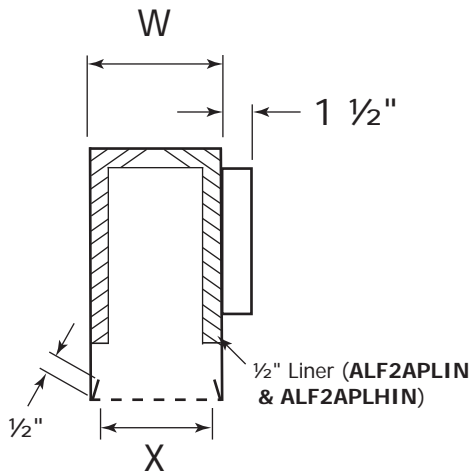
Material: 20 gauge Aluminum

ALF2APL
H = 10"

ALF2APLIN - 1/2" Liner Insulation
H = 10"

ALF2APLH
H = 16"

ALF2APLHIN - 1/2" Liner Insulation
H = 16"



✓		Inlet Size	With H=10"		With H=16"		✓	SLOTS WIDTH	W	X
			A	B	A	B				
	-08	8"	8"	8"	8"	8"		1.0	5.7	5.25
	-10	10"	10 15/16"	8"	10"	10"		1.5	7.7	7.25
	-12*	12"	14 3/32"	8"	12"	12"		2.0	9.7	9.25
	-14*	14"	17 1/4"	8"	14"	14"		2.5	11.7	11.25
								3.0	13.7	13.25

ALF20A/ALF28A/ALF27A Mounting		
<input type="checkbox"/> -E	Actual Surface Length =	Nominal Length
<input type="checkbox"/> -P	Actual Plaster-in Length =	Nominal Length

Schedule type: _____

Job: _____

Architect: _____

Engineer: _____

Contractor: _____

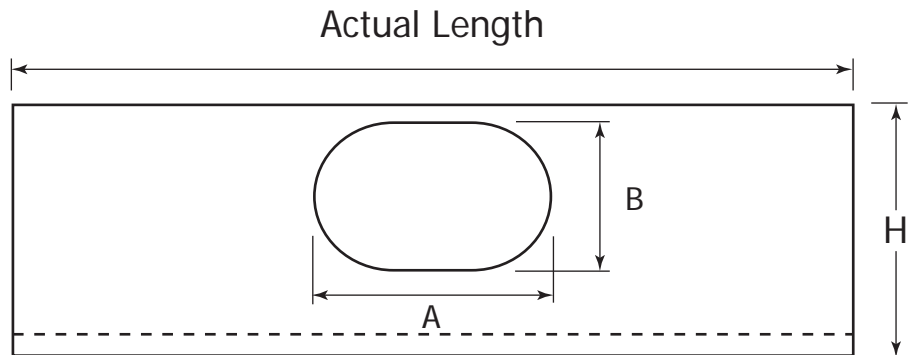
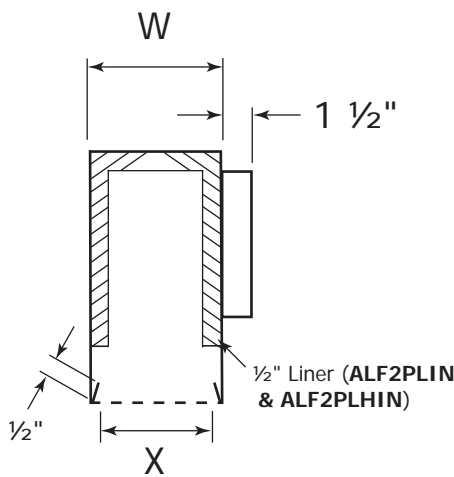
Plenums for ALF Flow Bar Diffusers and Returns with 2 Slots

Material: 24 gauge galvanized

 ALF2PL
H = 10"

 ALF2PLIN - 1/2" Liner Insulation
H = 10"

 ALF2PLH
H = 16"

 ALF2PLHIN - 1/2" Liner Insulation
H = 16"


✓		Inlet Size	With H=10"		With H=16"		✓	SLOTS WIDTH	W	X
			A	B	A	B				
	-08	8"	8"	8"	8"	8"		1.0	5.7	5.25
	-10	10"	10 15/16"	8"	10"	10"		1.5	7.7	7.25
	-12*	12"	14 3/32"	8"	12"	12"		2.0	9.7	9.25
	-14*	14"	17 1/4"	8"	14"	14"		2.5	11.7	11.25
								3.0	13.7	13.25

ALF10/ALF18/ALF17 Mounting		
<input type="checkbox"/>	-E Surface	Actual Length = Nominal Length
<input type="checkbox"/>	-T T-bar Lay-in	Actual Length = Nominal Length - 1/4"
<input type="checkbox"/>	-P Plaster-in	Actual Length = Nominal Length

Schedule type: _____

Job: _____

Architect: _____

Engineer: _____

Contractor: _____

SUBMITTAL SHEET

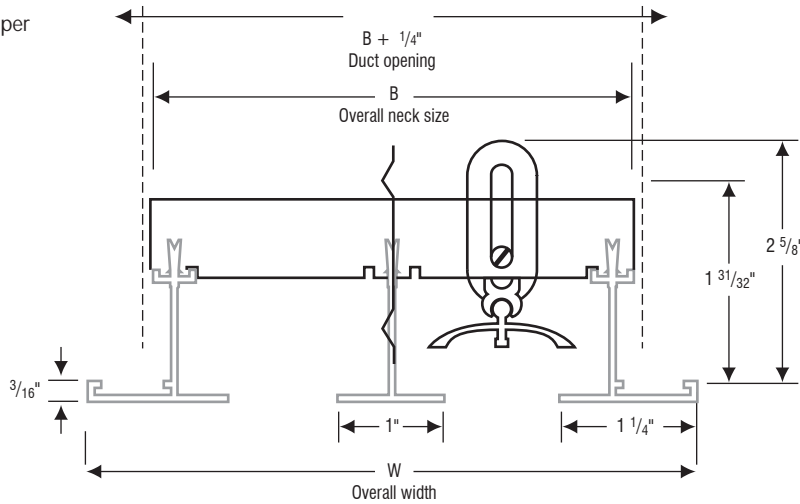
Linear 1" Slot Diffuser

Material: Extruded aluminum construction
Mounting: Surface or Lay-in T-bar ceiling.



ALS10 / ALS17

- ALS10**
without pattern-control damper
- ALS17**
with pattern-control damper



Frame Gasket -GK

Mounting

Surface mounting **-E**

T-bar mounting (N/A with -3) **-T**

Fastening Method

No Fastening **-1**

Screw **-3**

N/A with -T

Concealed **-4**

✓	NO. OF SLOTS	B	W
	01	2 3/8"	3 17/32"
	02	4 3/8"	5 17/32"
	03	6 3/8"	7 17/32"
	04	8 3/8"	9 17/32"
	05	10 3/8"	11 17/32"
	06	12 3/8"	13 17/32"
	07	14 3/8"	15 17/32"
	08	16 3/8"	17 17/32"

Finish

/W
White (Default)

/C Custom (Please Specify)



Schedule type: _____

Job: _____

Architect: _____

Engineer: _____

Contractor: _____

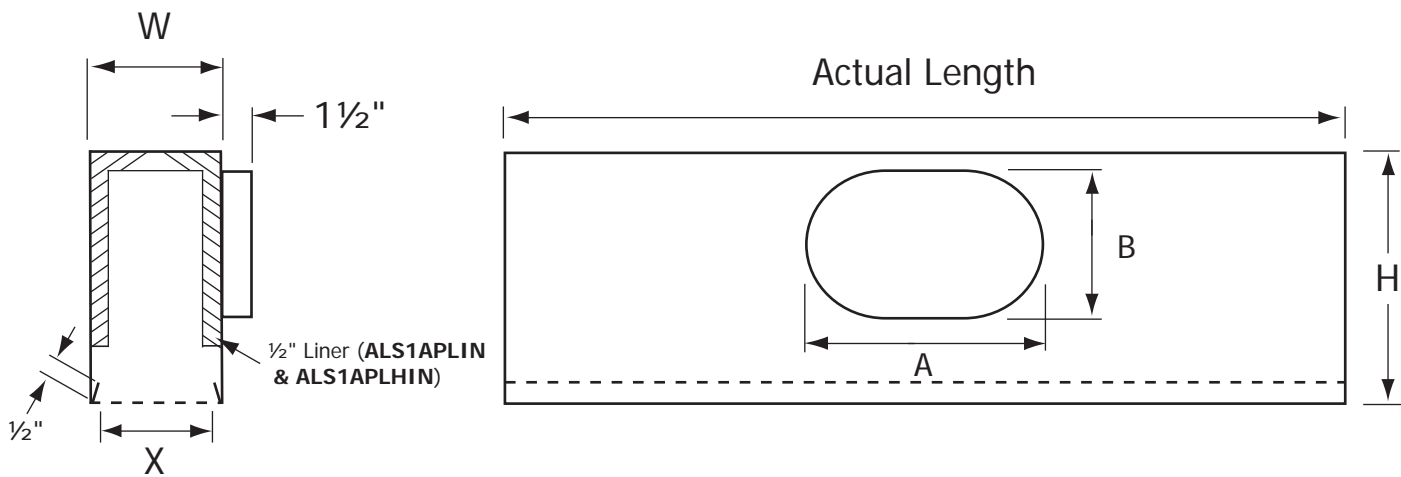
Plenums for ALS10/17 - 1" Slot Diffusers and Returns

Material: 24 gauge galvanized

 ALS1APL
H = 8"

 ALS1APLIN - 1/2" Liner Insulation
H = 8"

 ALS1APLH
H = 11"

 ALS1APLHIN - 1/2" Liner Insulation
H = 11"


ALS10/17 Mounting		
<input type="checkbox"/> -E Surface	Actual Length =	Nominal Length
<input type="checkbox"/> -T T-Bar	Actual Length =	Nominal Length - 1 1/8"

✓		Inlet Size	A	B
	-04	4"	4"	4"
	-05	5"	5"	5"
	-06	6"	6 1/4"	5 1/4"
	-08	8"	9 3/8"	5 1/4"
	-10	10"	12 1/2"	5 1/4"
	-12*	12"	14 1/8"	7 7/8"

* 12" oval neck available only with 11" high plenums

✓	NO. OF SLOTS	W	X
	01	3"	2 5/8"
	02	5"	4 5/8"
	03	7"	6 5/8"
	04	9"	8 5/8"
	05	11"	10 5/8"
	06	13"	12 5/8"
	07	15"	14 5/8"
	08	17"	16 5/8"

Schedule type: _____

Job: _____

Architect: _____

Engineer: _____

Contractor: _____

SUBMITTAL SHEET

Linear 1" Slot Diffuser - L-Shape

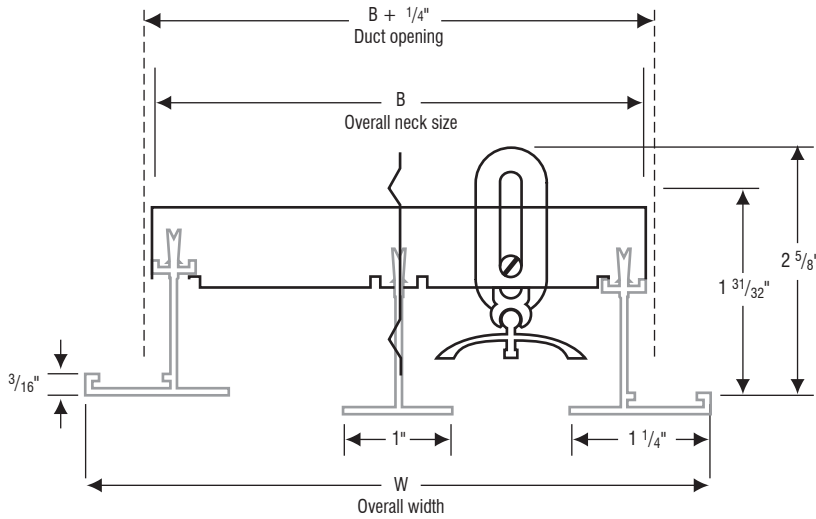
Material: Extruded aluminum construction
Mounting: Surface or Lay-in T-bar ceiling.

ALS10 (x=0)
without pattern-control damper

ALS17 (x=7)
with pattern-control damper



ALS10 / ALS17
(ALS17 two slots shown here)
Corner Section
(No deflector in corner section)



✓	NO. OF SLOTS	B	W	C
	01	2 3/8"	3 17/32"	12"
	02	4 3/8"	5 17/32"	12"
	03	6 3/8"	7 17/32"	12"
	04	8 3/8"	9 17/32"	16"
	05	10 3/8"	11 17/32"	16"
	06	12 3/8"	13 17/32"	20"
	07	14 3/8"	15 17/32"	20"
	08	16 3/8"	17 17/32"	24"

Frame Gasket -GK (gg=GK)

Mounting (m=E)

Surface mounting **-E**

Fastening Method (f=1, f=3 or f=4)

No Fastening **-1** | Screw **-3** | Concealed **-4**

N/A with -T

Finish

/W White (default) | /C Custom (please specify)



Dimension

H (in inches): _____"
 L (in inches): _____"
 D (in degrees): _____°

Dimension Type (dd=FS, dd=LS or dd=NS)

-FS Face Size | **-LS** List Size | **-NS** Exact Neck Size

Supplied in species as follows:
 1 pc. ALSEC1x-m-f-gg-dd HH #S /Finish
 1 pc. ALSEC1x-m-f-gg-dd LL #S /Finish
 1 pc. ALSMC1-m-f-gg-dd DD #S /Finish

Schedule type: _____
 Job: _____
 Architect: _____
 Engineer: _____
 Contractor: _____

Linear 1" Slot Diffuser - L-Shape

Material: Extruded aluminum construction

Mounting: Surface or Lay-in T-bar ceiling.

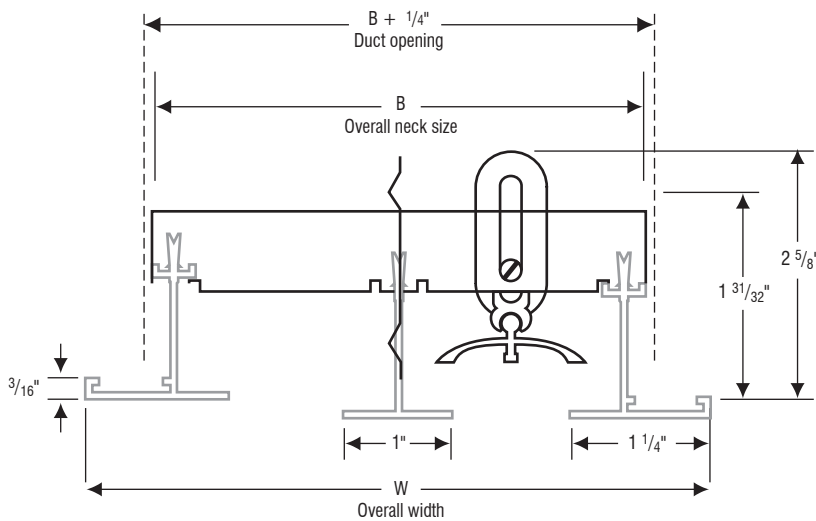


SUBMITTAL SHEET

ALS10 / ALS17
(ALS17 two slots shown here)

ALS10 (x=0)
without pattern-control damper

ALS17 (x=7)
with pattern-control damper



✓	NO. OF SLOTS #S	B	W
	01	2 3/8"	3 17/32"
	02	4 3/8"	5 17/32"
	03	6 3/8"	7 17/32"
	04	8 3/8"	9 17/32"
	05	10 3/8"	11 17/32"
	06	12 3/8"	13 17/32"
	07	14 3/8"	15 17/32"
	08	16 3/8"	17 17/32"

Frame Gasket -GK (gg=GK)

Mounting (m=E)

Surface mounting **-E**

Dimension

H (in inches): _____"

L (in inches): _____"

D (in degrees): _____°

Dimension Type (dd=FS, dd=LS or dd=NS)

<input type="checkbox"/> -FS Face Size	<input type="checkbox"/> -LS List Size	<input type="checkbox"/> -NS Exact Neck Size
--	--	--

Yields the following:

- 1 pc. ALSEC1x-m-f-gg-dd HH #S /Finish
- 1 pc. ALSEC1x-m-f-gg-dd LL #S /Finish
- 1 pc. ALSMC1-m-f-gg-dd DD #S /Finish

Fastening Method (f=1, f=3 or f=4)

No Fastening -1	Screw -3	Concealed -4
	 N/A with -T	

Finish

<input type="checkbox"/> /W White (default)	<input type="checkbox"/> /C Custom (please specify)
--	--



Schedule type: _____

Job: _____

Architect: _____

Engineer: _____

Contractor: _____

Plenums for ALS10/17 - 1" Slot Diffusers and Returns

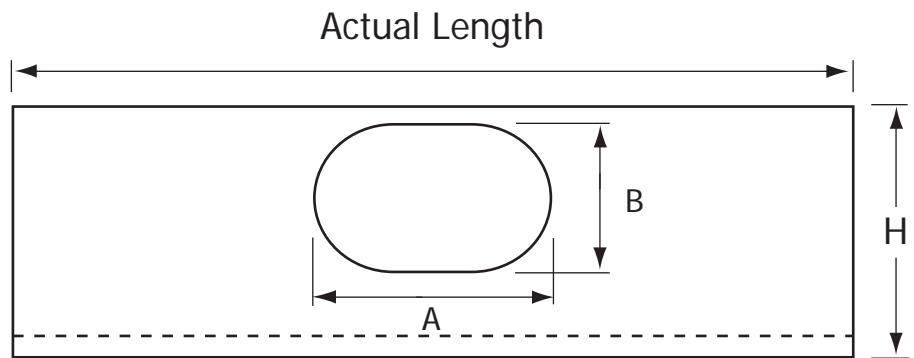
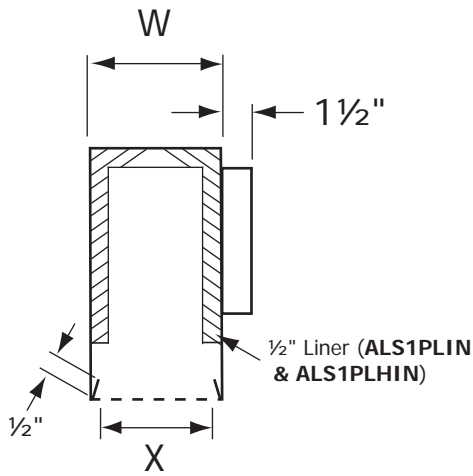
Material: 24 gauge galvanized

ALS1PL
H = 8"

ALS1PLIN - 1/2" Liner Insulation
H = 8"

ALS1PLH
H = 11"

ALS1PLHIN - 1/2" Liner Insulation
H = 11"



ALS10/17 Mounting	
<input type="checkbox"/> -E Surface	Actual Length = Nominal Length
<input type="checkbox"/> -T T-Bar	Actual Length = Nominal Length - 1 1/8"

✓		Inlet Size	A	B
	-04	4"	4"	4"
	-05	5"	5"	5"
	-06	6"	6 1/4"	5 1/4"
	-08	8"	9 3/8"	5 1/4"
	-10	10"	12 1/2"	5 1/4"
	-12*	12"	14 1/8"	7 7/8"

* 12" oval neck available only with 11" high plenums

✓	NO. OF SLOTS	W	X
	01	3"	2 5/8"
	02	5"	4 5/8"
	03	7"	6 5/8"
	04	9"	8 5/8"
	05	11"	10 5/8"
	06	13"	12 5/8"
	07	15"	14 5/8"
	08	17"	16 5/8"

Schedule type: _____

Job: _____

Architect: _____

Engineer: _____

Contractor: _____

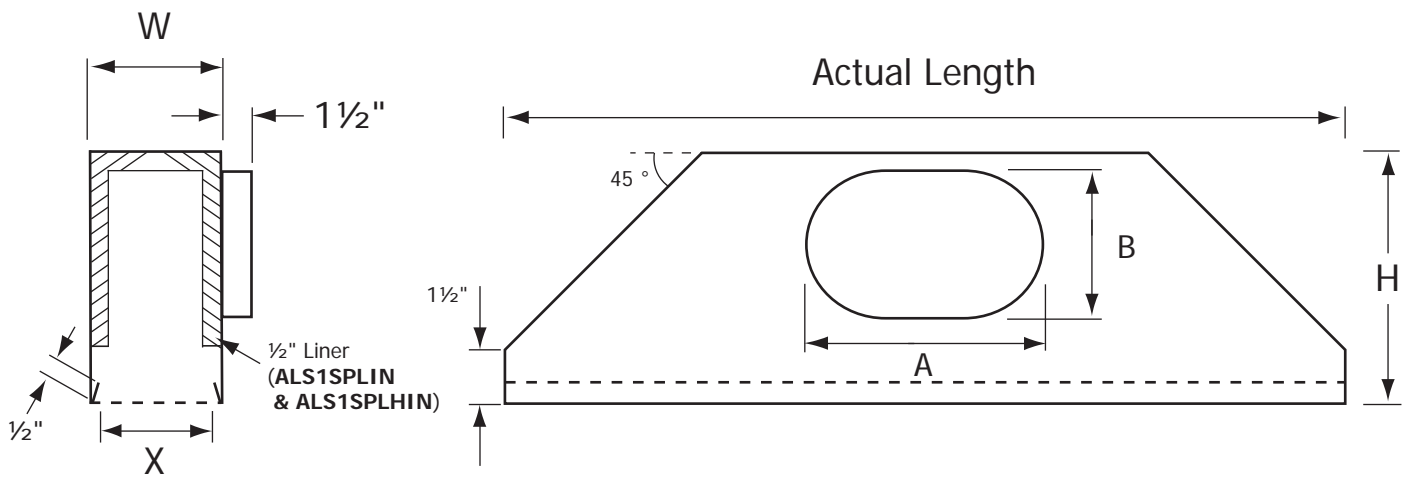
Plenums for ALS10SPL/17SPL - 1" Slot Diffusers and Returns

Material: 24 gauge galvanized

 ALS1SPL
H = 8"

 ALS1SPLIN - 1/2" Liner Insulation
H = 8"

 ALS1SPLH
H = 11"

 ALS1SPLHIN - 1/2" Liner Insulation
H = 11"


ALS10/17 Mounting		
<input type="checkbox"/> -E Surface	Actual Length =	Nominal Length
<input type="checkbox"/> -T T-Bar	Actual Length =	Nominal Length - 1 1/8"

✓		Inlet Size	A	B
	-04	4"	4"	4"
	-05	5"	5"	5"
	-06	6"	6 1/4"	5 1/4"
	-08	8"	9 3/8"	5 1/4"
	-10	10"	12 1/2"	5 1/4"
	-12*	12"	14 1/8"	7 7/8"

* 12" oval neck available only with 11" high plenums

✓	NO. OF SLOTS	W	X
	01	3"	2 5/8"
	02	5"	4 5/8"
	03	7"	6 5/8"
	04	9"	8 5/8"
	05	11"	10 5/8"
	06	13"	12 5/8"
	07	15"	14 5/8"
	08	17"	16 5/8"

Schedule type: _____

Job: _____

Architect: _____

Engineer: _____

Contractor: _____

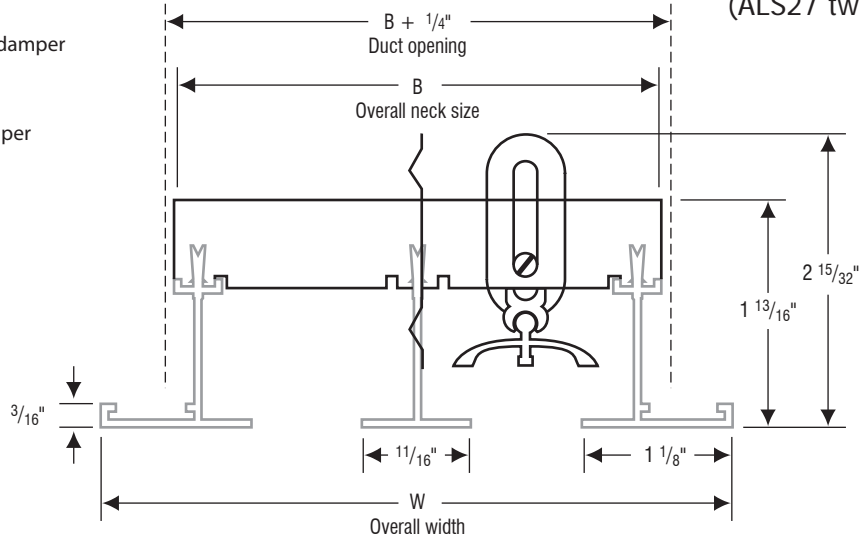
Linear 1/2" Slot Diffuser

Material: Extruded aluminum construction
Mounting: Surface or Lay-in T-bar ceiling



ALS20 / ALS27
 (ALS27 two slots shown here)

- ALS20**
without pattern-control damper
- ALS27**
with pattern-control damper



Frame Gasket -GK

Mounting	
Surface mounting	-E
	-T
T-bar mounting (N/A with -3)	

✓	NO. OF SLOTS	B	W
	01	1 9/16"	2 23/32"
	02	2 3/4"	3 29/32"
	03	3 15/16"	5 3/32"
	04	5 1/8"	6 9/32"
	05	6 5/16"	7 15/32"
	06	7 1/2"	8 21/32"
	07	8 11/16"	9 27/32"
	08	9 7/8"	11 1/32"



Fastening Method		
No Fastening -1	Screw -3	Concealed -4
	N/A with -T	

Finish	
White <input type="checkbox"/>	Custom <input type="checkbox"/> <small>(please specify)</small>

Schedule type: _____
Job: _____
Architect: _____
Engineer: _____
Contractor: _____

Plenums for ALS20/27 - 1/2" Slot Diffusers and Returns

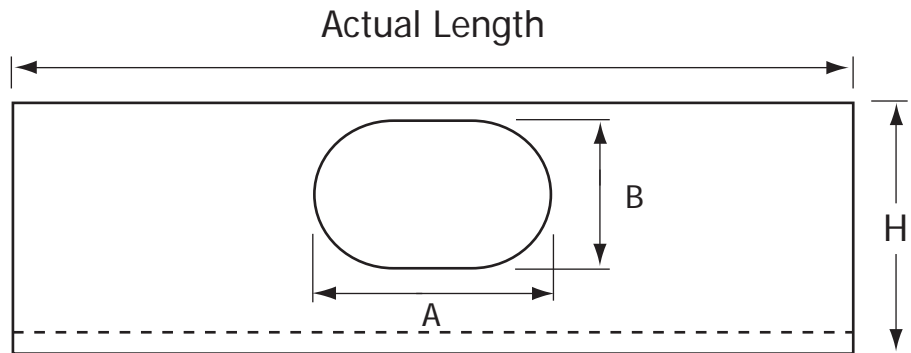
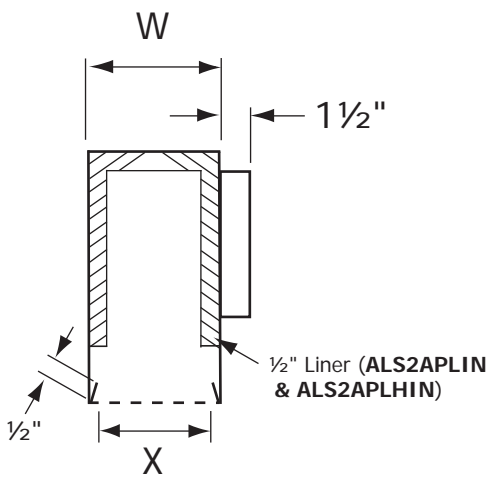
Material: 20 gauge aluminum

ALS2PL
H = 8"

ALS2PLIN - 1/2" Liner Insulation
H = 8"

ALS2PLH
H = 11"

ALS2PLHIN - 1/2" Liner Insulation
H = 11"



ALS20/27 Mounting		
<input type="checkbox"/> -E Surface	Actual Length =	Nominal Length
<input type="checkbox"/> -T T-Bar	Actual Length =	Nominal Length - 1 1/8"

✓		Inlet Size	A	B
	-04	4"	4"	4"
	-05	5"	5"	5"
	-06	6"	6 1/4"	5 1/4"
	-08	8"	9 3/8"	5 1/4"
	-10	10"	12 1/2"	5 1/4"
	-12*	12"	14 1/8"	7 7/8"

* 12" oval neck available only with 11" high plenums

✓	NO. OF SLOTS	W	X
			1 13/16"
			3"
			4 3/16"
			5 3/8"
			6 9/16"
			7 3/4"
			8 15/16"
			10 1/8"

Schedule type: _____

Job: _____

Architect: _____

Engineer: _____

Contractor: _____

Plenums for ALS20/27 - 1/2" Slot Diffusers and Returns

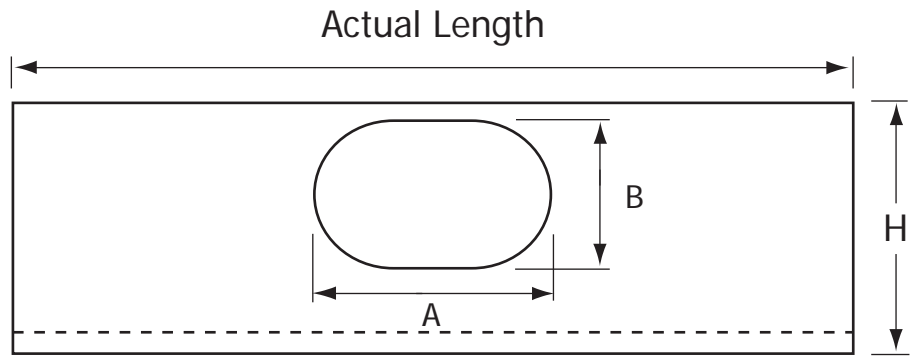
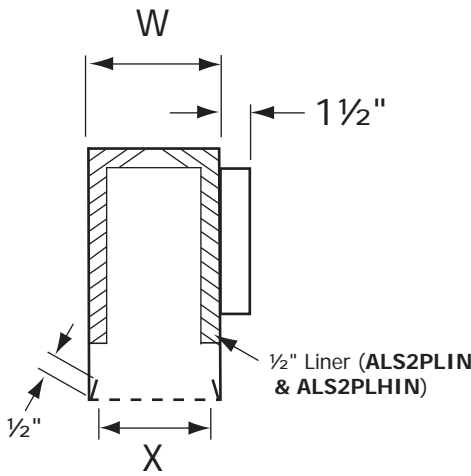
Material: 24 gauge galvanized

ALS2PL
H = 8"

ALS2PLIN - 1/2" Liner Insulation
H = 8"

ALS2PLH
H = 11"

ALS2PLHIN - 1/2" Liner Insulation
H = 11"



ALS20/27 Mounting		
<input type="checkbox"/> -E Surface	Actual Length =	Nominal Length
<input type="checkbox"/> -T T-Bar	Actual Length =	Nominal Length - 1 1/8"

✓		Inlet Size	A	B
	-04	4"	4"	4"
	-05	5"	5"	5"
	-06	6"	6 1/4"	5 1/4"
	-08	8"	9 3/8"	5 1/4"
	-10	10"	12 1/2"	5 1/4"
	-12*	12"	14 1/8"	7 7/8"

* 12" oval neck available only with 11" high plenums

✓	NO. OF SLOTS	W	X
			1 13/16"
			3"
			4 3/16"
			5 3/8"
			6 9/16"
			7 3/4"
			8 15/16"
			10 1/8"

Schedule type: _____

Job: _____

Architect: _____

Engineer: _____

Contractor: _____

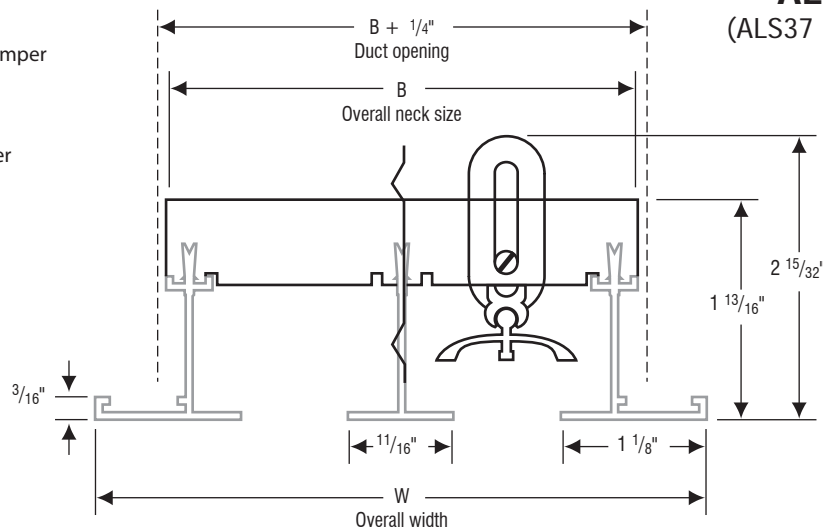
Linear 3/4" Slot Diffuser

Material: Extruded aluminum construction
Mounting: Surface or Lay-in T-bar ceiling.



ALS30
without pattern-control damper

ALS37
with pattern-control damper



ALS30 / ALS37
(ALS37 two slots shown here)

Frame Gasket -GK

Style	
<p>Surface mounting -E</p> <p>Overall Length = List Length + 7/8"</p> <p>Duct Opening = List Length</p> <p>Neck Size = List Length - 1/4"</p>	<input type="checkbox"/>
<p>T-bar mounting (N/A with -3) -T</p> <p>Neck Size = List Length - 13/8"</p> <p>Duct Opening = List Length - 11/8"</p> <p>Overall Length = List Length - 1/4"</p>	<input type="checkbox"/>

✓	NO. OF SLOTS	B	W
	01	1 13/16"	2 31/32"
	02	3 1/4"	4 13/32"
	03	4 11/16"	5 27/32"
	04	6 1/8"	7 9/32"
	05	7 9/16"	8 23/32"
	06	9"	10 5/32"
	07	10 7/16"	11 19/32"
	08	11 7/8"	13 1/32"



Fastening Method		
<p>No Fastening -1</p>	<p>Screw -3</p> <p>N/A with -T</p>	<p>Concealed -4</p>

Finish	
<input type="checkbox"/> White	<input type="checkbox"/> Custom (please specify)

Schedule type: _____

Job: _____

Architect: _____

Engineer: _____

Contractor: _____

Plenums for ALS30/37 - 3/4" Slot Diffusers and Returns

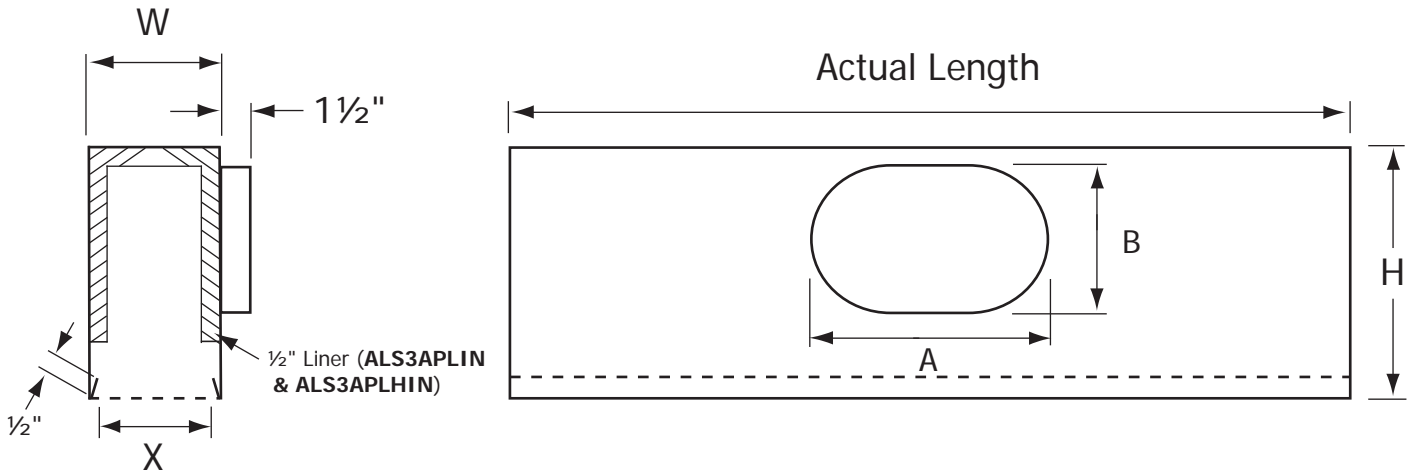
Material: 20 gauge aluminum

ALSA3APL
H = 8"

ALSA3APLIN - 1/2" Liner Insulation
H = 8"

ALSA3APLH
H = 11"

ALS3APLHIN - 1/2" Liner Insulation
H = 11"



ALS30/37 Mounting		
<input type="checkbox"/> -E Surface	Actual Length =	Nominal Length
<input type="checkbox"/> -T T-Bar	Actual Length =	Nominal Length - 1 1/8"

✓		Inlet Size	A	B
	-04	4"	4"	4"
	-05	5"	5"	5"
	-06	6"	6 1/4"	5 1/4"
	-08	8"	9 3/8"	5 1/4"
	-10	10"	12 1/2"	5 1/4"
	-12*	12"	14 1/8"	7 7/8"

* 12" oval neck available only with 11" high plenums

✓	NO. OF SLOTS	W	X
	01	2 7/16"	2 1/16"
	02	3 3/8"	3 1/2"
	03	5 5/16"	4 15/16"
	04	6 3/4"	6 3/8"
	05	8 3/16"	7 13/16"
	06	9 5/8"	9 1/4"
	07	11 1/16"	10 11/16"
	08	12 1/2"	12 1/8"

Schedule type: _____

Job: _____

Architect: _____

Engineer: _____

Contractor: _____

Plenums for ALS30/37 - 3/4" Slot Diffusers and Returns

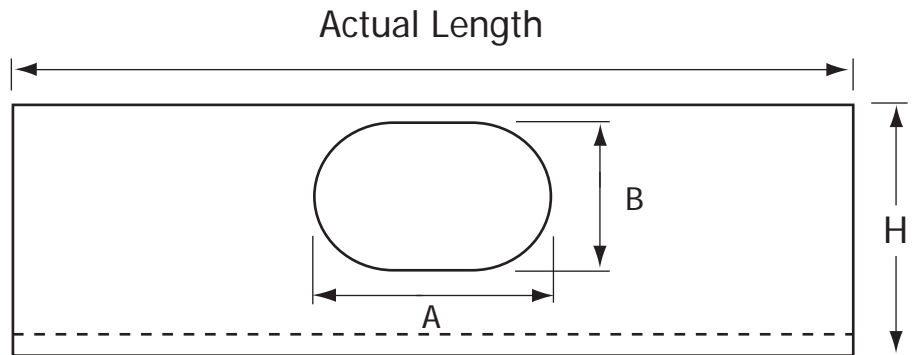
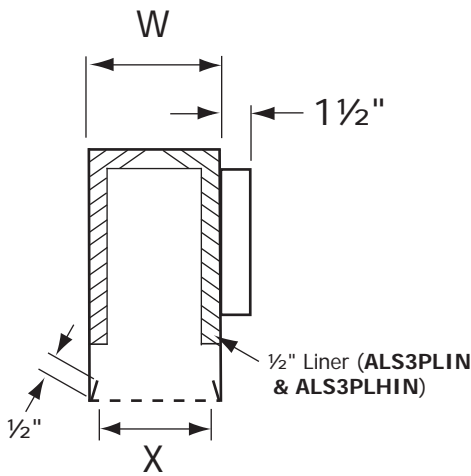
Material: 24 gauge galvanized

ALS3PL
H = 8"

ALS3PLIN - 1/2" Liner Insulation
H = 8"

ALS3PLH
H = 11"

ALS3PLHIN - 1/2" Liner Insulation
H = 11"



ALS30/37 Mounting		
<input type="checkbox"/> -E Surface	Actual Length =	Nominal Length
<input type="checkbox"/> -T T-Bar	Actual Length =	Nominal Length - 1 1/8"

✓		Inlet Size	A	B
	-04	4"	4"	4"
	-05	5"	5"	5"
	-06	6"	6 1/4"	5 1/4"
	-08	8"	9 3/8"	5 1/4"
	-10	10"	12 1/2"	5 1/4"
	-12*	12"	14 1/8"	7 7/8"

✓	NO. OF SLOTS	W	X
	01	2 7/16"	2 1/16"
	02	3 3/8"	3 1/2"
	03	5 5/16"	4 15/16"
	04	6 3/4"	6 3/8"
	05	8 3/16"	7 13/16"
	06	9 5/8"	9 1/4"
	07	11 1/16"	10 11/16"
	08	12 1/2"	12 1/8"

* 12" oval neck available only with 11" high plenums

Schedule type: _____

Job: _____

Architect: _____

Engineer: _____

Contractor: _____

SUBMITTAL SHEET

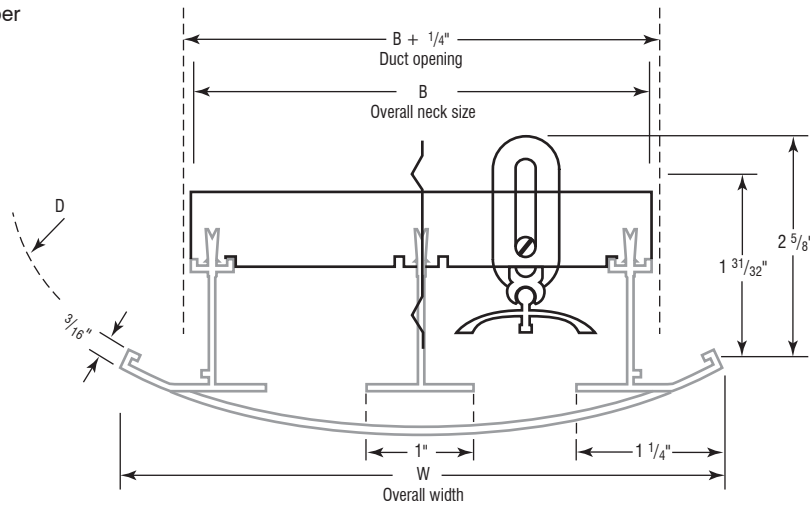
Linear 1" Slot Diffuser for Round Ducts

Material: Extruded aluminum construction

Mounting: Surface for round ducts

ALSD10
without pattern-control damper

ALSD17
with pattern-control damper



Frame Gasket -GK

✓	NO. OF SLOTS	B	W
	01	2 ³ / ₈ "	3 ¹⁷ / ₃₂ "
	02	4 ³ / ₈ "	5 ¹⁷ / ₃₂ "
	03	6 ³ / ₈ "	7 ¹⁷ / ₃₂ "
	04	8 ³ / ₈ "	9 ¹⁷ / ₃₂ "

✓	Duct D	Duct cut out opening			
		1 slot	2 slots	3 slots	4 slots
	10	2 ³ / ₈ "	4 ¹ / ₂ "		
	12	2 ³ / ₈ "	4 ¹ / ₂ "	6 ³ / ₄ "	
	14	2 ³ / ₈ "	4 ¹ / ₂ "	6 ⁵ / ₈ "	9"
	16	2 ³ / ₈ "	4 ¹ / ₂ "	6 ¹ / ₂ "	8 ³ / ₄ "
	18	2 ³ / ₈ "	4 ³ / ₈ "	6 ¹ / ₂ "	8 ³ / ₄ "
	20	2 ³ / ₈ "	4 ³ / ₈ "	6 ¹ / ₂ "	8 ⁵ / ₈ "
	24	2 ³ / ₈ "	4 ³ / ₈ "	6 ¹ / ₂ "	8 ¹ / ₂ "
	30	2 ³ / ₈ "	4 ³ / ₈ "	6 ³ / ₈ "	8 ¹ / ₂ "
	40&over	2 ³ / ₈ "	4 ³ / ₈ "	6 ³ / ₈ "	8 ³ / ₈ "

Mounting dimensions (length)

-E Surface mounting

Overall Length = List Length + $7/8"$
 Duct Opening = List Length
 Neck Size = List Length - $1/4"$

Fastening Method

-1 No Fastening

-3 Screw

-4 Concealed

Finish

/W White (Default)

/C Custom (Please Specify)



Schedule type: _____

Job: _____

Architect: _____

Engineer: _____

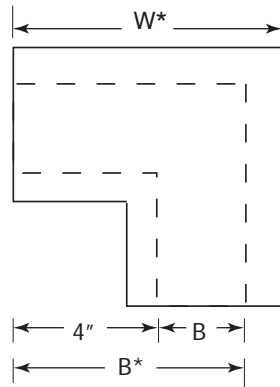
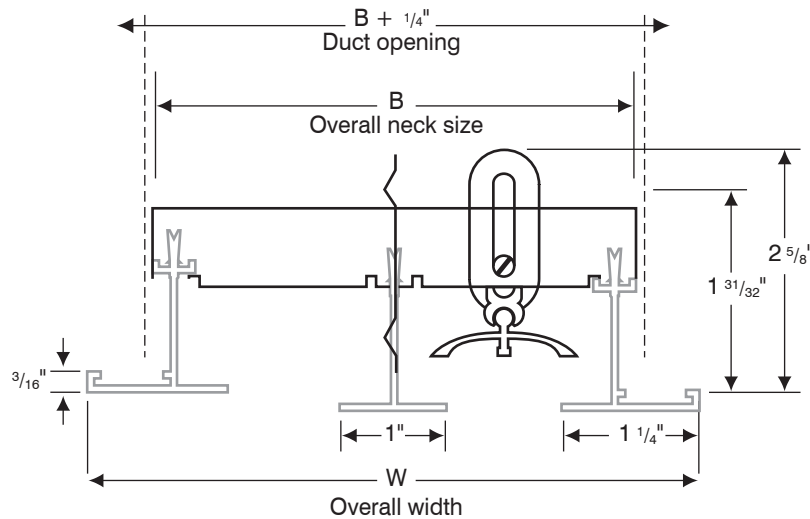
Contractor: _____



SUBMITTAL SHEET

Linear 1" Slot Diffuser - Mitered Corner

Material: Extruded aluminum construction
Mounting: Surface or Lay-in T-bar ceiling.

ALSMC1

 Frame Gasket -GK

✓	NO. OF SLOTS	B	W	B*	W*
	01	2 3/8"	3 17/32"	6 3/8"	6 61/64"
	02	4 3/8"	5 17/32"	8 3/8"	8 61/64"
	03	6 3/8"	7 17/32"	10 3/8"	10 61/64"
	04	8 3/8"	9 17/32"	12 3/8"	12 61/64"
	05	10 3/8"	11 17/32"	14 3/8"	14 61/64"
	06	12 3/8"	13 17/32"	16 3/8"	16 61/64"
	07	14 3/8"	15 17/32"	18 3/8"	18 61/64"
	08	16 3/8"	17 17/32"	20 3/8"	20 61/64"

Mounting	
<input type="checkbox"/> -E Surface mounting	<input type="checkbox"/> -T T-bar mounting (N/A with -3)

Finish	
<input type="checkbox"/> /W White (Default)	<input type="checkbox"/> /C Custom (Please Specify)



Fastening Method		
<input type="checkbox"/> -1 No Fastening	<input type="checkbox"/> -3 Screw N/A with -T	<input type="checkbox"/> -4 Concealed

Schedule type: _____

Job: _____

Architect: _____

Engineer: _____

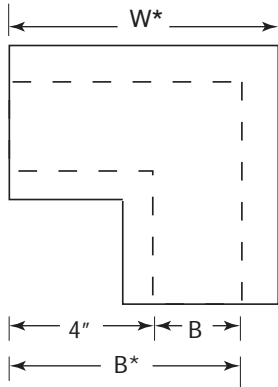
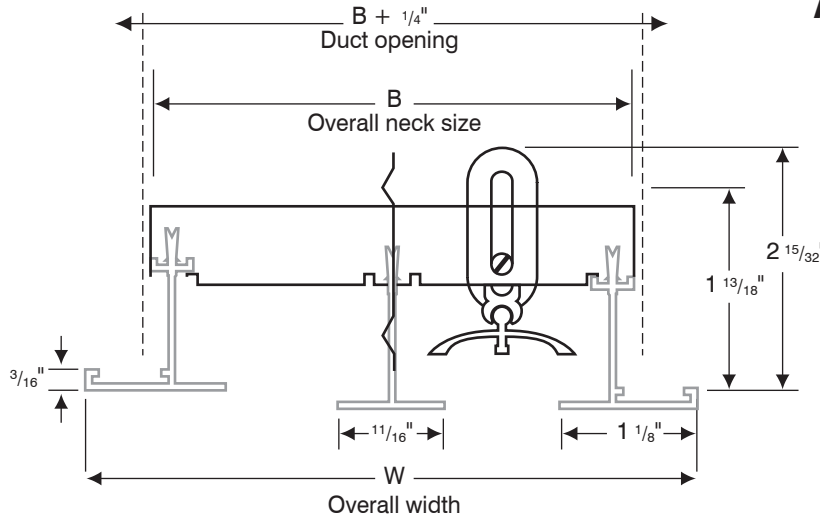
Contractor: _____

Linear 1/2" Slot Diffuser - Mitered Corner

Material: Extruded aluminum construction
Mounting: Surface or Lay-in T-bar ceiling.



ALSMC2



Frame Gasket -GK

✓	NO. OF SLOTS	B	W	B*	W*
	01	1 9/16"	2 23/32"	5 9/16"	6 9/64"
	02	2 3/4"	3 29/32"	6 3/4"	7 21/64"
	03	3 15/16"	5 3/32"	7 15/16"	8 33/64"
	04	5 1/8"	6 9/32"	9 1/8"	9 45/64"
	05	6 15/16"	7 15/32"	10 15/16"	11 33/64"
	06	7 1/2"	8 21/32"	11 1/2"	12 5/64"
	07	8 11/16"	9 27/32"	12 11/16"	13 3/10"
	08	9 7/8"	11 1/32"	13 7/8"	14 39/64"

Mounting	
<input type="checkbox"/> -E Surface mounting	<input type="checkbox"/> -T T-bar mounting (N/A with -3)

Fastening Method		
<input type="checkbox"/> -1 No Fastening	<input type="checkbox"/> -3 Screw N/A with -T	<input type="checkbox"/> -4 Concealed

Finish	
<input type="checkbox"/> /W White (Default)	<input type="checkbox"/> /C Custom (Please Specify)



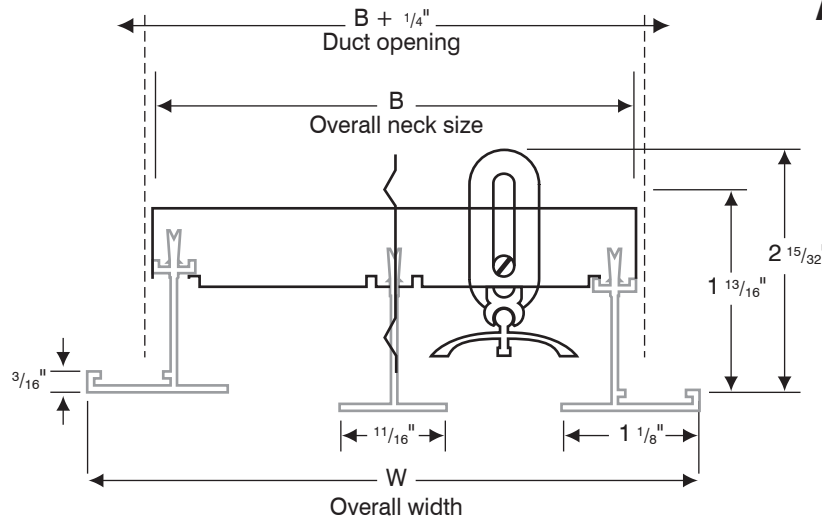
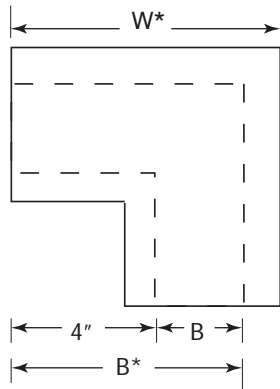
Schedule type: _____
 Job: _____
 Architect: _____
 Engineer: _____
 Contractor: _____



SUBMITTAL SHEET

Linear 3/4" Slot Diffuser - Mitered Corner

Material: Extruded aluminum construction
Mounting: Surface or Lay-in T-bar ceiling.


ALSMC3


✓	NO. OF SLOTS	B	W	B*	W*
	01	1 13/16"	2 31/32"	5 13/16"	5 35/64"
	02	3 1/4"	4 13/32"	7 1/4"	4 63/64"
	03	4 11/16"	5 27/32"	8 11/16"	6 27/64"
	04	6 1/8"	7 9/32"	10 1/8"	7 55/64"
	05	7 9/16"	8 23/32"	11 9/16"	11 19/64"
	06	9"	10 5/32"	13"	10 47/64"
	07	10 9/16"	11 19/32"	14 9/16"	12 11/64"
	08	11 9/16"	13 1/32"	15 9/16"	13 39/64"

 Frame Gasket -GK

Mounting	
<input type="checkbox"/> -E Surface mounting	<input type="checkbox"/> -T T-bar mounting (N/A with -3)

Fastening Method		
<input type="checkbox"/> -1 No Fastening	<input type="checkbox"/> -3 Screw N/A with -T	<input type="checkbox"/> -4 Concealed

Finish	
<input type="checkbox"/> /W White (Default)	<input type="checkbox"/> /C Custom (Please Specify)



Schedule type: _____

Job: _____

Architect: _____

Engineer: _____

Contractor: _____

SUBMITTAL SHEET

ARCH Architectural Sidewall Linear Bar Grille

Material: Extruded aluminum

Opposed Blade Damper (optional): Key-operated through grille face or by removing core

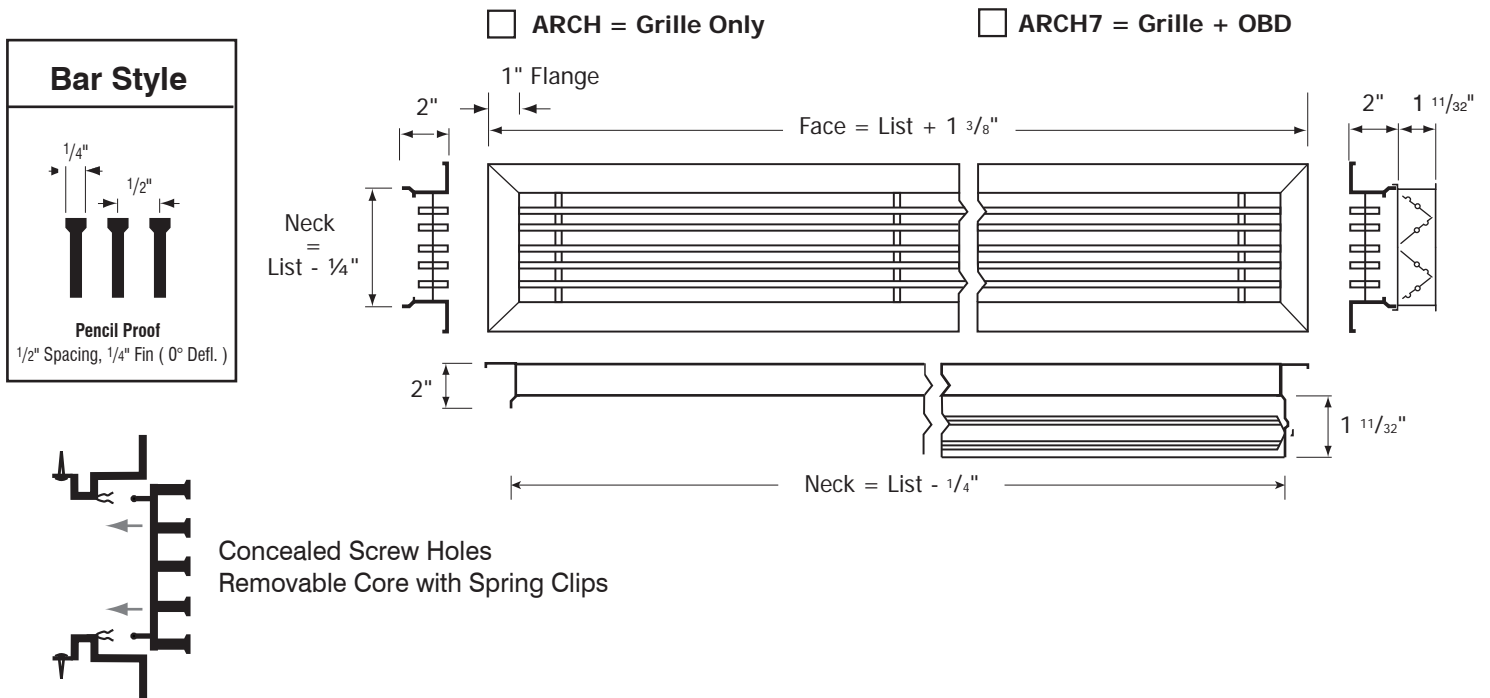
Other Styles Available: Order using ALB model and switch options

Equivalent ARCH = ALB60-F-5-RM

Equivalent ARCH7 = ALB67-F-5-RM



ARCH / ARCH7



Finish					
<input type="checkbox"/> /W Powder Coated White	<input type="checkbox"/> /M Mill Finish	<input type="checkbox"/> /SI Silver Aluminum Powder Coat	<input type="checkbox"/> /B Brushed Aluminum	<input type="checkbox"/> /L Brushed and Lacquered	<input type="checkbox"/> /Custom Specify here

Options	
<input type="checkbox"/> -CW Security Ceiling Wire	<input type="checkbox"/> -GK Frame Gasket

Schedule type: _____

Job: _____

Architect: _____

Engineer: _____

Contractor: _____

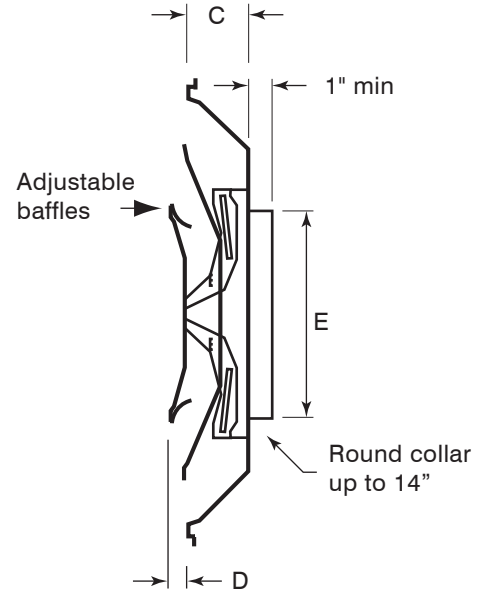
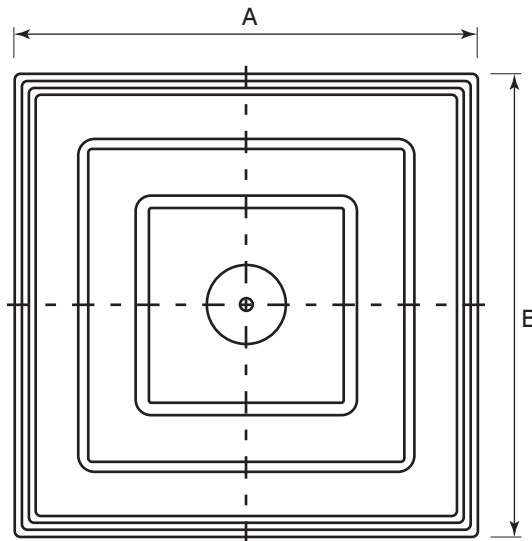
Dimensions shown contain expansion tolerances based on temperature rise of 40°F above the ambient temperature at which the material is fabricated.

Ceiling Supply Air Diffuser 3 Cone Adjustable

Material: Stamped heavy gauge steel.
Finish: Powder paint coating - white.
Air Pattern: Adjustable air pattern from horizontal for cooling to vertical for heating, full face.
Mounting: Surface or lay-in T-bar ceiling.
Core Removal: Unlock hanger brackets by swiveling lever down. Holding cone L at opposite sides, push upwards, then turn clockwise and drop core free from back plenum.


DA3

SUBMITTAL SHEET



Optional fiberglass insulation on back panel, complies with A.S.T.M. E84 flame and smoke test. (Available only on models with 24" x 24" face)

R4 R6

Round collar up to 14". Standard height is 1", other options available.

2" collar



✓	Model #	Duct Size	Overall Face Dimension "A" x "B"	Depth Of Unit Dimension "C"	Exposed Depth Dimension "D"	Collar Diameter "E"
	DA3 1206	6	11 3/4" x 11 3/4"	1 3/4"	7/16"	5 7/8"
	DA3 1208	8	11 3/4" x 11 3/4"	1 3/4"	7/16"	7 7/8"
	DA3 2406	6	23 3/4" x 23 3/4"	2 7/8"	7/8"	5 7/8"
	DA3 2408	8	23 3/4" x 23 3/4"	2 7/8"	7/8"	7 7/8"
	DA3 2410	10	23 3/4" x 23 3/4"	2 7/8"	7/8"	9 7/8"
	DA3 2412	12	23 3/4" x 23 3/4"	2 7/8"	7/8"	11 7/8"
	DA3 2414	14	23 3/4" x 23 3/4"	2 7/8"	7/8"	13 7/8"

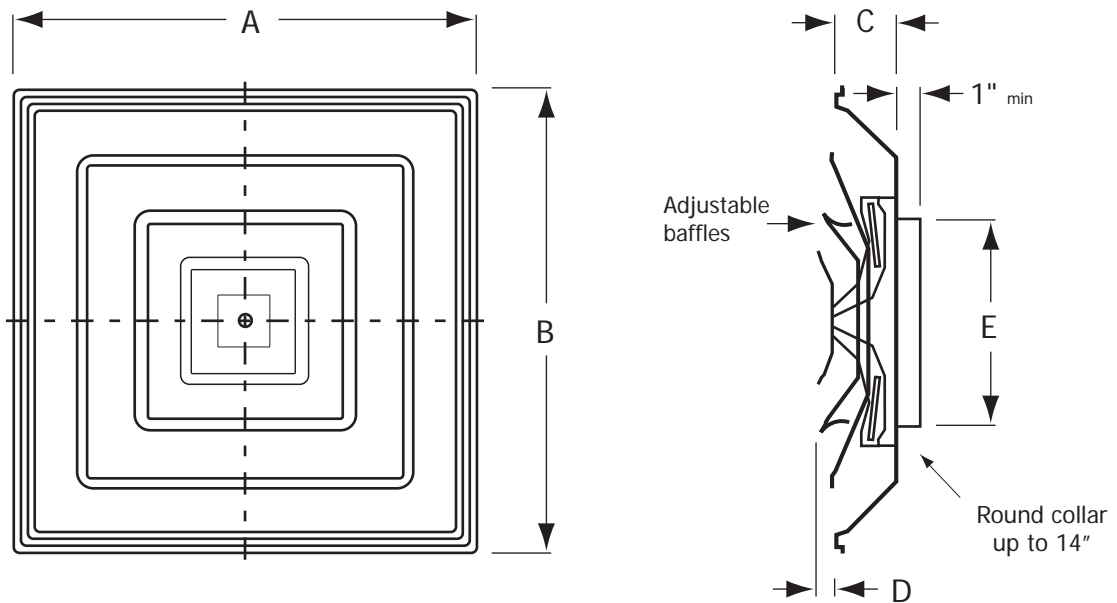
Finish	
<input type="checkbox"/> /W White (Default)	<input type="checkbox"/> /C Custom (Please Specify) _____
Schedule type: _____	
Job: _____	
Architect: _____	
Engineer: _____	
Contractor: _____	

Ceiling Supply Air Diffuser 4 Cone Adjustable

- Material:** Stamped heavy gauge steel.
- Finish:** Powder paint coating - white.
- Air Pattern:** Adjustable horizontal/vertical air pattern
- Mounting:** Surface or lay-in T-bar ceiling.
- Core Removal:** Unlock hanger brackets by swiveling lever down. Holding cone L at opposite sides, push upwards, then turn clockwise and drop core free from back plenum.



DA4



Optional fiberglass insulation on back panel, complies with A.S.T.M. E84 flame and smoke test. (Available only on models with 24" x 24" face)

R4

R6

Round collar up to 14". Standard height is 1", other options available.

2" collar



✓	Model #	Duct Size	Overall Face Dimension "A" x "B"	Depth Of Unit Dimension "C"	Exposed Depth Dimension "D"	Collar Diameter "E"
	DA4 2406	6	23 3/4" x 23 3/4"	2 7/8"	7/8"	5 7/8"
	DA4 2408	8	23 3/4" x 23 3/4"	2 7/8"	7/8"	7 7/8"
	DA4 2410	10	23 3/4" x 23 3/4"	2 7/8"	7/8"	9 7/8"
	DA4 2412	12	23 3/4" x 23 3/4"	2 7/8"	7/8"	11 7/8"
	DA4 2414	14	23 3/4" x 23 3/4"	2 7/8"	7/8"	13 7/8"

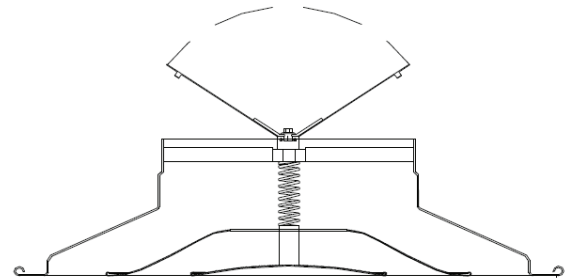
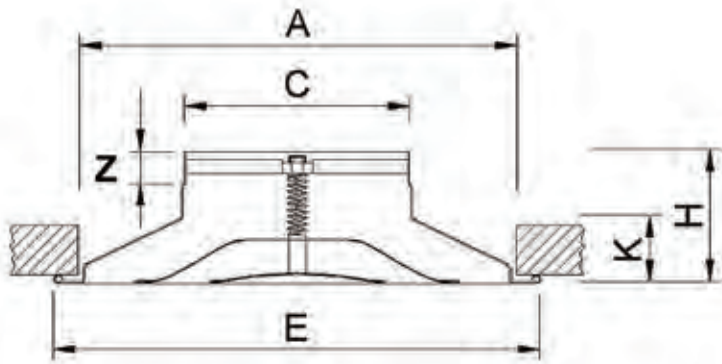
Finish	
<input type="checkbox"/> /W White (default)	<input type="checkbox"/> Custom (please specify)
Schedule type: _____	
Job: _____	
Architect: _____	
Engineer: _____	
Contractor: _____	

High Ceiling Round Diffuser Spun Aluminum Fully Adjustable

- Material:** Heavy gauge spun aluminum.
Finish: Powder paint coating - white.
Air Pattern: 360° diffusion, vertically adjustable.
Mounting: Surface or open ceiling.
Core Adjustment: Rotate the core clockwise or counterclockwise to adjust for horizontal or vertical flow.


DCG

SUBMITTAL SHEET


DCG-R3G

Model	Duct Size	A (in)	C (in)	E (in)	H (in)	K (in)	Z (in)
DCG 06	6"	11 59/64	5 3/4	13 5/16	4 15/16	1 47/64	1
DCG 08	8"	15 5/32	7 3/4	16 47/64	4 17/32	2 9/32	1
DCG 10	10"	18 17/64	9 3/4	19 3/8	4 31/64	2 1/4	1
DCG 12	12"	22 13/64	11 3/4	23 17/64	6 19/32	3 5/32	1
DCG 14	14"	24 13/16	13 29/32	26 1/16	5 33/64	3 17/64	1
DCG 16	16"	24 13/16	15 43/64	26 1/16	5 5/32	2 59/64	1
DCG 18	18"	31 7/32	17 19/32	32 3/4	6 13/16	4 11/64	1
DCG 20	20"	31 7/32	19 9/16	32 3/4	6 27/64	3 13/16	1

Model	Duct Size	A (in)	C (in)	E (in)	H (in)	K (in)	Z (in)
DCG-R3G 08	8"	15 5/32	7 3/4	16 47/64	4 17/32	2 9/32	1
DCG-R3G 10	10"	18 17/64	9 3/4	19 3/8	4 31/64	2 1/4	1
DCG-R3G 14	14"	24 13/16	13 29/32	26 1/16	5 33/64	3 17/64	1
DCG-R3G 16	16"	24 13/16	15 43/64	26 1/16	5 5/32	2 59/64	1
DCG-R3G 18	18"	31 7/32	17 19/32	32 3/4	6 13/16	4 11/64	1
DCG-R3G 20	20"	31 7/32	19 9/16	32 3/4	6 27/64	3 13/16	1

DCG 06 and **DCG 12** can't be supplied with **R3G** but are compatible with **N4** opposed blade dampers and **N5** sliding blade dampers. Dimensions available with **R3G** are **not** compatible with **N4** and **N5** dampers.



Finish	
<input type="checkbox"/> /W White (default)	<input type="checkbox"/> Custom (Please Specify)

Schedule type: _____

Job: _____

Architect: _____

Engineer: _____

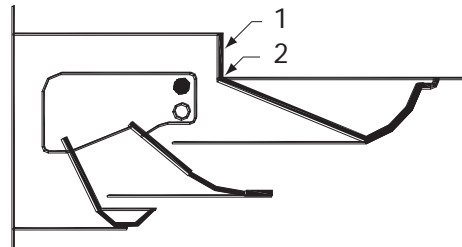
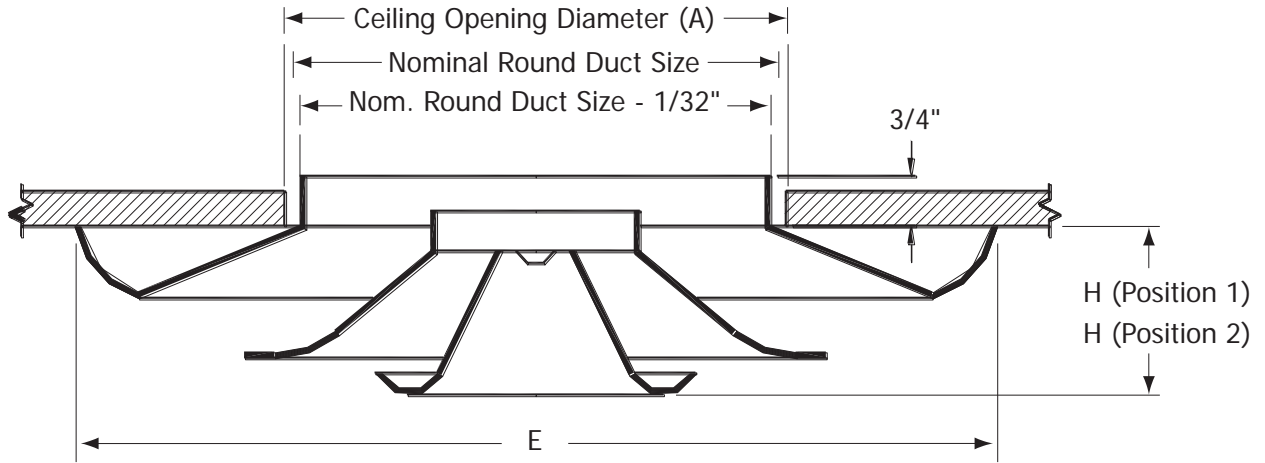
Contractor: _____

High Ceiling Round Diffuser Spun Aluminum, Fully Adjustable

- Material:** Heavy gauge spun aluminum.
- Finish:** Powder paint coating - white.
- Air Pattern:** 360° diffusion, vertically adjustable.
- Mounting:** Surface or open ceiling.



DCR



2-Position Adjustment

✓	Model	Nom. Round Duct Size	A (in)	E (in)	H (Pos. 1)	H (Pos. 2)
	DCR 06	6"	6 1/2"	11 1/8"	1 3/4"	1 1/8"
	DCR 08	8"	8 1/2"	14 3/4"	2 1/8"	1 1/2"
	DCR 10	10"	10 1/2"	18 1/4"	2 7/8"	2 1/8"
	DCR 12	12"	12 1/2"	22"	3 1/8"	2 3/8"
	DCR 14	14"	14 1/2"	26"	3 3/8"	2 5/8"
	DCR 16	16"	16 1/2"	29"	4"	3 1/4"
	DCR 18	18"	18 1/2"	32 1/2"	4 3/4"	3 7/8"
	DCR 20	20"	20 1/2"	36"	5 7/8"	4 7/8"

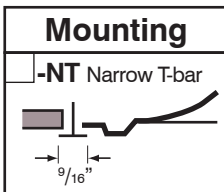
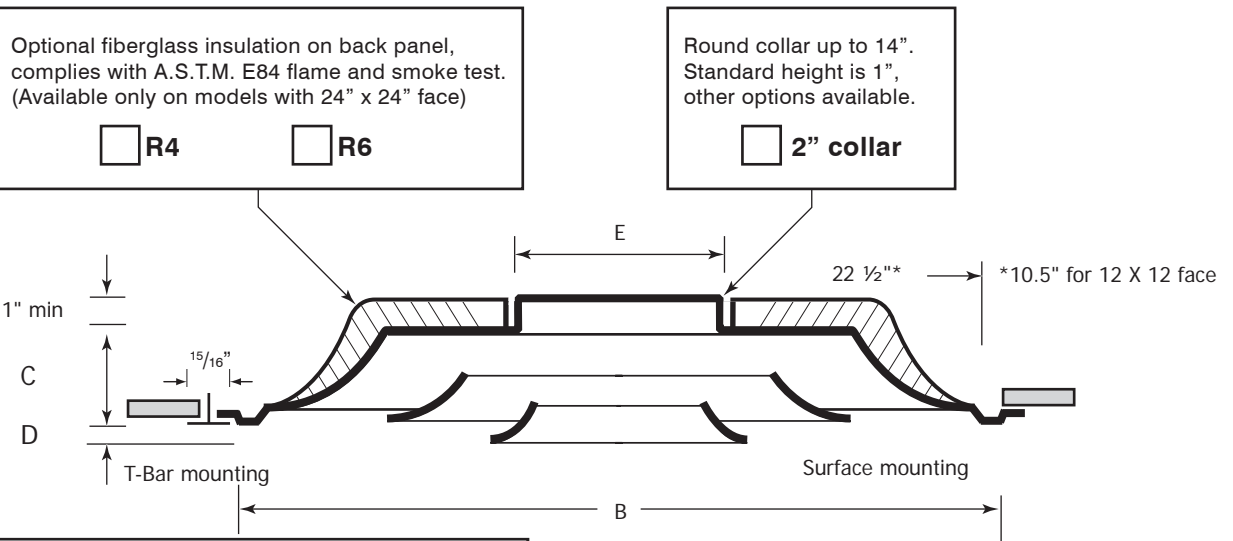
Finish	
<input type="checkbox"/> /W White (default)	<input type="checkbox"/> Custom (please specify) _____



Schedule type: _____
Job: _____
Architect: _____
Engineer: _____
Contractor: _____

Ceiling Square Diffuser - 3 Cone Fixed air pattern

- Material:** Stamped heavy gauge Steel.
Finish: Powder paint coating - white.
Air Pattern: Fixed horizontal 360° diffusion.
Mounting: Surface or Lay-in T-bar ceiling.
Core Removal: Unlock hanger brackets by swiveling lever down. Holding cone L at opposite sides, push upwards, then turn clockwise and drop core free from back plenum.


DF3


Round Collar Baffles

<input type="checkbox"/> W1 1 Way	<input type="checkbox"/> WC 2 Way Corner	<input type="checkbox"/> WO 2 Way Opposed	<input type="checkbox"/> W3 3 Way	<input type="checkbox"/> W4 4 Way (default)

Panel Option for T-bar lay-in Ceiling

<p>No fastening options available</p>	Steel (WxH)	Aluminum (WxH)
	<input type="checkbox"/> -X2412	<input type="checkbox"/> -Y2412
	<input type="checkbox"/> -X2424	<input type="checkbox"/> -Y2424
	<input type="checkbox"/> -X2448	<input type="checkbox"/> -Y2448
	<input type="checkbox"/> -X4824	<input type="checkbox"/> -Y4824
	<input type="checkbox"/> -X2020	<input type="checkbox"/> -Y2020

✓	Model #	Duct Size	E	Face Dim B x B	C	D
	DF3 1206	6	5 7/8"	11 3/4" x 11 3/4"	1 3/4"	7/16"
	DF3 1208	8	7 7/8"	11 3/4" x 11 3/4"	1 3/4"	7/16"
	DF3 2406	6	5 7/8"	23 3/4" x 23 3/4"	2 7/8"	7/8"
	DF3 2408	8	7 7/8"	23 3/4" x 23 3/4"	2 7/8"	7/8"
	DF3 2410	10	9 7/8"	23 3/4" x 23 3/4"	2 7/8"	7/8"
	DF3 2412	12	11 7/8"	23 3/4" x 23 3/4"	2 7/8"	7/8"
	DF3 2414	14	13 7/8"	23 3/4" x 23 3/4"	2 7/8"	7/8"

Finish

/W White (Default) /C Custom (Please Specify)



Equalizing Grid (Option)

Refer to NEG

Damper (Option)

Refer to N4 Refer to N5

Opposed Blade Sliding Blade

Plaster Frame (Option)

Refer to PF

Schedule type: _____

Job: _____

Architect: _____

Engineer: _____

Contractor: _____

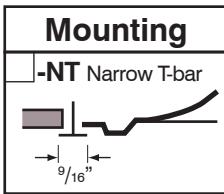
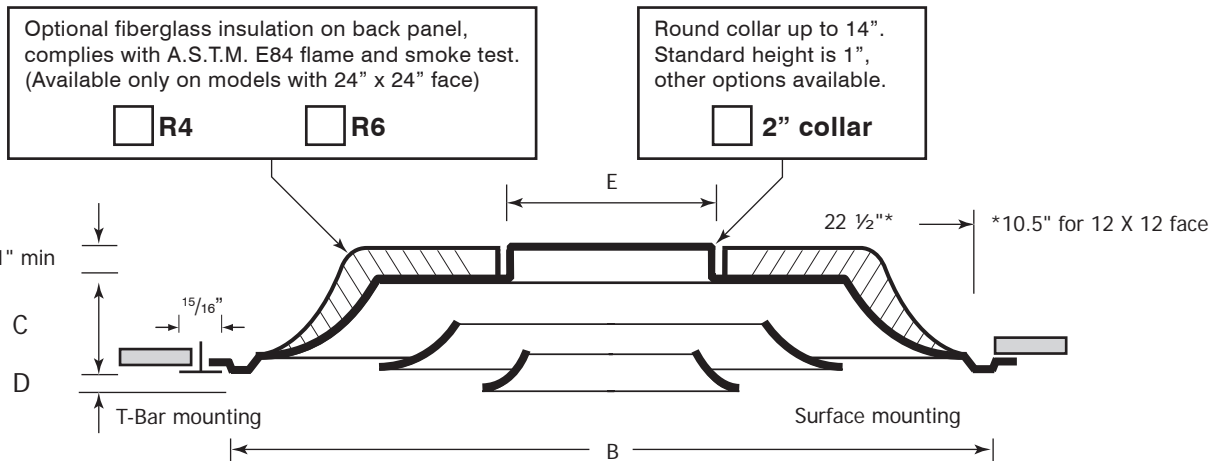
SUBMITTAL SHEET

Ceiling Square Diffuser - 3 Cone Fixed air pattern - 2" Collar

Material: Stamped heavy gauge steel.
Finish: Powder paint coating - white.
Air Pattern: Fixed horizontal 360° diffusion.
Mounting: Surface or Lay-in T-bar ceiling.



DF3D



Round Collar Baffles				
<input type="checkbox"/> W1 1 Way	<input type="checkbox"/> WC 2 Way Corner	<input type="checkbox"/> WO 2 Way Opposed	<input type="checkbox"/> W3 3 Way	<input type="checkbox"/> W4 4 Way (default)

Panel Option for T-bar lay-in Ceiling		
<p>No fastening options available</p>	Steel (WxH)	Aluminum (WxH)
	<input type="checkbox"/> -X2412	<input type="checkbox"/> -Y2412
	<input type="checkbox"/> -X2424	<input type="checkbox"/> -Y2424
	<input type="checkbox"/> -X2448	<input type="checkbox"/> -Y2448
	<input type="checkbox"/> -X4824	<input type="checkbox"/> -Y4824
	<input type="checkbox"/> -X2020	<input type="checkbox"/> -Y2020

✓	Model #	Duct Size	E	Face Dim B x B	C	D
	DF3D 2406	6	5 7/8"	23 3/4" x 23 3/4"	2 7/8"	7/8"
	DF3D 2408	8	7 7/8"	23 3/4" x 23 3/4"	2 7/8"	7/8"
	DF3D 2410	10	9 7/8"	23 3/4" x 23 3/4"	2 7/8"	7/8"
	DF3D 2412	12	11 7/8"	23 3/4" x 23 3/4"	2 7/8"	7/8"

Finish	
<input type="checkbox"/> /W White (Default)	<input type="checkbox"/> /C Custom (Please Specify)



Equalizing Grid (Option) Refer to NEG 	Damper (Option) Refer to N4 Refer to N5 Opposed Blade Sliding Blade	Plaster Frame (Option) Refer to PF
--	---	---

Schedule type: _____

Job: _____

Architect: _____

Engineer: _____

Contractor: _____

Ceiling Square Diffuser - 3 Cone Fixed air pattern

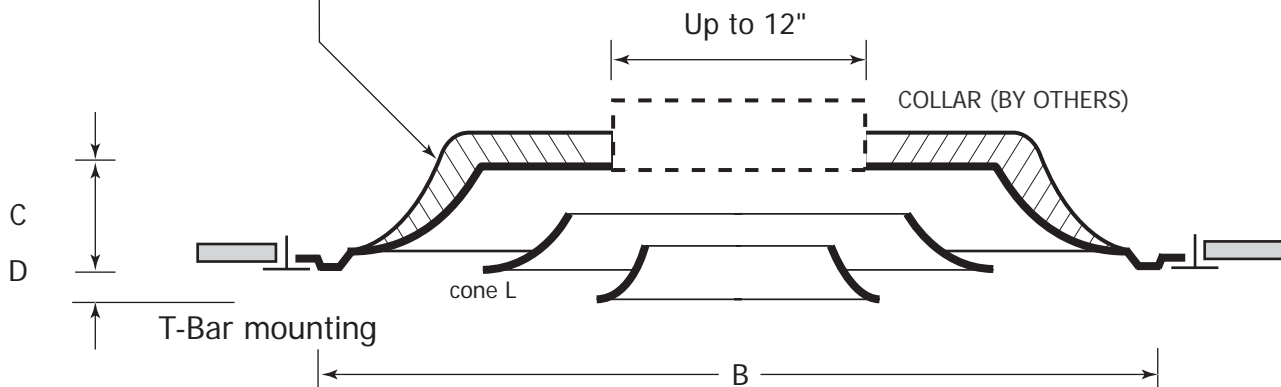
- Material:** Stamped heavy gauge steel.
- Finish:** Powder paint coating - white.
- Air Pattern:** Fixed horizontal 360° diffusion.
- Mounting:** Lay-in T-bar ceiling.
- Core Removal:** Unlock hanger brackets by swiveling lever down. Holding cone L at opposite sides, push upwards, then turn clockwise and drop core free from back plenum.



DF3I

R6 fiberglass back complies with A.S.T.M. E84 flame and smoke test.

Scored for collar sizes up to 12" D. Contractor to install job-specific collar in field. For size 14", please refer to model DF3-R6 2414.



Model #	Face Dim B x B	C	D
DF3I	23 3/4" x 23 3/4"	2 7/8"	7/8"

Finish	
<input type="checkbox"/> /W White (default)	<input type="checkbox"/> Custom (please specify)



Schedule type: _____

Job: _____

Architect: _____

Engineer: _____

Contractor: _____

Ceiling Square Diffuser - 4 Cone Fixed air pattern

- Material:** Stamped heavy gauge Steel.
- Finish:** Powder paint coating - white.
- Air Pattern:** Fixed horizontal 360° diffusion.
- Mounting:** Surface or Lay-in T-bar ceiling.
- Core Removal:** Unlock hanger brackets by swiveling lever down. Holding cone L at opposite sides, push upwards, then turn clockwise and drop core free from back plenum.



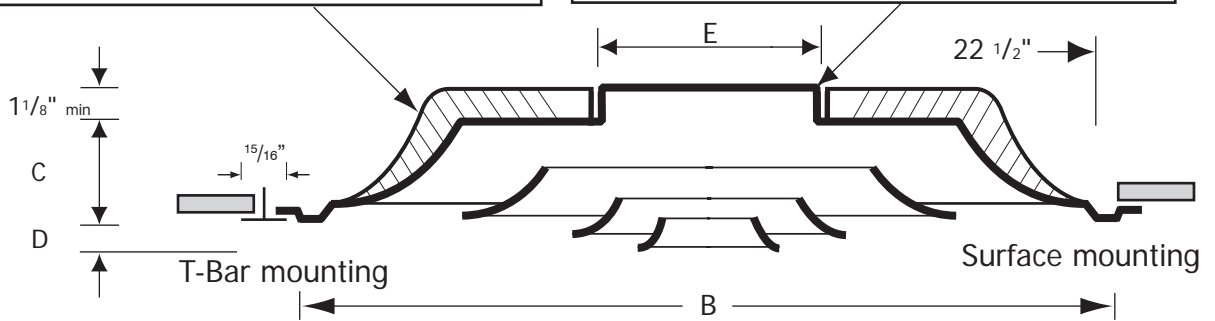
DF4

Optional fiberglass insulation on back panel, complies with A.S.T.M. E84 flame and smoke test. (Available only on models with 24" x 24" face)

- R4 R6

Round collar up to 14". Standard height is 1 1/8", 2" height available.

- 2" collar (specify DF4D)



Mounting (Opt)

-NT Narrow T-bar

Round Collar Baffles

W1 1 Way	WC 2 Way Corner	WO 2 Way Opposed	W3 3 Way	W4 4 Way (default)

Panel Option for T-bar lay-in Ceiling

	Steel (WxH)	Aluminum (WxH)
	<input type="checkbox"/> -X2412	<input type="checkbox"/> -Y2412
	<input type="checkbox"/> -X2424	<input type="checkbox"/> -Y2424
	<input type="checkbox"/> -X2448	<input type="checkbox"/> -Y2448
	<input type="checkbox"/> -X4824	<input type="checkbox"/> -Y4824
	<input type="checkbox"/> -X2020	<input type="checkbox"/> -Y2020

No fastening options available

✓	Model #	Duct Size	E	Face Dim B x B	C	D
	DF4 2406	6	5 7/8"	23 3/4" x 23 3/4"	2 7/8"	7/8"
	DF4 2408	8	7 7/8"	23 3/4" x 23 3/4"	2 7/8"	7/8"
	DF4 2410	10	9 7/8"	23 3/4" x 23 3/4"	2 7/8"	7/8"
	DF4 2412	12	11 7/8"	23 3/4" x 23 3/4"	2 7/8"	7/8"
	DF4 2414	14	13 7/8"	23 3/4" x 23 3/4"	2 7/8"	7/8"

Finish

/W White (Default) /C Custom (Please Specify)



Equalizing Grid (Option)

Refer to NEG

Damper (Option)

Refer to N4 Refer to N5

Opposed Blade Sliding Blade

Plaster Frame (Option)

Refer to PF

Schedule type: _____

Job: _____

Architect: _____

Engineer: _____

Contractor: _____

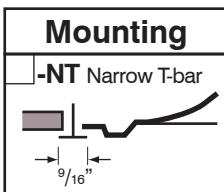
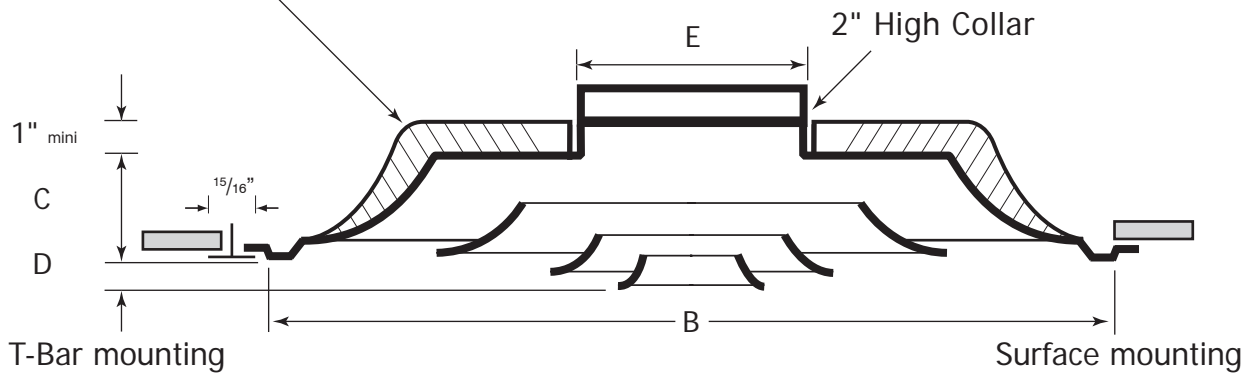
Ceiling Square Diffuser - 4 Cone Fixed air pattern - 2" High Collar

Material: Stamped heavy gauge steel.
Finish: Powder paint coating - white.
Air Pattern: Fixed horizontal 360° diffusion.
Mounting: Surface or Lay-in T-bar ceiling.


DF4D

Optional fiberglass insulation on back panel, complies with A.S.T.M. E84 flame and smoke test.

R4 R6



Round Collar Baffles

<input type="checkbox"/> W1 1 Way	<input type="checkbox"/> WC	<input type="checkbox"/> WO	<input type="checkbox"/> W3 3 Way	<input type="checkbox"/> W4 4 Way (default)

Panel Option for T-bar lay-in Ceiling

<p>No fastening options available</p>	Steel (WxH)	Aluminum (WxH)
	<input type="checkbox"/> -X2412	<input type="checkbox"/> -Y2412
	<input type="checkbox"/> -X2424	<input type="checkbox"/> -Y2424
	<input type="checkbox"/> -X2448	<input type="checkbox"/> -Y2448
	<input type="checkbox"/> -X4824	<input type="checkbox"/> -Y4824
	<input type="checkbox"/> -X2020	<input type="checkbox"/> -Y2020

<input checked="" type="checkbox"/>	Model #	Duct Size	E	Face Dim B x B	C	D
	DF4D 2406	6	5 7/8"	23 3/4" x 23 3/4"	2 7/8"	7/8"
	DF4D 2408	8	7 7/8"	23 3/4" x 23 3/4"	2 7/8"	7/8"
	DF4D 2410	10	9 7/8"	23 3/4" x 23 3/4"	2 7/8"	7/8"
	DF4D 2412	12	11 7/8"	23 3/4" x 23 3/4"	2 7/8"	7/8"

Finish

/W White (Default) /C Custom (Please Specify)



Equalizing Grid (Option) Refer to NEG 	Damper (Option) Refer to N4 Refer to N5 Opposed Blade Sliding Blade	Plaster Frame (Option) Refer to PF
--	---	---

Schedule type: _____
 Job: _____
 Architect: _____
 Engineer: _____
 Contractor: _____

Ceiling Square Diffuser - 4 Cone Fixed air pattern

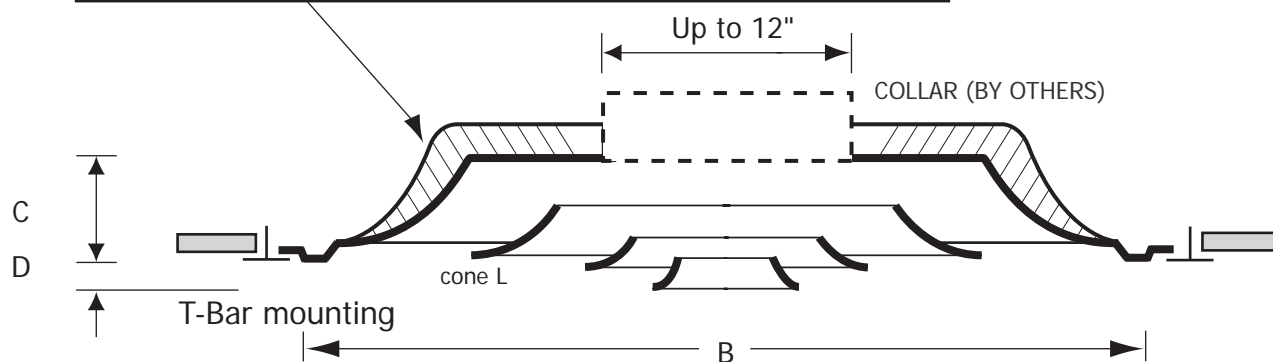
- Material:** Stamped heavy gauge steel.
- Finish:** Powder paint coating - white.
- Air Pattern:** Fixed horizontal 360° diffusion.
- Mounting:** Lay-in T-bar ceiling.
- Core Removal:** Unlock hanger brackets by swiveling lever down. Holding cone L at opposite sides, push upwards, then turn clockwise and drop core free from back plenum.



DF4I

R6 fiberglass back complies with A.S.T.M. E84 flame and smoke test.

Scored for collar sizes up to 12" D. Contractor to install job-specific collar in field. For size 14", please refer to model DF4-R6 2414.



Model #	Face Dim B x B	C	D
DF4I	23 3/4" x 23 3/4"	2 7/8"	7/8"

Finish	
<input type="checkbox"/> /W White (default)	<input type="checkbox"/> Custom (please specify)



Schedule type: _____

Job: _____

Architect: _____

Engineer: _____

Contractor: _____

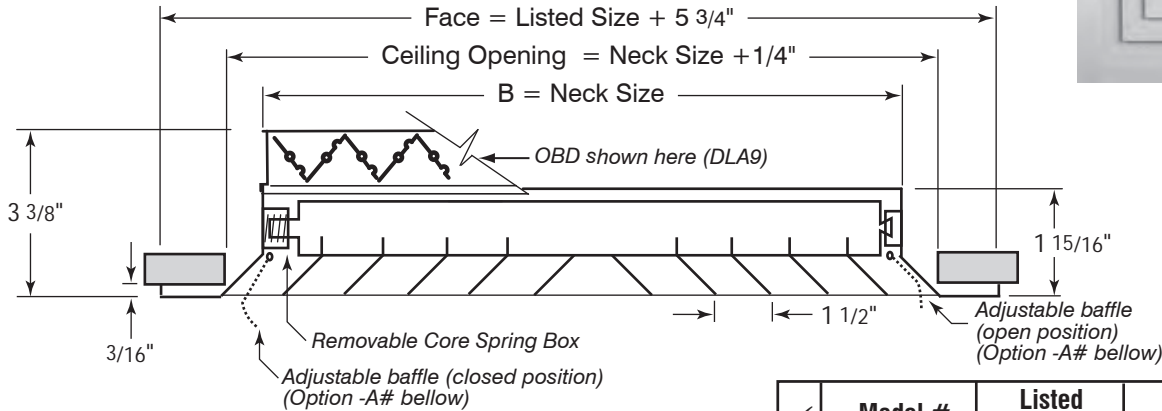
Ceiling Diffuser - Aluminum Louvered Face Directional Fixed Air Pattern - Square Neck

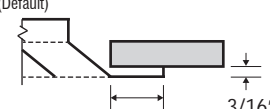

Material: Heavy gauge aluminum.
Finish: Powder paint coating - white.
Mounting: Surface or Lay-in T-bar ceiling.
Volume Control: Available with pre-installed aluminum OBD (Model# DLA9).

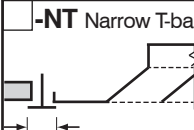
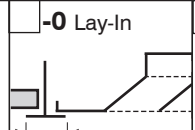
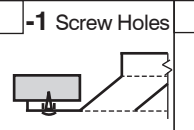
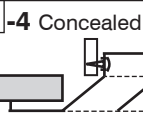


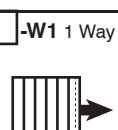
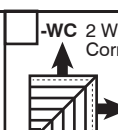
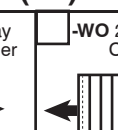
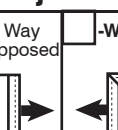
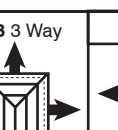
DLA

SUBMITTAL SHEET

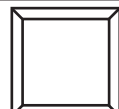

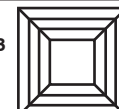



Border Type	
<input type="checkbox"/> -F Flat Frame (Default) 	<input type="checkbox"/> -B Beveled Frame 

Mounting			
<input type="checkbox"/> -NT Narrow T-bar 	<input type="checkbox"/> -O Lay-In 	<input type="checkbox"/> -1 Screw Holes 	<input type="checkbox"/> -4 Concealed 

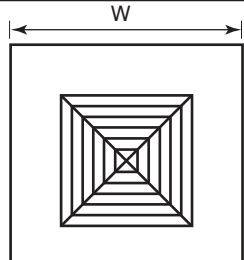
Core Selection (-W) & Adjustable Baffles (-A)				
<input type="checkbox"/> -W1 1 Way 	<input type="checkbox"/> -WC 2 Way Corner 	<input type="checkbox"/> -WO 2 Way Opposed 	<input type="checkbox"/> -W3 3 Way 	<input type="checkbox"/> -W4 4 Way (Default) 
<input type="checkbox"/> -A1 shown here in dotted line	<input type="checkbox"/> -AC shown here in dotted line	<input type="checkbox"/> -A0 shown here in dotted line	<input type="checkbox"/> -A3 shown here in dotted line	<input type="checkbox"/> -A4 shown here in dotted line

<input checked="" type="checkbox"/>	Model #	Listed Size	Neck Size B	Face Size
	DLA 0606	6" x 6"	5 15/16" x 5 15/16"	11 3/4" x 11 3/4"
	DLA 0909	9" x 9"	8 15/16" x 8 15/16"	14 3/4" x 14 3/4"
	DLA 1212	12" x 12"	11 15/16" x 11 15/16"	17 3/4" x 17 3/4"
	DLA 1515	15" x 15"	14 15/16" x 14 15/16"	20 3/4" x 20 3/4"
	DLA 1818	18" x 18"	17 15/16" x 17 15/16"	23 3/4" x 23 3/4"
	DLA9 0606	6" x 6"	6 3/16" x 6 3/16"	11 3/4" x 11 3/4"
	DLA9 0909	9" x 9"	9 3/16" x 9 3/16"	14 3/4" x 14 3/4"
	DLA9 1212	12" x 12"	12 3/16" x 12 3/16"	17 3/4" x 17 3/4"
	DLA9 1515	15" x 15"	14 3/16" x 14 3/16"	20 3/4" x 20 3/4"
	DLA9 1818	18" x 18"	17 3/16" x 17 3/16"	23 3/4" x 23 3/4"

Plaque options Only with -W4			
<input type="checkbox"/> -PQ1 	<input type="checkbox"/> -PQ2 	<input type="checkbox"/> -PQ3 	<input type="checkbox"/> -PQ4 

Finish	
<input type="checkbox"/> /W White (Default)	<input type="checkbox"/> /C Custom (Please Specify)



Panel Option for T-bar lay-in Ceiling		
	Steel (WxH)	Aluminum (WxH)
	<input type="checkbox"/> -X2412	<input type="checkbox"/> -Y2412
	<input type="checkbox"/> -X2424	<input type="checkbox"/> -Y2424
	<input type="checkbox"/> -X4812	<input type="checkbox"/> -Y4812
	<input type="checkbox"/> -X4824	<input type="checkbox"/> -Y4824

No mounting options available

Schedule type: _____
 Job: _____
 Architect: _____
 Engineer: _____
 Contractor: _____

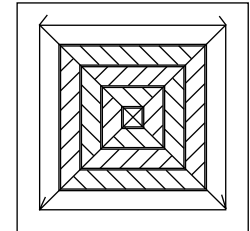
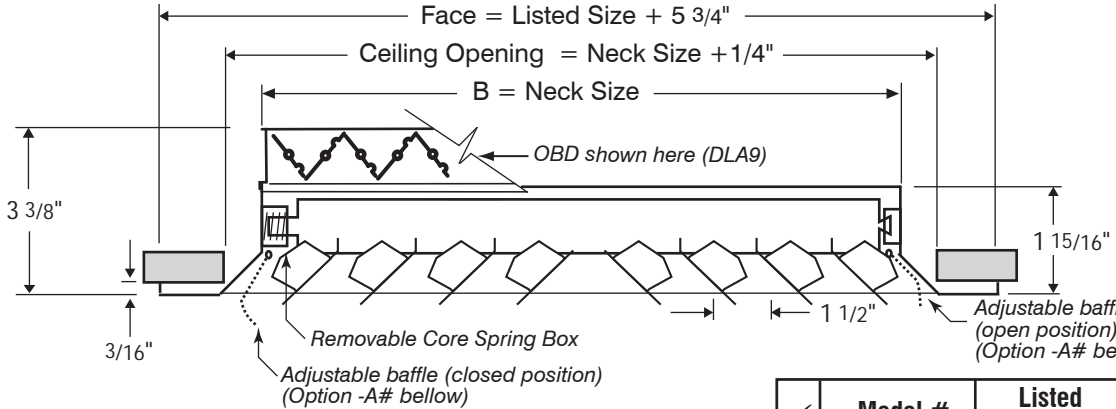
SUBMITTAL SHEET

Ceiling Diffuser - Aluminum Louvered Face Directional Fixed Air Pattern - Square Neck

- Material:** Heavy gauge aluminum.
- Finish:** Powder paint coating - white.
- Mounting:** Surface or Lay-in T-bar ceiling.
- Volume Control:** Available with pre-installed aluminum OBD (Model# DLA9-HI).



DLA-HI



High Induction Vanes
(Option -A# below)

Border Type

-F Flat Frame (Default)	-B Beveled Frame

Mounting

-NT Narrow T-bar	-O Lay-In	-1 Screw Holes	-4 Concealed

Core Selection (-W) & Adjustable Baffles (-A)

-W1 1 Way	-WC 2 Way Corner	-WO 2 Way Opposed	-W3 3 Way	-W4 4 Way (Default)
-A1 shown here in dotted line	-AC shown here in dotted line	-A0 shown here in dotted line	-A3 shown here in dotted line	-A4 shown here in dotted line

Panel Option for T-bar lay-in Ceiling

	Steel (WxH)	Aluminum (WxH)
	<input type="checkbox"/> -X2412	<input type="checkbox"/> -Y2412
	<input type="checkbox"/> -X2424	<input type="checkbox"/> -Y2424
	<input type="checkbox"/> -X4812	<input type="checkbox"/> -Y4812
	<input type="checkbox"/> -X4824	<input type="checkbox"/> -Y4824

No mounting options available

✓	Model #	Listed Size	Neck Size B	Face Size
	DLA 0606	6" x 6"	5 15/16" x 5 15/16"	11 3/4" x 11 3/4"
	DLA 0909	9" x 9"	8 15/16" x 8 15/16"	14 3/4" x 14 3/4"
	DLA 1212	12" x 12"	11 15/16" x 11 15/16"	17 3/4" x 17 3/4"
	DLA 1515	15" x 15"	14 15/16" x 14 15/16"	20 3/4" x 20 3/4"
	DLA 1818	18" x 18"	17 15/16" x 17 15/16"	23 3/4" x 23 3/4"
	DLA9 0606	6" x 6"	6 3/16" x 6 3/16"	11 3/4" x 11 3/4"
	DLA9 0909	9" x 9"	9 3/16" x 9 3/16"	14 3/4" x 14 3/4"
	DLA9 1212	12" x 12"	12 3/16" x 12 3/16"	17 3/4" x 17 3/4"
	DLA9 1515	15" x 15"	14 3/16" x 14 3/16"	20 3/4" x 20 3/4"
	DLA9 1818	18" x 18"	17 3/16" x 17 3/16"	23 3/4" x 23 3/4"

Plaque options Only with -W4

-PQ1	-PQ2	-PQ3	-PQ4

Finish

<input type="checkbox"/> /W White (Default)	<input type="checkbox"/> /C Custom (Please Specify)
---	---



Schedule type: _____

Job: _____

Architect: _____

Engineer: _____

Contractor: _____

Ceiling Diffuser - Aluminum Louvered Face Directional Fixed Air Pattern, Insulated Back

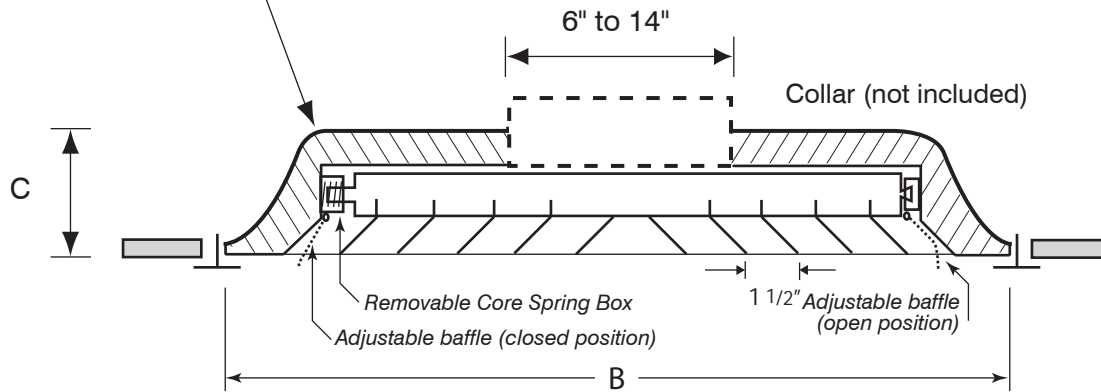
Material: Heavy gauge aluminum and molded fiberglass.
Finish: Powder paint coating - white.
Mounting: Lay-in T-bar ceiling.



DLAI

R6 fiberglass back complies with A.S.T.M. E84 flame and smoke test.

Scored for collar sizes up to 14" D.
Contractor to install job-specific collar in field.



Model #	Face Dim B x B	C
DLAI	23 3/4" x 23 3/4"	3 7/8"

Core Selection (-W) & Adjustable Baffles (-A)				
<input type="checkbox"/> -W1 1 Way	<input type="checkbox"/> -WC 2 Way Corner	<input type="checkbox"/> -WO 2 Way Opposed	<input type="checkbox"/> -W3 3 Way	<input type="checkbox"/> -W4 4 Way (Default)
<input type="checkbox"/> -A1 shown here in dotted line	<input type="checkbox"/> -AC shown here in dotted line	<input type="checkbox"/> -AO shown here in dotted line	<input type="checkbox"/> -A3 shown here in dotted line	<input type="checkbox"/> -A4 shown here in dotted line
Finish				
<input type="checkbox"/> /W White (Default)	<input type="checkbox"/> /C Custom (Please Specify)			



Schedule type: _____

Job: _____

Architect: _____

Engineer: _____

Contractor: _____

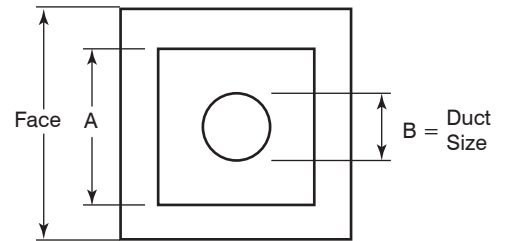
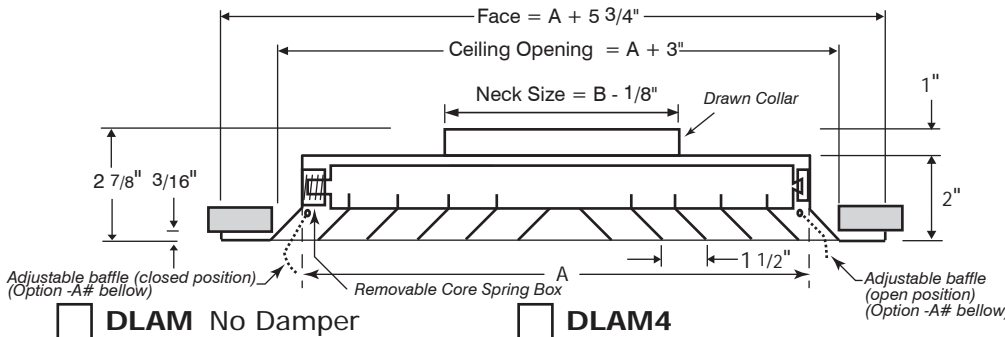
SUBMITTAL SHEET

Ceiling Diffuser - Aluminum Louvered Face Directional Fixed Air Pattern, Round Neck

Material: Heavy gauge aluminum.
Finish: Powder paint coating - white.
Mounting: Surface or Lay-in T-bar ceiling.
Volume Control: Available with pre-installed opposed blade damper (Model# DLAM4) or radial sliding blade damper (Model# DLAM5).



DLAM



DLAM No Damper

DLAM4

DLAM5 Pre-Installed N5 Radial Sliding Blade Damper

Border Type

-F Flat Frame (Default) **-B Beveled Frame**

Mounting

-NT Narrow T-bar **-O Lay-In** **-1 Screw Holes** **-4 Concealed**

Core Selection (-W) & Adjustable Baffles (-A)

-W1 1 Way **-WC 2 Way Corner** **-WO 2 Way Opposed** **-W3 3 Way** **-W4 4 Way (Default)**

-A1 shown here in dotted line **-AC** shown here in dotted line **-AO** shown here in dotted line **-A3** shown here in dotted line **-A4** shown here in dotted line

Finish

/W White (Default) **/C Custom (Please Specify)**



Panel Option for T-bar lay-in Ceiling

Steel (WxH) Aluminum (WxH)

-X1224 **-Y1224**

-X2412 **-Y2412**

-X2424 **-Y2424**

-X2448 **-Y2448**

-X4824 **-Y4824**

-X2020 **-Y2020**

No fastening options available

✓	Model #	A	B	Neck Size	Face Size
	0606 06	6 x 6	6	5 7/8	11 3/4 x 11 3/4
	0909 06	9 x 9	6	5 7/8	14 3/4 x 14 3/4
	0909 08	9 x 9	8	7 7/8	14 3/4 x 14 3/4
	1212 06	12 x 12	6	5 7/8	17 3/4 x 17 3/4
	1212 08	12 x 12	8	7 7/8	17 3/4 x 17 3/4
	1212 10	12 x 12	10	9 7/8	17 3/4 x 17 3/4
	1212 12	12 x 12	12	11 7/8	17 3/4 x 17 3/4
	1515 06	15 x 15	6	5 7/8	20 3/4 x 20 3/4
	1515 08	15 x 15	8	7 7/8	20 3/4 x 20 3/4
	1515 10	15 x 15	10	9 7/8	20 3/4 x 20 3/4
	1515 12	15 x 15	12	11 7/8	20 3/4 x 20 3/4
	1515 14 ¹	15 x 15	14	13 7/8	20 3/4 x 20 3/4
	1818 06	18 x 18	6	5 7/8	23 3/4 x 23 3/4
	1818 08	18 x 18	8	7 7/8	23 3/4 x 23 3/4
	1818 10	18 x 18	10	9 7/8	23 3/4 x 23 3/4
	1818 12	18 x 18	12	11 7/8	23 3/4 x 23 3/4
	1818 14 ¹	18 x 18	14	13 7/8	23 3/4 x 23 3/4
	1818 16 ²	18 x 18	16	15 7/8	23 3/4 x 23 3/4

¹ Size not available for DLAM5 ² Size not available for DLAM4 and DLAM5

Schedule type: _____

Job: _____

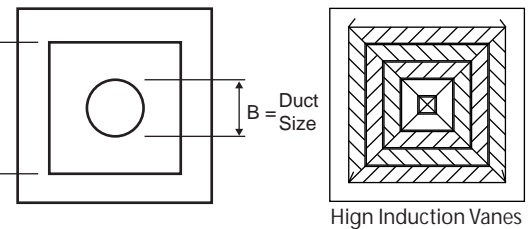
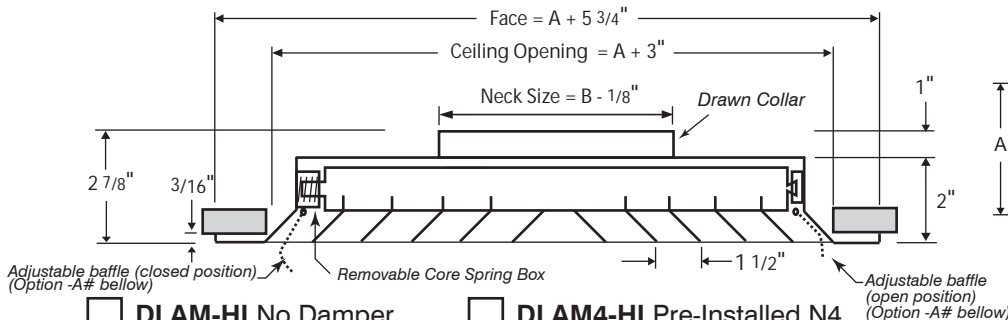
Architect: _____

Engineer: _____

Contractor: _____

Ceiling Diffuser - Aluminum Louvered Face Directional Fixed Air Pattern, Round Neck

Material: Heavy gauge aluminum.
Finish: Powder paint coating - white.
Mounting: Surface or Lay-in T-bar ceiling.
Volume Control: Available with pre-installed opposed blade damper (Model# DLAM4-HI) or radial sliding blade damper (Model# DLAM5-HI).


DLAM


- DLAM-HI** No Damper
 DLAM4-HI Pre-Installed N4 Opposed Blade Damper
 DLAM5 Pre-Installed N5 Radial Sliding Blade Damper

Border Type

-F Flat Frame (Default)
 -B Beveled Frame

Mounting

-NT Narrow T-bar
 -O Lay-In
 -1 Screw Holes
 -4 Concealed

Core Selection (-W) & Adjustable Baffles (-A)

-W1 1 Way
 -WC 2 Way Corner
 -WO 2 Way Opposed
 -W3 3 Way
 -W4 4 Way (Default)

-A1 shown here in dotted line
 -AC shown here in dotted line
 -AO shown here in dotted line
 -A3 shown here in dotted line
 -A4 shown here in dotted line

Finish

/W White (Default)
 /C Custom (Please Specify)

Panel Option for T-bar lay-in Ceiling

	Steel (WxH)	Aluminum (WxH)
	<input type="checkbox"/> -X1224	<input type="checkbox"/> -Y1224
	<input type="checkbox"/> -X2412	<input type="checkbox"/> -Y2412
	<input type="checkbox"/> -X2424	<input type="checkbox"/> -Y2424
	<input type="checkbox"/> -X2448	<input type="checkbox"/> -Y2448
	<input type="checkbox"/> -X4824	<input type="checkbox"/> -Y4824
	<input type="checkbox"/> -X2020	<input type="checkbox"/> -Y2020

No fastening options available

✓	Model #	A	B	Neck Size	Face Size
	0606 06	6 x 6	6	5 7/8	11 3/4 x 11 3/4
	0909 06	9 x 9	6	5 7/8	14 3/4 x 14 3/4
	0909 08	9 x 9	8	7 7/8	14 3/4 x 14 3/4
	1212 06	12 x 12	6	5 7/8	17 3/4 x 17 3/4
	1212 08	12 x 12	8	7 7/8	17 3/4 x 17 3/4
	1212 10	12 x 12	10	9 7/8	17 3/4 x 17 3/4
	1212 12	12 x 12	12	11 7/8	17 3/4 x 17 3/4
	1515 06	15 x 15	6	5 7/8	20 3/4 x 20 3/4
	1515 08	15 x 15	8	7 7/8	20 3/4 x 20 3/4
	1515 10	15 x 15	10	9 7/8	20 3/4 x 20 3/4
	1515 12	15 x 15	12	11 7/8	20 3/4 x 20 3/4
	1515 14 ¹	15 x 15	14	13 7/8	20 3/4 x 20 3/4
	1818 06	18 x 18	6	5 7/8	23 3/4 x 23 3/4
	1818 08	18 x 18	8	7 7/8	23 3/4 x 23 3/4
	1818 10	18 x 18	10	9 7/8	23 3/4 x 23 3/4
	1818 12	18 x 18	12	11 7/8	23 3/4 x 23 3/4
	1818 14 ¹	18 x 18	14	13 7/8	23 3/4 x 23 3/4
	1818 16 ²	18 x 18	16	15 7/8	23 3/4 x 23 3/4

¹ Size not available for DLAM5 ² Size not available for DLAM4 and DLAM5

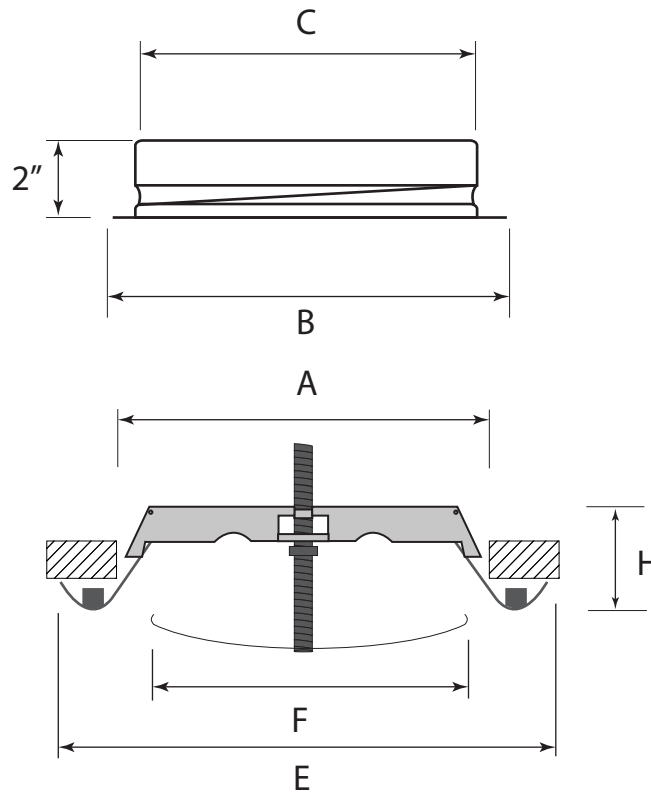
Schedule type: _____
 Job: _____
 Architect: _____
 Engineer: _____
 Contractor: _____

Mini Valve Diffuser Pressed steel, Adjustable core

- Material:** Powder coated heavy gauge steel.
Galvanized steel mounting.
- Finish:** Powder paint coating - white.
- Air Pattern:** 360° diffusion, vertically adjustable.
- Mounting:** Surface or open ceiling.
- Core Adjustment:** Rotate the core clockwise or counterclockwise to adjust flow.



DRV



Finish	
<input type="checkbox"/> /W White (default)	<input type="checkbox"/> Custom (please specify) _____



Model	Duct Size	A	F	H	C	B	E
DRV 04	4"	4.09"	2.95"	1.57"	3.9"	4.92"	5.39"
DRV 05	5"	5.08"	3.9"	1.81"	4.88"	5.91"	6.46"
DRV 06	6"	6.65"	5.08"	2.13"	5.9"	6.91"	7.75"
DRV 08	8"	8.23"	6.18"	2.48"	7.83"	8.85"	9.76"

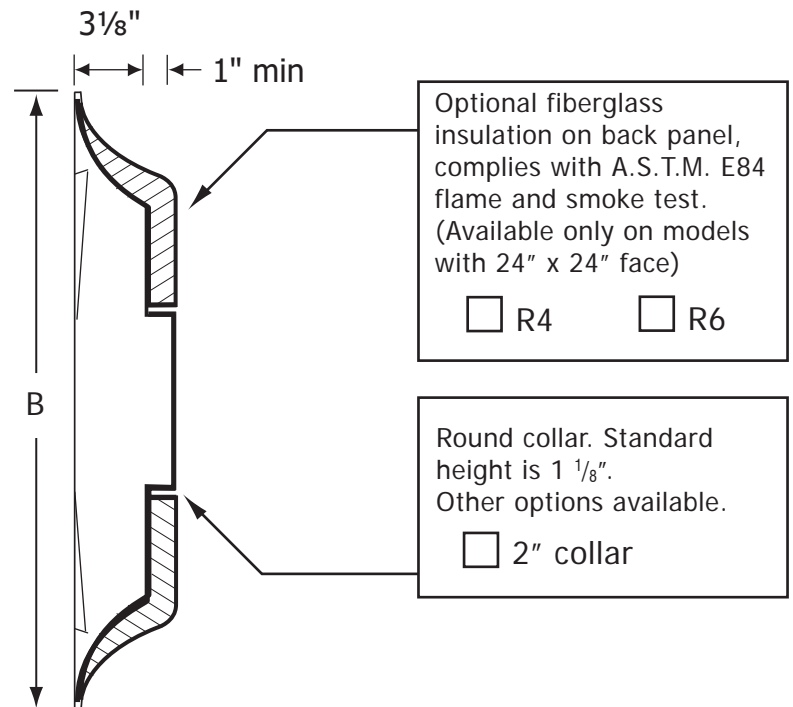
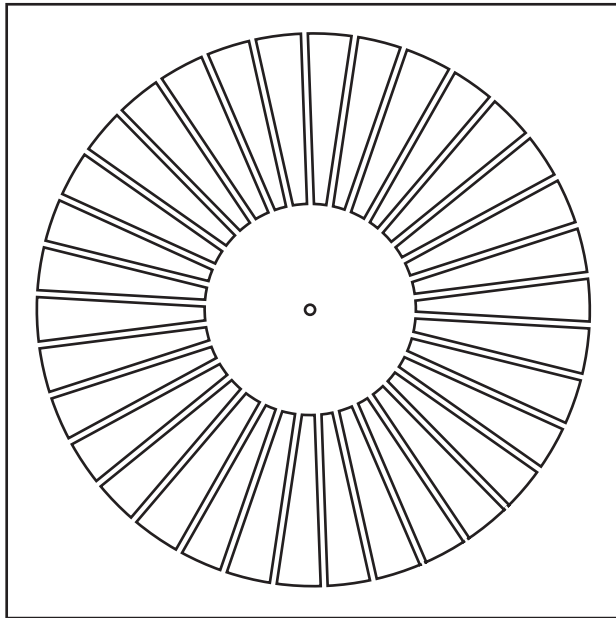
Schedule type: _____
Job: _____
Architect: _____
Engineer: _____
Contractor: _____

Swirl Face Supply Diffuser Fixed face

- Material:** Stamped heavy gauge steel
Finish: Powder paint coating - white
Air Pattern: Fixed 360° spiral pattern
Mounting: Lay-in T-bar ceiling



DSW



✓	Model #	Duct Size	Neck Size	Face Dim B x B
	DSW 2406	6	5 7/8"	23 7/8" x 23 7/8"
	DSW 2408	8	7 7/8"	23 7/8" x 23 7/8"
	DSW 2410	10	9 7/8"	23 7/8" x 23 7/8"
	DSW 2412	12	11 7/8"	23 7/8" x 23 7/8"
	DSW 2414	14	13 7/8"	23 7/8" x 23 7/8"

Finish	
<input type="checkbox"/> /W White (default)	<input type="checkbox"/> Custom (please specify)



Schedule type: _____

Job: _____

Architect: _____

Engineer: _____

Contractor: _____

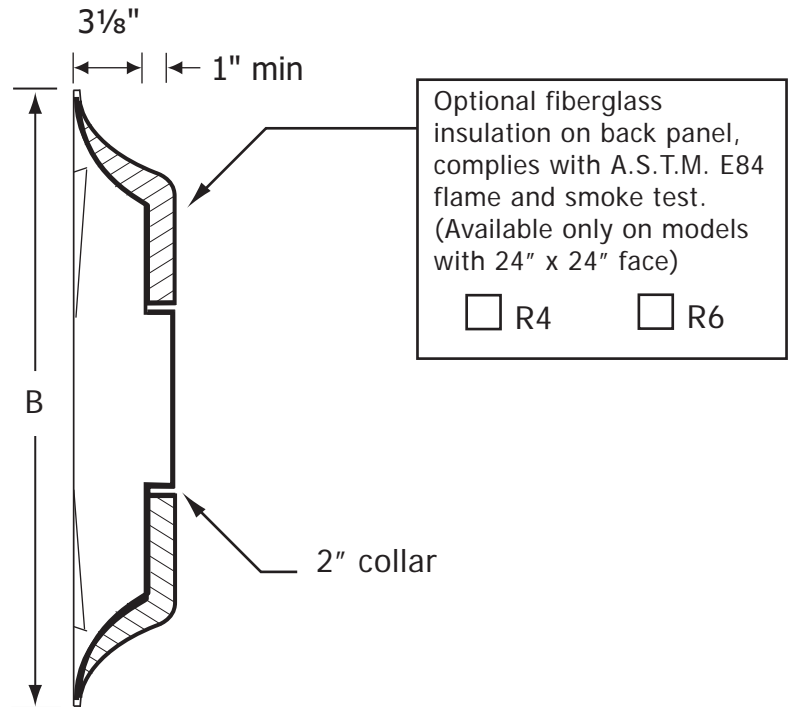
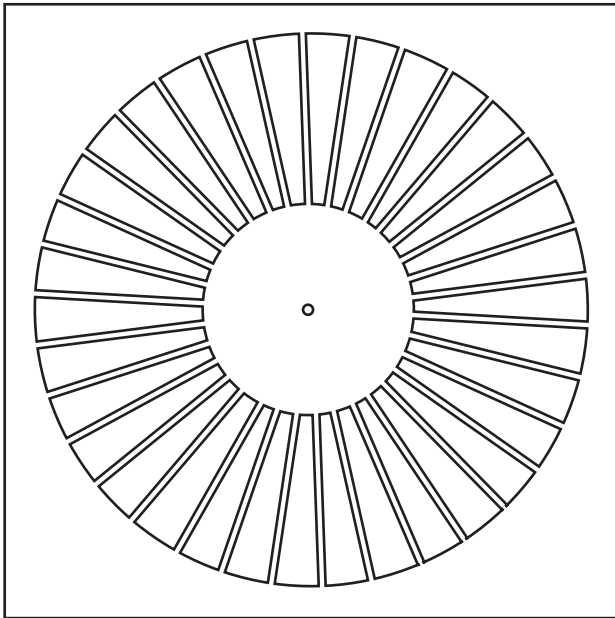
SUBMITTAL SHEET

Swirl Face Supply Diffuser Fixed face - 2" Collar

- Material:** Stamped heavy gauge steel
Finish: Powder paint coating - white
Air Pattern: Fixed 360° spiral pattern
Mounting: Lay-in T-bar ceiling



DSWD



✓	Model #	Duct Size	Neck Size	Face Dim B x B
	DSWD 2406	6	5 7/8"	23 7/8" x 23 7/8"
	DSWD 2408	8	7 7/8"	23 7/8" x 23 7/8"
	DSWD 2410	10	9 7/8"	23 7/8" x 23 7/8"
	DSWD 2412	12	11 7/8"	23 7/8" x 23 7/8"
	DSWD 2414	14	13 7/8"	23 7/8" x 23 7/8"

Finish	
<input type="checkbox"/> /W White (default)	<input type="checkbox"/> Custom (please specify)



Schedule type: _____

Job: _____

Architect: _____

Engineer: _____

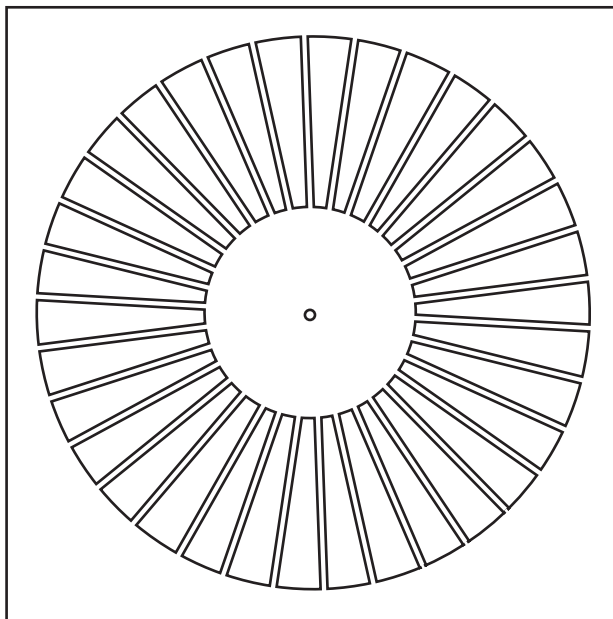
Contractor: _____

Swirl Face Supply Diffuser Fixed face

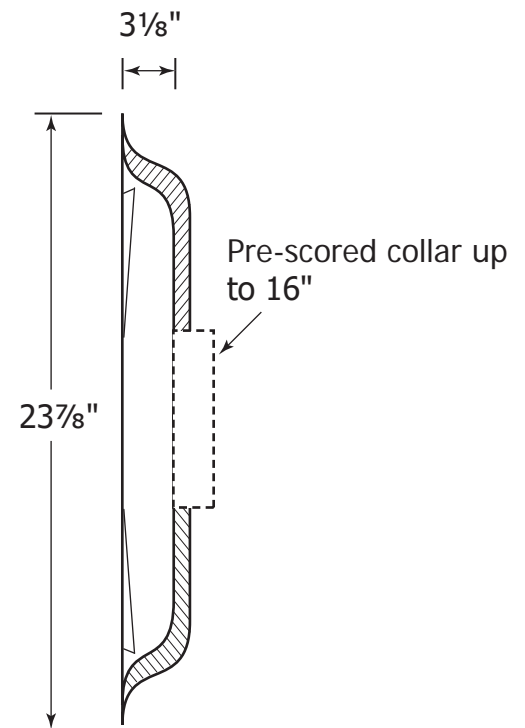
- Material:** Stamped heavy gauge steel back panel.
Finish: Powder paint coating - white.
Air Pattern: Fixed 360° spiral pattern.
Mounting: Lay-in T-bar ceiling.
Insulation: R6 Molded Fiberglass.



Fiberglass back complies with A.S.T.M. E84 flame and smoke test. Scored for collar sizes up to 14" D.



DSWI



Finish	
<input type="checkbox"/> /W White (default)	<input type="checkbox"/> Custom (please specify)



Schedule type: _____

Job: _____

Architect: _____

Engineer: _____

Contractor: _____

SUBMITTAL SHEET

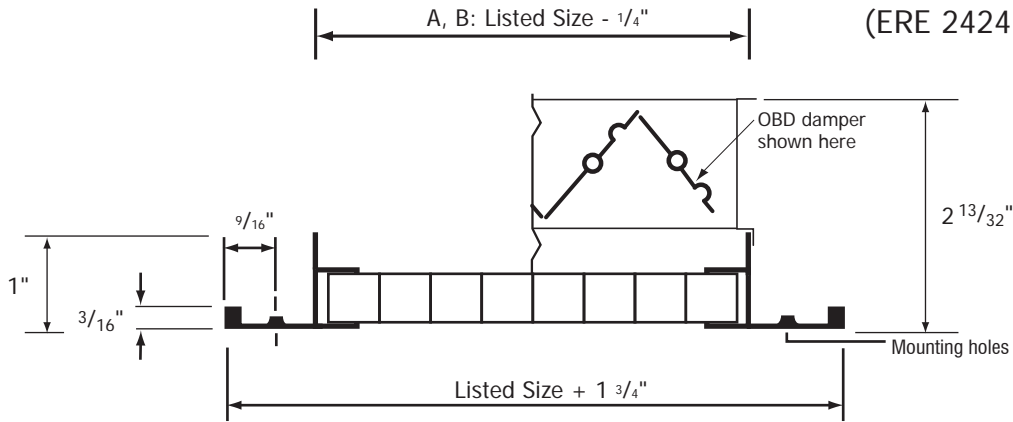
Eggcrate Return Grille for Surface Mount



- Material:** All aluminium construction.
Mounting: Drywall or any surface mounting.
 Countersunk mounting holes on frame.
Grid core: Aluminum 1/2" x 1/2" x 1/2".

- ERE** (without OBD damper) **ERE7** (with OBD damper)

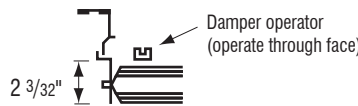
ERE / ERE7
 (ERE 2424 shown here)



Size limits	Width A		Height B	
	in	mm	in	mm
Minimum	4	102	4	102
Maximum	48	1219	48	1219

#7 STEEL DAMPER FURNISHED ON LISTED WIDTHS OF 4" AND OVER (for 1" increments only)

#9 STEEL DAMPER FURNISHED ON LISTED WIDTHS UNDER 4"



Options	
<input type="checkbox"/> -GK	<input type="checkbox"/> -GN
Flange Gasket	Neck Gasket

Panel Option for T-bar lay-in Ceiling

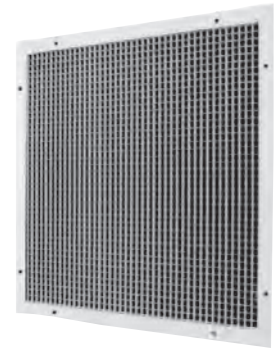
	Steel (WxH)	Aluminum (WxH)
	<input type="checkbox"/> -X1212	<input type="checkbox"/> -Y1212
	<input type="checkbox"/> -X1224	<input type="checkbox"/> -Y1224
	<input type="checkbox"/> -X2412	<input type="checkbox"/> -Y2412
	<input type="checkbox"/> -X2424	<input type="checkbox"/> -Y2424
	<input type="checkbox"/> -X2448	<input type="checkbox"/> -Y2448
	<input type="checkbox"/> -X4824	<input type="checkbox"/> -Y4824
	<input type="checkbox"/> -X2020	<input type="checkbox"/> -Y2020

No fastening options available

Finish	
<input type="checkbox"/> /W White (default)	<input type="checkbox"/> Custom _____ (please specify)

Schedule type: _____
 Job: _____
 Architect: _____
 Engineer: _____
 Contractor: _____

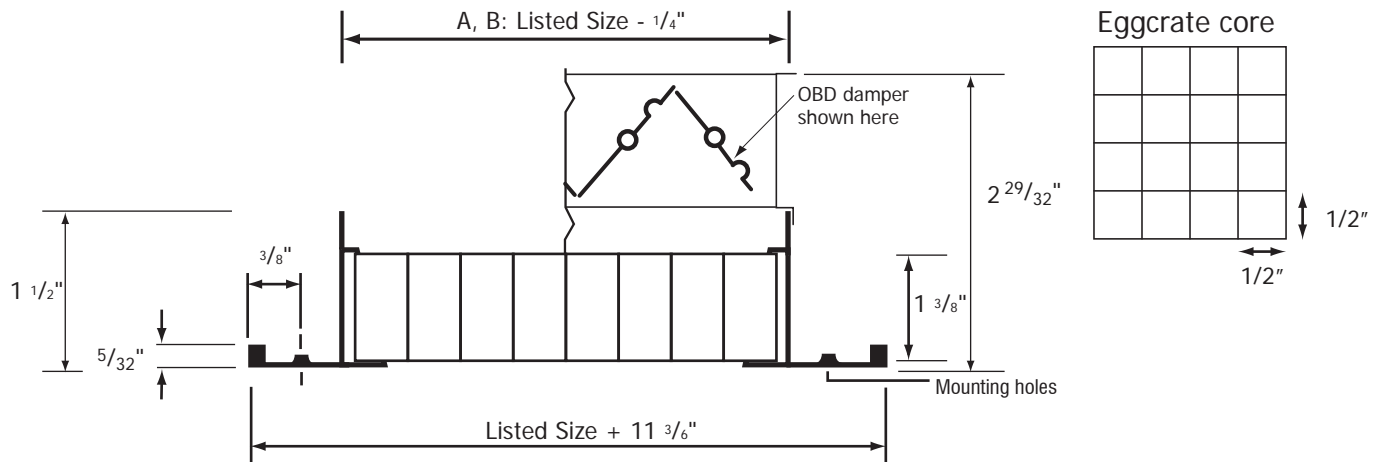
Eggcrate Return Grille for Surface Mount



Material: All aluminium construction.
Mounting: Drywall or any surface mounting.
 Countersunk mounting holes on frame.
Grid core: Aluminum $1/2" \times 1/2" \times 1"$.

- ERE1** (without OBD damper)
 ERE17 (with OBD damper)

ERE1 / ERE17
 (ERE 2424 shown here)



Options		
<input type="checkbox"/> -SF Supplied w/ sub frame	<input type="checkbox"/> -DS Debris (Bird) Screen	<input type="checkbox"/> -IS Insect Screen
<input type="checkbox"/> -GK Flange Gasket	<input type="checkbox"/> -GN Neck Gasket	

Size limits	Width A		Height B	
	in	mm	in	mm
Minimum	4	102	4	102
Maximum	48	1219	48	1219

Fastening Method	
<input type="checkbox"/> -1 No Fastening	<input type="checkbox"/> -3 Screw holes (Standard)



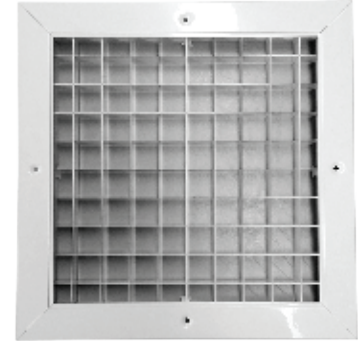
Panel Option for T-bar lay-in Ceiling		
	Steel (WxH)	Aluminum (WxH)
	<input type="checkbox"/> -X1212	<input type="checkbox"/> -Y1212
	<input type="checkbox"/> -X1224	<input type="checkbox"/> -Y1224
	<input type="checkbox"/> -X2412	<input type="checkbox"/> -Y2412
	<input type="checkbox"/> -X2424	<input type="checkbox"/> -Y2424
	<input type="checkbox"/> -X2448	<input type="checkbox"/> -Y2448
	<input type="checkbox"/> -X4824	<input type="checkbox"/> -Y4824
	<input type="checkbox"/> -X2020	<input type="checkbox"/> -Y2020
	No fastening options available	

Finish	
<input type="checkbox"/> /W White (default)	<input type="checkbox"/> Custom (please specify)

Schedule type: _____
 Job: _____
 Architect: _____
 Engineer: _____
 Contractor: _____

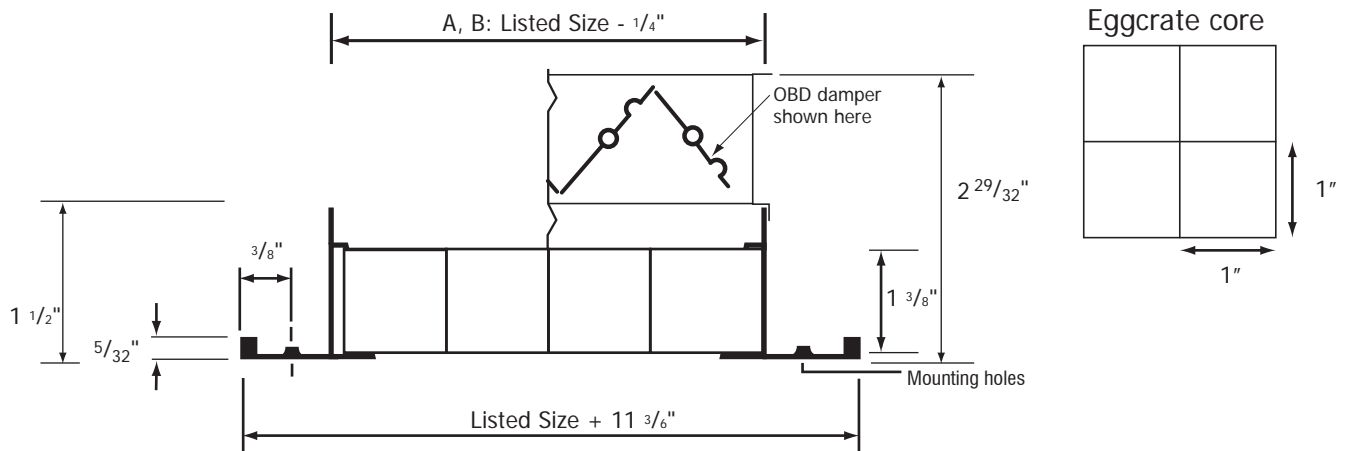
Eggcrate Return Grille for Surface Mount, 1" square cell size

Material: All aluminium construction.
Mounting: Drywall or any surface mounting.
 Countersunk mounting holes on frame.
Grid core: Aluminum 1" x 1" x 1".



ERE3 / ERE37

- ERE3** (without OBD damper)
- ERE37** (with OBD damper)



Options		
<input type="checkbox"/> -SF Supplied w/ sub frame	<input type="checkbox"/> -DS Debris (Bird) Screen	<input type="checkbox"/> -IS Insect Screen
<input type="checkbox"/> -GK Flange Gasket	<input type="checkbox"/> -GN Neck Gasket	

Size limits	Width A		Height B	
	in	mm	in	mm
Minimum	4	102	4	102
Maximum	48	1219	48	1219

Fastening Method	
<input type="checkbox"/> -1 No Fastening	<input type="checkbox"/> -3 Screw holes (Standard)



Panel Option for T-bar lay-in Ceiling	
Steel (WxH)	Aluminum (WxH)
<input type="checkbox"/> -X1212	<input type="checkbox"/> -Y1212
<input type="checkbox"/> -X1224	<input type="checkbox"/> -Y1224
<input type="checkbox"/> -X2412	<input type="checkbox"/> -Y2412
<input type="checkbox"/> -X2424	<input type="checkbox"/> -Y2424
<input type="checkbox"/> -X2448	<input type="checkbox"/> -Y2448
<input type="checkbox"/> -X4824	<input type="checkbox"/> -Y4824
<input type="checkbox"/> -X2020	<input type="checkbox"/> -Y2020

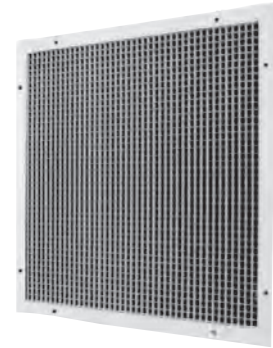
No fastening options available

Finish	
<input type="checkbox"/> /W White (default)	<input type="checkbox"/> Custom (please specify)

Schedule type: _____
 Job: _____
 Architect: _____
 Engineer: _____
 Contractor: _____

Eggcrate Return Grille for Surface Mount 45° Angled Eggcrate

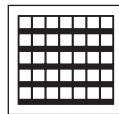
Material: All aluminium construction.
Mounting: Drywall or any surface mounting.
 Countersunk mounting holes on frame.
Grid core: Aluminum 1/2" x 1/2" x 1/2". 45° Angled Eggcrate Core



ERE5 / ERE57
(ERE 2424 shown here)

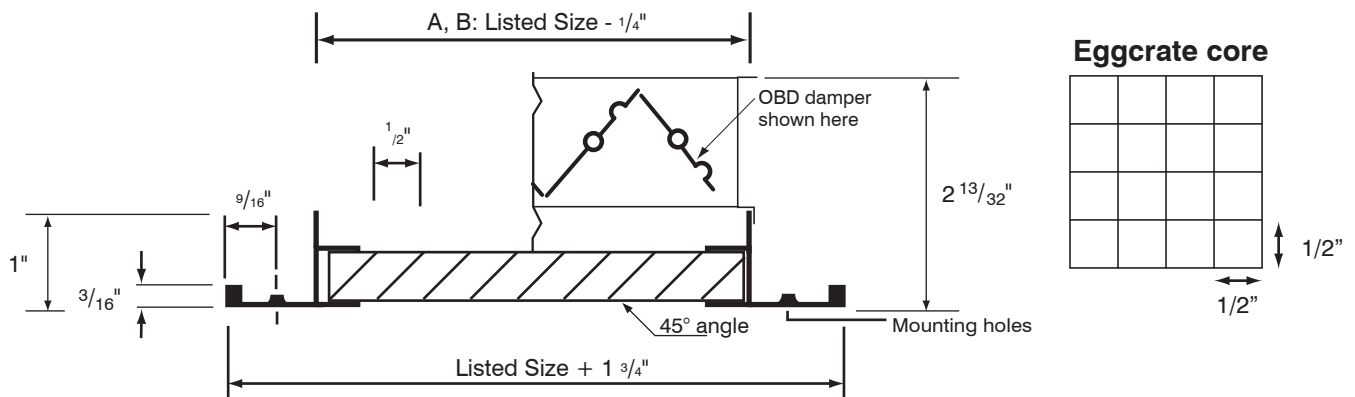
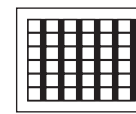
Horizontal Air Flow (Standard)

- ERE50**
 ERE57 with OBD



Vertical Face Bars

- ERE50-V**
 ERE57-V with OBD



Options		
<input type="checkbox"/> -SF Supplied w/ sub frame	<input type="checkbox"/> -DS Debris (Bird) Screen	<input type="checkbox"/> -IS Insect Screen
<input type="checkbox"/> -GK Flange Gasket	<input type="checkbox"/> -GN Neck Gasket	

Size limits	Width A		Height B	
	in	mm	in	mm
Minimum	4	102	4	102
Maximum	48	1219	48	1219

Fastening Method	
<input type="checkbox"/> -1 No Fastening	<input type="checkbox"/> -3 Screw holes (Standard)



Panel Option for T-bar lay-in Ceiling		
	Steel (WxH)	Aluminum (WxH)
	<input type="checkbox"/> -X1212	<input type="checkbox"/> -Y1212
	<input type="checkbox"/> -X1224	<input type="checkbox"/> -Y1224
	<input type="checkbox"/> -X2412	<input type="checkbox"/> -Y2412
	<input type="checkbox"/> -X2424	<input type="checkbox"/> -Y2424
	<input type="checkbox"/> -X2448	<input type="checkbox"/> -Y2448
	<input type="checkbox"/> -X4824	<input type="checkbox"/> -Y4824
	<input type="checkbox"/> -X2020	<input type="checkbox"/> -Y2020

No fastening options available

Finish	
<input type="checkbox"/> /W White (default)	<input type="checkbox"/> /C Custom (please specify)

Schedule type: _____
 Job: _____
 Architect: _____
 Engineer: _____
 Contractor: _____

SUBMITTAL SHEET

Aluminum Egg Crate Return with Molded Fiberglass Back Panel

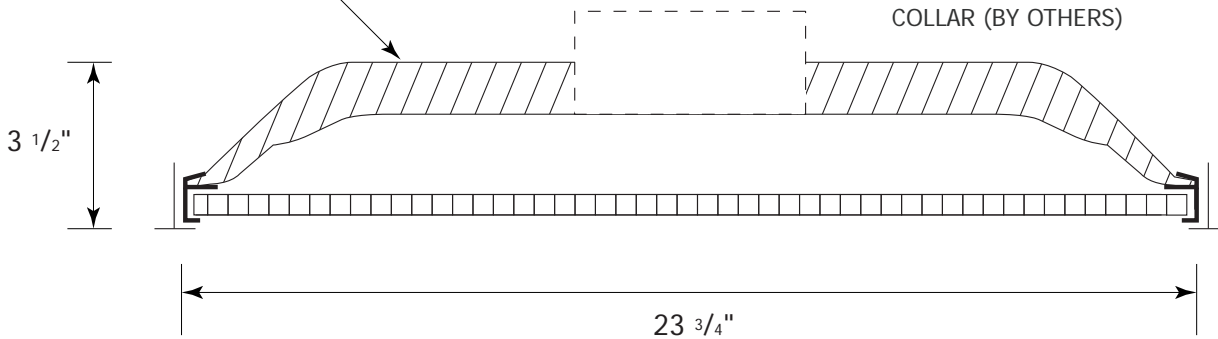


- Material:** Molded fiberglass back with aluminum foil vapor barrier scored for 6" to 14" D. in an extruded aluminum fixed frame.
- Grid core:** Aluminum 1/2" X 1/2" X 1/2".
- Finish:** Powder paint coating - white.
- Mounting:** T-bar Lay-in ceiling.

ERI

Fiberglass back complies with A.S.T.M. E84 flame and smoke test. Scored for collar sizes up to 14" D.

R4 R6



Schedule type: _____

Job: _____

Architect: _____

Engineer: _____

Contractor: _____

Aluminum Egg Crate Return with Molded Fiberglass Back Panel 45° Angled Eggcrate

- Material:** Molded fiberglass back with aluminum foil vapor barrier scored for 6" to 14" D. in an extruded aluminum fixed frame.
- Grid core:** Aluminum 1/2" X 1/2" X 1/2" 45° Angled Eggcrate Core.
- Finish:** Powder paint coating - white.
- Mounting:** T-bar Lay-in ceiling.

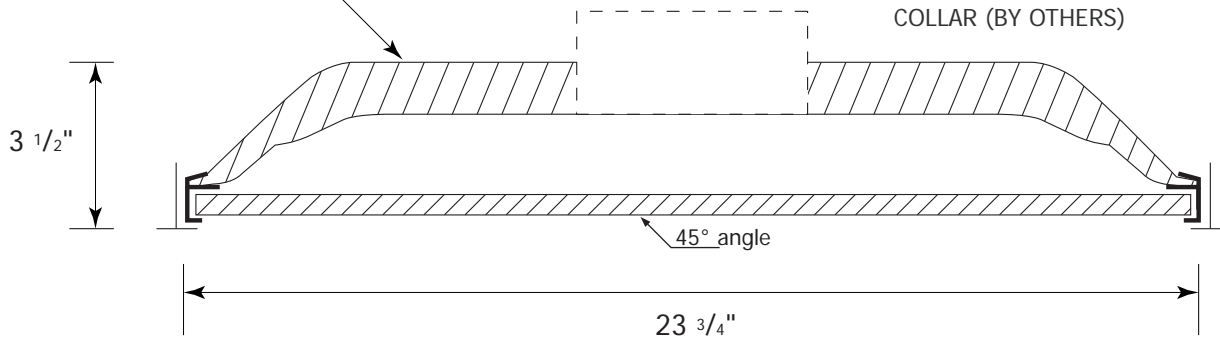


ERI5

Fiberglass back complies with A.S.T.M. E84 flame and smoke test. Scored for collar sizes up to 14" D.

R4

R6



Schedule type:	_____
Job:	_____
Architect:	_____
Engineer:	_____
Contractor:	_____

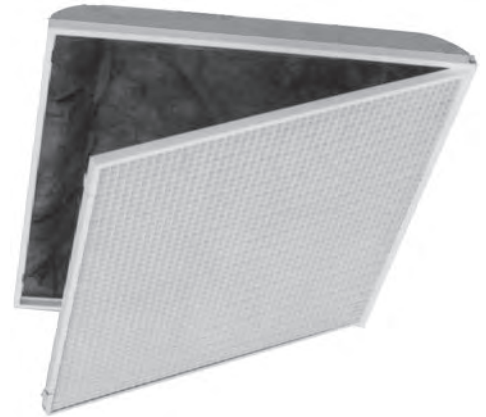
SUBMITTAL SHEET

Aluminum Egg Crate Filter Return with Molded Fiberglass Back Panel Hinged face

Material: Molded fiberglass back with aluminum foil vapor barrier scored for 6" to 14" D. in an extruded aluminum fixed frame. Aluminum grid 1/2"x1/2"x1/2" in hinged extruded aluminum U frame, swing in and out of fixed frame for access to 20"x20" filter, by others.

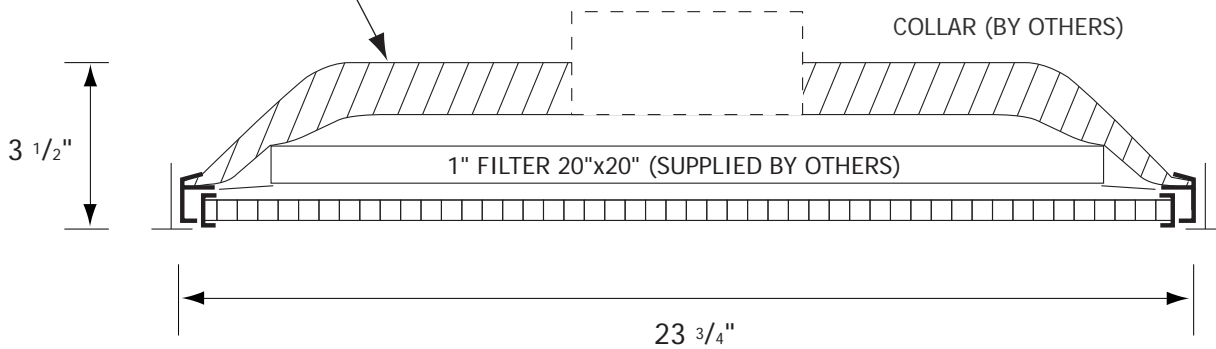
Finish: Powder paint coating - white.

Mounting: T-bar Lay-in ceiling.



ERIF

Fiberglass back complies with A.S.T.M. E84 flame and smoke test. Scored for collar sizes up to 14" D.
 R4 R6



Finish	
<input type="checkbox"/> /W White (default)	<input type="checkbox"/> Custom (please specify)



Schedule type: _____
Job: _____
Architect: _____
Engineer: _____
Contractor: _____

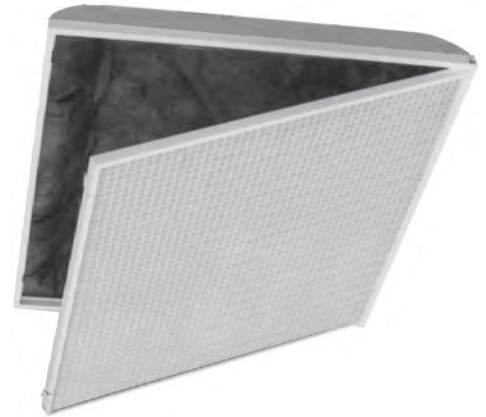
Aluminum Egg Crate Filter Return with Molded Fiberglass Back Panel Hinged face - 45° Angled Eggcrate

Material: Molded fiberglass back with aluminum foil vapor barrier scored for 6" to 14" D. in an extruded aluminum fixed frame. Aluminum grid 1/2"x1/2"x1/2" in hinged extruded aluminum U frame, swing in and out of fixed frame for access to 20"x20" filter, by others.

Finish: Powder paint coating - white.

Mounting: T-bar Lay-in ceiling.

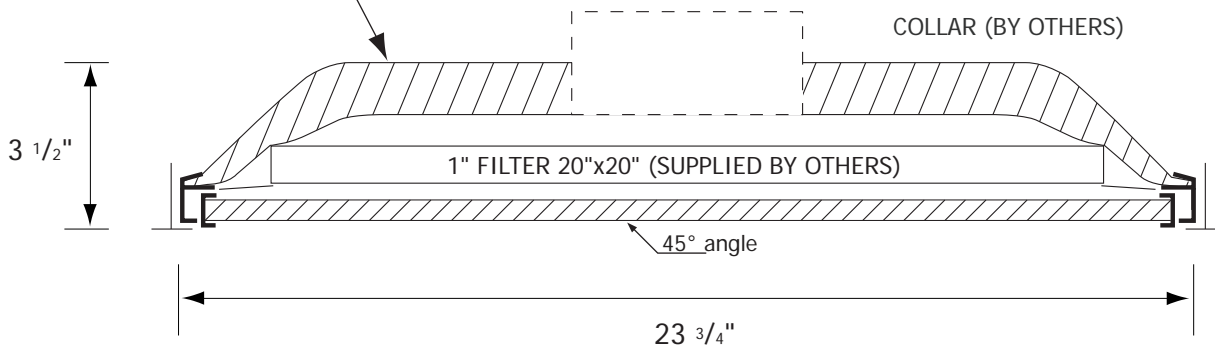
Grid core: 45° Angled Eggcrate Core



ERIF5

Fiberglass back complies with A.S.T.M. E84 flame and smoke test. Scored for collar sizes up to 14" D.

R4 R6



Finish	
<input type="checkbox"/> /W White (default)	<input type="checkbox"/> Custom (please specify)



Schedule type: _____

Job: _____

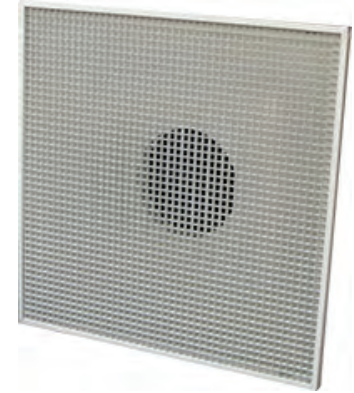
Architect: _____

Engineer: _____

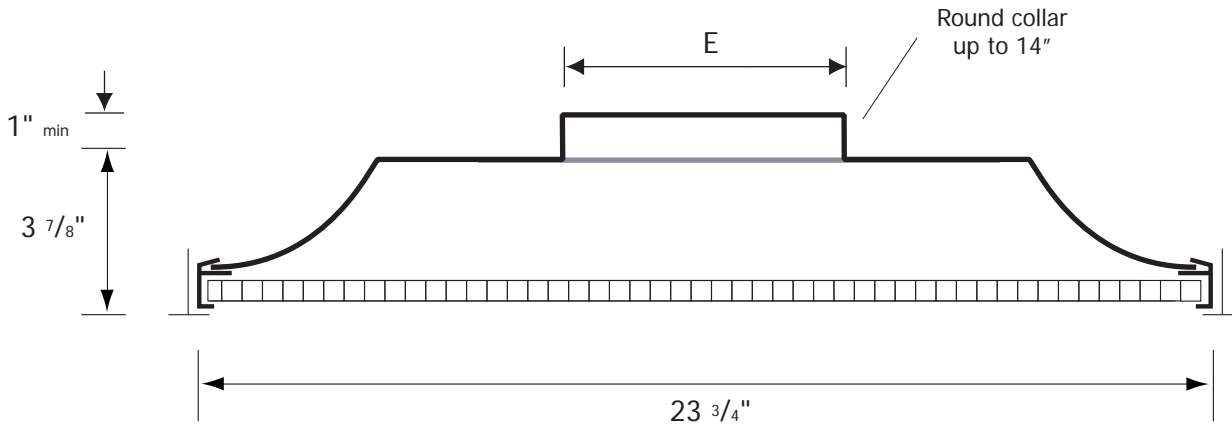
Contractor: _____

Aluminum Egg Crate Return with Steel Back Panel

- Material:** Stamped heavy gauge steel in an extruded aluminum fixed frame.
- Grid core:** Aluminum 1/2" X 1/2" X 1/2".
- Finish:** Powder paint coating - white.
- Mounting:** T-bar Lay-in ceiling.



ERM



✓	Model #	Duct Size	E	Face Dim
	ERM 1206	6	5 7/8"	11 3/4" X 11 3/4"
	ERM 1208	8	7 7/8"	11 3/4" X 11 3/4"
	ERM 2406	6	5 7/8"	23 3/4" X 23 3/4"
	ERM 2408	8	7 7/8"	23 3/4" X 23 3/4"
	ERM 2410	10	9 7/8"	23 3/4" X 23 3/4"
	ERM 2412	12	11 7/8"	23 3/4" X 23 3/4"
	ERM 2414	14	13 7/8"	23 3/4" X 23 3/4"
	ERM 2416	16	15 7/8"	23 3/4" X 23 3/4"

Finish	
<input type="checkbox"/> /W White (Default)	<input type="checkbox"/> /C Custom (Please Specify)



Schedule type: _____

Job: _____

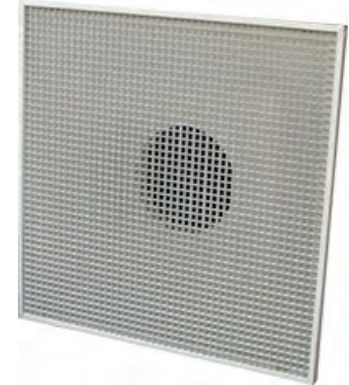
Architect: _____

Engineer: _____

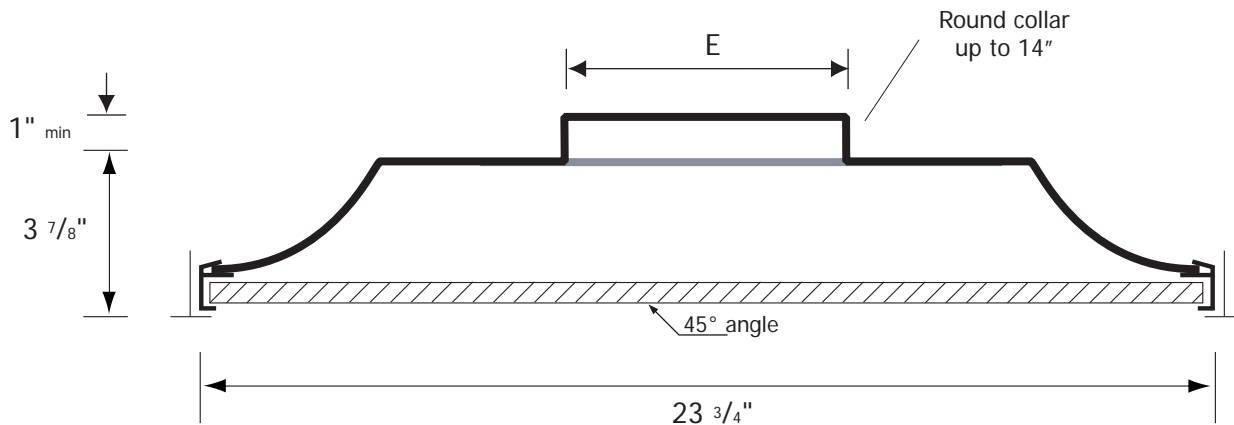
Contractor: _____

Aluminum Egg Crate Return with Steel Back Panel 45° Angled Eggcrate

- Material:** Stamped heavy gauge steel in an extruded aluminum fixed frame.
- Grid core:** Aluminum 1/2" X 1/2" X 1/2" - 45° Angled Eggcrate Core.
- Finish:** Powder paint coating - white.
- Mounting:** T-bar Lay-in ceiling.



ERM5



✓	Model #	Duct Size	E	Face Dim
	ERM5 1206	6	5 7/8"	11 3/4" x 11 3/4"
	ERM5 1208	8	7 7/8"	11 3/4" x 11 3/4"
	ERM5 2406	6	5 7/8"	23 3/4" x 23 3/4"
	ERM5 2408	8	7 7/8"	23 3/4" x 23 3/4"
	ERM5 2410	10	9 7/8"	23 3/4" x 23 3/4"
	ERM5 2412	12	11 7/8"	23 3/4" x 23 3/4"
	ERM5 2414	14	13 7/8"	23 3/4" x 23 3/4"
	ERM5 2416	16	15 7/8"	23 3/4" x 23 3/4"

Finish	
<input type="checkbox"/> /W White (default)	<input type="checkbox"/> Custom (please specify)



Schedule type: _____
Job: _____
Architect: _____
Engineer: _____
Contractor: _____

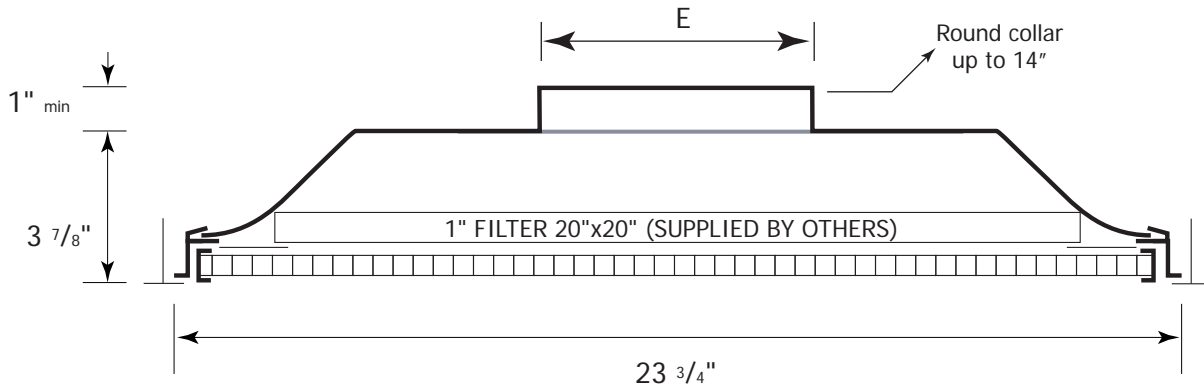
Aluminum Egg Crate Filter Return with Steel Back Panel Hinged face

Material: Stamped heavy gauge steel back panels with reinforcing corners. Aluminum grid 1/2"x 1/2"x 1/2" in hinged extruded aluminum U frame swings in and out of fixed frame for access to 20" x 20" filter, by others.

Finish: Powder paint coating - white.
Mounting: T-bar Lay-in ceiling.



ERMF



Finish	
<input type="checkbox"/> /W White (Default)	<input type="checkbox"/> /C Custom (Please Specify)



✓	Model #	Duct Size	E	Face Dim
	ERMF 2406	6	5 7/8"	23 3/4" x 23 3/4"
	ERMF 2408	8	7 7/8"	23 3/4" x 23 3/4"
	ERMF 2410	10	9 7/8"	23 3/4" x 23 3/4"
	ERMF 2412	12	11 7/8"	23 3/4" x 23 3/4"
	ERMF 2414	14	13 7/8"	23 3/4" x 23 3/4"

Schedule type: _____

Job: _____

Architect: _____

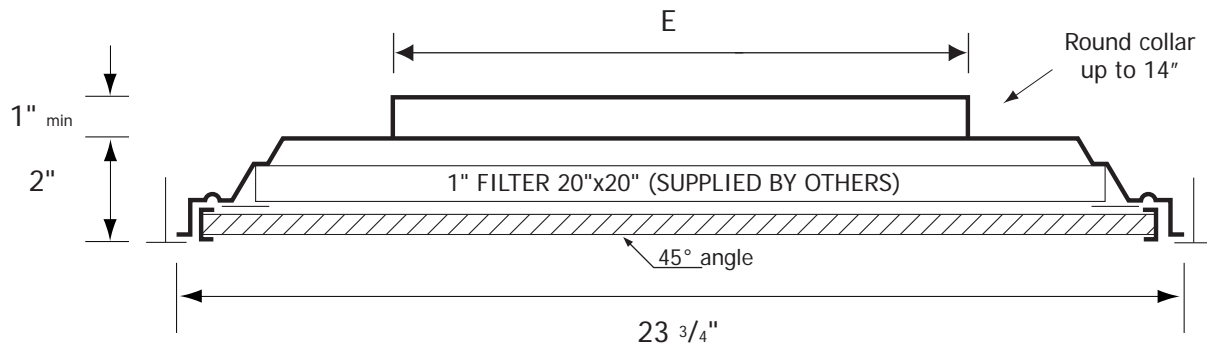
Engineer: _____

Contractor: _____

Aluminum Egg Crate Filter Return with Steel Back Panel - Hinged face 45° Angled Eggcrate



- Material:** Stamped heavy gauge steel back panels with reinforcing corners. Aluminum grid 1/2"x 1/2"x 1/2" in hinged extruded aluminum U frame swings in and out of fixed frame for access to 20" x 20" filter, by others.
- Grid core:** 45° Angled Eggcrate Core
- Finish:** Powder paint coating - white.
- Mounting:** T-bar Lay-in ceiling.

ERMF5


✓	Model #	Duct Size	E	Face Dim
	ERMF5 2406	6	5 7/8"	23 3/4" x 23 3/4"
	ERMF5 2408	8	7 7/8"	23 3/4" x 23 3/4"
	ERMF5 2410	10	9 7/8"	23 3/4" x 23 3/4"
	ERMF5 2412	12	11 7/8"	23 3/4" x 23 3/4"
	ERMF5 2414	14	13 7/8"	23 3/4" x 23 3/4"

Finish	
<input type="checkbox"/> /W White (default)	<input type="checkbox"/> Custom (please specify)

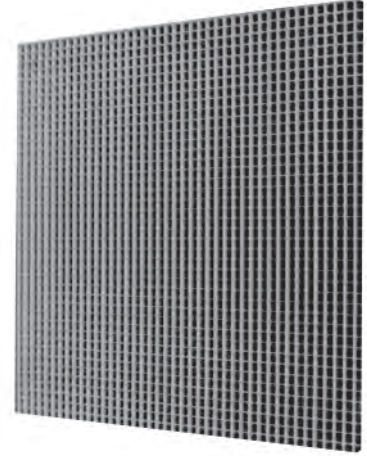


Schedule type: _____
Job: _____
Architect: _____
Engineer: _____
Contractor: _____

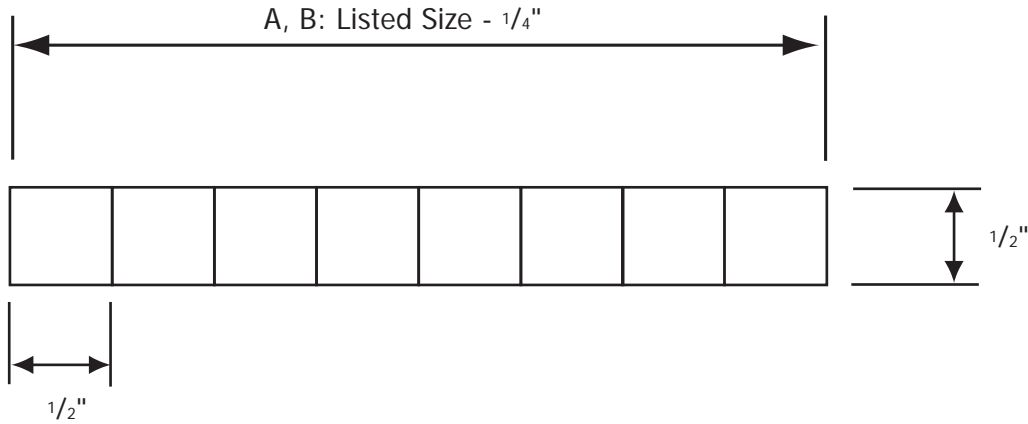
Eggcrate Return Grille - Core Only

- Material:** All aluminum
- Mounting:** Lay-in T-bar ceiling
- Grid core:** Aluminum 1/2" X 1/2" X 1/2"

Custom Face Dimensions Available
up to 48" x 24"



ERN
Aluminum Grid Core



✓	Model Listed Size	Face Dim. A x B
	ERN 1212	11 3/4" x 11 3/4"
	ERN 2412	23 3/4" x 11 3/4"
	ERN 2424	23 3/4" x 23 3/4"
	ERN 4824	47 3/4" x 23 3/4"
	ERN _____ A (Length) B (Width) Max Size 48" x 24"	A - 1/4" " x B - 1/4"

Finish		
<input type="checkbox"/> /W White (default)	<input type="checkbox"/> /M Mill (Raw Aluminum)	<input type="checkbox"/> Custom (please specify)

Schedule type: _____

Job: _____

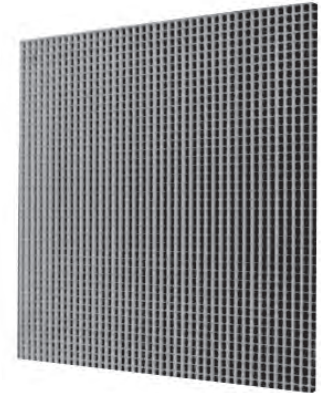
Architect: _____

Engineer: _____

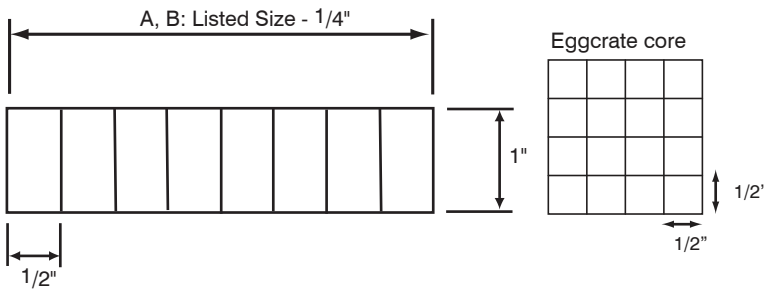
Contractor: _____

Eggcrate Return Grille - Core Only

Material: All aluminum.
Mounting: Lay-in T-bar ceiling.
Grid cores: ERN1: 1/2" X 1/2" X 1"
 ERN3: 1" X 1" X 1"
 ERN5: 1/2" X 1/2" X 1/2"



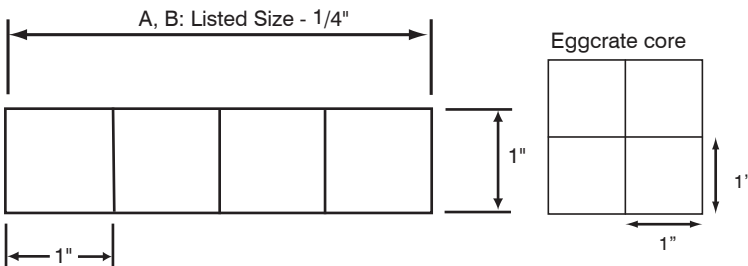
ERN1



ERN1
(Aluminum Grid Core)

ERN			Listed Size	Face Dim. A x B
<input checked="" type="checkbox"/>	<input type="checkbox"/>	<input type="checkbox"/>		
<input type="checkbox"/>	<input type="checkbox"/>	<input type="checkbox"/>	1212	11 3/4" x 11 3/4"
<input type="checkbox"/>	<input type="checkbox"/>	<input type="checkbox"/>	2406	23 3/4" x 5 3/4"
<input type="checkbox"/>	<input type="checkbox"/>	<input type="checkbox"/>	2408	23 3/4" x 7 3/4"
<input type="checkbox"/>	<input type="checkbox"/>	<input type="checkbox"/>	2412	23 3/4" x 11 3/4"
<input type="checkbox"/>	<input type="checkbox"/>	<input type="checkbox"/>	2424	23 3/4" x 23 3/4"
<input type="checkbox"/>	<input type="checkbox"/>	<input type="checkbox"/>	4806	47 3/4" x 5 3/4"
<input type="checkbox"/>	<input type="checkbox"/>	<input type="checkbox"/>	4808	47 3/4" x 7 3/4"
<input type="checkbox"/>	<input type="checkbox"/>	<input type="checkbox"/>	4812	47 3/4" x 11 3/4"
<input type="checkbox"/>	<input type="checkbox"/>	<input type="checkbox"/>	4824	47 3/4" x 23 3/4"
			Custom Dim.	A - 1/4" x B - 1/4"
			A (Length) B (Width) (please specify) Max Size 48" x 24"	

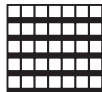
ERN3



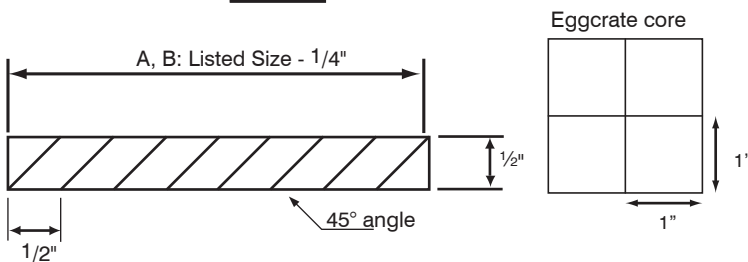
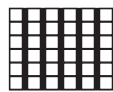
ERN5

Horizontal Air Flow (Standard) **Vertical Air Flow**

FER5



FER5-V



Finish		
<input type="checkbox"/> /W White (Default)	<input type="checkbox"/> /M Mill	<input type="checkbox"/> /C Custom (Please Specify)



Schedule type: _____

Job: _____

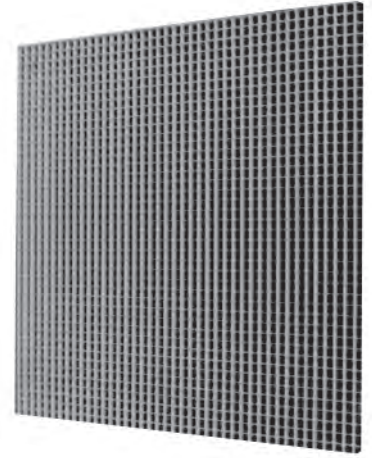
Architect: _____

Engineer: _____

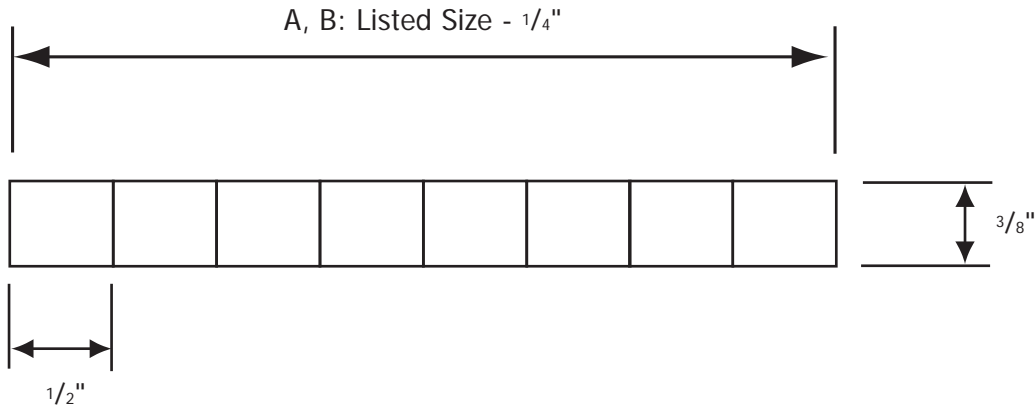
Contractor: _____

Eggcrate Return Grille - Core Only

Material: Polystyrene-based material.
Finish: White color.
Mounting: Lay-in T-bar ceiling.
Grid core: Plastic 1/2" X 1/2" X 3/8".



ERN-P
Plastic Grid Core



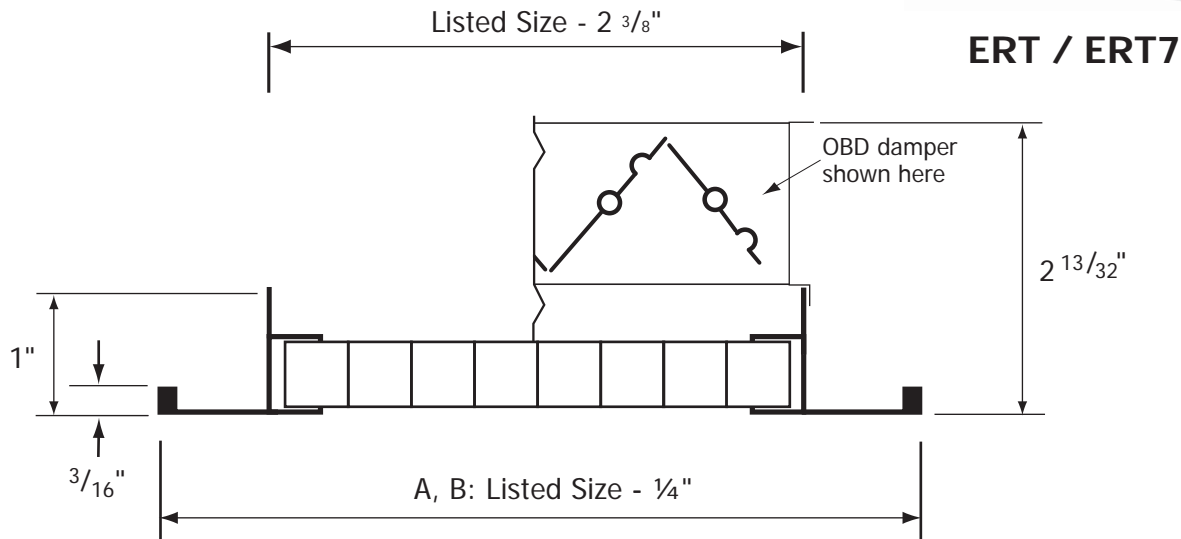
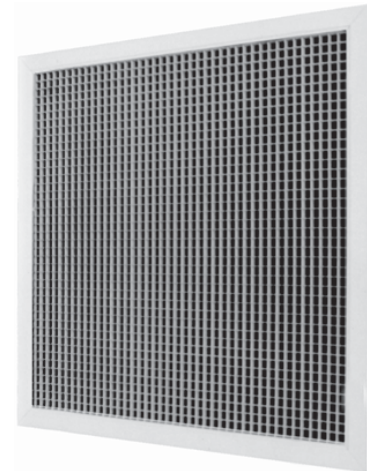
Any even dimension up to 48"x24" available

✓	Model Listed Size	Face Dim. A x B
	ERN-P 1212	11 3/4" x 11 3/4"
	ERN-P 2412	23 3/4" x 11 3/4"
	ERN-P 2424	23 3/4" x 23 3/4"
	ERN-P 4824	47 3/4" x 23 3/4"
	ERN-P _____ A (Length) B (Width) Max Size 48" x 24"	A - 1/4" " X B - 1/4"

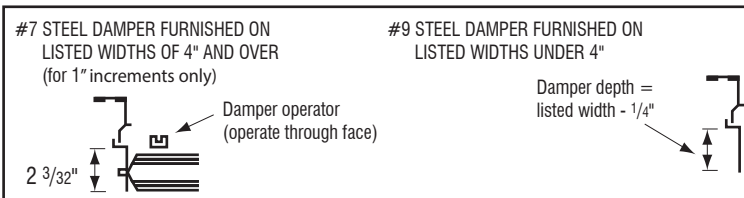
Schedule type: _____
 Job: _____
 Architect: _____
 Engineer: _____
 Contractor: _____

Eggcrate Return Grille, T-Bar Mount

Material: All aluminium construction.
Mounting: Lay-in T-bar ceiling.
 No mounting holes. 1 1/4" Frame
Grid core: Aluminium 1/2" X 1/2" X 1/2".



ERT / ERT7



✓	Model #	Face Dim. A x B	Neck
	ERT 1212	11 3/4" x 11 3/4"	9 5/8" x 9 5/8"
	ERT 2412	23 3/4" x 11 3/4"	21 5/8" x 9 5/8"
	ERT 2424	23 3/4" x 23 3/4"	21 5/8" x 21 5/8"
	ERT 4812	47 3/4" x 11 3/4"	46 5/8" x 9 5/8"
	ERT 4824	47 3/4" x 23 3/4"	46 5/8" x 21 5/8"
	ERT7 1212	11 3/4" x 11 3/4"	9 5/8" x 9 5/8"
	ERT7 2412	23 3/4" x 11 3/4"	21 5/8" x 9 5/8"
	ERT7 2424	23 3/4" x 23 3/4"	21 5/8" x 21 5/8"
	ERT7 4812	47 3/4" x 11 3/4"	46 5/8" x 9 5/8"
	ERT7 4824	47 3/4" x 23 3/4"	46 5/8" x 21 5/8"

Custom dimensions available upon request.

Finish	
<input type="checkbox"/> /W White (default)	<input type="checkbox"/> Custom (please specify)



Schedule type: _____

Job: _____

Architect: _____

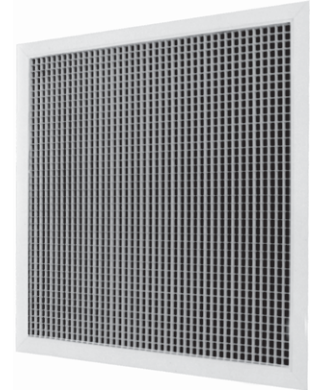
Engineer: _____

Contractor: _____

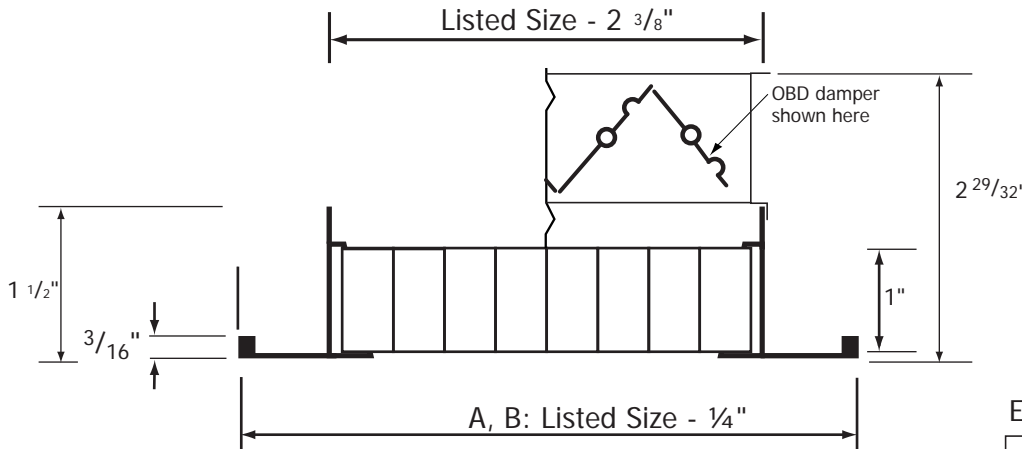
SUBMITTAL SHEET

Eggcrate Return Grille 1" thick core, T-Bar Mount

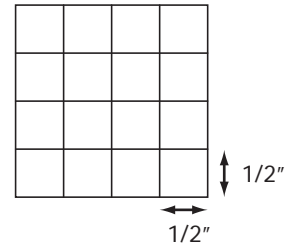
- Material:** All aluminium construction.
- Mounting:** Lay-in T-bar ceiling.
No mounting holes. 1 1/4" Frame
- Grid core:** Aluminium 1/2" X 1/2" X 1".



ERT1 / ERT17

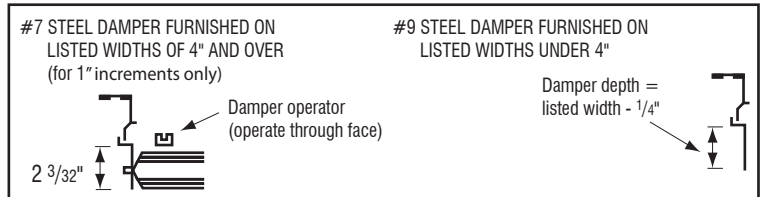


Eggcrate core



✓	Model #	Face Dim. A x B	Neck
	ERT1 1212	11 3/4" x 11 3/4"	9 5/8" x 9 5/8"
	ERT1 2412	23 3/4" x 11 3/4"	21 5/8" x 9 5/8"
	ERT1 2424	23 3/4" x 23 3/4"	21 5/8" x 21 5/8"
	ERT1 4812	47 3/4" x 11 3/4"	46 5/8" x 9 5/8"
	ERT1 4824	47 3/4" x 23 3/4"	46 5/8" x 21 5/8"
	ERT17 1212	11 3/4" x 11 3/4"	9 5/8" x 9 5/8"
	ERT17 2412	23 3/4" x 11 3/4"	21 5/8" x 9 5/8"
	ERT17 2424	23 3/4" x 23 3/4"	21 5/8" x 21 5/8"
	ERT17 4812	47 3/4" x 11 3/4"	46 5/8" x 9 5/8"
	ERT17 4824	47 3/4" x 23 3/4"	46 5/8" x 21 5/8"

Custom dimensions available upon request.



Panel Option for T-bar lay-in Ceiling		Steel (WxH)	Aluminum (WxH)
	<input type="checkbox"/>	-X1212	<input type="checkbox"/> -Y1212
	<input type="checkbox"/>	-X2412	<input type="checkbox"/> -Y2412
	<input type="checkbox"/>	-X2424	<input type="checkbox"/> -Y2424
	<input type="checkbox"/>	-X4812	<input type="checkbox"/> -Y4812
	<input type="checkbox"/>	-X4824	<input type="checkbox"/> -Y4824

No fastening options available

Finish	
<input type="checkbox"/> /W White (default)	<input type="checkbox"/> Custom (please specify)



Schedule type: _____

Job: _____

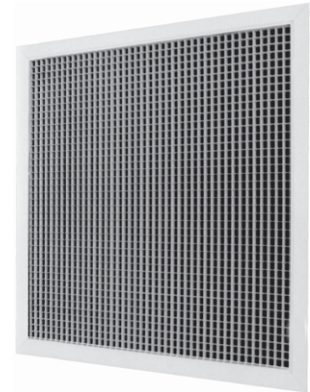
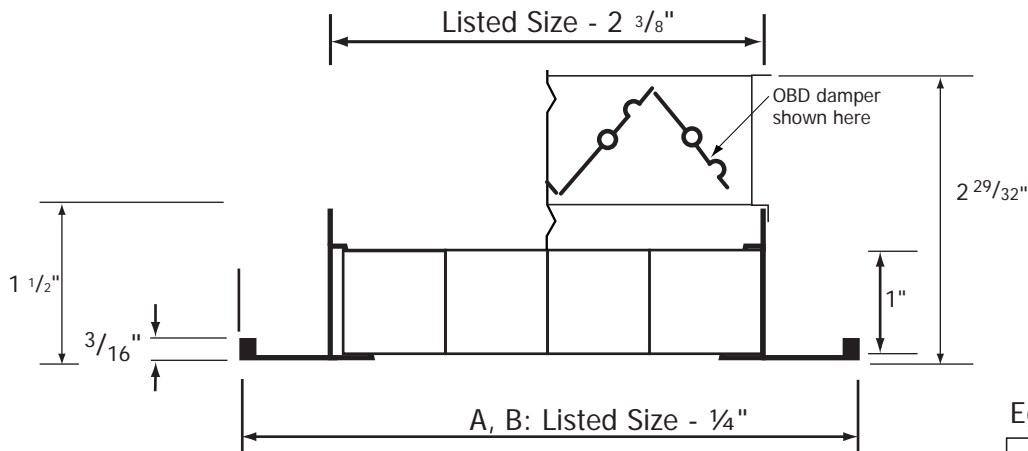
Architect: _____

Engineer: _____

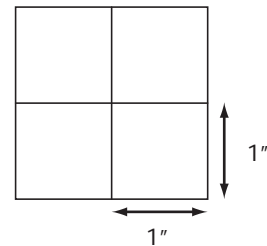
Contractor: _____

Eggcrate Return Grille, T-Bar Mount, 1" square cell size

Material: All aluminium construction.
Mounting: Lay-in T-bar ceiling.
 No mounting holes. 1 1/4" Frame
Grid core: Aluminium 1" x 1" x 1".

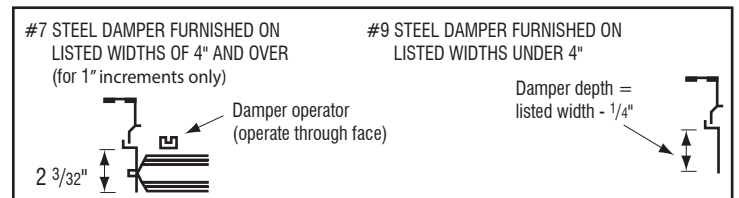

ERT3 / ERT37


Eggcrate core



✓	Model #	Face Dim. A x B	Neck
	ERT3 1212	11 3/4" x 11 3/4"	9 5/8" x 9 5/8"
	ERT3 2412	23 3/4" x 11 3/4"	21 5/8" x 9 5/8"
	ERT3 2424	23 3/4" x 23 3/4"	21 5/8" x 21 5/8"
	ERT3 4812	47 3/4" x 11 3/4"	46 5/8" x 9 5/8"
	ERT3 4824	47 3/4" x 23 3/4"	46 5/8" x 21 5/8"
	ERT37 1212	11 3/4" x 11 3/4"	9 5/8" x 9 5/8"
	ERT37 2412	23 3/4" x 11 3/4"	21 5/8" x 9 5/8"
	ERT37 2424	23 3/4" x 23 3/4"	21 5/8" x 21 5/8"
	ERT37 4812	47 3/4" x 11 3/4"	46 5/8" x 9 5/8"
	ERT37 4824	47 3/4" x 23 3/4"	46 5/8" x 21 5/8"

Custom dimensions available upon request.



Panel Option for T-bar lay-in Ceiling		Steel (WxH)	Aluminum (WxH)
<p>No fastening options available</p>		<input type="checkbox"/> -X1212	<input type="checkbox"/> -Y1212
		<input type="checkbox"/> -X2412	<input type="checkbox"/> -Y2412
		<input type="checkbox"/> -X2424	<input type="checkbox"/> -Y2424
		<input type="checkbox"/> -X4812	<input type="checkbox"/> -Y4812
		<input type="checkbox"/> -X4824	<input type="checkbox"/> -Y4824

Finish	
<input type="checkbox"/> /W White (default)	<input type="checkbox"/> Custom (please specify)



Schedule type: _____

Job: _____

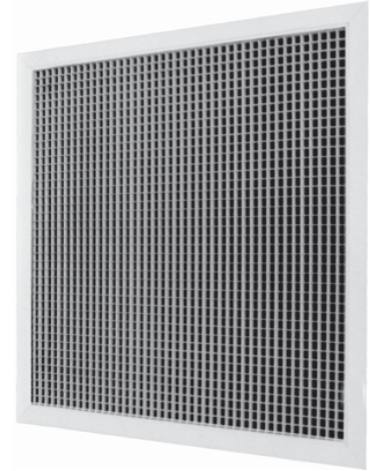
Architect: _____

Engineer: _____

Contractor: _____

Eggcrate Return Grille, T-Bar Mount 45° Angled Eggcrate

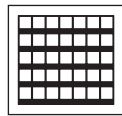
- Material:** All aluminium construction.
Mounting: Lay-in T-bar ceiling.
 No mounting holes. 1 1/4" Frame
Grid core: Aluminium 1/2" x 1/2" x 1/2"
 45° Angled Eggcrate Core



ERT5 / ERT57

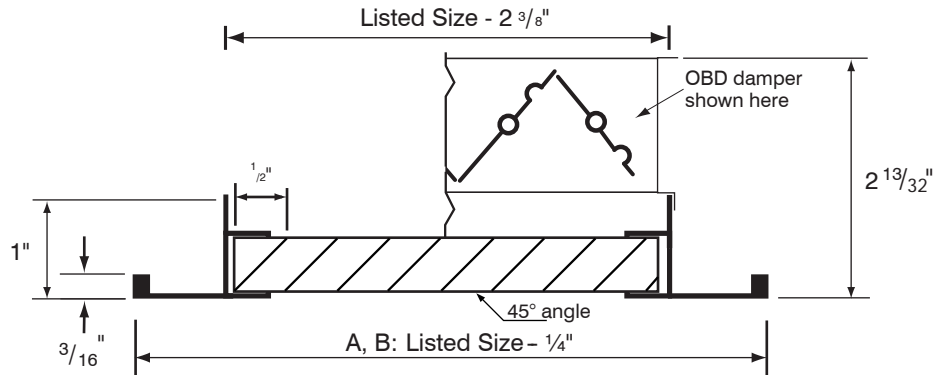
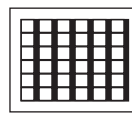
Horizontal Air Flow (Standard)

- ERT5**
 ERT57 with OBD



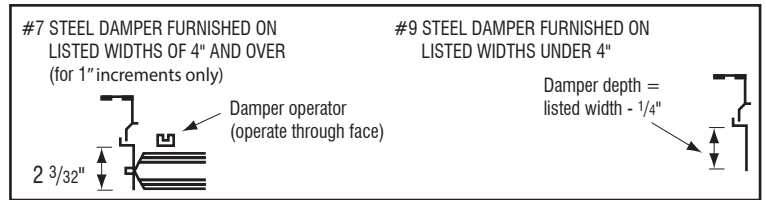
Vertical Face Bars

- ERT5-V**
 ERT57-V with OBD



✓	Model #	Face Dim. A x B	Neck
	ERT5 1212	11 3/4" x 11 3/4"	9 5/8" x 9 5/8"
	ERT5 2412	23 3/4" x 11 3/4"	21 5/8" x 9 5/8"
	ERT5 2424	23 3/4" x 23 3/4"	21 5/8" x 21 5/8"
	ERT5 4812	47 3/4" x 11 3/4"	46 5/8" x 9 5/8"
	ERT5 4824	47 3/4" x 23 3/4"	46 5/8" x 21 5/8"
	ERT57 1212	11 3/4" x 11 3/4"	9 5/8" x 9 5/8"
	ERT57 2412	23 3/4" x 11 3/4"	21 5/8" x 9 5/8"
	ERT57 2424	23 3/4" x 23 3/4"	21 5/8" x 21 5/8"
	ERT57 4812	47 3/4" x 11 3/4"	46 5/8" x 9 5/8"
	ERT57 4824	47 3/4" x 23 3/4"	46 5/8" x 21 5/8"

Custom dimensions available upon request.



Panel Option for T-bar lay-in Ceiling

W	H	Steel (WxH)		Aluminum (WxH)	
		<input type="checkbox"/> -X1212	<input type="checkbox"/> -Y1212	<input type="checkbox"/> -X2412	<input type="checkbox"/> -Y2412
		<input type="checkbox"/> -X4812	<input type="checkbox"/> -Y4812	<input type="checkbox"/> -X4824	<input type="checkbox"/> -Y4824

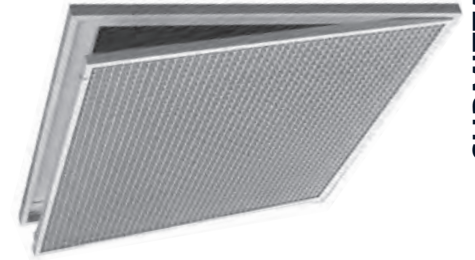
No fastening options available

Finish	
<input type="checkbox"/> /W White (default)	<input type="checkbox"/> /C Custom (please specify)

Schedule type: _____
 Job: _____
 Architect: _____
 Engineer: _____
 Contractor: _____

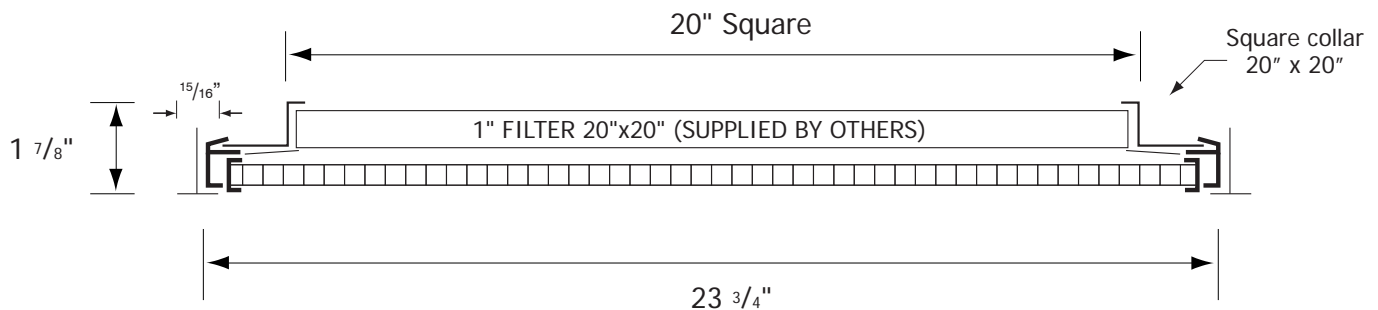
Aluminum Egg Crate Filter Return with 20" x 20" Filter Frame Hinged face - Steel Back

Material: Steel filter frame will accept 20"x20" standard 1" filter. Aluminum egg crate grid 1/2"x1/2"x1/2" in hinged extruded aluminum U frame, swings in and out of fixed frame for access to 20" x 20" filter, by others.



Finish: Powder paint coating - white.
Mounting: T-bar Lay-in ceiling.

ERTF



Mounting	
<input type="checkbox"/> -NT	Narrow T-bar

Finish	
<input type="checkbox"/> /W	White (Default)
<input type="checkbox"/> /C	Custom (Please Specify)



Schedule type: _____

Job: _____

Architect: _____

Engineer: _____

Contractor: _____

SUBMITTAL SHEET

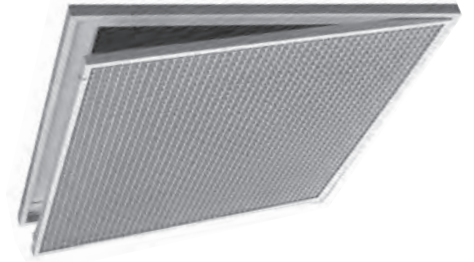
Aluminum Egg Crate Filter Return with 20" x 20" Filter Frame Hinged face - Steel Back 45° Angled Eggcrate

Material: Steel filter frame will accept 20"x20" standard 1" filter. Aluminum egg crate grid 1/2"x1/2"x1/2" in hinged extruded aluminum U frame, swings in and out of fixed frame for access to 20" x 20" filter, by others.

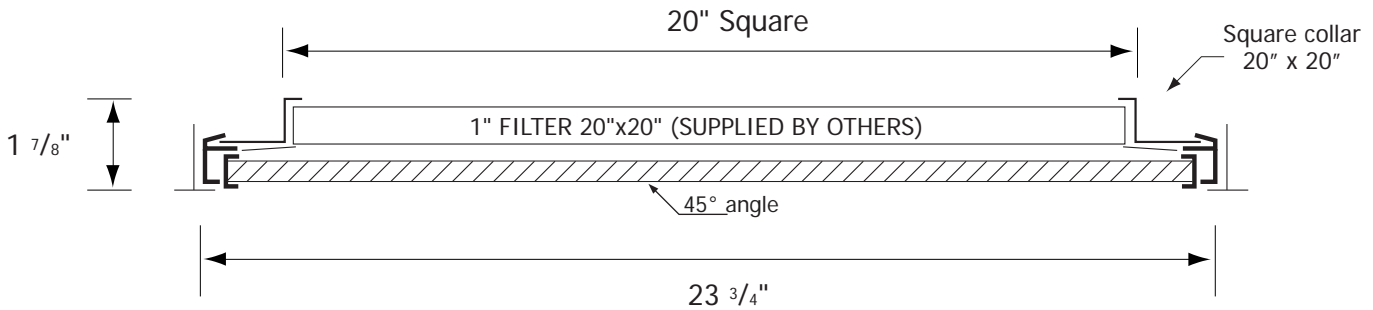
Grid core: 45° Angled Eggcrate Core

Finish: Powder paint coating - white.

Mounting: T-bar Lay-in ceiling.



ERTF5



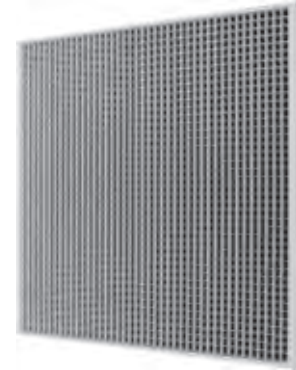
Finish	
<input type="checkbox"/> /W White <small>(default)</small>	<input type="checkbox"/> Custom <small>(please specify)</small>



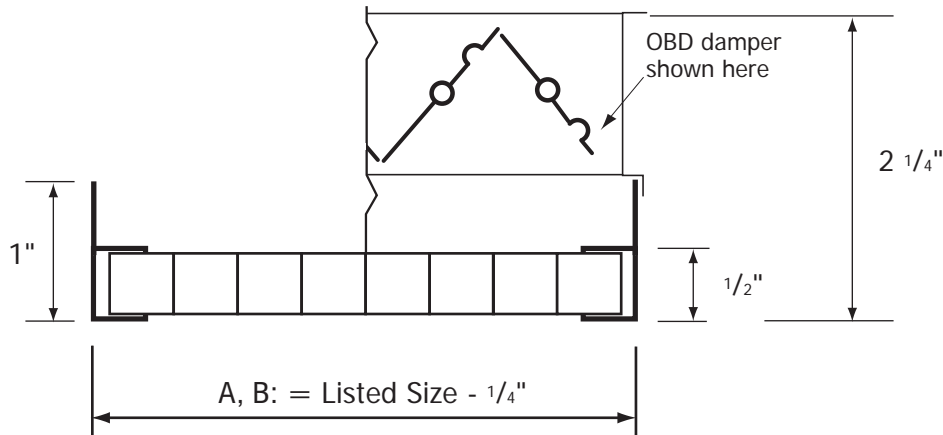
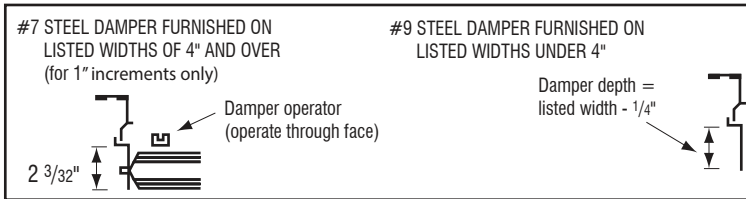
Schedule type: _____
Job: _____
Architect: _____
Engineer: _____
Contractor: _____

Eggcrate Return Grille with "U" Frame

Material: All aluminium construction.
Mounting: T-bar lay-in.
 No mounting holes.
Grid core: Aluminum $\frac{1}{2}$ " x $\frac{1}{2}$ " x $\frac{1}{2}$ ".



ERU / ERU7
(ERU 2424 shown here)



✓	Model #	Face Dim. A x B	Neck
	ERU 1212	11 $\frac{3}{4}$ " x 11 $\frac{3}{4}$ "	12" x 12"
	ERU 2412	23 $\frac{3}{4}$ " x 11 $\frac{3}{4}$ "	24" x 12"
	ERU 2424	23 $\frac{3}{4}$ " x 23 $\frac{3}{4}$ "	24" x 24"
	ERU 4812	47 $\frac{3}{4}$ " x 11 $\frac{3}{4}$ "	48" x 12"
	ERU 4824	47 $\frac{3}{4}$ " x 23 $\frac{3}{4}$ "	48" x 24"
	ERU7 1212	11 $\frac{3}{4}$ " x 11 $\frac{3}{4}$ "	12" x 12"
	ERU7 2412	23 $\frac{3}{4}$ " x 11 $\frac{3}{4}$ "	24" x 12"
	ERU7 2424	23 $\frac{3}{4}$ " x 23 $\frac{3}{4}$ "	24" x 24"
	ERU7 4812	47 $\frac{3}{4}$ " x 11 $\frac{3}{4}$ "	48" x 12"
	ERU7 4824	47 $\frac{3}{4}$ " x 23 $\frac{3}{4}$ "	48" x 24"

Custom dimensions available upon request.

Finish	
<input type="checkbox"/> /W White <small>(default)</small>	<input type="checkbox"/> Custom <small>(please specify)</small>

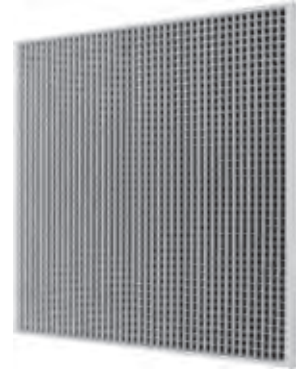


Schedule type: _____
Job: _____
Architect: _____
Engineer: _____
Contractor: _____

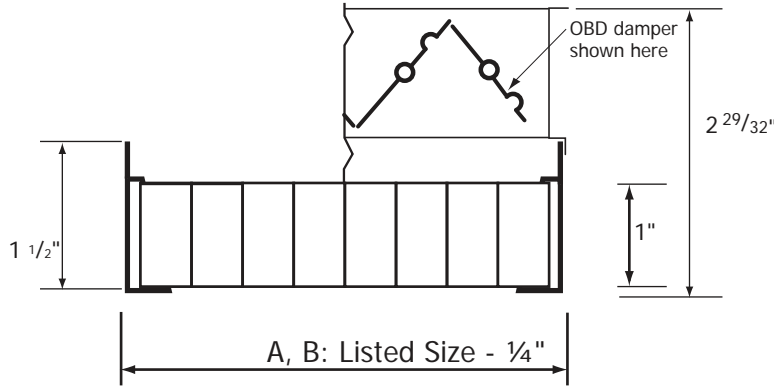
SUBMITTAL SHEET

Eggcrate Return Grille with "U" Frame, 1" thick core

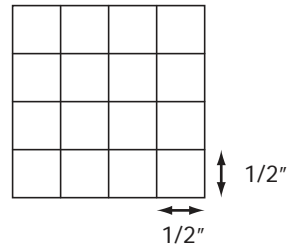
- Material:** All aluminium construction.
- Mounting:** T-bar lay-in.
No mounting holes.
- Grid core:** Aluminum 1/2" x 1/2" x 1".



ERU1 / ERU17
(ERU 2424 shown here)

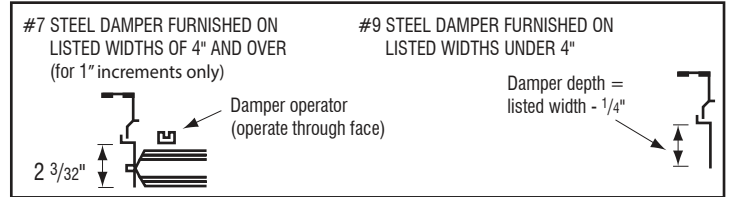


Eggcrate core



✓	Model #	Face Dim. A x B	Neck
	ERU1 1212	11 3/4" x 11 3/4"	12" x 12"
	ERU1 2412	23 3/4" x 11 3/4"	24" x 12"
	ERU1 2424	23 3/4" x 23 3/4"	24" x 24"
	ERU1 4812	47 3/4" x 11 3/4"	48" x 12"
	ERU1 4824	47 3/4" x 23 3/4"	48" x 24"
	ERU17 1212	11 3/4" x 11 3/4"	12" x 12"
	ERU17 2412	23 3/4" x 11 3/4"	24" x 12"
	ERU17 2424	23 3/4" x 23 3/4"	24" x 24"
	ERU17 4812	47 3/4" x 11 3/4"	48" x 12"
	ERU17 4824	47 3/4" x 23 3/4"	48" x 24"

Custom dimensions available upon request.



Panel Option for T-bar lay-in Ceiling	
Steel (WxH)	Aluminum (WxH)
<input type="checkbox"/> -X11 (12"x12")	<input type="checkbox"/> -Y11 (12"x12")
<input type="checkbox"/> -X21 (24"x12")	<input type="checkbox"/> -Y21 (24"x12")
<input type="checkbox"/> -X22 (24"x24")	<input type="checkbox"/> -Y22 (24"x24")
<input type="checkbox"/> -X41 (48"x12")	<input type="checkbox"/> -Y41 (48"x12")
<input type="checkbox"/> -X42 (48"x24")	<input type="checkbox"/> -Y42 (48"x24")

No fastening options available

Finish	
<input type="checkbox"/> /W White (default)	<input type="checkbox"/> Custom (please specify)



Schedule type: _____

Job: _____

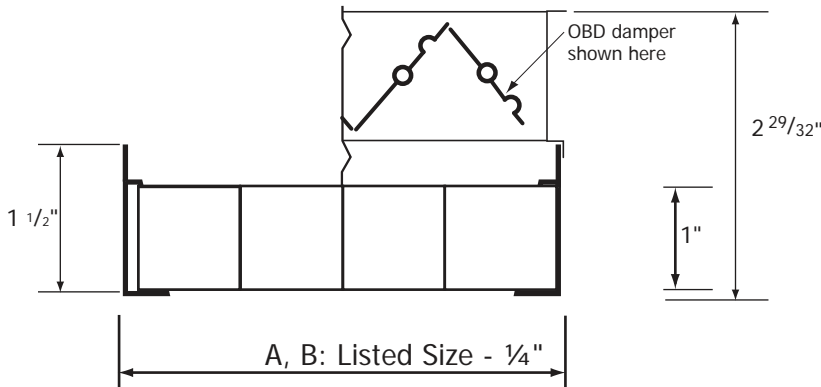
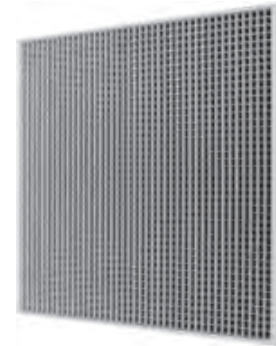
Architect: _____

Engineer: _____

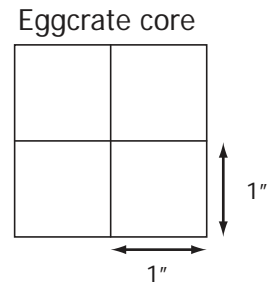
Contractor: _____

Eggcrate Return Grille with "U" Frame, 1" square cell size

Material: All aluminium construction.
Mounting: T-bar lay-in.
 No mounting holes.
Grid core: Aluminum 1" x 1" x 1".

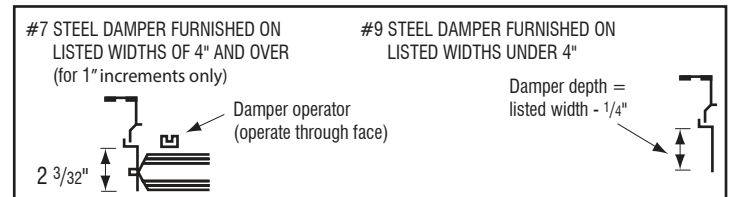


ERU3 / ERU37
(ERU3 2424 shown here)



✓	Model #	Face Dim. A x B	Neck
	ERU3 1212	11 ³ / ₄ " x 11 ³ / ₄ "	12" x 12"
	ERU3 2412	23 ³ / ₄ " x 11 ³ / ₄ "	24" x 12"
	ERU3 2424	23 ³ / ₄ " x 23 ³ / ₄ "	24" x 24"
	ERU3 4812	47 ³ / ₄ " x 11 ³ / ₄ "	48" x 12"
	ERU3 4824	47 ³ / ₄ " x 23 ³ / ₄ "	48" x 24"
	ERU37 1212	11 ³ / ₄ " x 11 ³ / ₄ "	12" x 12"
	ERU37 2412	23 ³ / ₄ " x 11 ³ / ₄ "	24" x 12"
	ERU37 2424	23 ³ / ₄ " x 23 ³ / ₄ "	24" x 24"
	ERU37 4812	47 ³ / ₄ " x 11 ³ / ₄ "	48" x 12"
	ERU37 4824	47 ³ / ₄ " x 23 ³ / ₄ "	48" x 24"

Custom dimensions available upon request.



Panel Option for T-bar lay-in Ceiling		Steel (WxH)	Aluminum (WxH)
<p>No fastening options available</p>	<input type="checkbox"/>	-X1212	<input type="checkbox"/> -Y1212
	<input type="checkbox"/>	-X2412	<input type="checkbox"/> -Y2412
	<input type="checkbox"/>	-X2424	<input type="checkbox"/> -Y2424
	<input type="checkbox"/>	-X4812	<input type="checkbox"/> -Y4812
	<input type="checkbox"/>	-X4824	<input type="checkbox"/> -Y4824

Finish	
<input type="checkbox"/> /W White (default)	<input type="checkbox"/> Custom (please specify)

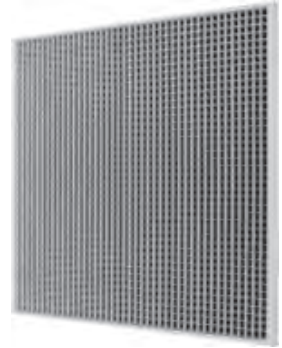


Schedule type: _____
 Job: _____
 Architect: _____
 Engineer: _____
 Contractor: _____

SUBMITTAL SHEET

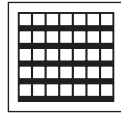
Eggcrate Return Grille with "U" Frame 45° Angled Eggcrate

Material: All aluminium construction.
Mounting: T-bar lay-in.
 No mounting holes.
Grid core: Aluminum 1/2" x 1/2" x 1/2".
 45° Angled Eggcrate Core



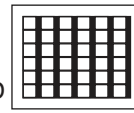
Horizontal Air Flow (Standard)

- ERU5
- ERU57 with OBD

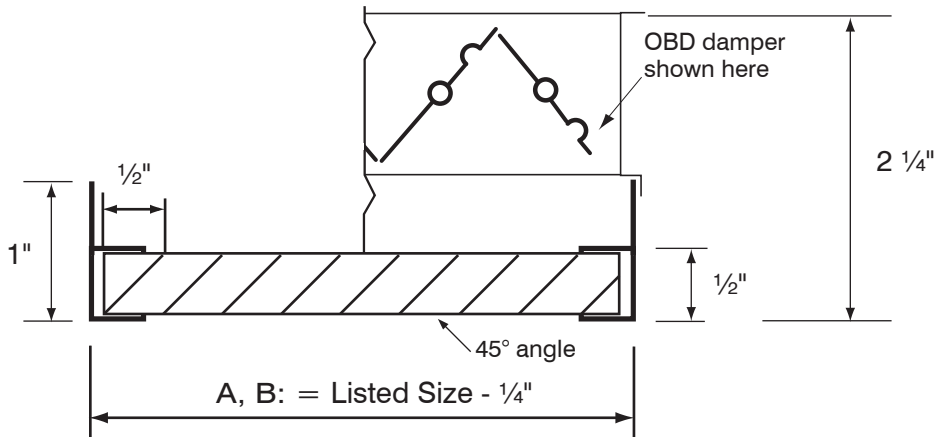


Vertical Face Bars

- ERU5-V
- ERU57-V with OBD



ERU5 / ERU57
 (ERU5 2424 shown here)



✓	Model #	Face Dim. A x B	Neck
	ERU5 1212	11 3/4" x 11 3/4"	12" x 12"
	ERU5 2412	23 3/4" x 11 3/4"	24" x 12"
	ERU5 2424	23 3/4" x 23 3/4"	24" x 24"
	ERU5 4812	47 3/4" x 11 3/4"	48" x 12"
	ERU5 4824	47 3/4" x 23 3/4"	48" x 24"
	ERU57 1212	11 3/4" x 11 3/4"	12" x 12"
	ERU57 2412	23 3/4" x 11 3/4"	24" x 12"
	ERU57 2424	23 3/4" x 23 3/4"	24" x 24"
	ERU57 4812	47 3/4" x 11 3/4"	48" x 12"
	ERU57 4824	47 3/4" x 23 3/4"	48" x 24"

Custom dimensions available upon request.

#7 STEEL DAMPER FURNISHED ON LISTED WIDTHS OF 4" AND OVER (for 1" increments only)	#9 STEEL DAMPER FURNISHED ON LISTED WIDTHS UNDER 4"
Damper operator (operate through face)	

Finish	
<input type="checkbox"/> /W White (default)	<input type="checkbox"/> /C Custom (please specify) _____

Schedule type: _____

Job: _____

Architect: _____

Engineer: _____

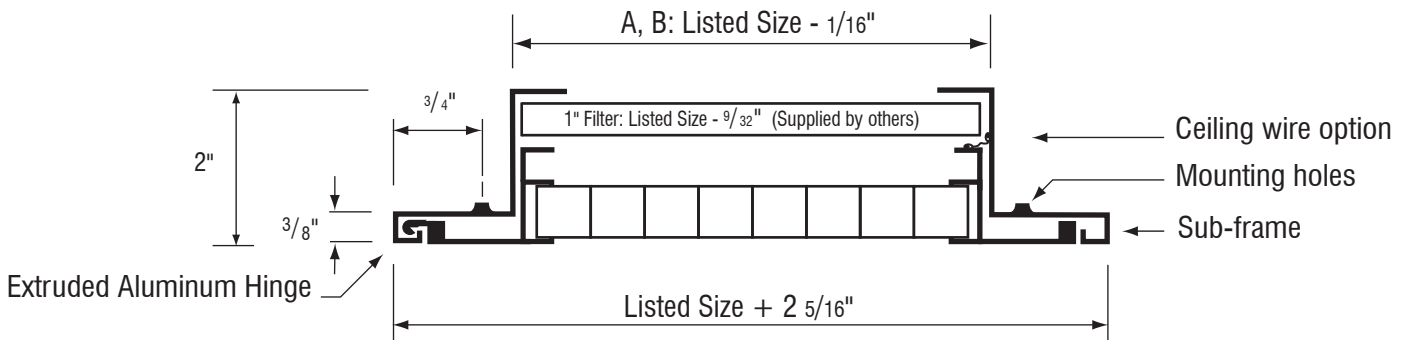
Contractor: _____

Eggcrate Filter Return Grille for Surface Mount



FERRE

- Material:** All aluminium construction
Hinged extrusion on one end,
easy pry-open or push-close clip
- Mounting:** Surface mounting
Countersunk mounting holes on sub-frame.
- Grid core:** Aluminum 1/2" x 1/2" x 1/2"
- Filter:** 1" filter: Listed size - 9/32" (supplied by others)



Options		
<input type="checkbox"/> -CW Security Ceiling Wire	<input type="checkbox"/> -DS Debris (Bird) Screen	<input type="checkbox"/> -IS Insect Screen

Size limits	Width A		Height B	
	in	mm	in	mm
Minimum	4	102	4	102
Maximum	48	1219	48	1219

Mounting Options			
<input type="checkbox"/> -C (Default) Concealed Clip Easy pry-open push-close clip	<input type="checkbox"/> -S Screen Tabs 	<input type="checkbox"/> -TS Thumb Screw 	<input type="checkbox"/> -CS Countersunk Screw

Finish		
<input type="checkbox"/> /W White (Default)	<input type="checkbox"/> /M Mill	<input type="checkbox"/> /C Custom (Please Specify)



Panel Option for T-bar lay-in Ceiling				
W	Steel (WxH)		Aluminum (WxH)	
	H	<input type="checkbox"/> -X1212	<input type="checkbox"/> -Y1212	<input type="checkbox"/> -X2412
	<input type="checkbox"/> -X2424	<input type="checkbox"/> -Y2424	<input type="checkbox"/> -X4824	<input type="checkbox"/> -Y4824
	<input type="checkbox"/> -X2020	<input type="checkbox"/> -Y2020		

No mounting options available

Schedule type: _____

Job: _____

Architect: _____

Engineer: _____

Contractor: _____

SUBMITTAL SHEET

Egg Crate Filter Return Grille for Surface Mount 45° Angled Egg Crate

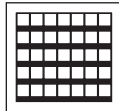
- Material:** All aluminium construction
Hinged extrusion on one end,
easy pry-open or push-close clip
- Mounting:** Surface mounting
Countersunk mounting holes on sub-frame.
- Grid core:** Aluminum 1/2" x 1/2" x 1/2" - 45° Angled Eggcrate Core
- Filter:** 1" filter: Listed size - 9/32" (supplied by others)



FERÉ5

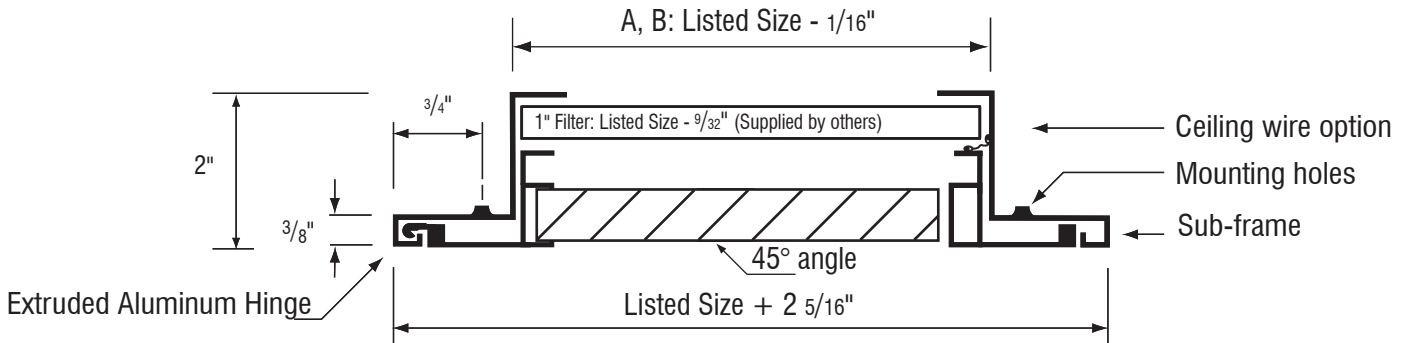
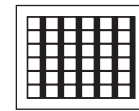
Horizontal Air Flow (Standard)

FERÉ5



Vertical Air Flow

FERÉ5-V



Options

<input type="checkbox"/> -CW Security Ceiling Wire	<input type="checkbox"/> -DS Debris (Bird) Screen	<input type="checkbox"/> -IS Insect Screen
--	---	--

Size limits	Width A		Height B	
	in	mm	in	mm
Minimum	4	102	4	102
Maximum	48	1219	48	1219

Panel Option for T-bar lay-in Ceiling

W	H	Steel (WxH)		Aluminum (WxH)	
		<input type="checkbox"/> -X1212	<input type="checkbox"/> -X2412	<input type="checkbox"/> -Y1212	<input type="checkbox"/> -Y2412
		<input type="checkbox"/> -X2424	<input type="checkbox"/> -X4824	<input type="checkbox"/> -Y2424	<input type="checkbox"/> -Y4824
		<input type="checkbox"/> -X2020		<input type="checkbox"/> -Y2020	

No mounting options available

Mounting Options

<input type="checkbox"/> -C (Default) Concealed Clip Easy pry-open push-close clip	<input type="checkbox"/> -S Screen Tabs	<input type="checkbox"/> -TS Thumb Screw	<input type="checkbox"/> -CS Countersunk Screw
---	---	--	--

Finish

<input type="checkbox"/> /W White (Default)	<input type="checkbox"/> /M Mill	<input type="checkbox"/> /C Custom (Please Specify)
---	--	--



Schedule type: _____

Job: _____

Architect: _____

Engineer: _____

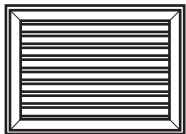
Contractor: _____

Filter Return Grille for Surface Mount

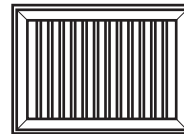
- Material:** Aluminum frame and fins
Hinged extrusion on one end,
easy pry-open or push-close clip
- Mounting:** Surface mounting
Countersunk mounting holes on sub-frame.
- Grille core:** Fin spacing: 2/3"
- Filter:** 1" filter: Listed size - 9/32" (supplied by others)



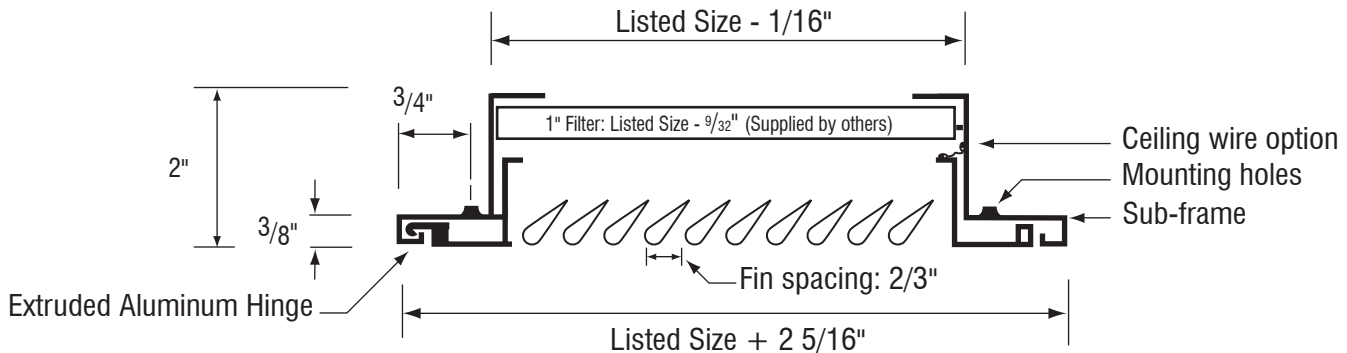
FGAA



FGAA



FGAA-V



Filter Options			Fins
<input type="checkbox"/> -F0 No Filter N/A with -C	<input type="checkbox"/> -F2 2" Filter	<input type="checkbox"/> -F4 4" Filter	<input type="checkbox"/> -FB 0° deflection

Options		
<input type="checkbox"/> -CW Security Ceiling Wire	<input type="checkbox"/> -DS Debris (Bird) Screen	<input type="checkbox"/> -IS Insect Screen

Panel Option for T-bar lay-in Ceiling		
W	Steel (WxH)	Aluminum (WxH)
	<input type="checkbox"/> -X1212	<input type="checkbox"/> -Y1212
	<input type="checkbox"/> -X2412	<input type="checkbox"/> -Y2412
	<input type="checkbox"/> -X2424	<input type="checkbox"/> -Y2424
	<input type="checkbox"/> -X4824	<input type="checkbox"/> -Y4824
	<input type="checkbox"/> -X2020	<input type="checkbox"/> -Y2020

No mounting options available

Latching Options			
<input type="checkbox"/> -C (Default) Concealed Clip Easy pry-open push-close clip	<input type="checkbox"/> -S Screen Tabs	<input type="checkbox"/> -TS Thumb Screw	<input type="checkbox"/> -CS Countersunk Screw

Finish		
<input type="checkbox"/> /W White (Default)	<input type="checkbox"/> /M Mill	<input type="checkbox"/> Custom (Please Specify)



Schedule type: _____

Job: _____

Architect: _____

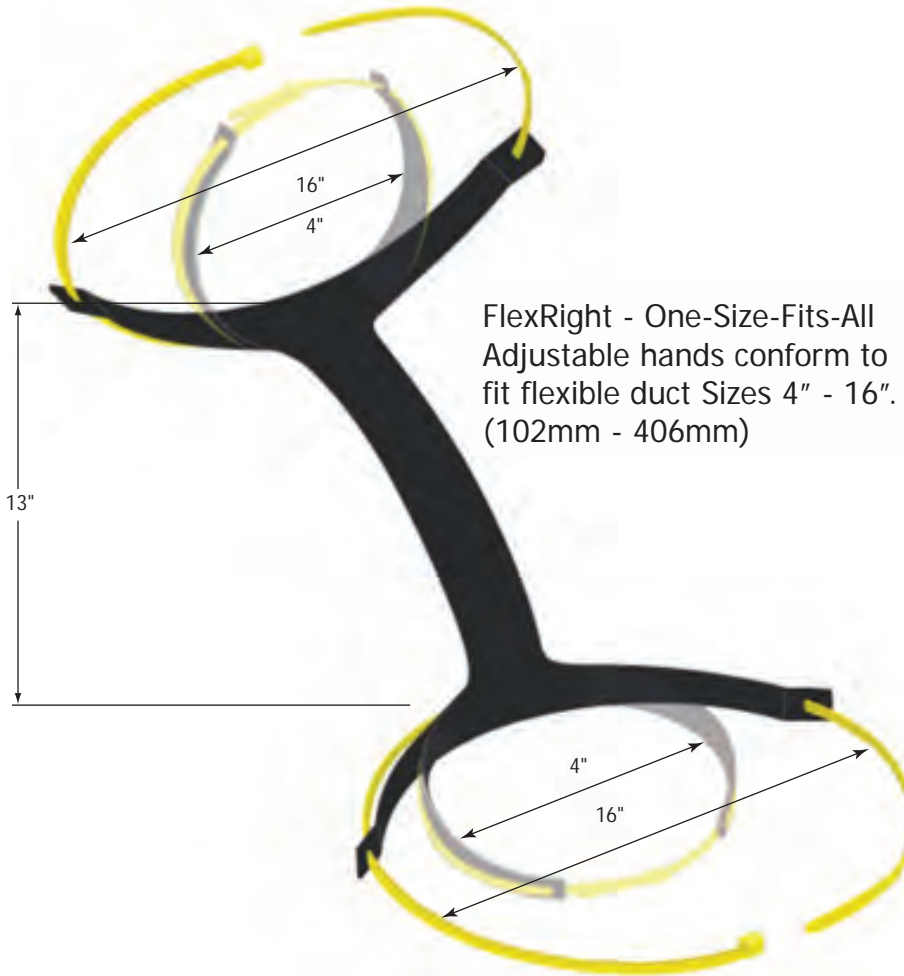
Engineer: _____

Contractor: _____

FlexRight

Radius forming brace for flexible ducts.

- Material:** 100% recycled, UL listed materials.
- Mounting:** Install on diffuser collar and round flex duct.
Fits collars and flex ducts 4" - 16".



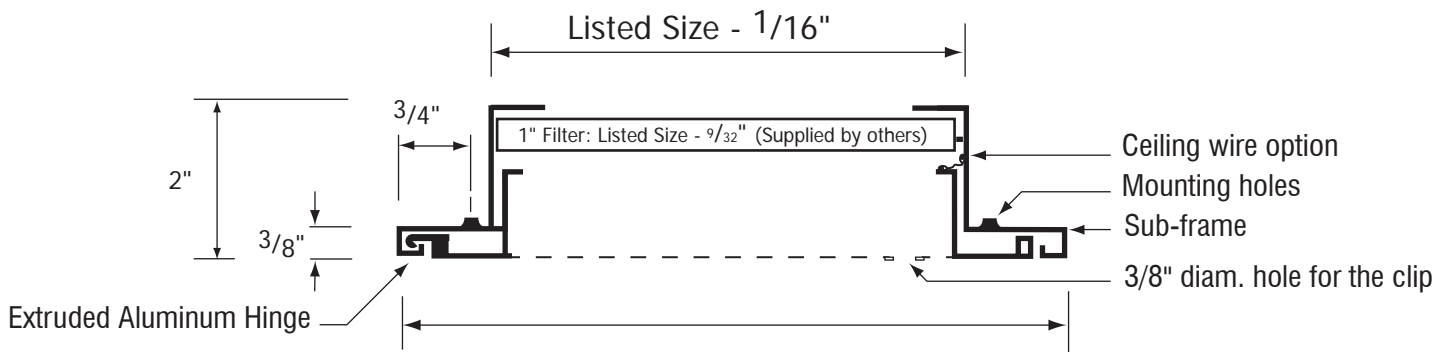
Schedule type: _____
Job: _____
Architect: _____
Engineer: _____
Contractor: _____

Perforated Filter Return Grille for Surface Mount

- Material:** Aluminum frame
Steel perforated face with 3/16" diam. holes
Hinged extrusion on one end,
easy pry-open or push-close clip
- Mounting:** Surface mounting
Countersunk mounting holes on sub-frame.
- Filter:** 1" filter: Listed size - 9/32" (supplied by others)



FPRE



Filter	
-F2 2" Filter	-F4 4" Filter

Options		
-CW Security Ceiling Wire	-DS Debris (Bird) Screen	-IS Insect Screen

Panel Option for T-bar lay-in Ceiling		
	Steel (WxH)	Aluminum (WxH)
	<input type="checkbox"/> -X1212	<input type="checkbox"/> -Y1212
	<input type="checkbox"/> -X2412	<input type="checkbox"/> -Y2412
	<input type="checkbox"/> -X2424	<input type="checkbox"/> -Y2424
	<input type="checkbox"/> -X4824	<input type="checkbox"/> -Y4824
	<input type="checkbox"/> -X2020	<input type="checkbox"/> -Y2020

No mounting options available

Mounting Options			
-C (Default) Concealed Clip Easy pry-open push-close clip	-S Screen Tabs 	-TS Thumb Screw 	-CS Countersunk Screw

Finish		
<input type="checkbox"/> /W White (Default)	<input type="checkbox"/> /M Mill	<input type="checkbox"/> /C Custom (Please Specify)



Schedule type: _____

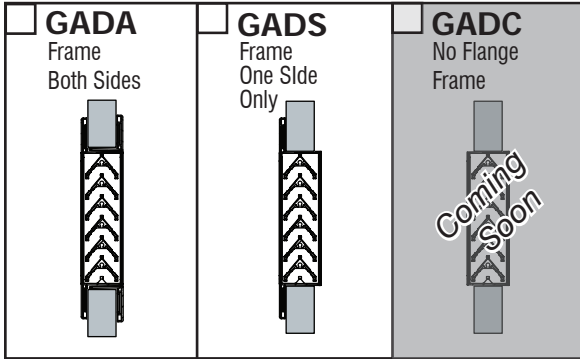
Job: _____

Architect: _____

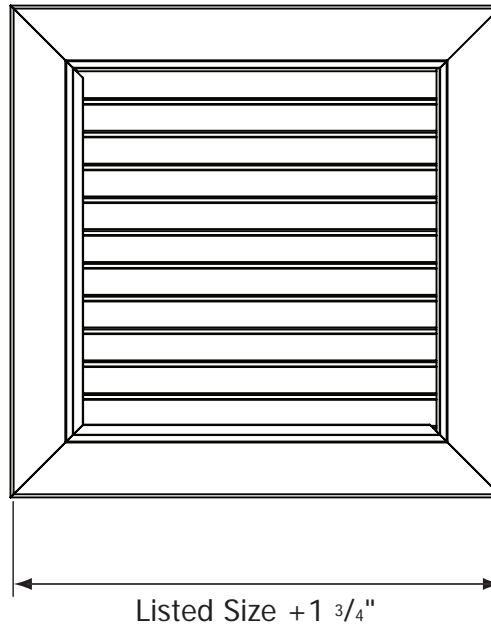
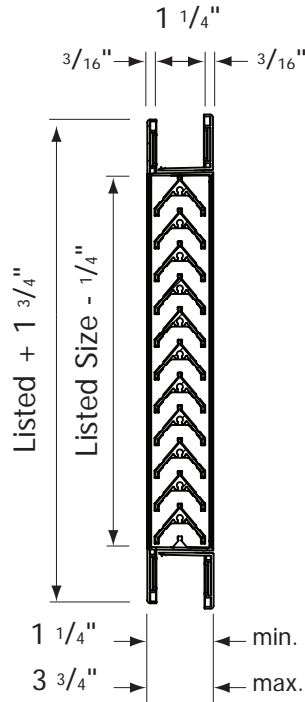
Engineer: _____

Contractor: _____

Sight Proof Heavy Duty Aluminum Transfer Air Door Grille



GADA



Finish		
<input type="checkbox"/> /W White <small>(default)</small>	<input type="checkbox"/> /M Mill	<input type="checkbox"/> Custom <small>(please specify)</small>

Schedule type: _____

Job: _____

Architect: _____

Engineer: _____

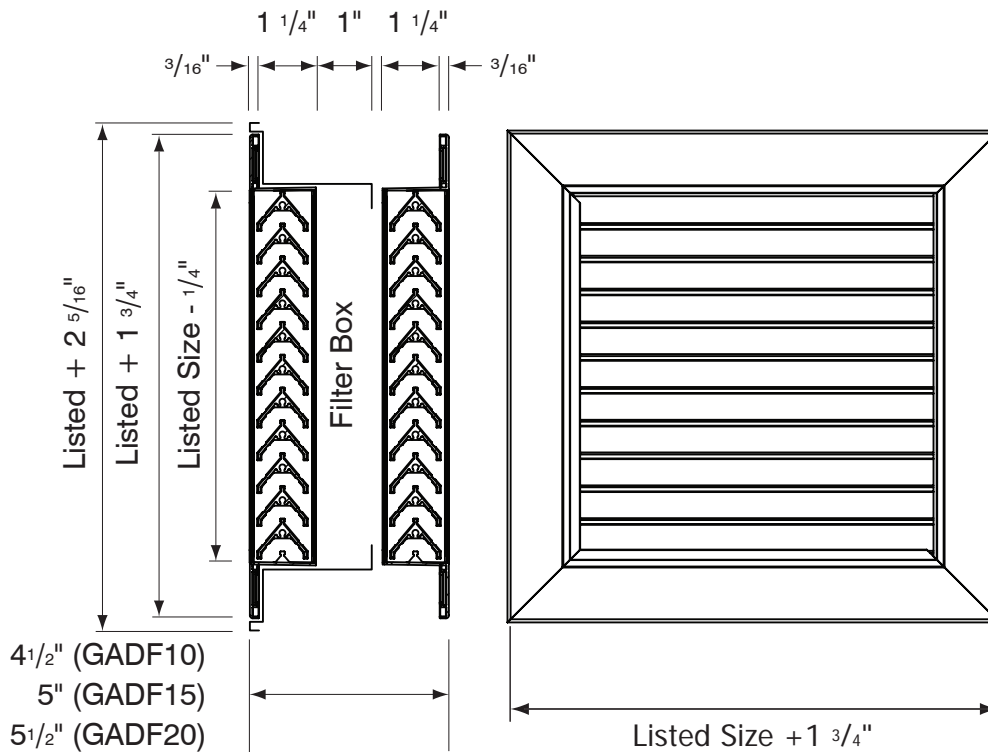
Contractor: _____

Filter Model GADF

- GADF10 1" filter
- GADF15 1.5" filter
- GADF20 2" filter



GADF
(Filter Door Grille)



Finish		
<input type="checkbox"/> /W White <small>(default)</small>	<input type="checkbox"/> /M Mill	<input type="checkbox"/> Custom <small>(please specify)</small>

Schedule type: _____

Job: _____

Architect: _____

Engineer: _____

Contractor: _____

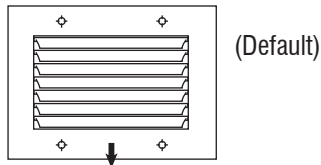
SUBMITTAL SHEET

1 Way Adjustable Curved Blade Supply Grille Recessed Blades

- Material:** Extruded aluminum with mechanically fastened corners.
- Mounting:** Drywall or any surface mounting. Countersunk mounting holes on frame.
- Air Pattern:** 90° Diffusion.
Adjustable blades 2/3" spacing.

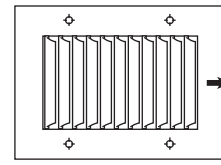


GCB10



Standard discharge pattern (Vertical)

- GCB10-WV**
- GCB17-WV With OBD**



Alternate discharge pattern (Horizontal)

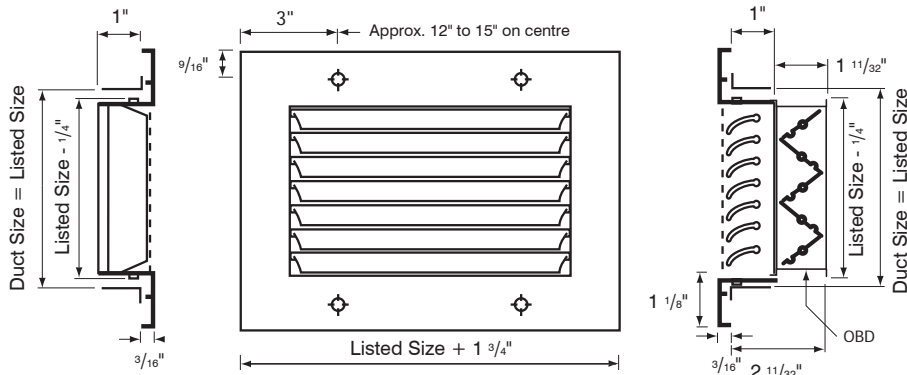
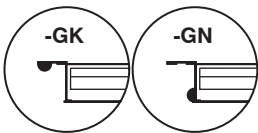
- GCB10-WH**
- GCB17-WH With OBD**

Blade Deflection Options

- Adjustable Blades (Default) -AB**
- Fixed Blades -FB**

Options

- Supplied w/sub frame -SF**
- Debris (Bird) Screen -DS**
- Insect Screen -IS**
- Flange Gasket -GK**
- Neck Gasket -GN**
- One Piece -U**



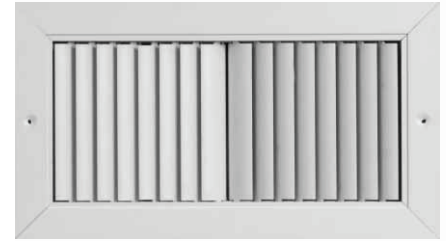
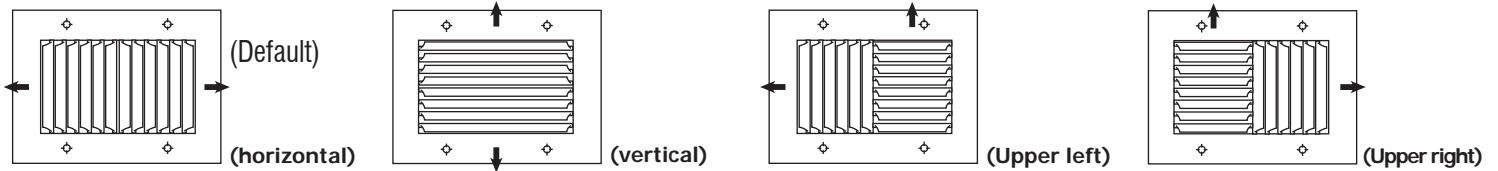
Finish				
<input type="checkbox"/> /W White (default)	<input type="checkbox"/> /B Brushed Aluminium	<input type="checkbox"/> /M Mill Finish	<input type="checkbox"/> /L Brushed and Lacquered	<input type="checkbox"/> Custom (Please Specify)

Panel Option for T-bar lay-in Ceiling		
	Steel (WxH)	Aluminum (WxH)
	<input type="checkbox"/> -X1212	<input type="checkbox"/> -Y1212
	<input type="checkbox"/> -X1224	<input type="checkbox"/> -Y1224
	<input type="checkbox"/> -X2412	<input type="checkbox"/> -Y2412
	<input type="checkbox"/> -X2424	<input type="checkbox"/> -Y2424
	<input type="checkbox"/> -X2448	<input type="checkbox"/> -Y2448
	<input type="checkbox"/> -X4824	<input type="checkbox"/> -Y4824
No fastening options available	<input type="checkbox"/> -X2020	<input type="checkbox"/> -Y2020

Fastening Method		
<input type="checkbox"/> -1 No Fastening	<input type="checkbox"/> -2 Spring clip	<input type="checkbox"/> -3 Screw holes (Default)
Schedule type: _____		
Job: _____		
Architect: _____		
Engineer: _____		
Contractor: _____		

2 Way Adjustable Curved Blade Supply Grille Recessed Blades

- Material:** Extruded aluminum with mechanically fastened corners.
- Mounting:** Drywall or any surface mounting. Countersunk mounting holes on frame.
- Air Pattern:** 90° or 180° Diffusion.
Adjustable blades 2/3" spacing.


GCB20


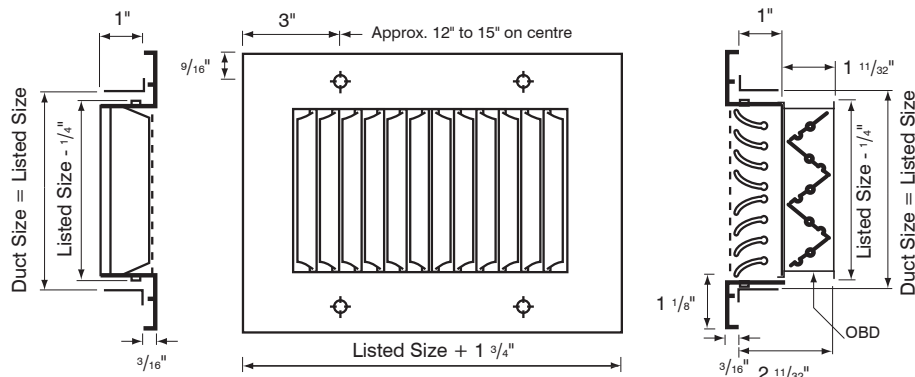
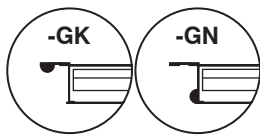
- | | | | |
|--|--|--|--|
| Standard discharge pattern | Alternate discharge pattern | Alternate discharge pattern | Alternate discharge pattern |
| <input type="checkbox"/> GCB20-WOH | <input type="checkbox"/> GCB20-WOV | <input type="checkbox"/> GCB20-WUL | <input type="checkbox"/> GCB20-WUR |
| <input type="checkbox"/> GCB27-WOH With OBD | <input type="checkbox"/> GCB27-WOV With OBD | <input type="checkbox"/> GCB27-WUL With OBD | <input type="checkbox"/> GCB27-WUR With OBD |

Blade Deflection Options

- Adjustable Blades (default) -AB
- Fixed Blades -FB

Options

- Supplied w/sub frame -SF
- Debris (Bird) Screen -DS
- Insect Screen -IS
- Flange Gasket -GK
- Neck Gasket -GN
- One Piece -U



Finish

<input type="checkbox"/> /W White (default)	<input type="checkbox"/> /B Brushed Aluminium	<input type="checkbox"/> /M Mill Finish	<input type="checkbox"/> /L Brushed and Lacquered	<input type="checkbox"/> Custom (Please Specify)
--	--	--	--	---

Panel Option for T-bar lay-in Ceiling

	Steel (WxH)	Aluminum (WxH)
<input type="checkbox"/> -X1212	<input type="checkbox"/> -Y1212	
<input type="checkbox"/> -X1224	<input type="checkbox"/> -Y1224	
<input type="checkbox"/> -X2412	<input type="checkbox"/> -Y2412	
<input type="checkbox"/> -X2424	<input type="checkbox"/> -Y2424	
<input type="checkbox"/> -X2448	<input type="checkbox"/> -Y2448	
<input type="checkbox"/> -X4824	<input type="checkbox"/> -Y4824	
<input type="checkbox"/> -X2020	<input type="checkbox"/> -Y2020	

No fastening options available

Fastening Method

<input type="checkbox"/> -1 No Fastening	<input type="checkbox"/> -2 Spring clip	<input type="checkbox"/> -3 Screw holes (Default)
--	---	---

Schedule type: _____

Job: _____

Architect: _____

Engineer: _____

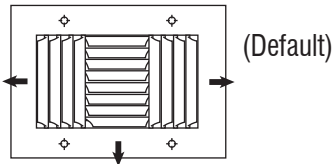
Contractor: _____

3 Way Adjustable Curved Blade Supply Grille Recessed Blades

- Material:** Extruded aluminum with mechanically fastened corners.
- Mounting:** Drywall or any surface mounting. Countersunk mounting holes on frame.
- Air Pattern:** 270° Diffusion.
Adjustable blades 2/3" spacing.

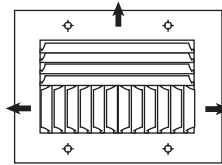


GCB30



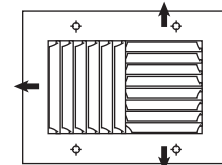
Standard discharge pattern

- GCB30-WS**
 GCB37-WS With OBD



Alternate discharge pattern (long)

- GCB30-WL**
 GCB37-WL With OBD



Alternate discharge pattern

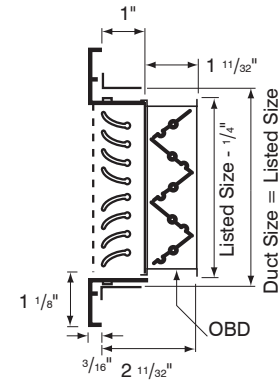
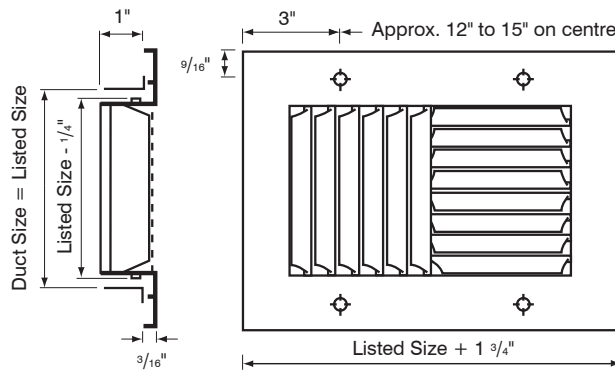
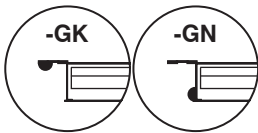
- GCB30-WA**
 GCB37-WA With OBD

Blade Deflection Options

- Adjustable Blades (default) -AB**
 Fixed Blades -FB

Options

- Supplied w/sub frame -SF**
 Debris (Bird) Screen -DS
 Insect Screen -IS
 Flange Gasket -GK
 Neck Gasket -GN
 One Piece -U



Finish

<input type="checkbox"/> /W White (default)	<input type="checkbox"/> /B Brushed Aluminium	<input type="checkbox"/> /M Mill Finish	<input type="checkbox"/> /L Brushed and Lacquered	<input type="checkbox"/> Custom (Please Specify)
--	--	--	--	--

Panel Option for T-bar lay-in Ceiling

	Steel (WxH)	Aluminum (WxH)
	<input type="checkbox"/> -X1212	<input type="checkbox"/> -Y1212
	<input type="checkbox"/> -X1224	<input type="checkbox"/> -Y1224
	<input type="checkbox"/> -X2412	<input type="checkbox"/> -Y2412
	<input type="checkbox"/> -X2424	<input type="checkbox"/> -Y2424
	<input type="checkbox"/> -X2448	<input type="checkbox"/> -Y2448
	<input type="checkbox"/> -X4824	<input type="checkbox"/> -Y4824
No fastening options available	<input type="checkbox"/> -X2020	<input type="checkbox"/> -Y2020

Fastening Method

<input type="checkbox"/> -1 No Fastening	<input type="checkbox"/> -2 Spring clip	<input type="checkbox"/> -3 Screw holes (Default)

Schedule type: _____

Job: _____

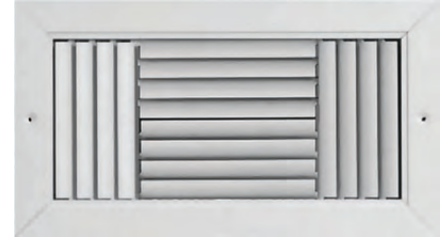
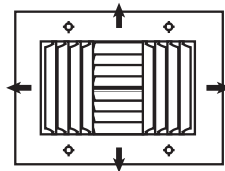
Architect: _____

Engineer: _____

Contractor: _____

4 Way Adjustable Curved Blade Supply Grille Recessed Blades

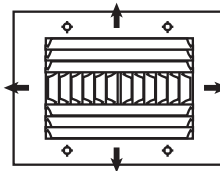
- Material:** Extruded aluminum with mechanically fastened corners.
- Mounting:** Drywall or any surface mounting. Countersunk mounting holes on frame.
- Air Pattern:** 360° Diffusion.
Adjustable blades 2/3" spacing.


GCB40


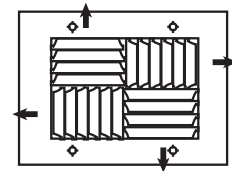
(Default)

Standard Discharge Pattern

- GCB40-WS
- GCB47-WS With OBD


Alternate Discharge Pattern (long)

- GCB40-WL
- GCB47-WL With OBD


Alternate Discharge Pattern

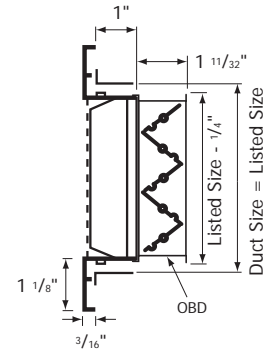
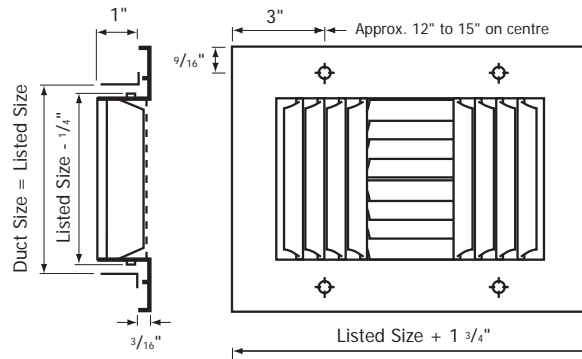
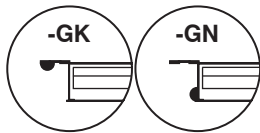
- GCB40-WA
- GCB47-WA With OBD

Blade Deflection Options

- Adjustable Blades (default) -AB
- Fixed Blades -FB

Options

- Supplied w/sub frame -SF
- Debris (Bird) Screen -DS
- Insect Screen -IS
- Flange Gasket -GK
- Neck Gasket -GN
- One Piece -U


Finish

<input type="checkbox"/> /W White (default)	<input type="checkbox"/> /B Brushed Aluminium	<input type="checkbox"/> /M Mill Finish	<input type="checkbox"/> /L Brushed and Lacquered	<input type="checkbox"/> Custom (Please Specify)
--	--	--	--	---

Panel Option for T-bar lay-in Ceiling

	Steel (WxH)	Aluminum (WxH)
	<input type="checkbox"/> -X1212	<input type="checkbox"/> -Y1212
	<input type="checkbox"/> -X1224	<input type="checkbox"/> -Y1224
	<input type="checkbox"/> -X2412	<input type="checkbox"/> -Y2412
	<input type="checkbox"/> -X2424	<input type="checkbox"/> -Y2424
	<input type="checkbox"/> -X2448	<input type="checkbox"/> -Y2448
	<input type="checkbox"/> -X4824	<input type="checkbox"/> -Y4824
No fastening options available	<input type="checkbox"/> -X2020	<input type="checkbox"/> -Y2020

Fastening Method

<input type="checkbox"/> -1 No Fastening	<input type="checkbox"/> -2 Spring clip	<input type="checkbox"/> -3 Screw holes (Default)
--	---	---

Schedule type: _____

Job: _____

Architect: _____

Engineer: _____

Contractor: _____

Single Deflection Spiral Duct Grille Adjustable Air Pattern

Material: Aluminum construction.
Adjustable blades.
Finish: Powder paint coating - white.
Mounting: Screw holes mounting.
Spacing: 2/3" Blade Spacing



GDA18

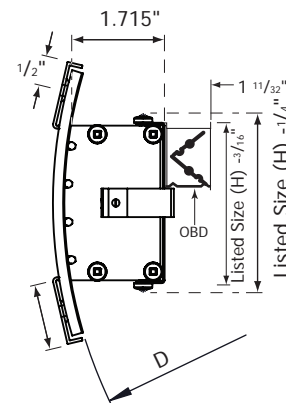
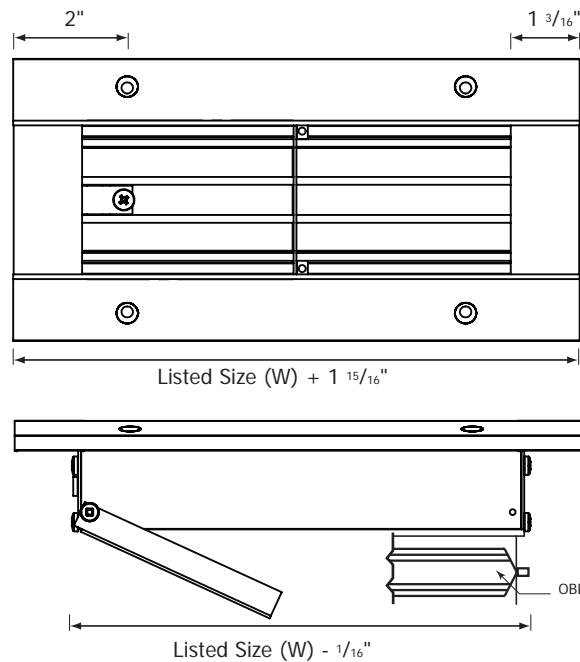
Horizontal Face Blades

- GDA10-H** Aluminum Fins
- GDA17-H** Steel Opposed Blade Damper
- GDA18-H** Aluminum Fins with Air Scoop

Vertical Face Blades

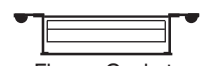
- GDA10-V** Aluminum Fins
- GDA17-V** Steel Opposed Blade Damper
- GDA18-V** Aluminum Fins with Air Scoop

Nice feature: Fins follow the curve on the face of the grille.



Options

-GK (1/2" x 1/2" thick)



Flange Gasket
(included over 20" D)



Duct D	H= List Height					
	3"	4"	6"	8"	10"	12"
6"						
8"						
10"						
12"						
14"						
16"						
18"						
20"						
Over 20"						

Finish

/W White (default) /M Mill Finish Custom (please specify)

Schedule type: _____

Job: _____

Architect: _____

Engineer: _____

Contractor: _____

Double Deflection Spiral Duct Grille Adjustable Air Pattern

Material: Aluminum construction.
 Adjustable blades.
Finish: Powder paint coating - white.
Mounting: Screw holes mounting.
Spacing: 2/3" Blade Spacing


GDA28

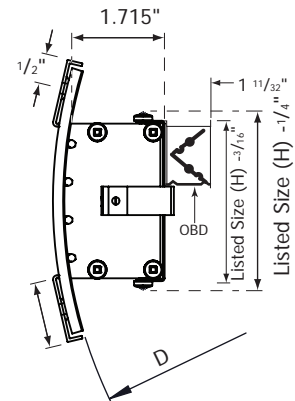
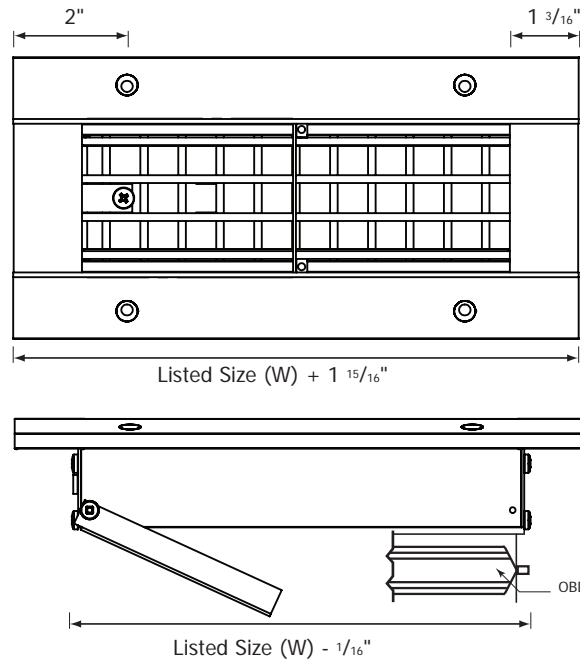
Horizontal Face Blades

- GDA20-H** Aluminum Fins
- GDA27-H** Steel Opposed Blade Damper
- GDA28-H** Aluminum Fins with Air Scoop

Vertical Face Blades

- GDA20-V** Aluminum Fins
- GDA27-V** Steel Opposed Blade Damper
- GDA28-V** Aluminum Fins with Air Scoop

Nice feature: Fins follow the curve on the face of the grille.



Options	
<input type="checkbox"/> -GK	(1/2" x 1/2" thick)
Flange Gasket (included over 20" D)	



Duct D	H= List Height					
	3"	4"	6"	8"	10"	12"
6"						
8"						
10"						
12"						
14"						
16"						
18"						
20"						
Over 20"						

Finish		
<input type="checkbox"/> /W White <small>(default)</small>	<input type="checkbox"/> /M Mill Finish	<input type="checkbox"/> Custom <small>(please specify)</small>

Schedule type: _____
 Job: _____
 Architect: _____
 Engineer: _____
 Contractor: _____

Single Deflection Spiral Duct Steel Grille Adjustable Air Pattern

Material: Steel fins in extruded aluminum frame.
Adjustable blades.
Finish: Powder paint coating - white.
Mounting: Screw holes mounting.
Spacing: 2/3" Blade Spacing



GDS18

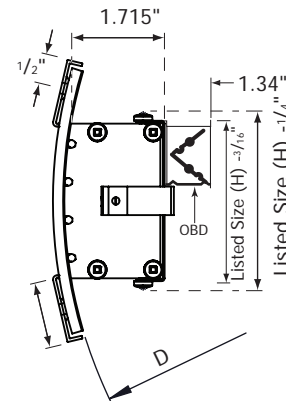
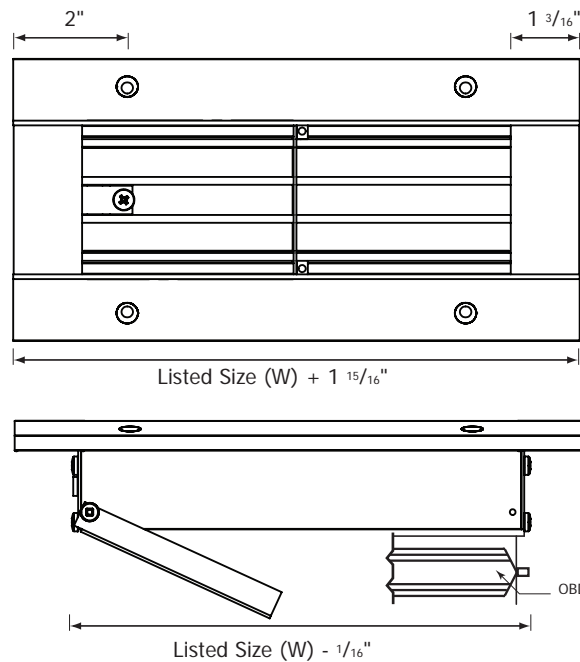
Horizontal Face Blades

- GDS10-H** Steel Fins
- GDS17-H** Steel Opposed Blade Damper
- GDS18-H** Steel Fins with Air Scoop

Vertical Face Blades

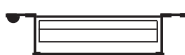
- GDS10-V** Steel Fins
- GDS17-V** Steel Opposed Blade Damper
- GDS18-V** Steel Fins with Air Scoop

Nice feature: Fins follow the curve on the face of the grille.



Options

-GK (1/2"x 1/2" thick)



Flange Gasket
(included over 20" D)



Duct D	H= List Height					
	3"	4"	6"	8"	10"	12"
6"						
8"						
10"						
12"						
14"						
16"						
18"						
20"						
Over 20"						

Finish

/W White (default)
 /M Mill Finish
 Custom (please specify)

Schedule type: _____

Job: _____

Architect: _____

Engineer: _____

Contractor: _____

Double Deflection Spiral Duct Steel Grille Adjustable Air Pattern

- Material:** Steel fins in extruded aluminum frame.
Adjustable blades.
- Finish:** Powder paint coating - white.
- Mounting:** Screw holes mounting.
- Spacing:** 2/3" Blade Spacing


GDS28

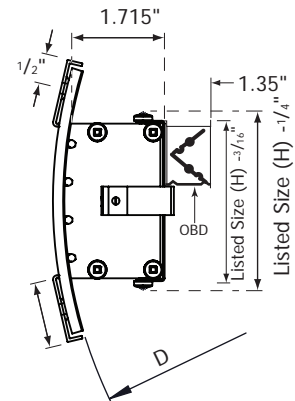
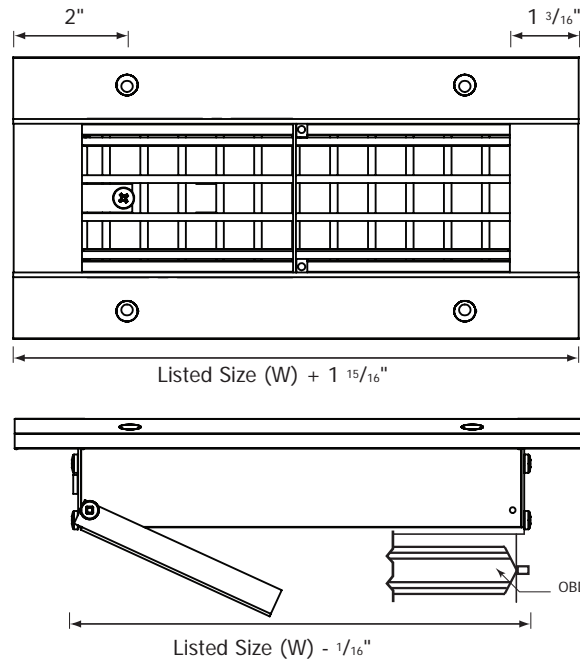
Horizontal Face Blades

- GDS20-H** Steel Fins
- GDS27-H** Steel Opposed Blade Damper
- GDS28-H** Steel Fins with Air Scoop

Vertical Face Blades

- GDS20-V** Steel Fins
- GDS27-V** Steel Opposed Blade Damper
- GDS28-V** Steel Fins with Air Scoop

Nice feature: Fins follow the curve on the face of the grille.



Options

-GK (1/2" x 1/2" thick)

Flange Gasket
(included over 20" D)



Duct D	H= List Height					
	3"	4"	6"	8"	10"	12"
6"						
8"						
10"						
12"						
14"						
16"						
18"						
20"						
Over 20"						

Finish

/W White (default)
 /M Mill Finish
 Custom _____ (please specify)

Schedule type: _____

Job: _____

Architect: _____

Engineer: _____

Contractor: _____

Ceiling Return Grille/Diffuser

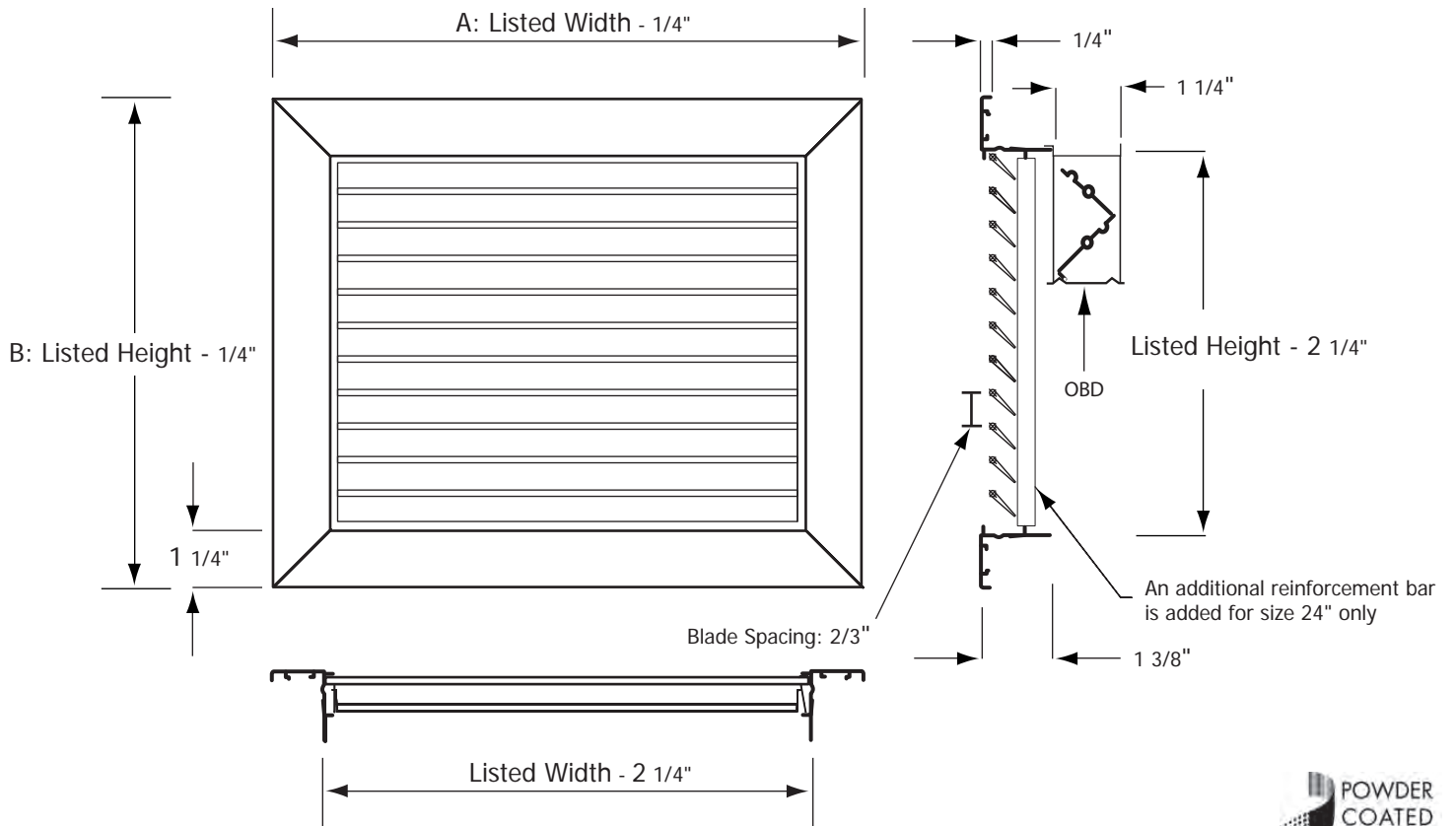
Material: Aluminum construction.
Fixed blades.

Finish: Powder paint white finish.

Mounting: For T-bar lay-in ceiling grids.

GRT without Damper (default)

GRT7 with Damper



Finish		
<input type="checkbox"/> /W White <small>(default)</small>	<input type="checkbox"/> /M Mill Finish	<input type="checkbox"/> Custom <small>(please specify)</small>

✓	Model #	Face Dim. A x B	Neck Size.
	GRT/7 1212	11 3/4" x 11 3/4"	10" x 10"
	GRT/7 2412	23 3/4" x 11 3/4"	22" x 10"
	GRT/7 2424	23 3/4" x 23 3/4"	22" x 22"
	GRT/7 4812	47 3/4" x 11 3/4"	46" x 10"
	GRT/7 4824	47 3/4" x 23 3/4"	46" x 22"

Schedule type: _____

Job: _____

Architect: _____

Engineer: _____

Contractor: _____

Ceiling Return Grille/Diffuser

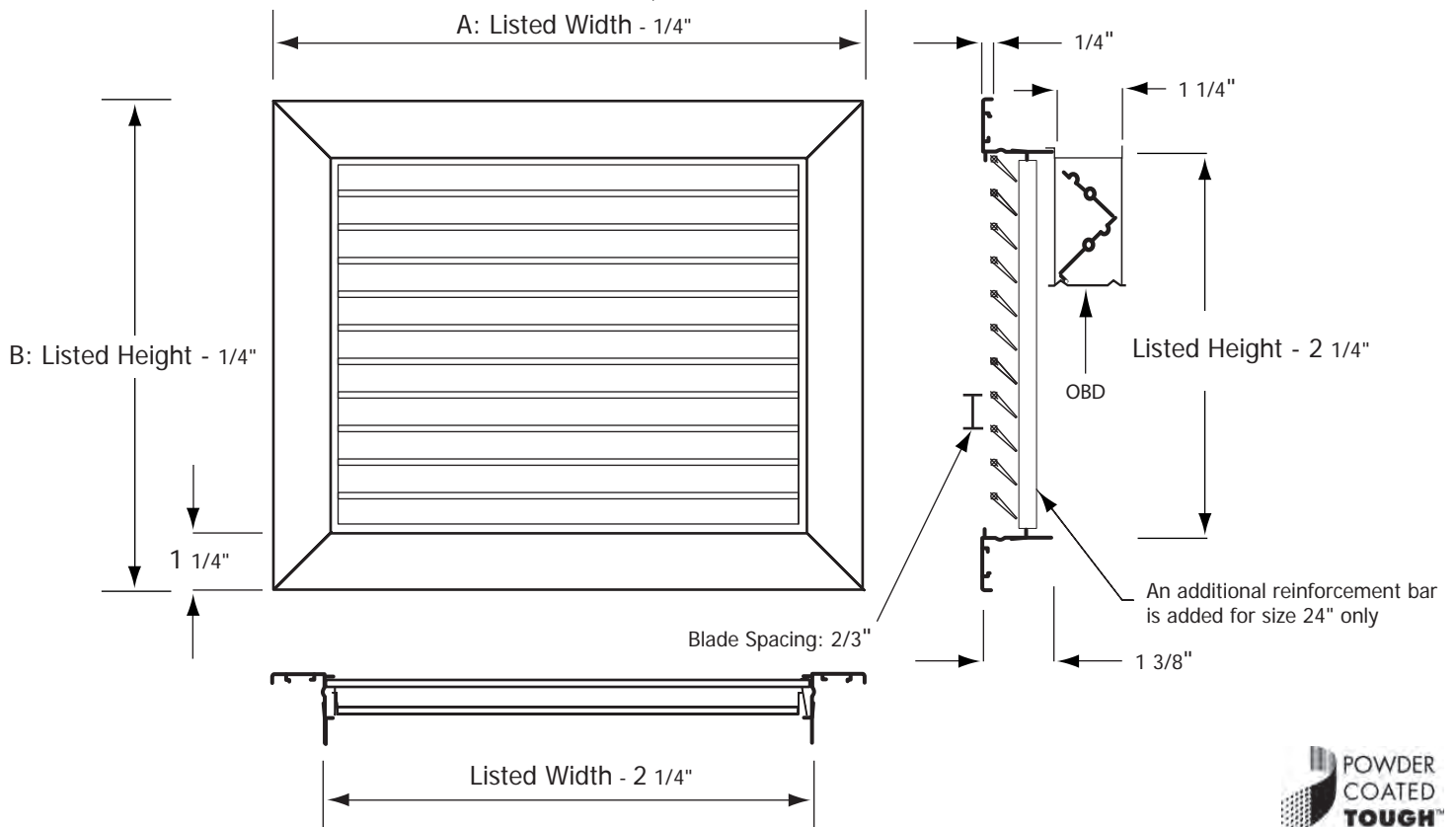
Material: Extruded aluminum frame.
 Fixed blades.
Finish: Powder paint white finish.
Mounting: For T-bar lay-in ceiling grids.

Steel Bars

- GRTS** without Damper (default)
 GRTS7 with Damper

Aluminum Bars

- GRТА** without Damper (default)
 GRТА7 with Damper



✓	Model #	Face Dim. A x B	Neck Size.
	GRTS/7 1212	11 3/4" x 11 3/4"	10" x 10"
	GRTS/7 2412	23 3/4" x 11 3/4"	22" x 10"
	GRTS/7 2424	23 3/4" x 23 3/4"	22" x 22"
	GRTS/7 4812	47 3/4" x 11 3/4"	46" x 10"
	GRTS/7 4824	47 3/4" x 23 3/4"	46" x 22"

Finish		
<input type="checkbox"/> /W White (default)	<input type="checkbox"/> /M Mill Finish	<input type="checkbox"/> Custom (please specify) _____

Schedule type: _____
 Job: _____
 Architect: _____
 Engineer: _____
 Contractor: _____

Single Deflection Supply Grille Adjustable Air Pattern

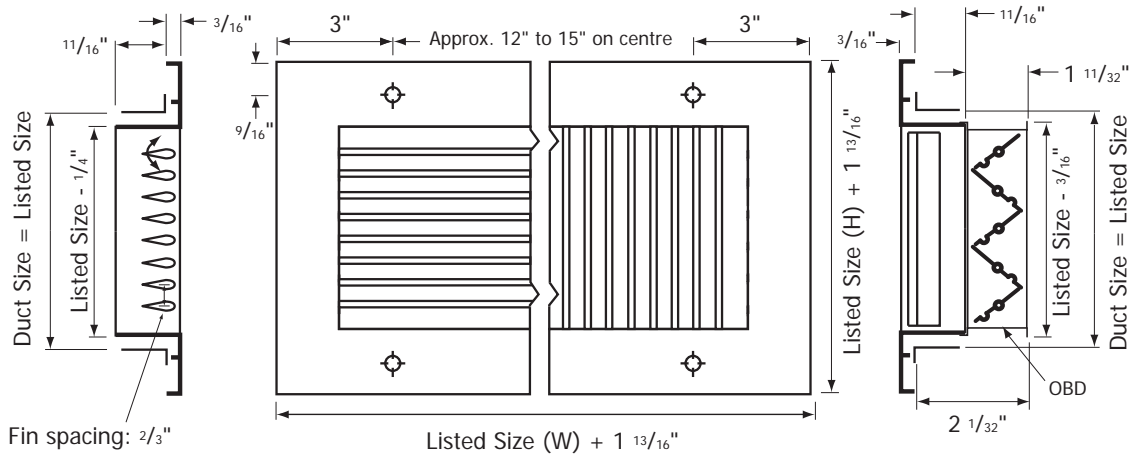
Horizontal Face Bars (Standard) (Mullion required for w > 18")

- GSA10** Steel
- GSA17** Steel with OBD
- GAA10** Aluminum
- GAA17** Aluminum with OBD



Vertical Face Bars

- GSA10-V** Steel
- GSA17-V** Steel with OBD
- GAA10-V** Aluminum
- GAA17-V** Aluminum with OBD



Options			
<input type="checkbox"/> -GK Flange Gasket	<input type="checkbox"/> -GN Neck Gasket	<input type="checkbox"/> -GR Rear Gasket	
<input type="checkbox"/> -SF Supplied w/ sub frame	<input type="checkbox"/> -DS Debris (Bird) Screen	<input type="checkbox"/> -IS Insect Screen	<input type="checkbox"/> -FB Fixed Blades 0 degrees



Finish				
<input type="checkbox"/> /W White (default)	<input type="checkbox"/> /B Brushed Aluminium	<input type="checkbox"/> /M Mill Finish	<input type="checkbox"/> /L Brushed and Lacquered	<input type="checkbox"/> /Custom (Please Specify)

Panel Option for T-bar lay-in Ceiling		
	Steel (WxH)	Aluminum (WxH)
	<input type="checkbox"/> -X1212	<input type="checkbox"/> -Y1212
	<input type="checkbox"/> -X1224	<input type="checkbox"/> -Y1224
	<input type="checkbox"/> -X2412	<input type="checkbox"/> -Y2412
	<input type="checkbox"/> -X2424	<input type="checkbox"/> -Y2424
	<input type="checkbox"/> -X2448	<input type="checkbox"/> -Y2448
	<input type="checkbox"/> -X4824	<input type="checkbox"/> -Y4824
	<input type="checkbox"/> -X2020	<input type="checkbox"/> -Y2020

No fastening options available

Fastening Method			
<input type="checkbox"/> -1 No Fastening	<input type="checkbox"/> -2 Spring clip	<input type="checkbox"/> -3 Screw holes (Standard)	<input type="checkbox"/> -6 Adhesive tape tape

Schedule type: _____

Job: _____

Architect: _____

Engineer: _____

Contractor: _____

Double Deflection Supply Grille

Material: Extruded Aluminum Frame
Air Pattern: Adjustable Air Pattern

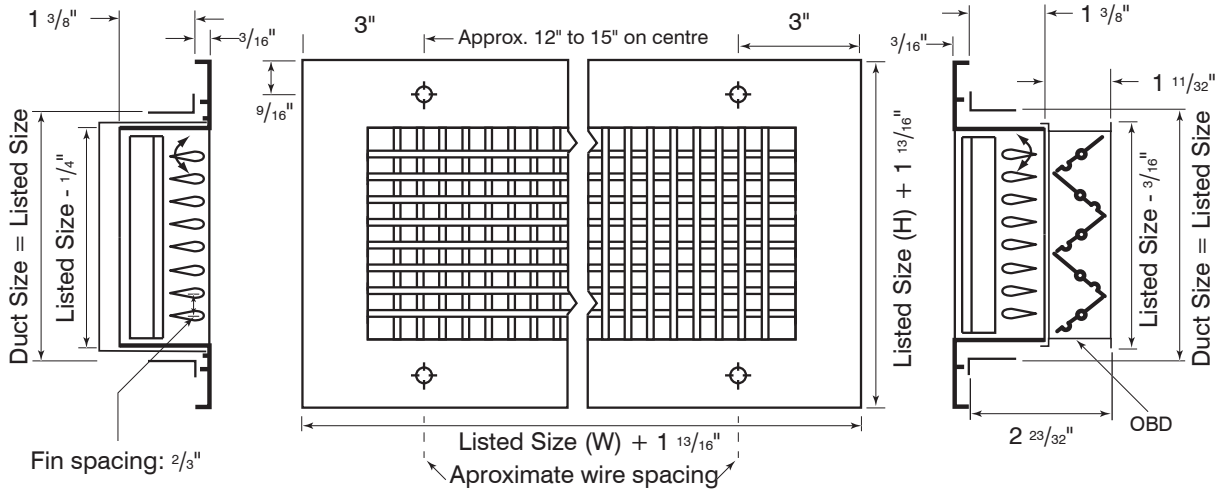
Horizontal Face Bars (Standard) (Mullion required for w>18")

- GSA20** Steel fins
- GSA27** Steel fins with OBD
- GAA20** Aluminum fins
- GAA27** Aluminum fins with OBD



Vertical Face Bars

- GSA20-V** Steel fins
- GSA27-V** Steel fins with OBD
- GAA20-V** Aluminum fins
- GAA27-V** Aluminum fins with OBD



Options			
-GK Flange Gasket	-GN Neck Gasket	-GR Rear Gasket	
-SF Supplied w/ sub frame	-DS Debris (Bird) Screen	-IS Insect Screen	-FB Fixed Blades 0 degrees



Finish				
/W White (default)	/B Brushed Aluminium	/M Mill Finish	/L Brushed and Lacquered	/C Custom (Please Specify)

Panel Option for T-bar lay-in Ceiling		
	Steel (WxH)	Aluminum (WxH)
	<input type="checkbox"/> -X1212	<input type="checkbox"/> -Y1212
	<input type="checkbox"/> -X1224	<input type="checkbox"/> -Y1224
	<input type="checkbox"/> -X2412	<input type="checkbox"/> -Y2412
	<input type="checkbox"/> -X2424	<input type="checkbox"/> -Y2424
	<input type="checkbox"/> -X2448	<input type="checkbox"/> -Y2448
	<input type="checkbox"/> -X4824	<input type="checkbox"/> -Y4824
No fastening options available	<input type="checkbox"/> -X2020	<input type="checkbox"/> -Y2020

Fastening Method			
-1 No Fastening 	-2 Spring clip 	-3 Screw holes (Standard) 	-6 Adhesive tape

Schedule type: _____

Job: _____

Architect: _____

Engineer: _____

Contractor: _____

Fixed 45 degree Deflection Return Grille

Options Ext.

-EXT
Reinforced for Outside

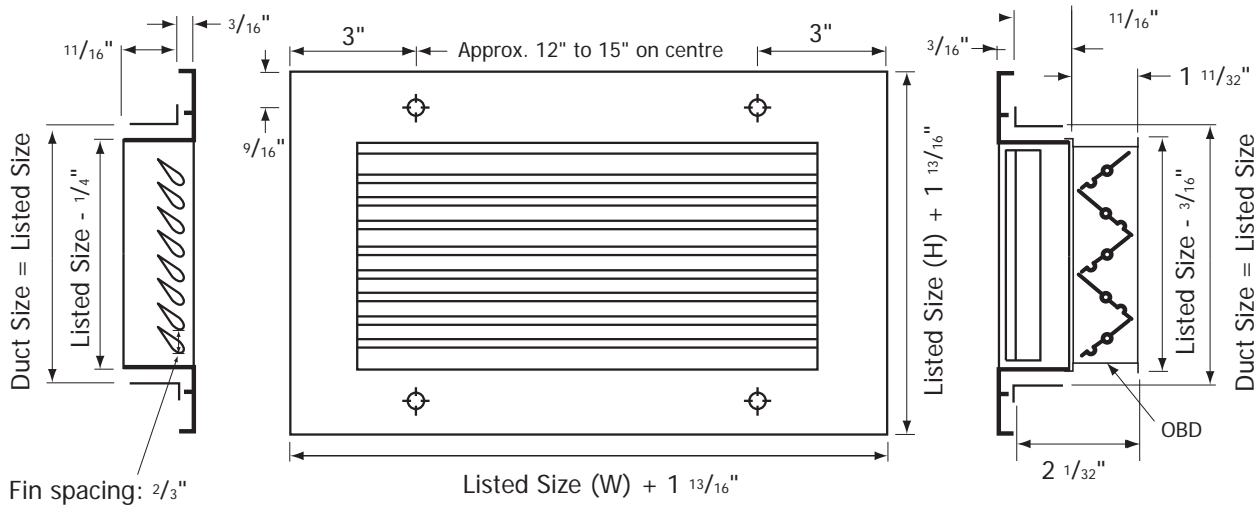
Horizontal Face Bars (Standard) (Mullion required for w>18")

- GSA40** Steel
- GSA47** Steel with OBD
- GAA40** Aluminum
- GAA47** Aluminum with OBD



Vertical Face Bars

- GSA40-V** Steel
- GSA47-V** Steel with OBD
- GAA40-V** Aluminum
- GAA47-V** Aluminum with OBD



Options			
<input type="checkbox"/> -GK Flange Gasket	<input type="checkbox"/> -GN Neck Gasket	<input type="checkbox"/> -GR Rear Gasket	
<input type="checkbox"/> -SF Supplied w/ sub frame	<input type="checkbox"/> -DS Debris (Bird) Screen	<input type="checkbox"/> -IS Insect Screen	<input type="checkbox"/> -FB Fixed Blades 0 degrees



Finish				
<input type="checkbox"/> /W White (default)	<input type="checkbox"/> /B Brushed Aluminium	<input type="checkbox"/> /M Mill Finish	<input type="checkbox"/> /L Brushed and Lacquered	<input type="checkbox"/> /Custom (Please Specify)

Panel Option for T-bar lay-in Ceiling		
	Steel (WxH)	Aluminum (WxH)
	<input type="checkbox"/> -X1212	<input type="checkbox"/> -Y1212
	<input type="checkbox"/> -X1224	<input type="checkbox"/> -Y1224
	<input type="checkbox"/> -X2412	<input type="checkbox"/> -Y2412
	<input type="checkbox"/> -X2424	<input type="checkbox"/> -Y2424
	<input type="checkbox"/> -X2448	<input type="checkbox"/> -Y2448
	<input type="checkbox"/> -X4824	<input type="checkbox"/> -Y4824
	<input type="checkbox"/> -X2020	<input type="checkbox"/> -Y2020

No fastening options available

Fastening Method			
<input type="checkbox"/> -1 No Fastening	<input type="checkbox"/> -2 Spring clip	<input type="checkbox"/> -3 Screw holes (Standard)	<input type="checkbox"/> -6 Adhesive tape

Schedule type: _____

Job: _____

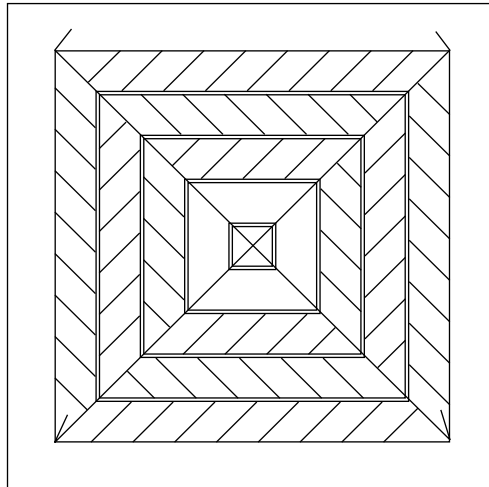
Architect: _____

Engineer: _____

Contractor: _____

High Induction Vanes

Material: Aluminum vanes crimped on the back of the diffuser's face.
 Pushes air in alternate centrifugal directions to create induction.
 Promotes rapid mixing of room air and supply air.



Finish	
<input type="checkbox"/> /W White (Default)	<input type="checkbox"/> /C Custom (Please Specify) _____



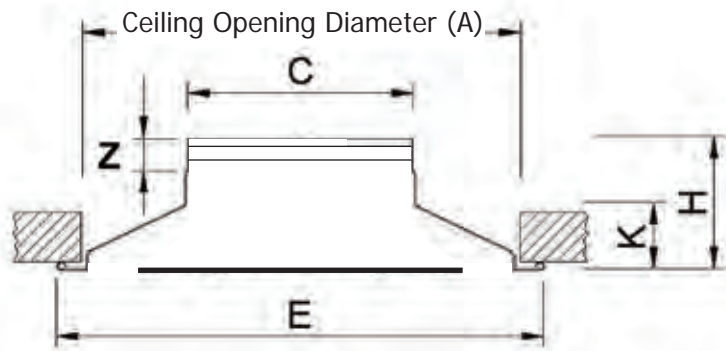
Schedule type: _____
Job: _____
Architect: _____
Engineer: _____
Contractor: _____

High Ceiling Round Diffuser Spun Aluminum

Material: Heavy gauge spun aluminum.
Finish: Powder paint coating - white.
Air Pattern: 360° diffusion, vertically.
Mounting: Surface or open ceiling.



ICG



Model	Duct Size	A (in)	C (in)	E (in)	H (in)	K (in)	Z (in)
ICG 06	6"	11 59/64	5 3/4	13 5/16	4 15/16	1 47/64	1
ICG 08	8"	15 5/32	7 3/4	16 47/64	4 17/32	2 9/32	1
ICG 10	10"	18 17/64	9 3/4	19 3/8	4 31/64	2 1/4	1
ICG 12	12"	22 13/64	11 3/4	23 17/64	6 19/32	3 5/32	1
ICG 14	14"	24 13/16	13 29/32	26 1/16	5 33/64	3 17/64	1
ICG 16	16"	24 13/16	15 43/64	26 1/16	5 5/32	2 59/64	1
ICG 18	18"	31 7/32	17 19/32	32 3/4	6 13/16	4 11/64	1
ICG 20	20"	31 7/32	19 9/16	32 3/4	6 27/64	3 13/16	1

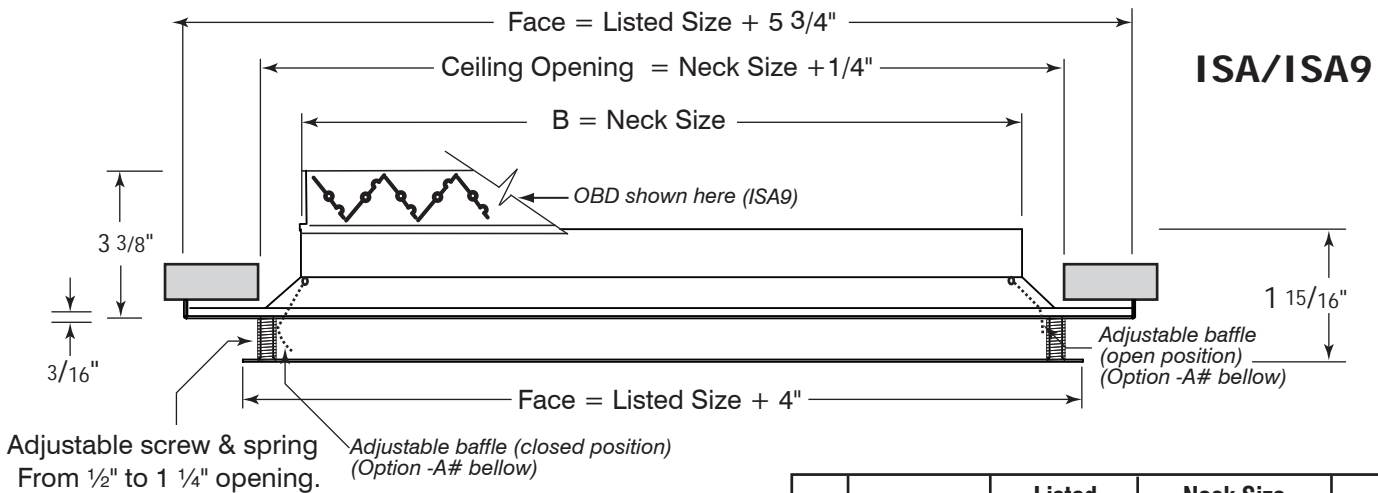
Finish	
<input type="checkbox"/> /W White (Default)	<input type="checkbox"/> /C Custom (Please Specify) _____



Schedule type: _____
Job: _____
Architect: _____
Engineer: _____
Contractor: _____

Ceiling Diffuser - Adjustable Plaque Diffusers Directional Fixed Air Pattern - Square Neck

Material: Heavy gauge aluminum.
Finish: Powder paint coating - white.
Mounting: Surface or Lay-in T-bar ceiling.
Volume Control: Available with pre-installed aluminum OBD (Model# ISA9).



✓	Model #	Listed Size	Neck Size B	Face Size
	ISA 0606	6" x 6"	5 15/16" x 5 15/16"	11 3/4" x 11 3/4"
	ISA 0909	9" x 9"	8 15/16" x 8 15/16"	14 3/4" x 14 3/4"
	ISA 1212	12" x 12"	11 15/16" x 11 15/16"	17 3/4" x 17 3/4"
	ISA 1515	15" x 15"	15 15/16" x 15 15/16"	20 3/4" x 20 3/4"
	ISA 1818	18" x 18"	18 15/16" x 18 15/16"	23 3/4" x 23 3/4"
	ISA9 0606	6" x 6"	6 3/16" x 6 3/16"	11 3/4" x 11 3/4"
	ISA9 0909	9" x 9"	9 3/16" x 9 3/16"	14 3/4" x 14 3/4"
	ISA9 1212	12" x 12"	12 3/16" x 12 3/16"	17 3/4" x 17 3/4"
	ISA9 1515	15" x 15"	15 3/16" x 15 3/16"	20 3/4" x 20 3/4"
	ISA9 1818	18" x 18"	18 3/16" x 18 3/16"	23 3/4" x 23 3/4"

Baffle direction option				
-A1 Baffle	-AC 2 Corner Baffle	-AO 2 Opposed Baffle	-A3 3 Baffle	-A4 4 Baffle

Mounting		
-0 Lay-In (Standard)	-3 Screw Holes	-4 Concealed

Panel Option for T-bar lay-in Ceiling		
	Steel (WxH)	Aluminum (WxH)
	<input type="checkbox"/> -X2412	<input type="checkbox"/> -Y2412
	<input type="checkbox"/> -X2424	<input type="checkbox"/> -Y2424
	<input type="checkbox"/> -X4812	<input type="checkbox"/> -Y4812
	<input type="checkbox"/> -X4824	<input type="checkbox"/> -Y4824
No mounting options available	<input type="checkbox"/> -X2020	<input type="checkbox"/> -Y2020

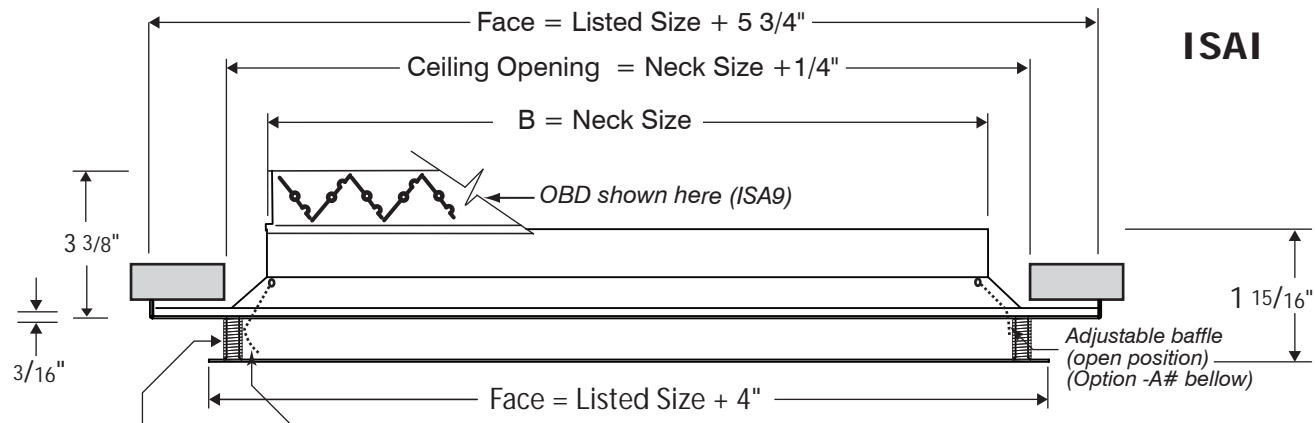
Finish	
<input type="checkbox"/> /W White (Default)	<input type="checkbox"/> /C Custom (Please Specify)



Schedule type: _____
 Job: _____
 Architect: _____
 Engineer: _____
 Contractor: _____

Ceiling Diffuser - Adjustable Plaque Diffusers Directional Fixed Air Pattern - Square Neck

Material: Heavy gauge aluminum.
Finish: Powder paint coating - white.
Mounting: Surface or Lay-in T-bar ceiling.
Volume Control: Available with pre-installed aluminum OBD (Model# ISA9).



Adjustable screw & spring
From 1/2" to 1 1/4" opening.

ISAI

✓	Model #	Listed Size	Neck Size B	Face Size
	ISA 0606	6" x 6"	5 15/16" x 5 15/16"	11 3/4" x 11 3/4"
	ISA 0909	9" x 9"	8 15/16" x 8 15/16"	14 3/4" x 14 3/4"
	ISA 1212	12" x 12"	11 15/16" x 11 15/16"	17 3/4" x 17 3/4"
	ISA 1515	15" x 15"	15" x 15"	20 3/4" x 20 3/4"
	ISA 1818	18" x 18"	18" x 18"	23 3/4" x 23 3/4"
	ISA9 0606	6" x 6"	6 3/16" x 6 3/16"	11 3/4" x 11 3/4"
	ISA9 0909	9" x 9"	9 3/16" x 9 3/16"	14 3/4" x 14 3/4"
	ISA9 1212	12" x 12"	12 3/16" x 12 3/16"	17 3/4" x 17 3/4"
	ISA9 1515	15" x 15"	15 3/16" x 15 3/16"	20 3/4" x 20 3/4"
	ISA9 1818	18" x 18"	18 3/16" x 18 3/16"	23 3/4" x 23 3/4"

Baffle direction option				
-A1 Baffle	-AC 2 Corner Baffle	-AO 2 Opposed Baffle	-A3 3 Baffle	-A4 4 Baffle

Mounting		
-0 Lay-In (Standard)	-3 Screw Holes	-4 Concealed

Panel Option for T-bar lay-in Ceiling		
	Steel (WxH)	Aluminum (WxH)
	<input type="checkbox"/> -X2412	<input type="checkbox"/> -Y2412
	<input type="checkbox"/> -X2424	<input type="checkbox"/> -Y2424
	<input type="checkbox"/> -X4812	<input type="checkbox"/> -Y4812
	<input type="checkbox"/> -X4824	<input type="checkbox"/> -Y4824
No mounting options available	<input type="checkbox"/> -X2020	<input type="checkbox"/> -Y2020

Finish	
<input type="checkbox"/> /W White (Default)	<input type="checkbox"/> /C Custom (Please Specify)



Schedule type: _____

Job: _____

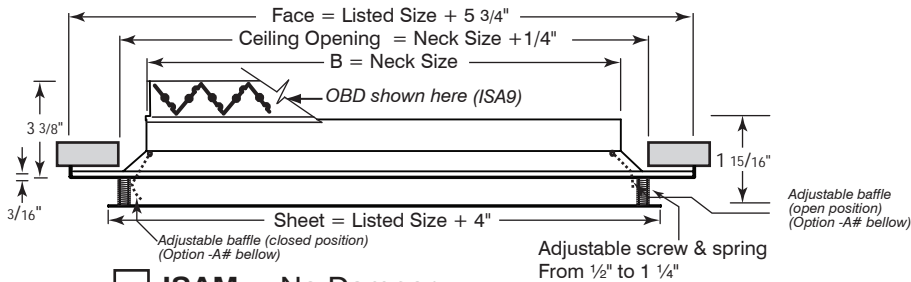
Architect: _____

Engineer: _____

Contractor: _____

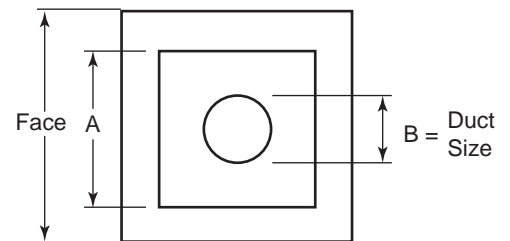
Ceiling Diffuser - Adjustable Plaque Diffuseurs Directional Fixed Air Pattern - Round Neck

Material: Heavy gauge aluminum.
Finish: Powder paint coating - white.
Mounting: Surface or Lay-in T-bar ceiling.
Volume Control: Available with pre-installed opposed blade damper (Model# ISAM4) or radial sliding blade damper (Model# ISAM5).



- ISAM** No Damper
- ISAM4** Pre-Installed N4 Opposed Blade Damper
- ISAM5** Pre-Installed N5 Radial Sliding Blade Damper

ISAM



Baffle direction option				
-A1 Baffle	-AC 2 Corner Baffle	-AO 2 Opposed Baffle	-A3 3 Baffle	-A4 4 Baffle

Mounting		
<input type="checkbox"/> -0 Lay-In (Standard)	<input type="checkbox"/> -3 Screw Holes	<input type="checkbox"/> -4 Concealed

Finish	
<input type="checkbox"/> /W White (Default)	<input type="checkbox"/> /C Custom (Please Specify)



Panel Option for T-bar lay-in Ceiling		
	Steel (WxH)	Aluminum (WxH)
	<input type="checkbox"/> -X2412	<input type="checkbox"/> -Y2412
	<input type="checkbox"/> -X2424	<input type="checkbox"/> -Y2424
	<input type="checkbox"/> -X4812	<input type="checkbox"/> -Y4812
	<input type="checkbox"/> -X4824	<input type="checkbox"/> -Y4824
	<input type="checkbox"/> -X2020	<input type="checkbox"/> -Y2020

No mounting options available

✓	Model #	A	B	Neck Size	Face Size
	0606 06	6 x 6	6	5 7/8	11 3/4 x 11 3/4
	0909 06	9 x 9	6	5 7/8	14 3/4 x 14 3/4
	0909 08	9 x 9	8	7 7/8	14 3/4 x 14 3/4
	1212 06	12 x 12	6	5 7/8	17 3/4 x 17 3/4
	1212 08	12 x 12	8	7 7/8	17 3/4 x 17 3/4
	1212 10	12 x 12	10	9 7/8	17 3/4 x 17 3/4
	1212 12	12 x 12	12	11 7/8	17 3/4 x 17 3/4
	1515 06	15 x 15	6	5 7/8	20 3/4 x 20 3/4
	1515 08	15 x 15	8	7 7/8	20 3/4 x 20 3/4
	1515 10	15 x 15	10	9 7/8	20 3/4 x 20 3/4
	1515 12	15 x 15	12	11 7/8	20 3/4 x 20 3/4
	1515 14 ¹	15 x 15	14	13 7/8	20 3/4 x 20 3/4
	1818 06	18 x 18	6	5 7/8	23 3/4 x 23 3/4
	1818 08	18 x 18	8	7 7/8	23 3/4 x 23 3/4
	1818 10	18 x 18	10	9 7/8	23 3/4 x 23 3/4
	1818 12	18 x 18	12	11 7/8	23 3/4 x 23 3/4
	1818 14 ¹	18 x 18	14	13 7/8	23 3/4 x 23 3/4
	1818 16 ²	18 x 18	16	15 7/8	23 3/4 x 23 3/4

¹ Size not available for DLAM5 ² Size not available for DLAM4 and DLAM5

Schedule type: _____

Job: _____

Architect: _____

Engineer: _____

Contractor: _____

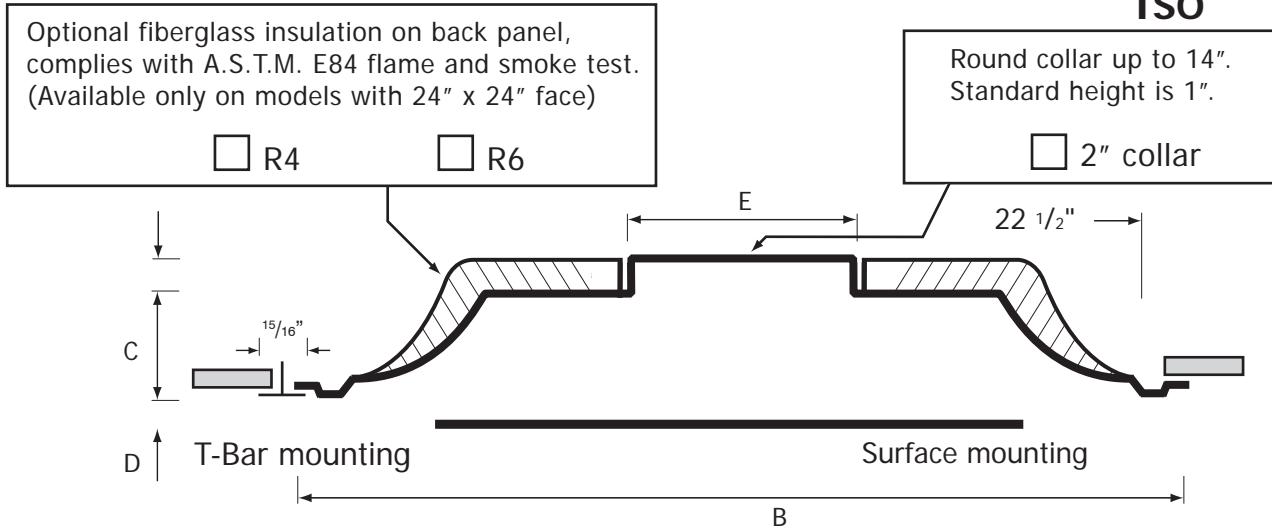
SUBMITTAL SHEET

Square Plaque Diffuser - Architectural Line

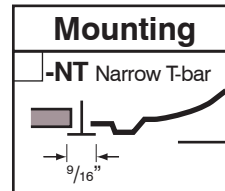


ISO

- Material:** Stamped heavy gauge steel.
- Finish:** Powder paint coating - white.
- Mounting:** Surface or Lay-in T-bar ceiling.
- Air Pattern:** Fixed horizontal 360° diffusion.
- Core Removal:** Unlock hanger brackets by swiveling lever down. Holding core panel at opposite sides, push upwards, then turn clockwise and drop core free from back plenum.



✓	Model #	Duct Size	E	Face Dim B x B	C	D
	ISO 1206	6	5 7/8"	11 3/4" x 11 3/4"	1 3/4"	7/16"
	IOS 1208	8	7 7/8"	11 3/4" x 11 3/4"	1 3/4"	7/16"
	IOS 2406	6	5 7/8"	23 3/4" x 23 3/4"	2 7/8"	7/8"
	IOS 2408	8	7 7/8"	23 3/4" x 23 3/4"	2 7/8"	7/8"
	IOS 2410	10	9 7/8"	23 3/4" x 23 3/4"	2 7/8"	7/8"
	IOS 2412	12	11 7/8"	23 3/4" x 23 3/4"	2 7/8"	7/8"
	IOS 2414	14	13 7/8"	23 3/4" x 23 3/4"	2 7/8"	7/8"



Finish

/W White (Default) /C Custom (Please Specify)



Panel Option for T-bar lay-in Ceiling

W

H

No fastening options available

Steel (WxH)	Aluminum (WxH)
<input type="checkbox"/> -X2412	<input type="checkbox"/> -Y2412
<input type="checkbox"/> -X2424	<input type="checkbox"/> -Y2424
<input type="checkbox"/> -X2448	<input type="checkbox"/> -Y2448
<input type="checkbox"/> -X4824	<input type="checkbox"/> -Y4824
<input type="checkbox"/> -X2020	<input type="checkbox"/> -Y2020

Schedule type: _____

Job: _____

Architect: _____

Engineer: _____

Contractor: _____

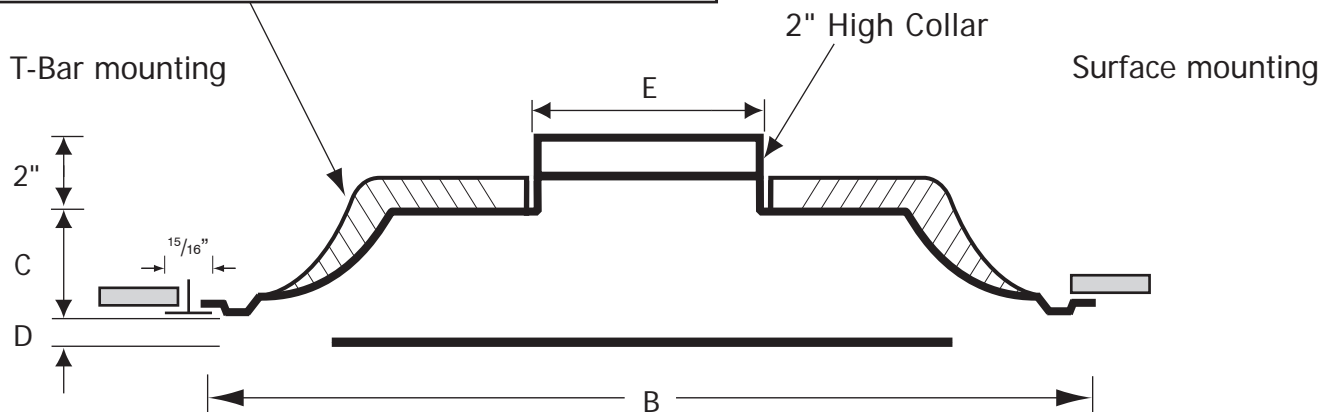
Square Plaque Diffuser - Architectural Line 2" High Collar, Individual Packaging

- Material:** Stamped heavy gauge steel.
Finish: Powder paint coating - white.
Mounting: Surface or Lay-in T-bar ceiling.
Air Pattern: Fixed horizontal 360° diffusion.
Core Removal: Unlock hanger brackets by swiveling lever down. Holding core panel at opposite sides, push upwards, then turn clockwise and drop core free from back plenum.


ISOD

Optional R6 fiberglass insulation on back panel complies with A.S.T.M. E84 flame and smoke test.

- R4 R6



Mounting	
<input type="checkbox"/> -NT	Narrow T-bar

✓	Model #	Duct Size	E	Face Dim B x B	C	D
	ISOD 2406	6	5 7/8"	23 3/4" x 23 3/4"	2 7/8"	7/8"
	ISOD 2408	8	7 7/8"	23 3/4" x 23 3/4"	2 7/8"	7/8"
	ISOD 2410	10	9 7/8"	23 3/4" x 23 3/4"	2 7/8"	7/8"
	ISOD 2412	12	11 7/8"	23 3/4" x 23 3/4"	2 7/8"	7/8"

Finish	
<input type="checkbox"/> /W White (Default)	<input type="checkbox"/> /C Custom (Please Specify)



Schedule type: _____
 Job: _____
 Architect: _____
 Engineer: _____
 Contractor: _____

Square Plaque Diffuser - Architectural Line Insulated, One Size Fits All

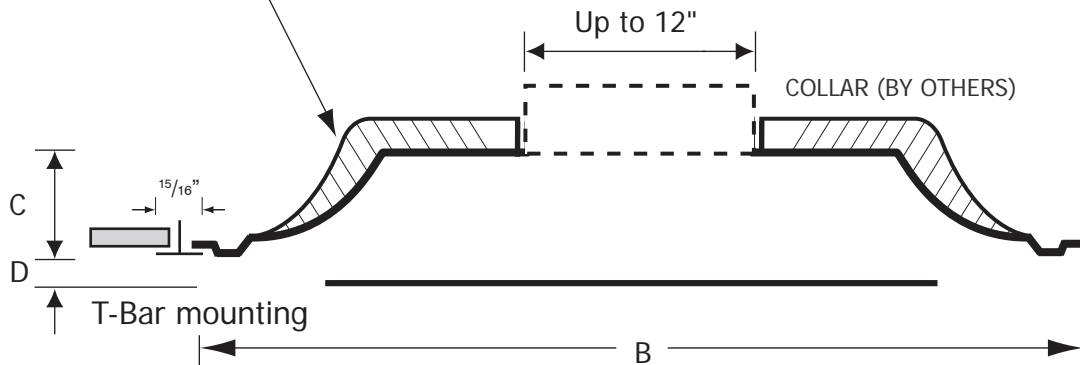
- Material:** Stamped heavy gauge steel.
- Finish:** Powder paint coating - white.
- Mounting:** Lay-in T-bar ceiling.
- Air Pattern:** Fixed horizontal 360° diffusion.
- Core Removal:** Unlock hanger brackets by swiveling lever down. Holding core panel at opposite sides, push upwards, then turn clockwise and drop core free from back plenum.



ISOI

R6 fiberglass back complies with A.S.T.M. E84 flame and smoke test.

Scored for collar sizes up to 12" D. Contractor to install job-specific collar in field. For size 14", please refer to model ISO-R6 2414.



Model #	Face Dim B x B	C	D
ISOI	23 3/4" x 23 3/4"	2 7/8"	7/8"

Finish	
<input type="checkbox"/> /W White (Default)	<input type="checkbox"/> /C Custom (Please Specify)



Schedule type: _____

Job: _____

Architect: _____

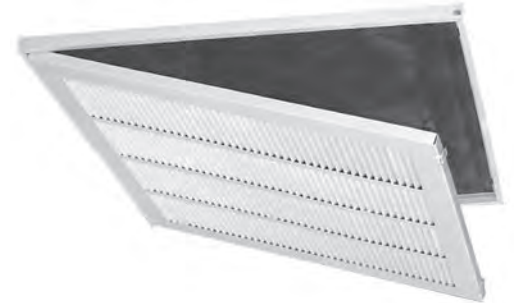
Engineer: _____

Contractor: _____

Lanced Face Filter Return with Molded Fiberglass Back Panel Hinged face

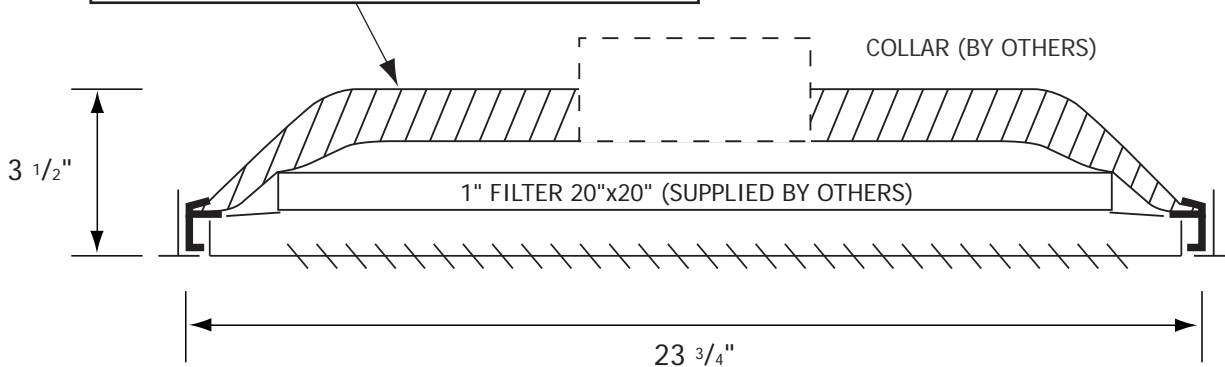
Material: Molded fiberglass back with aluminum foil vapor barrier scored for 6" to 14" D. in an extruded aluminum fixed frame. Steel lanced face with 1/2" spaced fins set at 40° swings in and out of fixed frame, for access to 20"x20" filter, by others.

Finish: Powder paint coating - white.
Mounting: T-bar Lay-in ceiling.



LRIF

Fiberglass back complies with A.S.T.M. E84 flame and smoke test. Scored for collar sizes up to 14" D.
 R4 R6



Finish	
<input type="checkbox"/> /W White (Default)	<input type="checkbox"/> /C Custom (Please Specify) _____



Schedule type: _____

Job: _____

Architect: _____

Engineer: _____

Contractor: _____

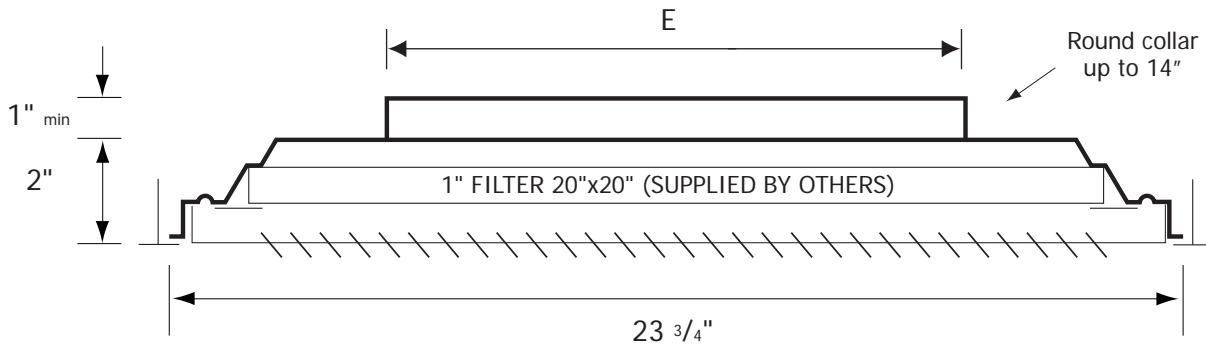
Lanced Face Filter Return with Steel Back Panel, Hinged Face

Material: Stamped heavy gauge steel backpanel with reinforcing corners. Steel lanced face with 1/2" spaced fins at 40° swings in and out of fixed frame, for access to 20"x20" filter, by others.



Finish: Powder paint coating - white.
Mounting: T-bar Lay-in ceiling.

LRMF



✓	Model #	Duct Size	E	Face Dim
	LRMF 2406	6	5 7/8"	23 3/4" x 23 3/4"
	LRMF 2408	8	7 7/8"	23 3/4" x 23 3/4"
	LRMF 2410	10	9 7/8"	23 3/4" x 23 3/4"
	LRMF 2412	12	11 7/8"	23 3/4" x 23 3/4"
	LRMF 2414	14	13 7/8"	23 3/4" x 23 3/4"

Finish	
<input type="checkbox"/> /W White (Default)	<input type="checkbox"/> /C Custom (Please Specify) _____



Schedule type: _____

Job: _____

Architect: _____

Engineer: _____

Contractor: _____

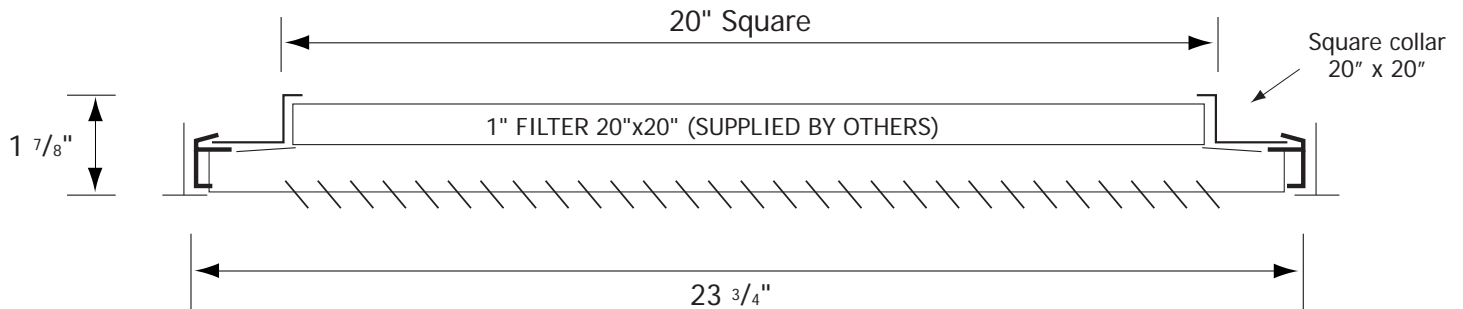
Lanced Face Filter Return with 20" x 20" filter frame Hinged face

Material: Steel filter frame will accept standard 1" filter. Steel lanced face with 1/2" spaced fins at 40° swings in and out of fixed frame, for access to 20"x20" filter, by others.

Finish: Powder paint coating - white.
Mounting: T-bar Lay-in ceiling.


LRTF

SUBMITTAL SHEET



Finish	
<input type="checkbox"/> /W White (default)	<input type="checkbox"/> Custom _____ (please specify)

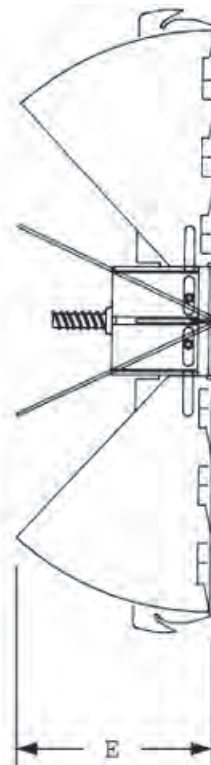
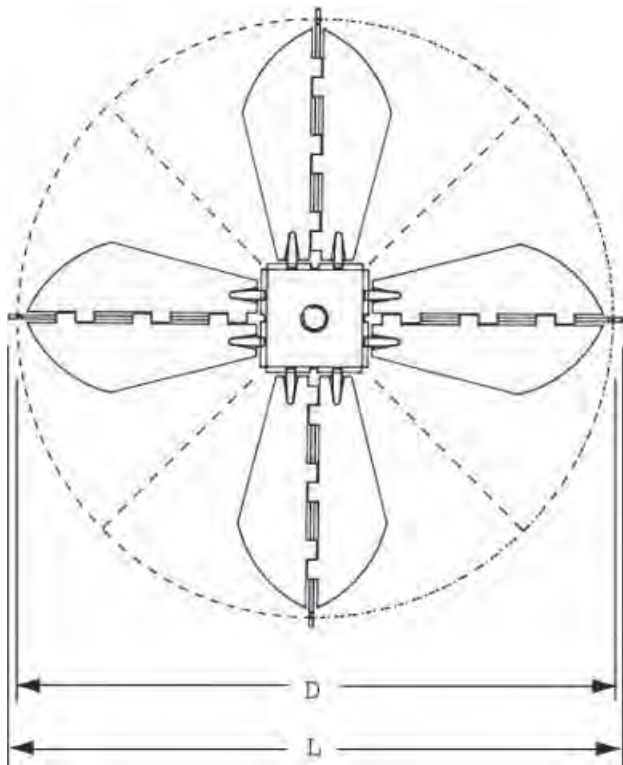
Schedule type: _____
Job: _____
Architect: _____
Engineer: _____
Contractor: _____

Round Opposed Blade Damper

Material: All galvanized steel.
Mounting: Round collar of diffuser.

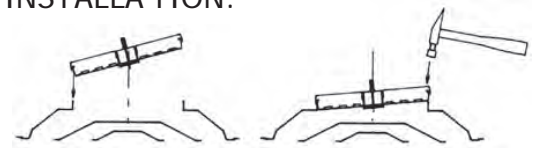


N4
 (N4 08 shown here)



VERTICAL OPERATOR ACCEPTS STANDARD SCREWDRIVER FOR SLOTTED OR HEX HEAD THRU DIFFUSER FACE

INSTALLATION:



✓	Model #	Nom. Size	Overall Dimensions		
			Blade (D)	Brace (L)	Depth (E)
	N4 06	6"	5 3/4"	6"	2 3/8"
	N4 08	8"	7 3/4"	8"	3 1/8"
	N4 10	10"	9 3/4"	10"	3 3/4"
	N4 12	12"	11 3/4"	12"	4 1/2"
	N4 14	14"	13 3/4"	14"	5 1/4"

Finish	
<input type="checkbox"/> /M Mill Finish (Default)	<input type="checkbox"/> /BK Black

Schedule type: _____

Job: _____

Architect: _____

Engineer: _____

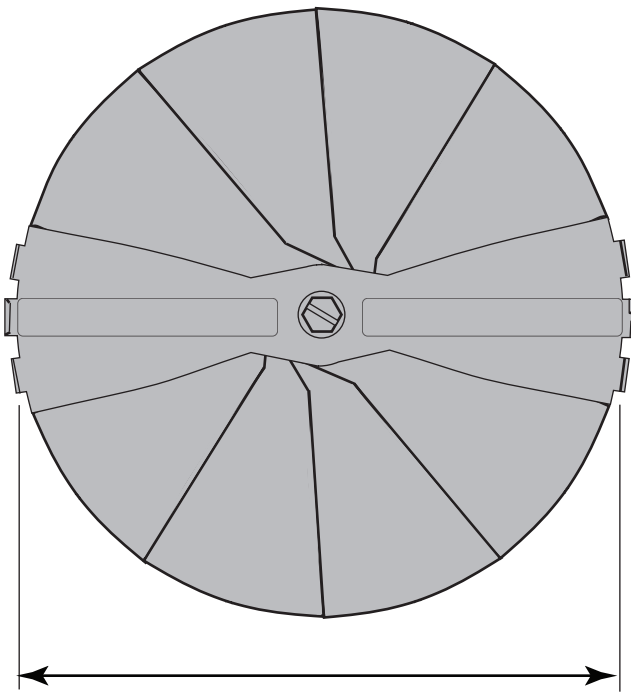
Contractor: _____

Round Sliding Blade Damper

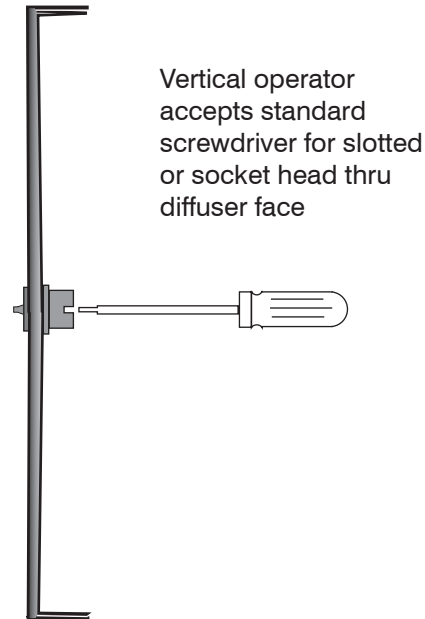
Material: All galvanized steel.
Mounting: Round collar of diffuser.



N5



Actual Size = Nominal Size - 1/2"



✓	Model #	Nom. Size
	N5 06	6"
	N5 08	8"
	N5 10	10"
	N5 12	12"

Finish	
<input type="checkbox"/> /W White (Default)	<input type="checkbox"/> /C Custom (Please Specify)



Schedule type: _____

Job: _____

Architect: _____

Engineer: _____

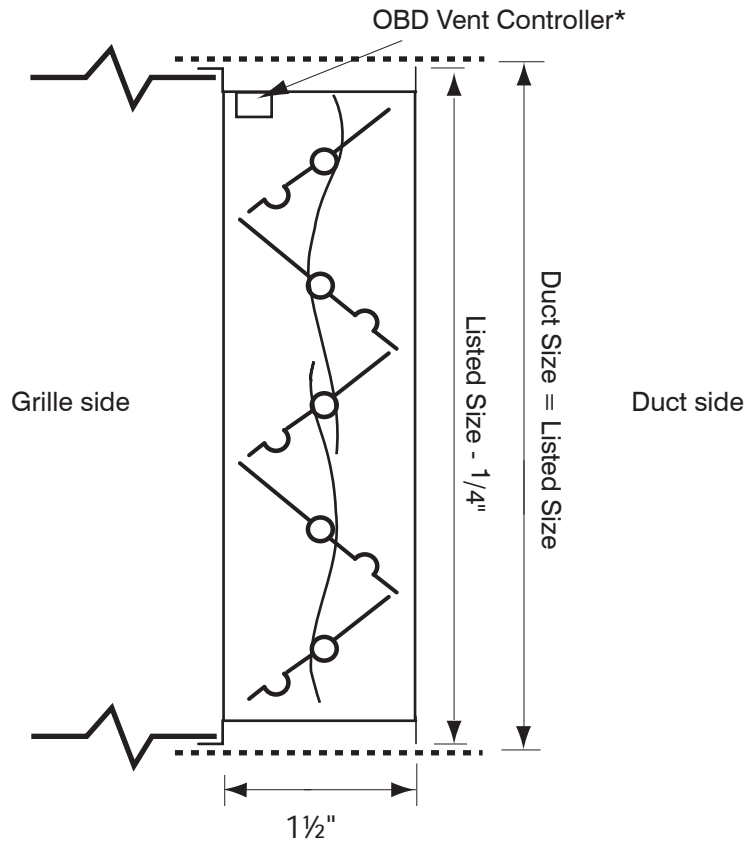
Contractor: _____

Square/Rectangular Opposed Blade Damper

Material: All galvanized steel
Mounting: Square/Rectangular fit to grille



N7



*OBD vent controller accepts standard screwdriver for slotted or socket head thru grille face

Sections are maximum 18 » x 18 ». Larger sizes are in multiple sections.

Schedule type: _____
Job: _____
Architect: _____
Engineer: _____
Contractor: _____

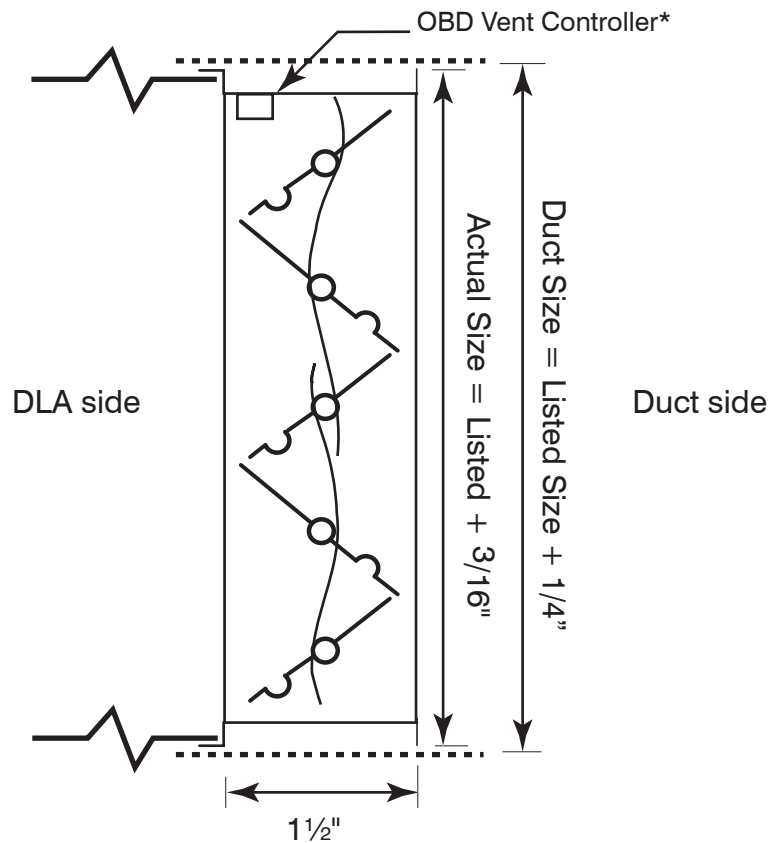
Square Opposed Blade Damper for DLA Series

Material: Aluminum



N9

SUBMITTAL SHEET

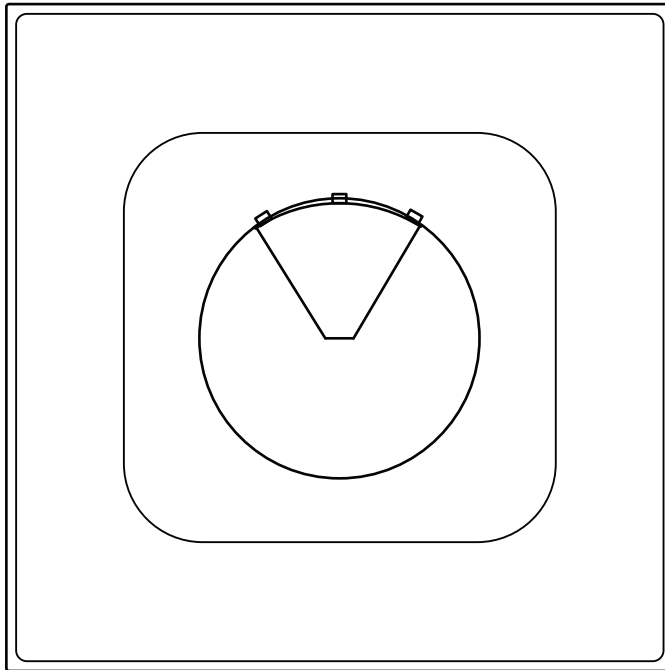


*obd vent controller accepts standard screwdriver for slotted head

Schedule type: _____
Job: _____
Architect: _____
Engineer: _____
Contractor: _____

Baffle For Cone Diffuser With Round Neck

Material: Galvanised steel
Finish: Powder painting - Black
Mounting: Clips



(Top View)



✓	Model #	Duct Size	Neck Size
	NBD 06	6"	5 7/8"
	NBD 08	8"	7 7/8"
	NBD 10	10"	9 7/8"
	NBD 12	12"	11 7/8"
	NBD 14	14"	13 7/8"



Schedule type: _____
Job: _____
Architect: _____
Engineer: _____
Contractor: _____

SUBMITTAL SHEET

N° NBI

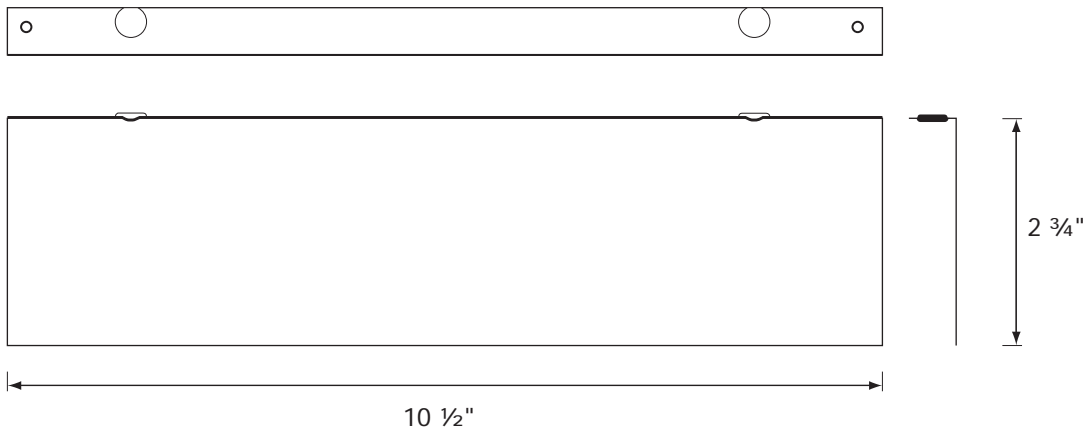
Baffle for ISO plaque diffusers

- Material:** Galvanized Steel
- Finish:** Powder paint coating - white
- Mounting:** Magnets



NBI

SUBMITTAL SHEET



Finish	
<input type="checkbox"/> /W White (default)	<input type="checkbox"/> Custom _____ (please specify)



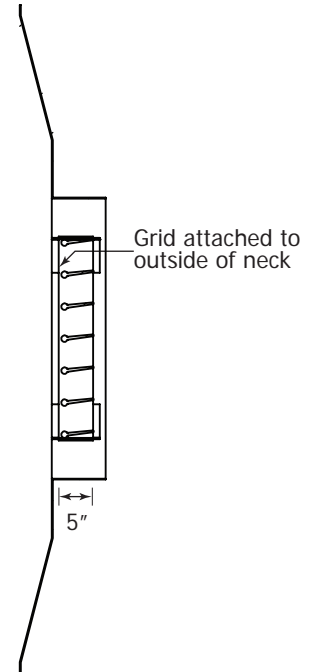
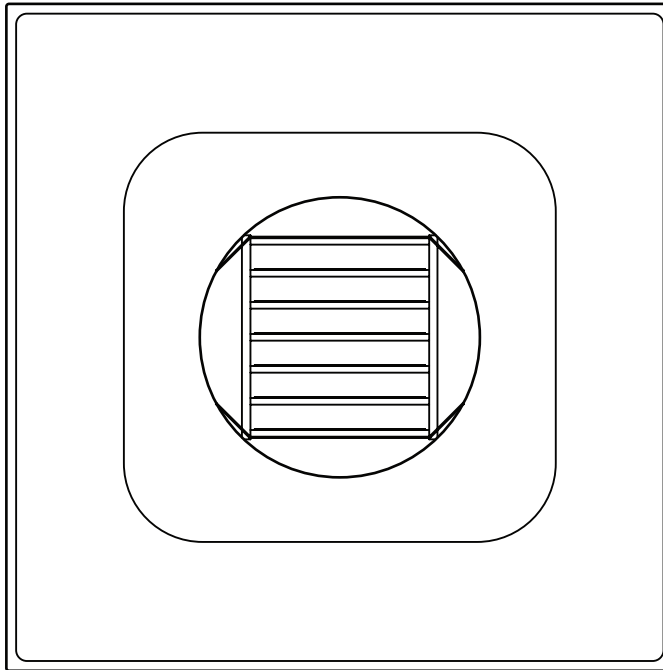
Schedule Type:	_____
Project:	_____
Architect:	_____
Engineer:	_____
Contractor:	_____

Round Equalizing Grid

Material: Extruded aluminum adjustable louver blades used to equalize air flow into round diffuser neck for minimum noise and turbulence.



NEG



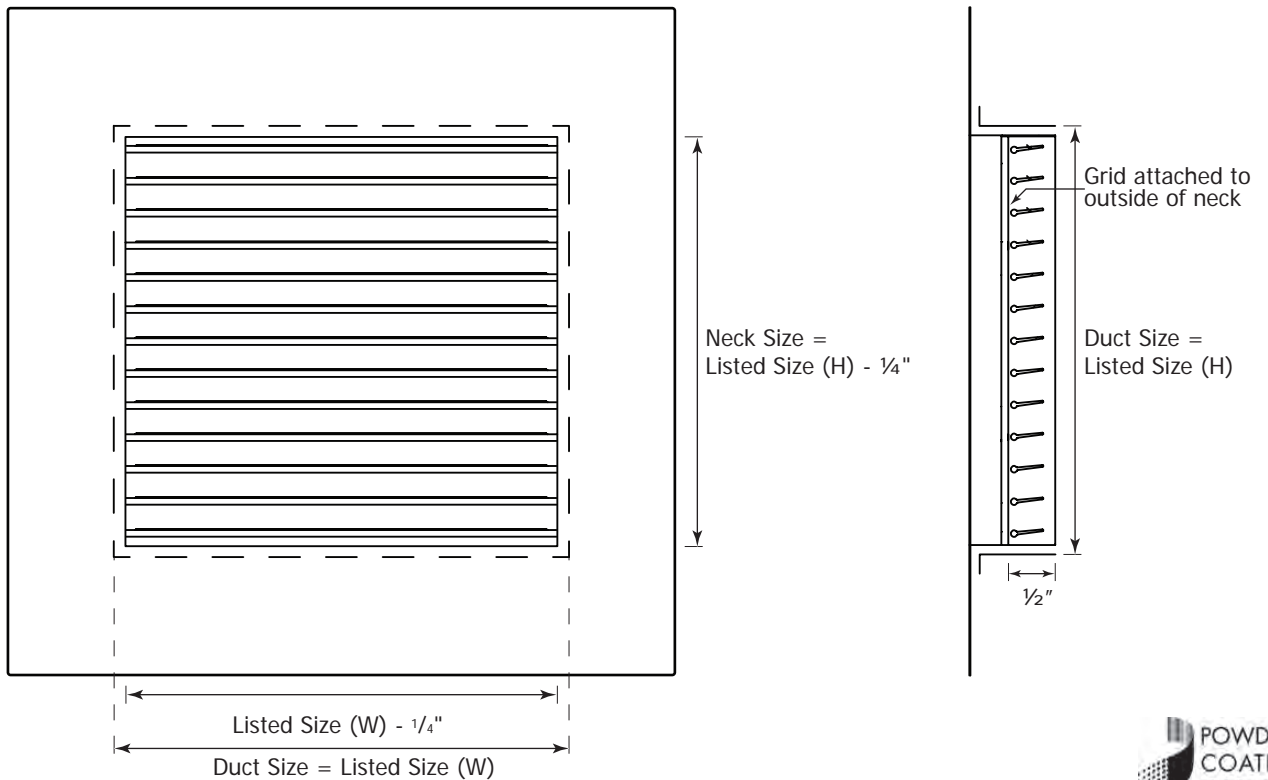
✓	Model #	Duct Size	Neck Size
	NEG 06	6"	5 7/8"
	NEG 08	8"	7 7/8"
	NEG 10	10"	9 7/8"
	NEG 12	12"	11 7/8"
	NEG 14	14"	13 7/8"

Finish			
<input type="checkbox"/> /W White (default)	<input type="checkbox"/> /BK Black	<input type="checkbox"/> /M Mill Finish	<input type="checkbox"/> Custom (please specify) _____

Schedule type: _____
Job: _____
Architect: _____
Engineer: _____
Contractor: _____

Square Equalizing Grid

Material: Extruded aluminum adjustable louver blades used to equalize air flow into square diffuser neck for minimum noise and turbulence.



Maximum one piece dimension : 18" x 18"



✓	Model #
	NES 0606
	NES 0808
	NES 1010
	NES 1212
	NES 1414

Finish			
<input type="checkbox"/> /W White (default)	<input type="checkbox"/> /BK Black	<input type="checkbox"/> /M Mill Finish	<input type="checkbox"/> Custom (please specify) _____

Schedule type: _____
Job: _____
Architect: _____
Engineer: _____
Contractor: _____

R6 Molded Fiberglass Backpan

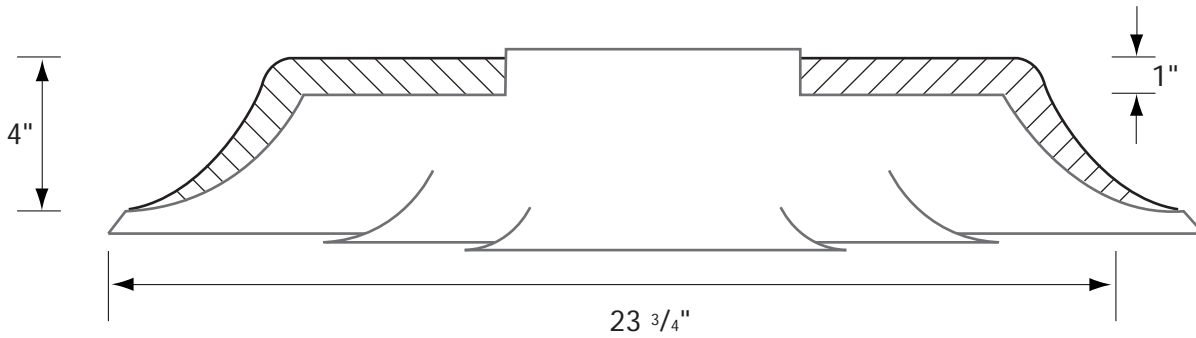
Material: Molded fiberglass with a foil layer on the exterior.



NR6MFG

R6 fiberglass back complies with A.S.T.M. E84 flame and smoke test.

Scored for collar sizes up to 12" D. Contractor to install job-specific collar in field. For size 14", please refer to model DF3-R6 2414. (Available only on models with 24" x 24" face diffusers).



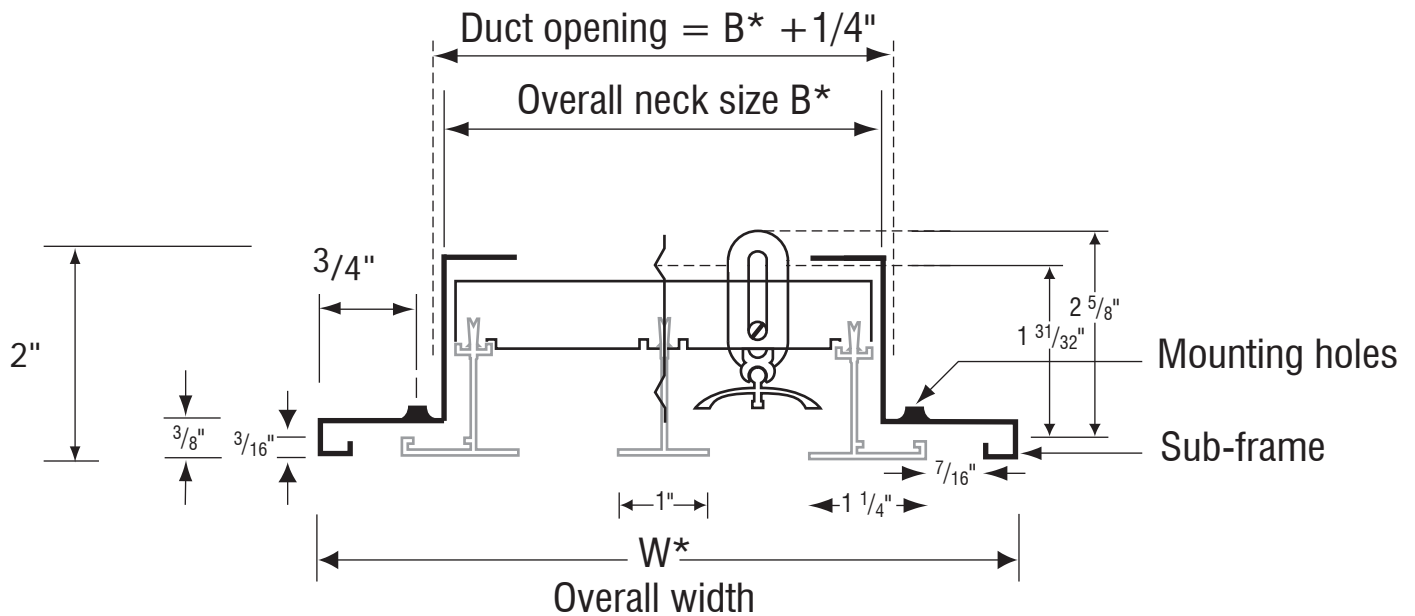
Schedule type: _____
Job: _____
Architect: _____
Engineer: _____
Contractor: _____

Sub-Frame for Linear 1" Slot Diffuser

Material: Extruded aluminum construction
Mounting: Countersunk mounting holes on sub-frame.



NSA1



✓	NO. OF SLOTS	B*	W*
	01	2 5/8"	5"
	02	4 5/8"	7"
	03	6 5/8"	9"
	04	8 5/8"	11"
	05	10 5/8"	13"
	06	12 5/8"	15"
	07	14 5/8"	17"
	08	16 5/8"	19"

Finish	
<input type="checkbox"/> /W White (Default)	<input type="checkbox"/> /C Custom (Please Specify) _____



Mounting	
Surface mounting -E	
<p>Overall Length = List Length + 2 3/8"</p> <p>Duct Opening = List Length + 1/4"</p> <p>Neck Size = List Length</p>	

Schedule type: _____

Job: _____

Architect: _____

Engineer: _____

Contractor: _____

Frame for Narrow T-Bar

Material: Aluminium construction.

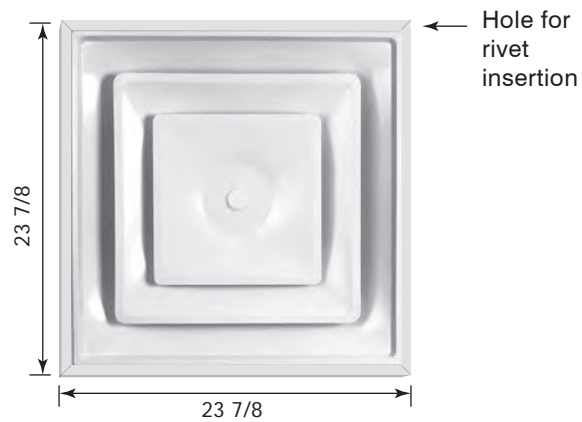


NT
(DF3-NT shown here)

Bending Operation



Riveting Operation



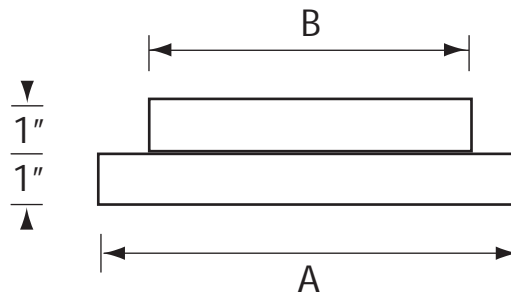
Schedule type: _____
Job: _____
Architect: _____
Engineer: _____
Contractor: _____

Round to Round Transistion

Material: heavy gauge galvanized steel.

Standard is Imperial - Imperial

-MI : Metric - Imperial



✓	Model #	A interior dim Diffuser Collar Insert	B exterior dim Duct Connection
	NTRR 0604	6" D	3 3/4" D
	NTRR 0605	6" D	4 3/4" D
	NTRR 0807	8" D	6 3/4" D
	NTRR 1009	10" D	8 3/4" D
	NTRR 1415	14" D	14 3/4" D
	NTRR-MI 160 6	165 mm D	5 3/4" D
	NTRR-MI 315 12	320 mm D	11 3/4" D

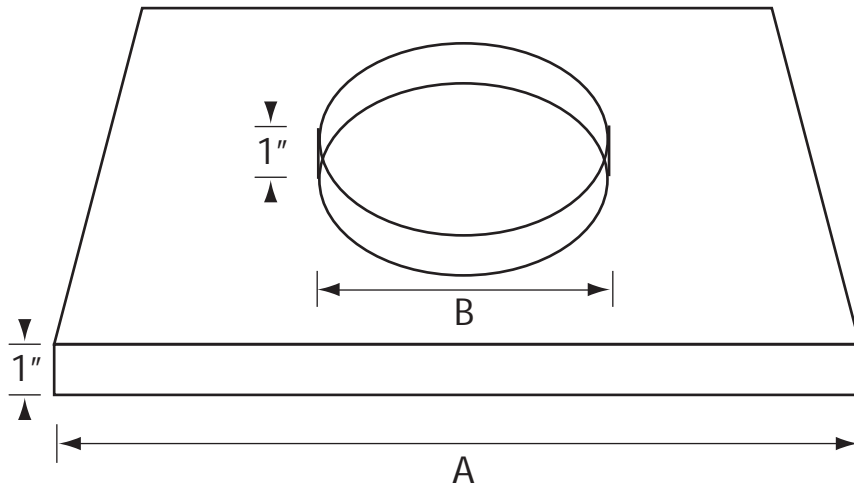


Finish		
<input type="checkbox"/> /M Mill Finish	<input type="checkbox"/> /W White (default)	<input type="checkbox"/> Custom (please specify) _____

Schedule type: _____
Job: _____
Architect: _____
Engineer: _____
Contractor: _____

Square to Round Transition

Material: 22 gauge steel.



✓	NTSR
---	------

✓	Listed A	Actual Interior Dimension
	24	24" x 24"
	22	22" x 22"
	12	12" x 12"
	10	10" x 10"

✓	Listed B	Actual Exterior Dimension
	06	5 7/8"
	08	7 7/8"
	10	9 7/8"
	12	11 7/8"
	14	13 7/8"

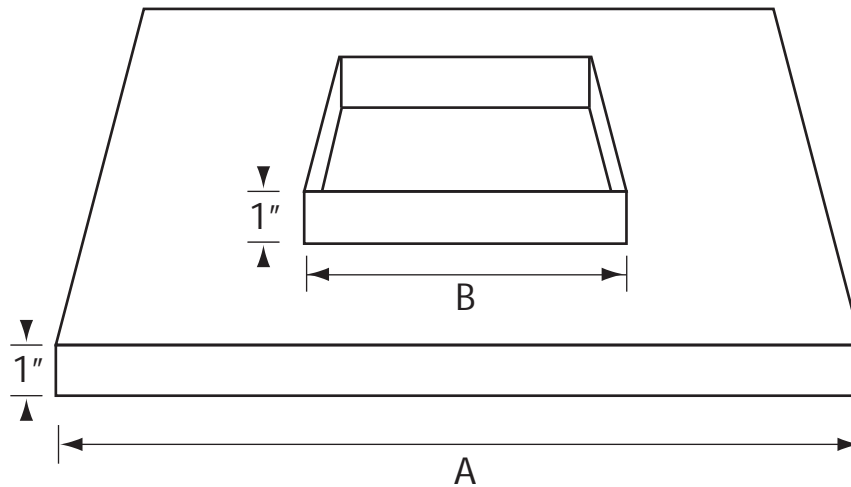


Finish		
<input type="checkbox"/> /M Mill Finish	<input type="checkbox"/> /W White (default)	<input type="checkbox"/> Custom (please specify) _____

Schedule type: _____
Job: _____
Architect: _____
Engineer: _____
Contractor: _____

Square to Square Transition

Material: 22 gauge steel.



✓	NTSS
---	------

✓	Listed A	Actual Interior Dimension
	2424	24" x 24"
	2222	22" x 22"
	1212	12" x 12"
	1010	10" x 10"

✓	Listed B	Actual Exterior Dimension
	2222	21 7/8" x 21 7/8"
	2020	19 7/8" x 19 7/8"
	1818	17 7/8" x 17 7/8"
	1616	15 7/8" x 15 7/8"
	1414	13 7/8" x 13 7/8"
	1212	11 7/8" x 11 7/8"
	1010	9 7/8" x 9 7/8"
	0808	7 7/8" x 7 7/8"
	0606	5 7/8" x 5 7/8"
	0404	3 7/8" x 3 7/8"



Finish		
<input type="checkbox"/> /M Mill Finish	<input type="checkbox"/> /W White (default)	<input type="checkbox"/> Custom (please specify)

Schedule type: _____

Job: _____

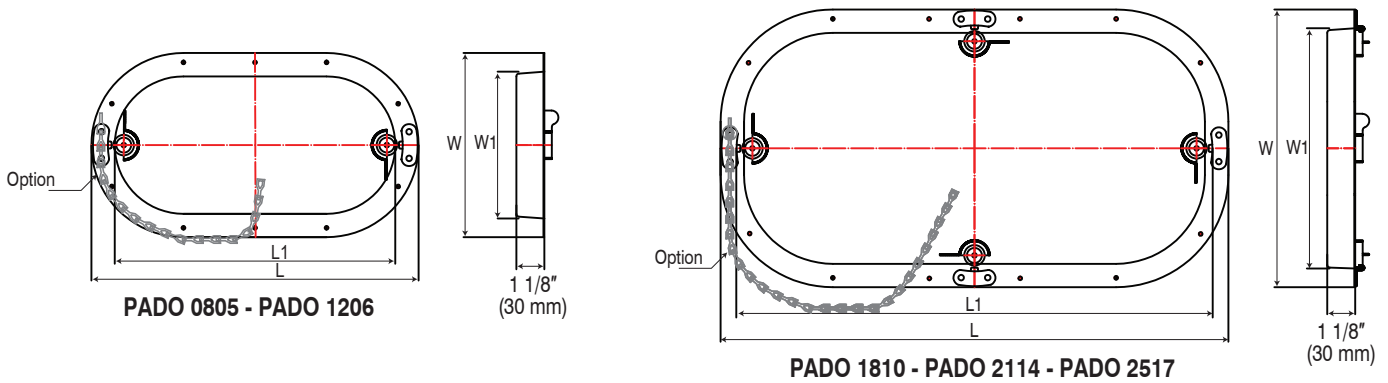
Architect: _____

Engineer: _____

Contractor: _____

Low Leakage Flat Oval Access Door

- Material:** 22ga (0.85) galvanized door panel and flanged frame (Die-formed).
- Hinge:** Plated steel camlock fasteners
- Insulation:** 1" (25) Styrofoam with a 22ga galvanized backing plate.
- Mounting:** 3/16" (5) dia. pre-punched holes on inner flange for surface mounting.
- Application:** Adaptable to all Ducts 5" (127) or Over.
- Template:** Layout template included on each box.



Dimensional Data :

Model	Nominal Size	L1	W1	L	W	Qty. /Box
PADO 0805	8" x 5" (200 mm x 125mm)	5 1/8" (205 mm)	5" (129 mm)	9 1/2" (241 mm)	6 1/2" (165 mm)	20
PADO 1206	12" x 6" (300mm x 150 mm)	12" 1/8" (309 mm)	6 1/2" (158 mm)	13 3/4" (349 mm)	7 3/4" (198 mm)	10
PADO 1810	18" x 10" (460 mm x 250 mm)	18 1/2" (462 mm)	10 1/4" (260 mm)	19 3/4" (502 mm)	11 7/8" (300 mm)	10
PADO 2114	21" x 14" (530 mm x 360 mm)	21 1/4" (540 mm)	14 1/8" (360 mm)	13 7/8" (580 mm)	15 3/4" (400 mm)	5
PADO 2517	25" x 17" (635 mm x 430 mm)	25 1/8" (640 mm)	17 1/4" (438 mm)	26 3/4" (680 mm)	19 7/8" (478 mm)	4

Option
<input type="checkbox"/> -SC Safety Chain

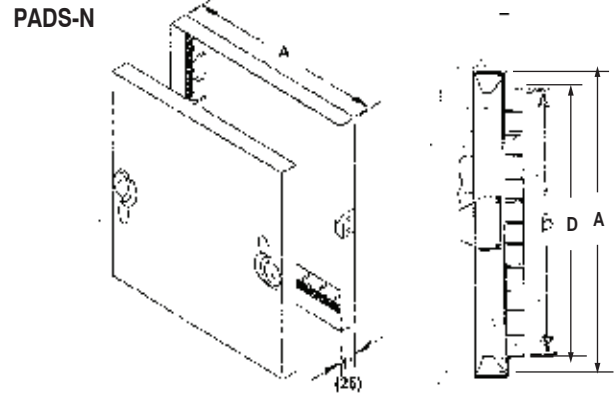
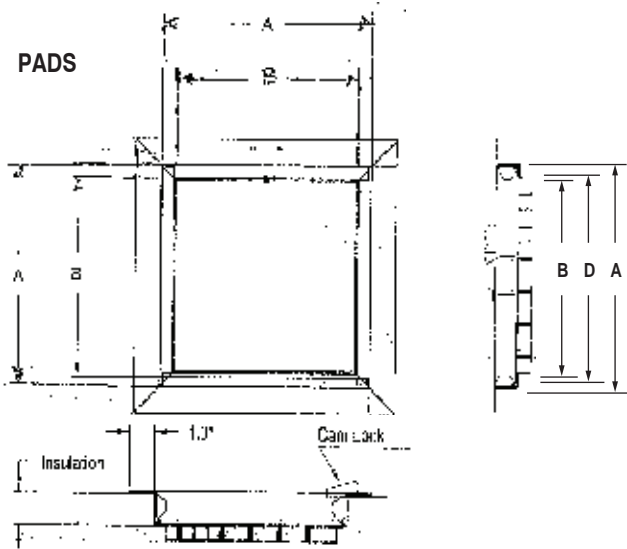
Model Description

Low leakage, quality and performance access door. Flat oval design, double flanged door with pre-punched holes on inner flange for surface mounting optimizes access area and simplifies installation.

Schedule type: _____
Job: _____
Architect: _____
Engineer: _____
Contractor: _____

Low Leakage Flat Oval Access Door

- Material:** 22 ga Steel Construction, Gasket behind frame and door for low leakage.
Hinge: Camlock Operation. 2 camlocks for 16" under, 4 over 16".
Insulation: 1" (25) Styrofoam.
Mounting: Notched knock-over.
Application: Adaptable to all Ducts 5" (127) or Over.



Dimensional Data (W x H):

Model	Nominal Size	A	B	D (Duct Dimensions)	Qty. /Box
PADS 0606	6" x 6" (152 mm x 152 mm)	6"	4 - 7/8" (124 mm)	5" (127 mm)	20
PADS 0808	8" x 8" (203 mm x 203 mm)	8"	6 - 7/8" (175 mm)	7" (178 mm)	20
PADS 1010	10" x 10" (254 mm x 254 mm)	10"	8 - 7/8" (226 mm)	9" (229 mm)	20
PADS 1212	12" x 12" (305 mm x 305 mm)	12"	10 - 7/8" (277 mm)	11" (280 mm)	10
PADS 1414	14" x 14" (356 mm x 356 mm)	14"	12 - 7/8" (328 mm)	13" (331 mm)	10
PADS 1616	16" x 16" (406 mm x 406 mm)	16"	14 - 7/8" (378 mm)	15" (381 mm)	10
PADS 1818	18" x 18" (457 mm x 457 mm)	18"	16 - 7/8" (429 mm)	17" (432 mm)	8
PADS 2020	20" x 20" (508 mm x 508 mm)	20"	18 - 7/8" (480 mm)	19" (483 mm)	6
PADS 2222	22" x 22" (559 mm x 559 mm)	22"	20 - 7/8" (531 mm)	21" (534 mm)	5
PADS 2424	24" x 24" (610 mm x 610 mm)	24"	22 - 7/8" (582 mm)	23" (585 mm)	4

Option

 -N No Flange

Schedule type: _____

Job: _____

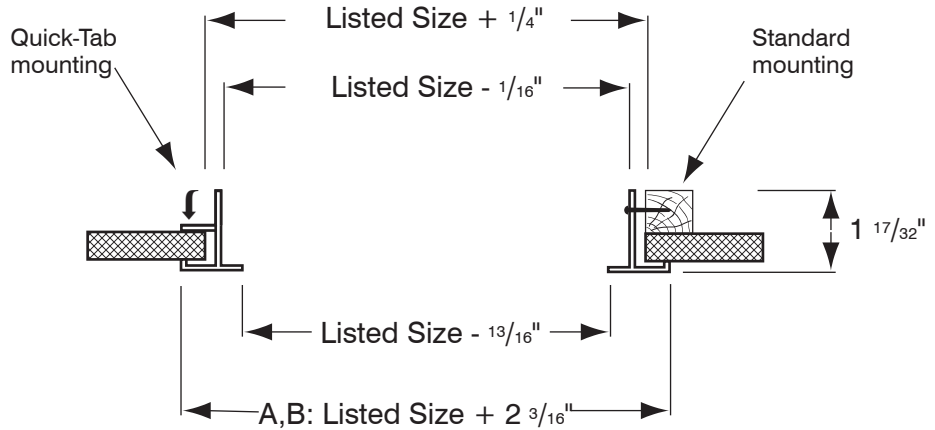
Architect: _____

Engineer: _____

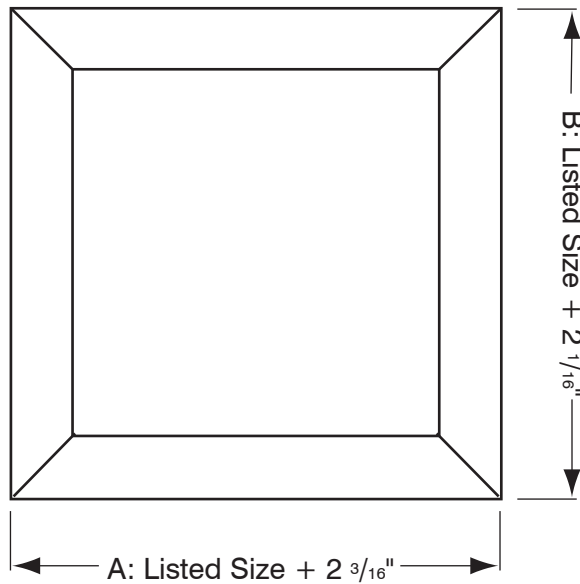
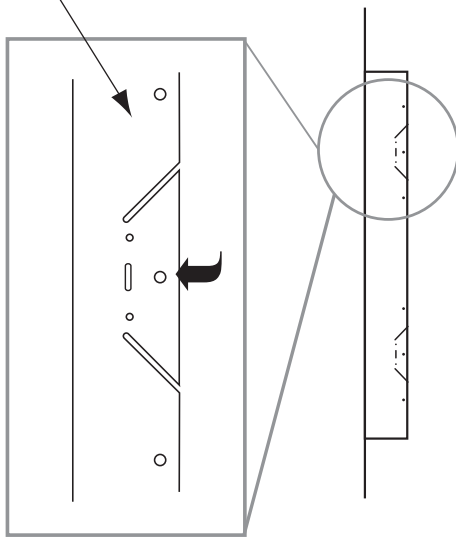
Contractor: _____

Plaster And Drywall Frame

Material: All aluminium construction.



PRACTICAL FEATURE:
Depress quick-tabs to sandwich drywall



✓	Model #	Face Dim. A x B
	PF 1212	14 1/16" x 14 1/16"
	PF 1224	14 1/16" x 26 1/16"
	PF 2424	26 1/16" x 26 1/16"
	PF 4824	50 1/16" x 26 1/16"

Finish	
<input type="checkbox"/> /w White (default)	<input type="checkbox"/> Custom (please specify) _____



Schedule type: _____

Job: _____

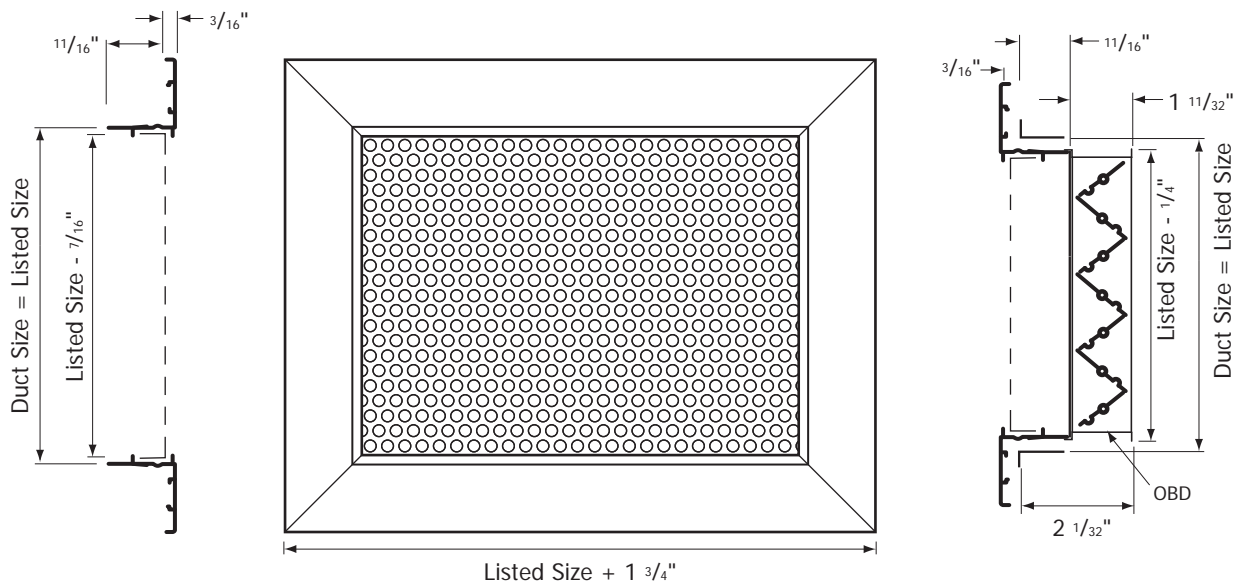
Architect: _____

Engineer: _____

Contractor: _____

Perforated Return Grille

- Material:** Extruded aluminum frame.
Coated steel perforated face with 3/16" diam. round holes on 1/4" staggered centers, affords 53% free area.
- Finish:** Powder paint white finish.
- Mounting:** Drywall mounting. Sidewall or ceiling.



Options			Fastening Method		
<input type="checkbox"/> -SF Supplied w/ sub frame	<input type="checkbox"/> -DS Debris (Bird) Screen	<input type="checkbox"/> -IS Insect Screen	<input type="checkbox"/> -1 No Fastening	<input type="checkbox"/> -2 Spring clip	<input type="checkbox"/> -3 Screw holes (Standard)
<input type="checkbox"/> -GK Flange Gasket	<input type="checkbox"/> -GN Neck Gasket				
Finish					
<input type="checkbox"/> /W White (default)	<input type="checkbox"/> /B Brushed Aluminium	<input type="checkbox"/> /M Mill Finish	<input type="checkbox"/> /L Brushed and Lacquered	<input type="checkbox"/> /Custom (Please Specify)	



Panel Option for T-bar lay-in Ceiling

W	Steel (WxH)		Aluminum (WxH)	
	H	<input type="checkbox"/> -X1212	<input type="checkbox"/> -Y1212	<input type="checkbox"/> -X2412
	<input type="checkbox"/> -X2424	<input type="checkbox"/> -Y2424	<input type="checkbox"/> -X4812	<input type="checkbox"/> -Y4812
	<input type="checkbox"/> -X4824	<input type="checkbox"/> -Y4824		

No mounting options available

Schedule type: _____

Job: _____

Architect: _____

Engineer: _____

Contractor: _____

SUBMITTAL SHEET

Perforated Face Return Diffuser with Molded Fiberglass Back Panel Fixed face

Material: Molded fiberglass back with aluminum foil vapor barrier scored for 6" to 14" D. Steel perforated face with 3/16" diam. holes on 1/4" staggered centers, affords 53% free area.

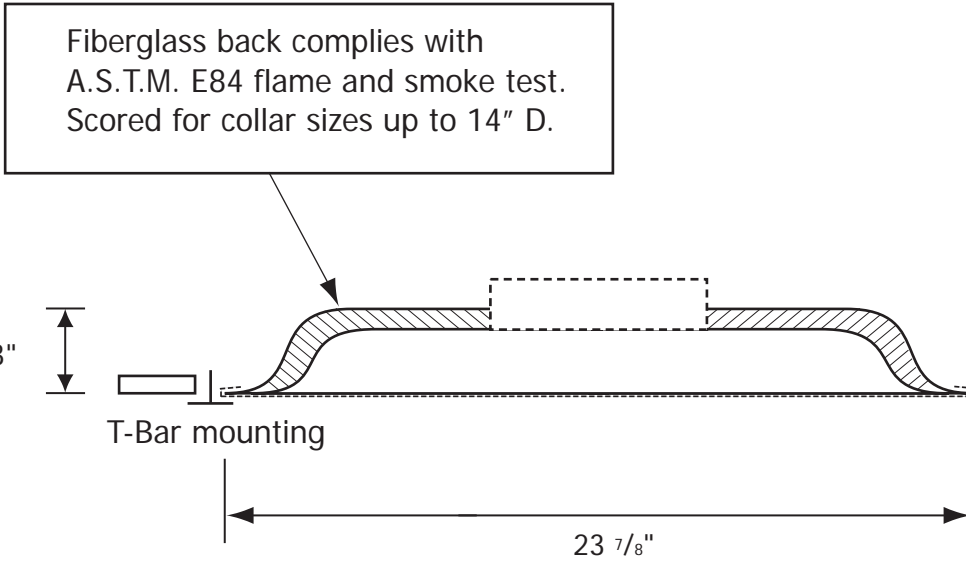
Finish: Powder paint coating - white.

Mounting: Lay-in T-bar ceiling.

Insulation: R6 Molded Fiberglass.



PRI



Finish	
<input type="checkbox"/> /W White (default)	<input type="checkbox"/> Custom (please specify)



Schedule type: _____

Job: _____

Architect: _____

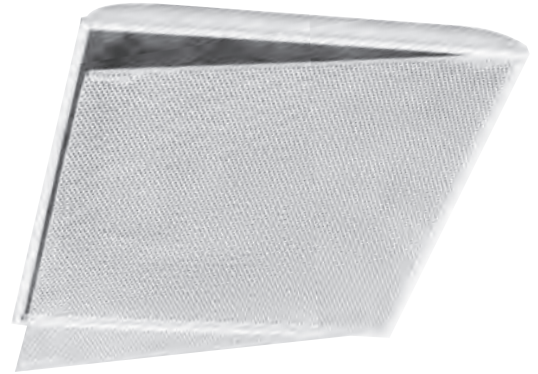
Engineer: _____

Contractor: _____

Perforated Face Filter Return with Molded Fiberglass Back Panel Hinged face

Material: Molded fiberglass back with aluminum foil vapor barrier scored for 6" to 14" D. in an extruded aluminum fixed frame. Steel perforated face with 3/16" diam. holes on 1/4" staggered centers, affords 53% free area and swings in and out of fixed frame.

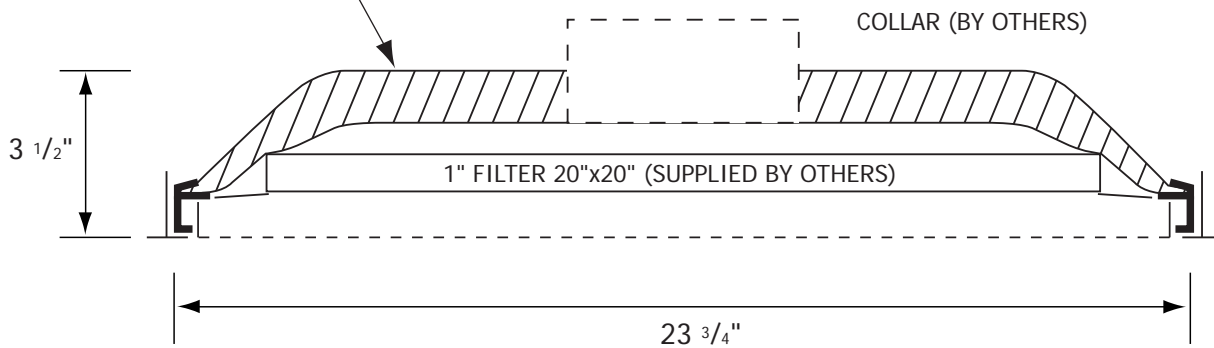
Finish: Powder paint coating - white.
Mounting: T-bar Lay-in ceiling.



PRIF

Fiberglass back complies with A.S.T.M. E84 flame and smoke test. Scored for collar sizes up to 14" D.

R4 R6



Finish	
<input type="checkbox"/> /W White (Default)	<input type="checkbox"/> /C Custom (Please Specify) _____



Schedule type: _____

Job: _____

Architect: _____

Engineer: _____

Contractor: _____

Perforated Face Return Diffuser Fixed face

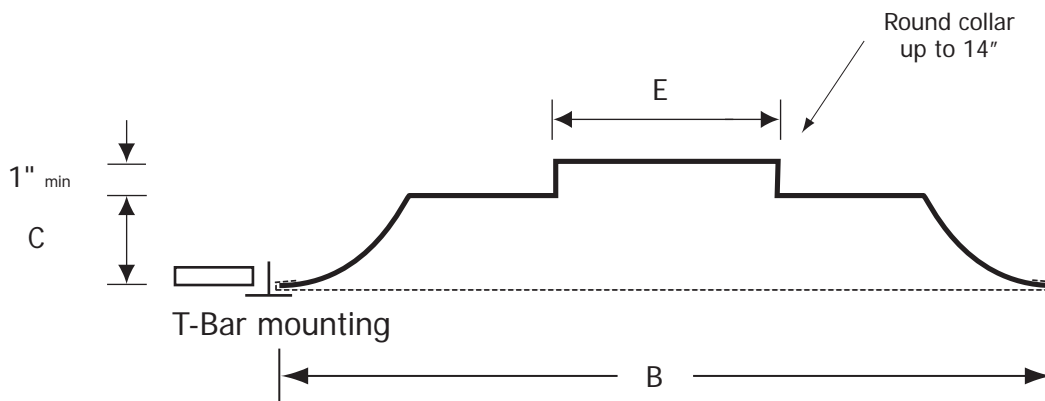
Material: Stamped heavy gauge steel back panel. Coated steel perforated face with 3/16" diam. round holes on 1/4" staggered centers, affords 53% free area.

Finish: Powder paint coating - white.

Mounting: Lay-in T-bar ceiling.



PRM



Optional fiberglass insulation on back panel, complies with A.S.T.M. E84 flame and smoke test. (Available only on models with 24" x 24" face)

R4 R6

✓	Model #	Duct Size	E	Face Dim B x B	C
	PRM 2406	6	5 7/8"	23 7/8" x 23 7/8"	2 7/8"
	PRM 2408	8	7 7/8"	23 7/8" x 23 7/8"	2 7/8"
	PRM 2410	10	9 7/8"	23 7/8" x 23 7/8"	2 7/8"
	PRM 2412	12	11 7/8"	23 7/8" x 23 7/8"	2 7/8"
	PRM 2414	14	13 7/8"	23 7/8" x 23 7/8"	2 7/8"
	PRM 1206	6	5 7/8"	11 7/8" x 11 7/8"	1 3/4"
	PRM 1208	8	7 7/8"	11 7/8" x 11 7/8"	1 3/4"

Finish

/W White (Default)
 /C Custom (Please Specify)



Schedule type: _____

Job: _____

Architect: _____

Engineer: _____

Contractor: _____

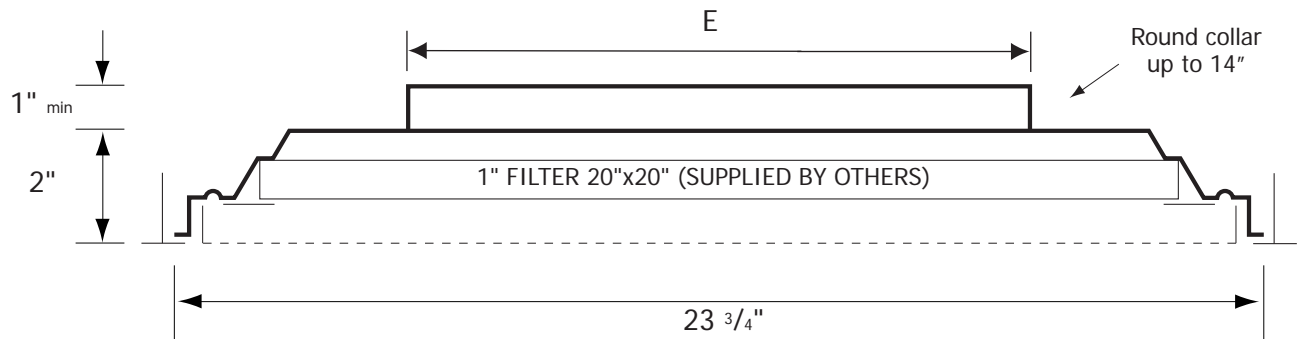
Perforated Face Filter Return with Steel Back Panel Hinged face

Material: Stamped heavy gauge steel back panel with reinforcing corners. Steel perforated face with 3/16" diam. holes on 1/4" staggered centers, affords 53% free area and swings in and out of fixed frame for access to 20"x20" filter by others.

Finish: Powder paint coating - white.
Mounting: T-bar Lay-in ceiling.



PRMF



✓	Model #	Duct Size	E	Face Dim
	PRMF 2406	6	5 7/8"	23 3/4" x 23 3/4"
	PRMF 2408	8	7 7/8"	23 3/4" x 23 3/4"
	PRMF 2410	10	9 7/8"	23 3/4" x 23 3/4"
	PRMF 2412	12	11 7/8"	23 3/4" x 23 3/4"
	PRMF 2414	14	13 7/8"	23 3/4" x 23 3/4"

Schedule type: _____
Job: _____
Architect: _____
Engineer: _____
Contractor: _____

SUBMITTAL SHEET

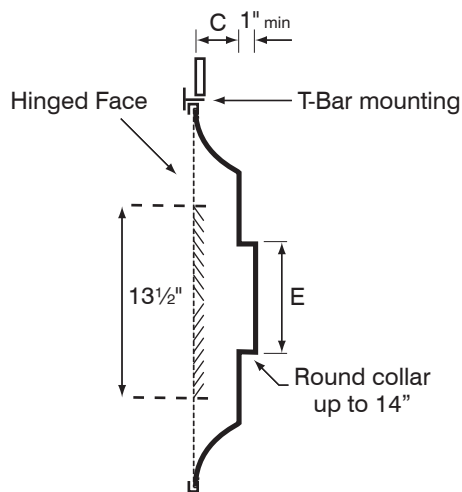
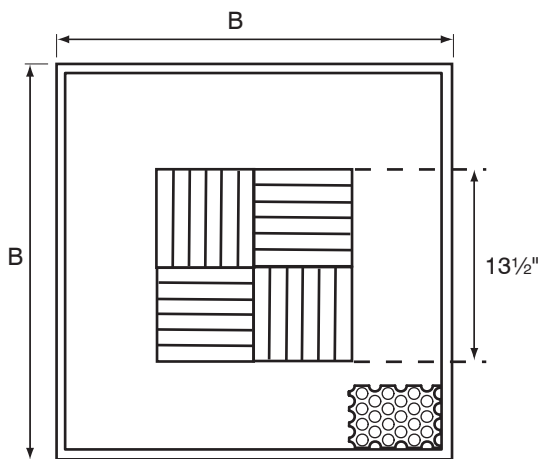
Perforated Face Return with Steel Back Panel & Directional Louver Deflectors Hinged face

Material: Stamped heavy gauge steel back panel with reinforcing corners. Steel perforated face with 3/16" diam. holes on 1/4" staggered centers, affords 53% free area and swings in and out of fixed frame for access to 20"x20" filter by others.

Finish: Powder paint coating - white.
Mounting: T-bar Lay-in ceiling.



PRMFL



✓	Model #	Duct Size	E	Face Dim
	PRMFL 2406	6	5 7/8"	23 3/4" x 23 3/4"
	PRMFL 2408	8	7 7/8"	23 3/4" x 23 3/4"
	PRMFL 2410	10	9 7/8"	23 3/4" x 23 3/4"
	PRMFL 2412	12	11 7/8"	23 3/4" x 23 3/4"
	PRMFL 2414	14	13 7/8"	23 3/4" x 23 3/4"

Schedule type: _____

Job: _____

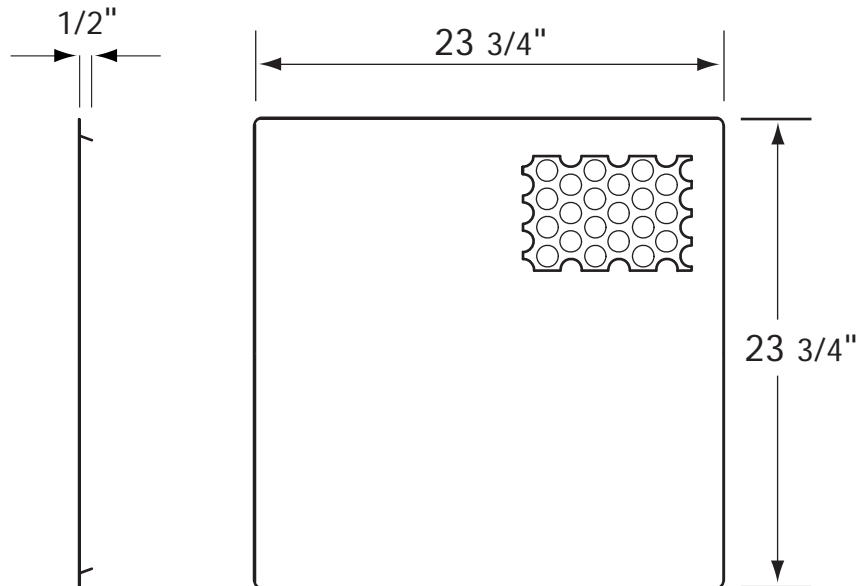
Architect: _____

Engineer: _____

Contractor: _____

Ceiling Return Air Diffuser

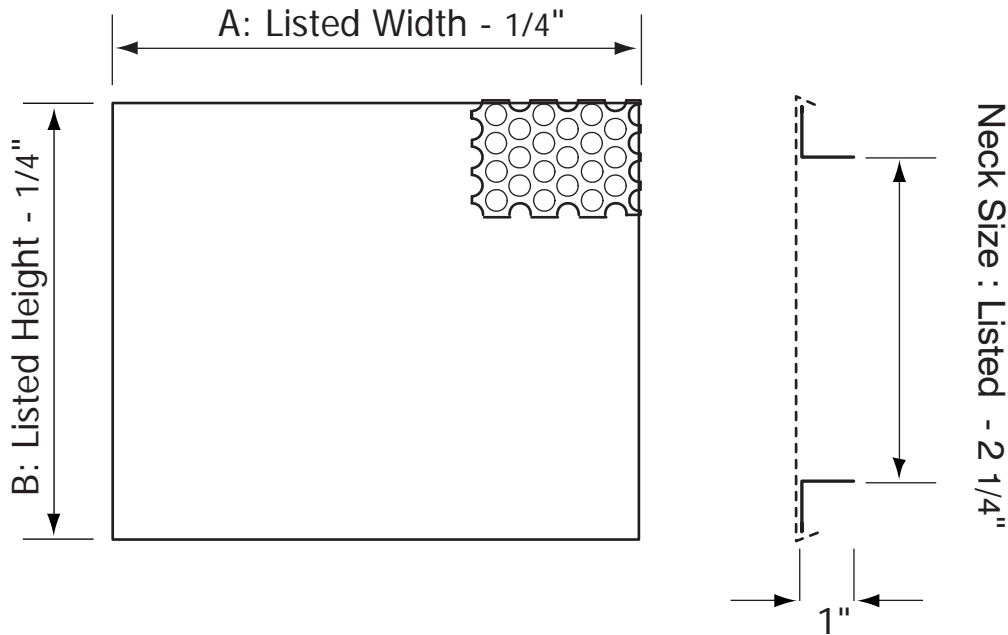
- Material:** Metal face construction
Full face perforated panel with 3/16" holes
on 1/4" staggered and 51% open area.
- Finish:** Bake white paint finish.
- Mounting:** Lay-in T-bar ceiling.



Schedule type: _____
Job: _____
Architect: _____
Engineer: _____
Contractor: _____

Ceiling Return Air Diffuser

- Material:** High capacity all steel construction.
Full face perforated panel with 3/16" holes on 1/4" staggered centres and 51% open area.
- Finish:** Powder paint white finish.
- Mounting:** For surface mounting or T-bar lay-in ceiling grids.



✓	Model #	Face Dim. A x B
	PRT 1212	11 3/4" x 11 3/4"
	PRT 2412	23 3/4" x 11 3/4"
	PRT 2424	23 3/4" x 23 3/4"

Finish		
<input type="checkbox"/> /W White (default)	<input type="checkbox"/> /M Mill Finish	<input type="checkbox"/> Custom (please specify) _____

Schedule type: _____
Job: _____
Architect: _____
Engineer: _____
Contractor: _____

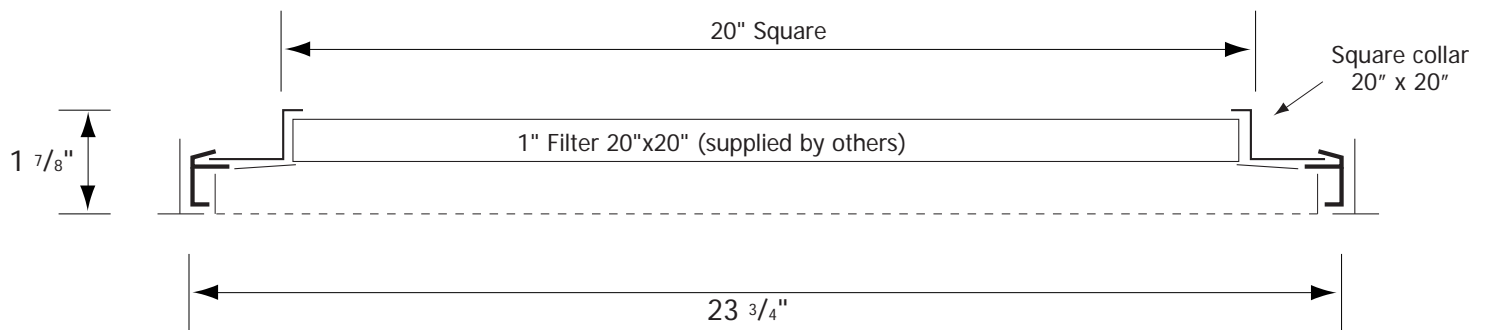
Perforated Face Filter Return with 20" X 20" Filter frame Hinged face

Material: Steel filter frame will accept standard 1" filter. Steel perforated face with 3/16" diam. holes on 1/4" staggered centers, affords 53% free area and swings in and out of fixed frame for access to 20"x20" filter by others.

Finish: Powder paint coating - white.
Mounting: T-bar Lay-in ceiling.



PRTF



Finish	
<input type="checkbox"/> /W White (Default)	<input type="checkbox"/> /C Custom (Please Specify) _____



Schedule type: _____

Job: _____

Architect: _____

Engineer: _____

Contractor: _____

Perforated Face Supply Diffuser with Molded Fiberglass Back Panel Fixed face - baffle deflector

Material: Molded fiberglass back with aluminum foil vapor barrier scored for 6" to 14" D. Steel perforated face with 3/16" diam. holes on 1/4" staggered centers, affords 53% free area.

Finish: Powder paint coating - white.

Air pattern: Fixed horizontal 360° diffusion.

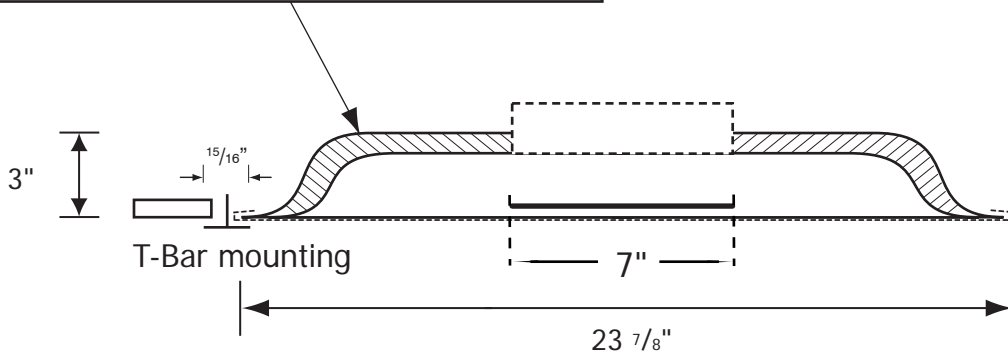
Mounting: Lay-in T-bar ceiling.

Insulation: R6 Molded Fiberglass.



PSI

Fiberglass back complies with A.S.T.M. E84 flame and smoke test. Scored for collar sizes up to 14" D.



Mounting	
<input type="checkbox"/> -NT	Narrow T-bar

Finish	
<input type="checkbox"/> /W	White (Default)
<input type="checkbox"/> /C	Custom (Please Specify)



Schedule type: _____

Job: _____

Architect: _____

Engineer: _____

Contractor: _____

Perforated Face Supply Diffuser with Molded Fiberglass Back Panel Fixed face - directional louvers deflector

Material: Molded fiberglass back with aluminum foil vapor barrier scored for 6" to 14" D. Steel perforated face with 3/16" diam. holes on 1/4" staggered centers, affords 53% free area.

Finish: Powder paint coating - white.

Air pattern: Fixed horizontal 360° diffusion.

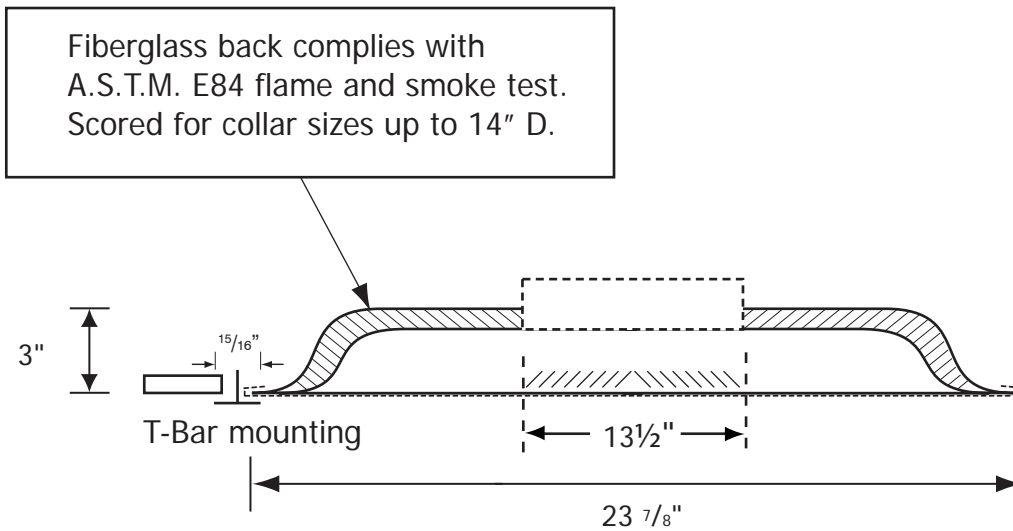
Mounting: Lay-in T-bar ceiling.

Insulation: R6 Molded Fiberglass.



PSIL

SUBMITTAL SHEET



Mounting
<input type="checkbox"/> -NT Narrow T-bar

Finish	
<input type="checkbox"/> /W White (Default)	<input type="checkbox"/> /C Custom (Please Specify)



Schedule type: _____

Job: _____

Architect: _____

Engineer: _____

Contractor: _____

Perforated Face Supply Diffuser Fixed face - baffle deflector

Material: Stamped heavy gauge steel back panel.
Coated steel perforated face with 3/16" diam. round holes on 1/4" staggered centers, affords 53% free area.

Finish: Powder paint coating - white.

Air pattern: Fixed horizontal 360° diffusion.

Mounting: Lay-in T-bar ceiling.

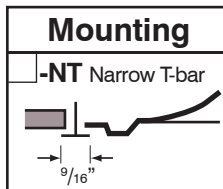
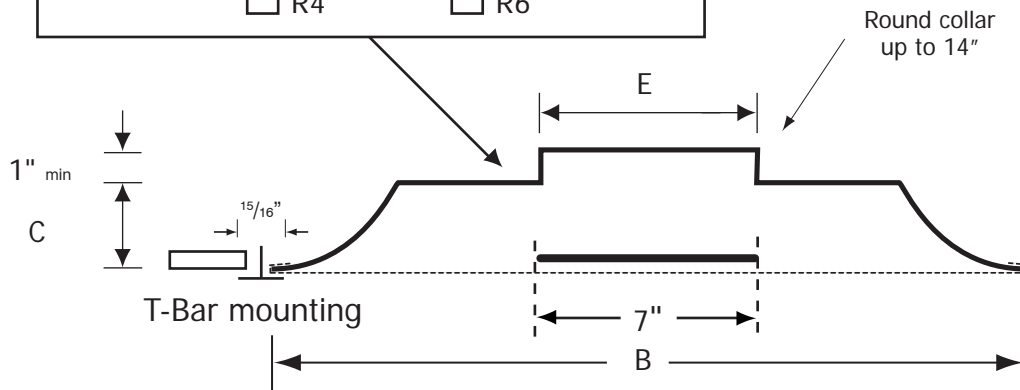


PSM

Optional fiberglass insulation on back panel, complies with A.S.T.M. E84 flame and smoke test. (Available only on models with 24" x 24" face)

R4

R6



Finish	
<input type="checkbox"/> /W White (Default)	<input type="checkbox"/> /C Custom (Please Specify)



✓	Model #	Duct Size	E	Face Dim B x B	C
	PSM 2406	6	5 7/8"	23 7/8" x 23 7/8"	2 7/8"
	PSM 2408	8	7 7/8"	23 7/8" x 23 7/8"	2 7/8"
	PSM 2410	10	9 7/8"	23 7/8" x 23 7/8"	2 7/8"
	PSM 2412	12	11 7/8"	23 7/8" x 23 7/8"	2 7/8"
	PSM 2414	14	13 7/8"	23 7/8" x 23 7/8"	2 7/8"

Schedule type: _____

Job: _____

Architect: _____

Engineer: _____

Contractor: _____

Perforated Face Supply Diffuser Fixed face - directional louvers deflectors

Material: Stamped heavy gauge steel back panel. Coated steel perforated face with 3/16" diam. round holes on 1/4" staggered centers, affords 53% free area.

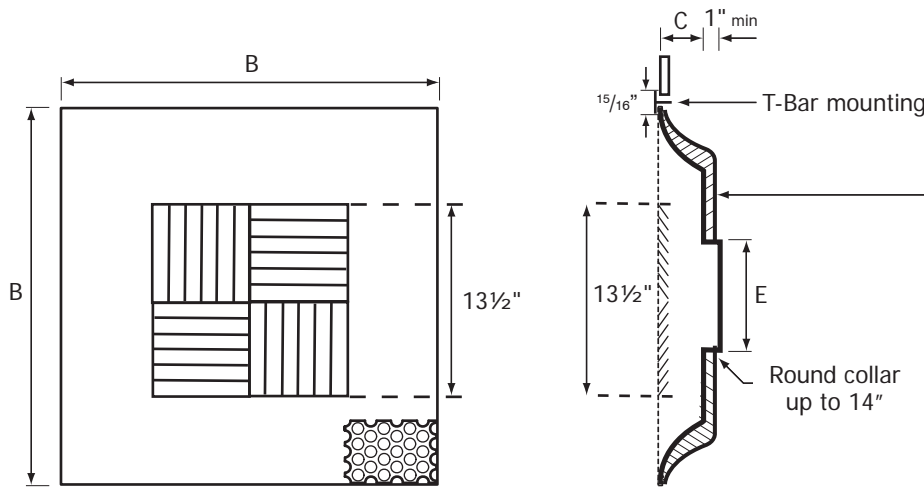
Finish: Powder paint coating - white.

Air pattern: Fixed horizontal 360° diffusion.

Mounting: Lay-in T-bar ceiling.

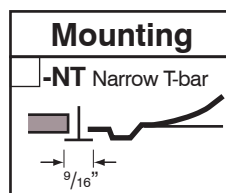


PSML



Optional fiberglass insulation on back panel, complies with A.S.T.M. E84 flame and smoke test. (Available only on models with 24" x 24" face)

 R4

 R6


Finish	
<input type="checkbox"/> /W White (Default)	<input type="checkbox"/> /C Custom (Please Specify)



✓	Model #	Duct Size	E	Face Dim B x B	C
	PSML 2406	6	5 7/8"	23 7/8" x 23 7/8"	2 7/8"
	PSML 2408	8	7 7/8"	23 7/8" x 23 7/8"	2 7/8"
	PSML 2410	10	9 7/8"	23 7/8" x 23 7/8"	2 7/8"
	PSML 2412	12	11 7/8"	23 7/8" x 23 7/8"	2 7/8"
	PSML 2414	14	13 7/8"	23 7/8" x 23 7/8"	2 7/8"

Schedule type: _____

Job: _____

Architect: _____

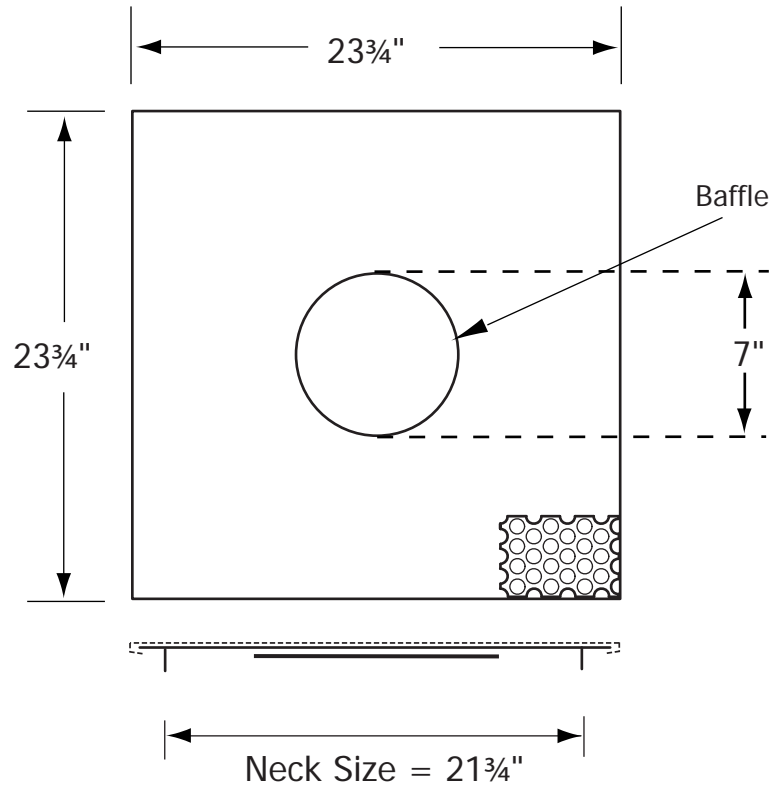
Engineer: _____

Contractor: _____

SUBMITTAL SHEET

Perforated Ceiling Supply Diffuser with Square Neck Fixed Face - Round Baffle deflector

- Description:** Full face perforated panel with 3/16" holes on 1/4" staggered centers, affords 53% open area. Round baffle.
- Material:** All steel construction.
- Air Pattern:** Fixed horizontal 360° diffusion.
- Finish:** Powder paint white finish.
- Mounting:** For surface mounting or T-bar lay-in ceiling grids.



Model #	Neck Size	Face Dim.
PST 2424	21 ³ / ₄	23 ³ / ₄ " x 23 ³ / ₄ "

Finish	
<input type="checkbox"/> /W White (Default)	<input type="checkbox"/> /C Custom (Please Specify) _____



Schedule type: _____

Job: _____

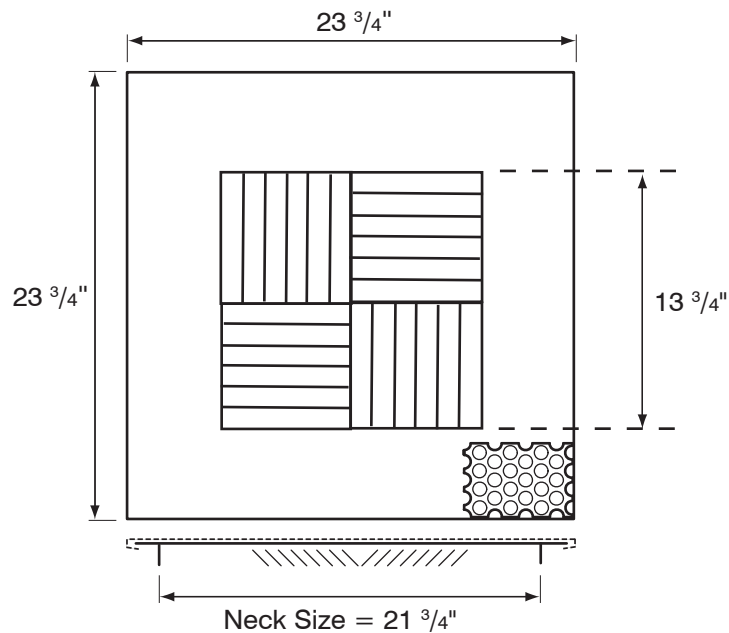
Architect: _____

Engineer: _____

Contractor: _____

Perforated Ceiling Supply Diffuser with Square Neck Fixed Face - Louver deflectors

- Description:** Full face perforated panel with 3/16" holes on 1/4" staggered centers, affords 53% open area.
- Material:** All steel construction.
- Air Pattern:** 4 fixed directional louvers, horizontal 360° diffusion.
- Finish:** Powder paint coating - white.
- Mounting:** For surface mounting or T-bar lay-in ceiling grids.



Finish

<input type="checkbox"/> /W White (Default)	<input type="checkbox"/> /C Custom (Please Specify) _____
--	--



Schedule type: _____

Job: _____

Architect: _____

Engineer: _____

Contractor: _____

Model #	Neck Size	Face Dim.
PSTL 2424	$21 \frac{3}{4}"$	$23 \frac{3}{4}" \times 23 \frac{3}{4}"$

SUBMITTAL SHEET

RAF / RAF7 Series

Rev. 2

All dimensions are in inches
*1/4" bigger than model number indicates on height

SUBMITTAL SHEET

RAF SERIES - High-End Architectural Floor Grilles

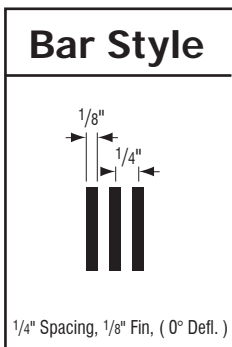
- Material:** Aluminum
- Finish:** Brushed Aluminum & Powder Coated Lacquer
- Features:** Removable Core, Reinforced for Floor



RAF

Opposed Blade Damper (optional):
Galvanized steel construction
Key-operated

Other Styles Available: Order using ALB model and switch options
Equivalent RAF = ALB10-F-1-RM-RF xx xx /L
Equivalent RAF7 = ALB17-F-1-RM-RF xx xx /L

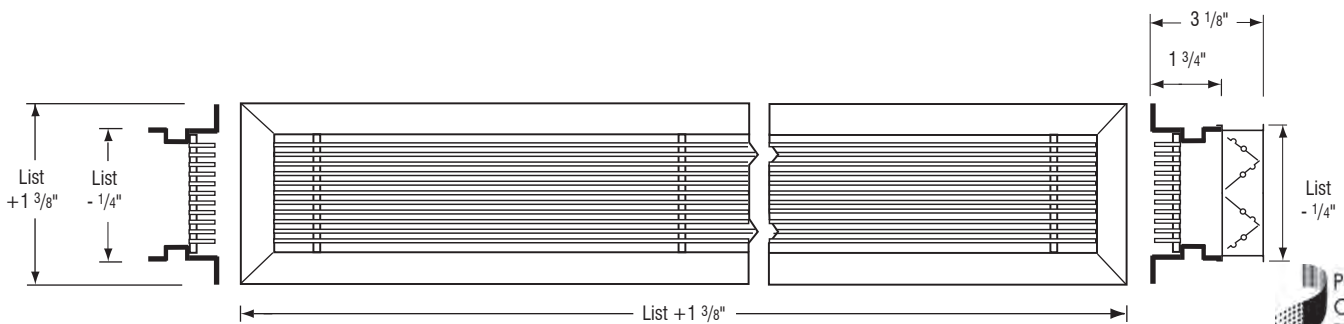


RAF Residential Architectural Floor Grille

✓	Model #	List/Duct Size
	*RAF 0210	2.25" x 10"
	*RAF 0212	2.25" x 12"
	RAF 0310	3" x 10"
	RAF 0312	3" x 12"
	RAF 0408	4" x 8"
	RAF 0410	4" x 10"
	RAF 0412	4" x 12"
	RAF 0414	4" x 14"
	RAF 0612	6" x 12"
	RAF 0614	6" x 14"

RAF7 Residential Architectural Floor Register with N7 OBD

✓	Model #	List/Duct Size
	*RAF7 0210	2.25" x 10"
	*RAF7 0212	2.25" x 12"
	RAF7 0310	3" x 10"
	RAF7 0312	3" x 12"
	RAF7 0408	4" x 8"
	RAF7 0410	4" x 10"
	RAF7 0412	4" x 12"
	RAF7 0414	4" x 14"
	RAF7 0612	6" x 12"
	RAF7 0614	6" x 14"



Schedule Type: _____

Project: _____

Architect: _____

Engineer: _____

Contractor: _____

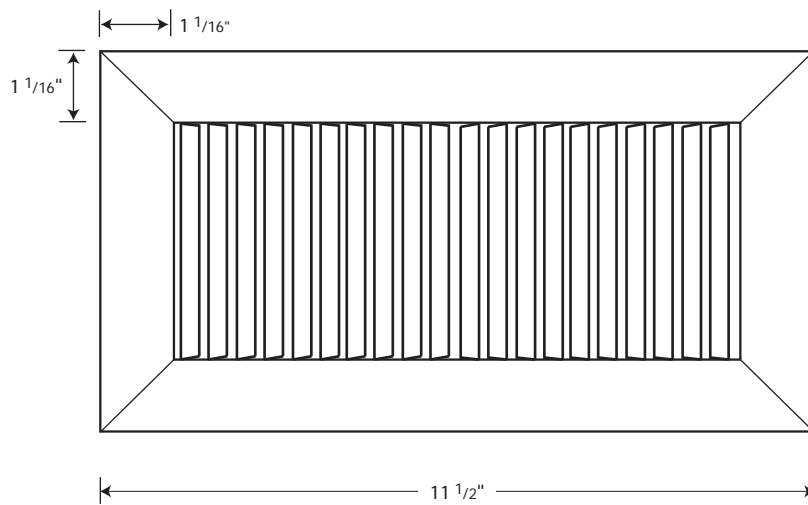
REAL SERIES - High-End Residential Floor Grilles

- Material:** Aluminum
- Finish:** Various finishes available - See Finish Chart
Anodized finish is standard
- Air Pattern:** 5 way pattern (-30°, -15°, 0, 15°, 30°)

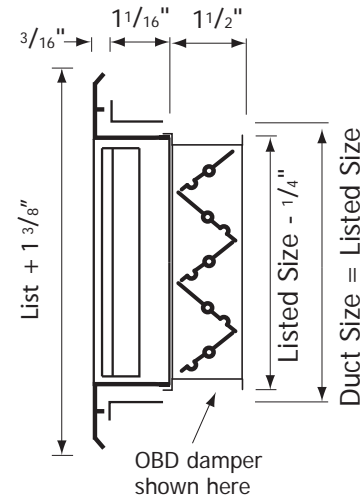


SUBMITTAL SHEET

REAL
Residential Floor Grille



REAL Residential Floor Bar Grille



REAL Residential Floor Bar Grille

REAL7 Residential Floor Bar Register with opposed blade damper



Model #	Neck Size"	Model #	Neck Size"
REAL 0310	3 x 10	REAL7 0310	3 x 10
REAL 0408	4 x 8	REAL7 0408	4 x 8
REAL 0410	4 x 10	REAL7 0410	4 x 10
REAL 0412	4 x 12	REAL7 0412	4 x 12
REAL 0414	4 x 14	REAL7 0414	4 x 14
REAL 0612	6 x 12	REAL7 0612	6 x 12
REAL 0614	6 x 14	REAL7 0614	6 x 14

Finish		
<input type="checkbox"/> /A Anodized (default)	<input type="checkbox"/> /M Mill Finish	<input type="checkbox"/> Custom (please specify)

Schedule Type: _____

Project: _____

Architect: _____

Engineer: _____

Contractor: _____

SQUARE DIFFUSERS



MODELS ADF3, ADF3D & ADF3I 3 CONE ALUMINUM DIFFUSERS

MODEL **ADF3** - Fixed horizontal pattern

MODEL **ADF3D**- Fixed horizontal pattern, 2" high collar

MODEL **ADF3I** - Fixed horizontal pattern, Insulated

Airvector's 3 Cone Aluminum Supply Diffusers are recommended for heating, ventilating, and cooling. The diffusers' integrated round-neck-to-square-face construction provides a 360° horizontal air diffusion pattern similar to a full round diffuser. The ADF3I is supplied with R6 insulation and does not include an integrated collar. R4 and R6 are optional for ADF3 and ADF3D.

High diffusion induction rates result in rapid temperature and velocity equalization of the mixed air mass well above the zone of occupancy. Horizontal performance assures confident use of a cooling temperature differential of 30° and greater at a predicted low air motion of 35 fpm in the zone of occupancy. ADF3 supply diffusers perform efficiently with air loadings of 6 to 30 air changes per hour (based on a 10 ft. ceiling height), and a sound level range of NC 25 to 35.

Highlights

- Heavy-gauge all-aluminum construction
- Powder paint coating - White (Custom Finishes Avail.)
- Matching N4 and N5 OBDs available
- OBD accessible through diffuser face

Listed Size	Neck Dia	Nominal Face Size	Overall Face Size "B"	Drywall Ceiling Opening
1206*	6	12 x 12	11 ³ / ₄ x 11 ³ / ₄	10 ¹ / ₂ x 10 ¹ / ₂
1208*	8	12 x 12	11 ³ / ₄ x 11 ³ / ₄	10 ¹ / ₂ x 10 ¹ / ₂
2406	6	24 x 24	23 ³ / ₄ x 23 ³ / ₄	22 ¹ / ₂ x 22 ¹ / ₂
2408	8	24 x 24	23 ³ / ₄ x 23 ³ / ₄	22 ¹ / ₂ x 22 ¹ / ₂
2410	10	24 x 24	23 ³ / ₄ x 23 ³ / ₄	22 ¹ / ₂ x 22 ¹ / ₂
2412	12	24 x 24	23 ³ / ₄ x 23 ³ / ₄	22 ¹ / ₂ x 22 ¹ / ₂
2414*	14	24 x 24	23 ³ / ₄ x 23 ³ / ₄	22 ¹ / ₂ x 22 ¹ / ₂

* Only available with ADF3

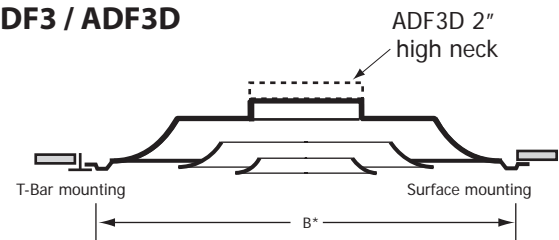


ADF3

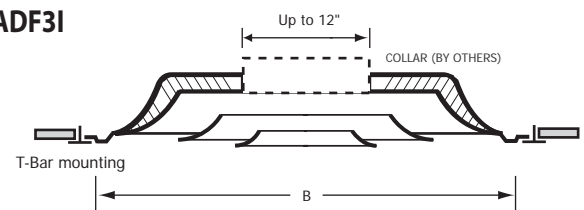
HANDY FEATURES

- One standard model suits both T-Bar and Drywall installations using rigid ducts
- Compatible with Airvector's exclusive Easy Install PF frame
- Core is easily removable without tools to facilitate access to duct.

ADF3 / ADF3D



ADF3I



DATA SHEET

ENGINEERING PERFORMANCE DATA

MODELS ADF3, ADF3D & ADF3I

3 CONE



AIRVECTOR®

12" x 12" face

SIZE (inches)	Neck Velocity (fpm)	400	500	600	700	800	1000	1200	1400	1600
	Velocity Pressure (in H ₂ O)	.010	.016	.022	.031	.041	.062	.090	.122	.160
6	CFM	78	98	118	137	157	196	235	274	313
	Total Pressure	.02	.03	.04	.06	.07	.10	.16	.22	.29
	NC	< 20	< 20	< 20	< 20	< 20	25	29	34	40
	Throw (ft)	2-3-6	3-4-7	4-5-9	4-5-10	5-6-11	6-8-12	7-9-13	8-10-15	9-11-16
8	CFM	140	175	209	244	279	349	419	489	559
	Total Pressure	.03	.04	.06	.07	.09	.14	.20	.28	.38
	NC	< 20	< 20	< 20	< 20	< 20	29	35	41	45
	Throw (ft)	2-4-7	3-5-9	4-7-10	5-8-11	6-9-12	7-10-14	8-12-17	10-12-18	11-14-20

24" x 24" face

SIZE (inches)	Neck Velocity (fpm)	400	500	600	700	800	1000	1200	1400	1600
	Velocity Pressure (in H ₂ O)	.010	.016	.022	.031	.041	.062	.090	.122	.160
6	CFM	78	98	118	137	157	196	235	274	313
	Total Pressure	.02	.03	.04	.05	.07	.10	.14	.19	.24
	NC	< 20	< 20	< 20	< 20	< 20	22	28	32	36
	Throw (ft)	1-2-4	1-3-4	2-3-5	2-3-6	3-4-7	4-6-8	5-7-10	6-9-11	7-9-12
8	CFM	140	175	209	244	279	349	419	489	559
	Total Pressure	.02	.03	.04	.05	.08	.10	.15	.20	.25
	NC	< 20	< 20	< 20	< 20	< 20	26	31	36	41
	Throw (ft)	2-3-5	2-3-7	3-4-8	3-5-8	4-6-9	5-7-11	6-9-13	7-10-14	8-11-17
10	CFM	218	273	327	382	436	545	654	763	872
	Total Pressure	.02	.03	.04	.05	.08	.12	.17	.24	.30
	NC	< 20	< 20	< 20	< 20	22	29	34	38	43
	Throw (ft)	3-4-6	4-5-8	4-6-10	5-7-12	6-8-14	7-9-15	8-11-16	9-12-17	10-13-19
12	CFM	314	393	471	550	628	785	941	1099	1246
	Total Pressure	.02	.04	.05	.07	.09	.14	.20	.27	.36
	NC	< 20	< 20	< 20	20	23	39	36	41	46
	Throw (ft)	4-5-9	5-6-10	6-7-11	6-8-13	7-9-15	8-11-18	10-13-21	12-16-22	13-18-21
14	CFM	492	615	738	861	984	1230	1476	1722	1968
	Total Pressure	.03	.04	.06	.08	.10	.18	.23	.30	.40
	NC	< 20	< 20	< 20	21	25	33	38	43	48
	Throw (ft)	4-6-10	5-6-11	6-8-14	7-10-16	8-11-18	10-14-20	12-16-22	14-19-24	15-20-26

NC Value based on 10 db room attenuation.

Throw Values are based on isothermal air and terminal velocities of 150 fpm, 100 fpm & 75 fpm respectively.

Total Pressure the sum of static pressure plus velocity pressure and is given in inches w.g.

HOW TO ORDER ADF3 & ADF4 SERIES

ADF3-R4-W3 2408 /W

MODEL SERIES

- 3 Cone Alum Fixed **ADF3**
- 3 Cone Alum Fixed, ... 2" Neck **ADF3D**
- 4 Cone Alum Fixed **ADF4**
- 4 Cone Alum Fixed, ... 2" Neck **ADF4D**

INSULATION (OPTIONAL)

- Default is uninsulated
- R4.2 Taped Insulation **-R4**
- R6 Taped Insulation **-R6**

DIRECTION (OPTIONAL)

- Default is 4 Way
- 1 Way **-W1**
- 2 Way Corner **-WC**
- 2 Way Opposed **-WO**
- 3 Way **-W3**

FINISH (OPTIONAL)
Default is White (/W)
See chart for more

NECK DIAMETER
In Inches
06-08-10-12-14"

FACE DIMENSIONS
12" x 12" 12
24" x 24" 24

HOW TO ORDER ADF3I & ADF4I

ADF3I /W

MODEL SERIES

- 3 Cone Alum **ADF3I**
- 4 Cone Alum **ADF4I**

FINISH (OPTIONAL)
Default is White (/W)
See chart for more

LINEAR BAR GRILLES



ALB SERIES Architectural Linear Bar Grilles

For Ceiling, Sidewall, Sill, and Floor Installation

Series ALB (Architectural Linear Bar) Grilles are designed for installation in the sidewall, sill, floor, and ceiling, and are recommended for supplying heated, ventilated, or cooled air, and for returning or exhausting room air. Their reliable performance assures confident use of cooling temperature differentials up to 25°F at predicted low air motion of 35 fpm in the zone of occupancy. Series ALB Grilles perform efficiently with air loadings of 1 to 2½ CFM per sq.ft. and a sound level range of NC 25 to 35.

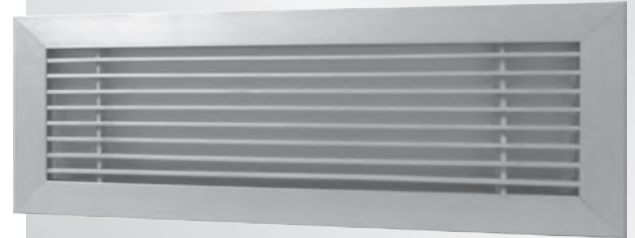
When installed in the sidewall near the ceiling, Series ALB Grilles provide a horizontal pattern above the occupied zone. Core deflections of 15° or 30° direct the air path upward to overcome the drop effect resulting from cool primary air. Use of the deflected cores also improves sight-tightness of the grille face.

When installed in the top of a sill or enclosure, Series ALB Grilles provide a vertical up pattern which is effective in overcoming uncomfortable cold downdrafts and offsetting the radiant effect of glass surfaces. Core deflections of 0°, 15°, and 30° directed toward the glass surface provide upward airflow to the ceiling toward the interior zone.

When installed in the ceiling, Series ALB Grilles provide a vertical downward air pattern which is effective in projection heating and cooling the building perimeter from ceiling heights above 12-15 ft. Application of downflow primary air should be limited in volume to insure against excessive drafts at the end of the throw. Core deflections of 0°, 15°, and 30° direct the air path angularly downward as required.

For floor installations, grilles are specially reinforced. Maximum listed width is 6" for constant traffic areas and areas where heavy loads such as copiers or other equipment may be rolled across grilles. In no case should equipment be "parked" on grilles. For occasional traffic areas, maximum listed width is 8". Maximum listed length is 60".

Series ALB Grilles are fabricated of high-quality aluminum extrusions. Components are mechanically interlocked for a blemish-free appearance. Key-ways and splice plates facilitate hair-line butting of 5 ft. sections to form continuous lengths. Opposable Blade Volume dampers are integrally fastened to Series ALB Grilles. Adjustable Air Equalizing Grids provide spread pattern deflection to shorten the throw. Friction spring fasteners on margins hold grilles to duct collar in sill installations. Mitered corner sections are furnished in one piece.



ALB10

FEATURES

- Six bar styles including Pencil Proof
- 0°, 15°, 30° bar deflections
- Friction margin spring fasteners to hold grilles to duct collars for sill installations
- Extruded Aluminum construction: Mechanical assembly
- Butts available in continuous lengths with key-way splices. Factory cut or field cut lengths for precise installation
- White color default. Available in Black colour, Silver aluminium colour, Brushed & lacquered finish, Mill finish, Primer, Satin Anodized finish. Custom colors and finishes available on request.

Accessories/Options

- Opposable Blade Damper
- Air Equalizing Grid (min. width 4")
- Removable core
- Reinforced floor application (max. width 8")
- Mitered corner sections furnished as on piece

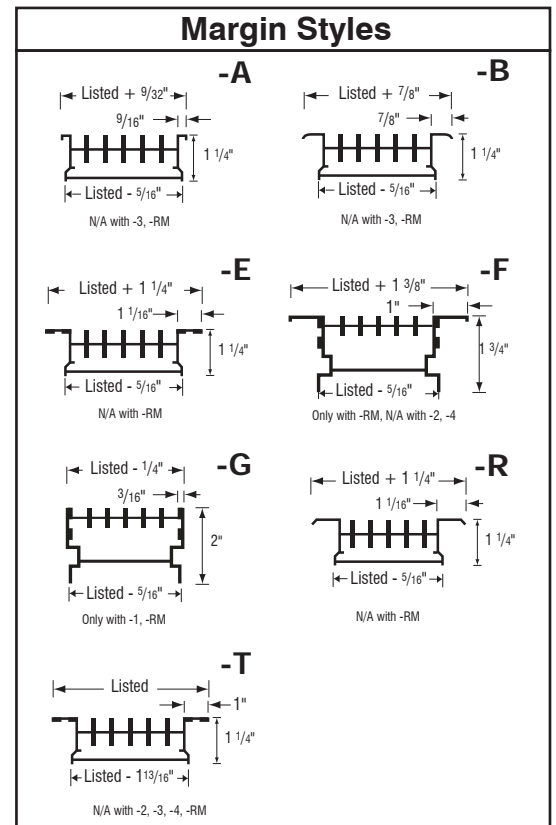
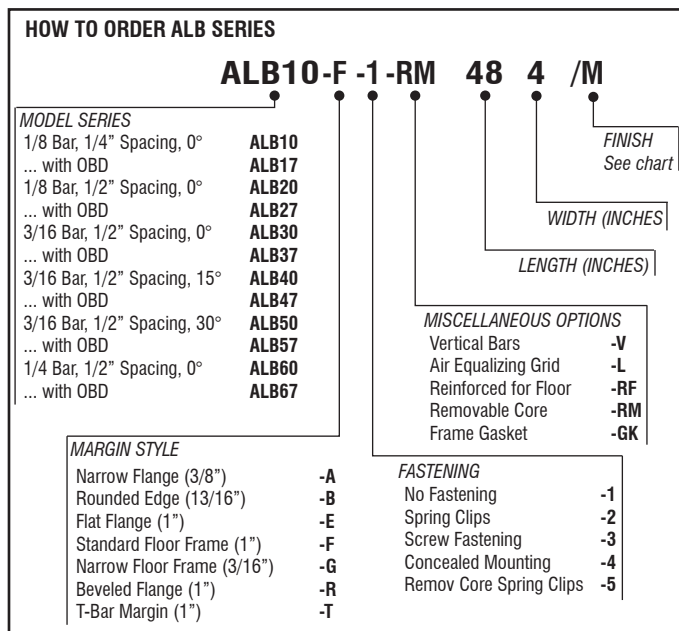
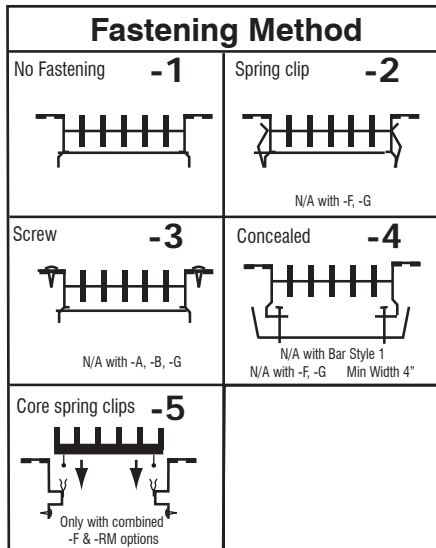
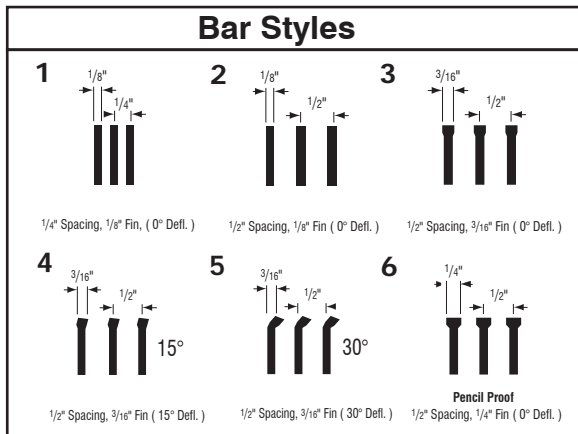


Mitered Corner

ARCHITECTURAL STYLES



ALB SERIES



- L** Air Equalizing Grid (Minimum 4" wide)
- RF** Reinforced Floor Application (Up to 8" wide for occasional traffic)
- RM** Removable Core Application Only w/ -F, -G
- GK** Frame Gasket

LISTED SIZES AVAILABLE

Min. (no OBD) LxW	Min. with OBD LxW	Max. LxW
6" x 1 1/2"	6" x 3"	60" x 16"

1/8 inch fractional increments in length
 1/2 inch fractional increments in width (no OBD)
 1 inch increments in width with OBD

Sizes longer than maximum will be furnished in multiple sections for field butting

All dimensions in inches.
 6" maximum width for constant traffic. 8" maximum width for occasional traffic.
 Series ALB products include a 1/32" tolerance for thermal expansion based on a +40°F temperature differential.
 For every +20°F differential above +40°F, reduce required listed length by 1/64" per 5 feet of length.

ENGINEERING PERFORMANCE DATA

ALB SERIES



NOTES:

- a. Table 1 based on 4 ft. grille length. For longer lengths, correct throw and NC per Table 2.
- b. When using continuous grille lengths with alternate active and inactive sections, a reduction in throw can be obtained by omitting the factors contained in table 2.
- c. Bar style 1: Increase Table 1 NC + 5 NC.
- d. Supply air temperature effect on horizontal throw is shown in table 3. Vertical down-throw at varying supply temperatures is shown in Table 4.
- e. When spreading the air path with horizontal deflection of 22° per side in grille lengths up to 4 ft.:
 - Multiply Table 1 Throw x .75
 - Increase Table 1 NC x 5 NC
 - Multiply Table 1 P_S x 1.20
 - Multiply Table 5 A_K x .90
- f. Terminal velocities (V_T) at the minimum and maximum Throw (T) values are rated at 125 FPM and 75 FPM respectively with corresponding room velocities (V_R) of 50 fpm and 35 FPM.

TABLE 2 CONTINUOUS GRILLE LENGTH FACTORS

Modify Table 1 by listed values for grille lengths above 4ft.			
Grille Length	Throw (T)		NC
	Sidewall Min.-Max.	Sill Min.-Max.	
4' - 6'	No Change		+ 0
7' - 20'	T x 1.10		+ 5
21' - 100'	T x 1.15		+ 10

TABLE 3 SUPPLY AIR TEMPERATURE FACTORS

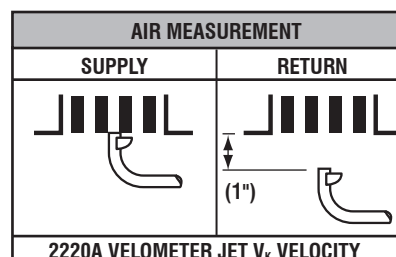
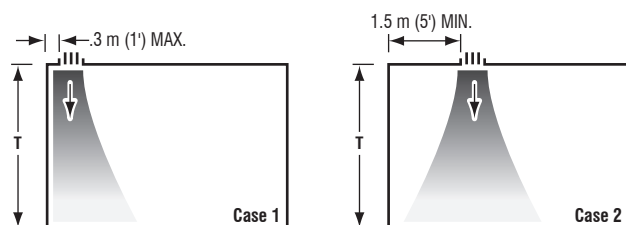
Multiply Throw in Table 1 (or factor in Table 2 if used) by listed value.			
	@-29°C ΔT	@-18°C ΔT	@-4°C ΔT
	Sidewall	@-20°F ΔT T x 1.10	@ 0°F ΔT T x 1.11
Sill			

TABLE 4 VERTICAL DOWN-THROW and Supply Air Temperature Supply Factors

Multiply Throw-Sidewall in Table 1 (or factor in Table 2 if used) by listed value.			
	@ -29°C ΔT	@ -18°F ΔT	@ -4°C ΔT
	@ -20°F ΔT	@ 0°F ΔT	@ +25°F ΔT
	Cooling	Ventilating	Heating
Case 1	T x 1.10	T x .90	T x .60
Case 2	T x .70	T x .60	T x .40

TABLE 5 SUPPLY GRILLES AREAS Per Ft. of Length

Listed Width in inches																	
A_N	1.5"	2"	2.5"	3"	4"	5"	6"	8"	10"	12"	14"	16"	18"	20"	24"	30"	36"
	.13	.17	.21	.25	.33	.42	.50	.67	.84	1.0	1.2	1.3	1.5	1.7	2.0	2.5	3.0
A_K	.04	.06	.09	.11	.16	.20	.25	.35	.45	.55	.68	.79	.90	1.0	1.3	1.6	2.1
A_K	.03	.05	.08	.09	.14	.17	.21	.30	.38	.47	.58	.67	.77	.85	1.1	1.4	1.8



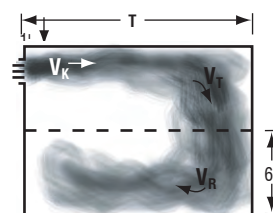
ENGINEERING PERFORMANCE DATA

ALB SERIES

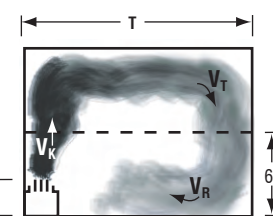


TABLE 1 SUPPLY AIR

CFM per Foot	Listed Width in Inches	Min. P _s in H ₂ O		Outlet Velocity (V _k) FPM		Throw (T) in Feet		Minimum Ceiling Height in Feet		NC			
		Bar Style		Bar Style		Sidewall	Sill	@-18°F ΔT	@-25°F ΔT				
		2 & 3 & 4 & 5	1 & 6	2 & 3 & 4 & 5	1 & 6	Min.-Max.	Min.-Max.						
20	1 1/2	.01	.01	500	575	6-9	1-2	8	9	<20			
30	1 1/2	.03	.04	750	865	7-10	2-3	9	10	25			
	2	.01	.01	475	545	6-9	1-2			20			
40	1 1/2	.05	.07	1000	1150	9-13	3-5	9	11	30			
	2	.02	.03	635	730	8-11	2-4			25			
	2 1/2	.01	.01	460	530	7-10	2-3			20			
50	1 1/2	.09	.12	1250	1440	11-16	4-9	9 1/2	11	30			
	2	.03	.04	790	910	10-14	3-7			25			
	2 1/2	.02	.03	575	660	9-13	2-6			20			
	3	<.01	.01	440	505	8-12	2-5			<20			
60	2	.05	.07	950	1090	12-18	5-11	9 1/2	12	30			
	2 1/2	.02	.03	690	795	11-16	4-9			25			
	3	.01	.01	530	610	10-14	3-7			20			
	4	<.01	.01	370	425	8-12	2-5			<20			
70	2	.06	.08	1100	1275	14-20	7-13	10	12	30			
	2 1/2	.03	.04	810	935	13-19	6-12			30			
	3	.02	.03	660	760	11-16	4-9			25			
	4	<.01	.01	435	500	10-14	3-7			<20			
80	2	.08	.10	1275	1450	16-23	9-16	10 1/2	12 1/2	30			
	2 1/2	.04	.05	920	1060	15-21	8-14			30			
	3	.03	.04	700	805	13-18	6-11			25			
	4	.01	.01	495	570	11-16	4-9			20			
90	2 1/2	.05	.07	1030	1185	17-24	10-17	11	13	30			
	3	.04	.05	785	905	15-21	8-14			30			
	4	.01	.02	550	635	13-18	6-11			25			
	5	<.01	.01	450	520	11-16	4-9			20			
	2 1/2	.06	.08	1150	1325	19-27	12-20			11	13	30	
3	.04	.05	875	1010	16-23	9-16	30						
4	.02	.03	620	715	14-20	7-13	25						
5	.01	.01	500	575	12-18	5-11	20						
120	3	.06	.08	1050	1210	19-28	11-20	11 1/2	13			30	
	4	.03	.04	745	855	17-24	9-16			30			
	5	.02	.03	600	680	15-22	7-14			25			
	6	<.01	.01	480	550	13-19	5-11			20			
	140	3	.08	.11	1220	1410	22-32			14-24	11 1/2	14	35
		4	.04	.05	870	1000	19-28			11-20			30
5		.02	.03	700	810	17-25	9-17	25					
6		.01	.01	560	645	15-22	7-14	20					
160	4	.05	.07	990	1140	22-32	13-23	12	15	35			
	5	.03	.04	800	925	19-29	10-20			30			
	6	.02	.03	640	735	18-26	9-17			25			
	8	.01	.01	460	530	15-22	6-13			20			
180	4	.07	.09	1110	1275	25-36	16-27	12	15	35			
	5	.04	.05	900	1035	22-33	13-24			30			
	6	.03	.04	725	835	20-30	11-21			25			
	8	.02	.03	520	600	17-25	8-16			20			
200	4	.08	.11	1240	1425	28-41	-	12	15	40			
	5	.05	.07	1000	1150	24-36	-			35			
	6	.04	.05	800	925	23-33	-			30			
	8	.02	.03	575	665	20-28	-			25			
250	5	.08	.11	1250	1440	30-46	-	13	15	40			
	6	.05	.07	1000	1150	27-39	-			35			
	8	.03	.04	720	830	25-35	-			30			
	10	.01	.01	550	635	21-32	-			25			
300	6	.07	.09	1200	1375	33-48	-	13	15	40			
	8	.04	.05	865	1000	29-42	-			35			
	10	.02	.03	665	765	25-39	-			30			
	12	.01	.01	545	630	23-33	-			25			
350	8	.05	.08	1020	1175	34-48	-	13	15	40			
	10	.03	.04	780	900	29-45	-			35			
	12	.02	.03	640	735	26-38	-			30			
400	8	.08	.11	1170	1350	40-55	-	14	16	45			
	10	.04	.05	890	1025	33-50	-			40			
	12	.03	.04	730	845	30-44	-			35			



SIDEWALL



SILL

DATA SHEET

Outlet Velocity (V _k) FPM										
500	600	700	800	900	1000	1200	1400	1600	1800	2000
Total Pressure (P _T) Inches H ₂ O										
.02	.02	.03	.04	.05	.06	.09	.12	.16	.20	.25

- SYMBOLS
- V_T Terminal Velocity in fpm
 - V_R Room Velocity in fpm
 - V_K Outlet Velocity in fpm
 - A_K Outlet area in Sq. Feet
 - A_N Neck Area in Sq. Ft.
 - P_S Static Pressure H₂O
 - NC Re 8db Room attenuation
 - T Throw in feet at X and Y
 - ΔT Temperature Differential

ENGINEERING PERFORMANCE DATA

ALB SERIES



TABLE 2 RETURN AIR - CFM Per Foot of Length

Listed Width in Inches	A _K Area	Bar Style	NC 20-25 Non-Ducted		NC 25-30 Ducted		NC 30-40 Ducted	
			-.02" P _S	-.03" P _S	-.08" P _S	-.10" P _S	-.15" P _S	-.20" P _S
			CFM	CFM	CFM	CFM	CFM	CFM
1 1/2	.13	3 4 1	20	25	40	45	55	65
	.12	5	15	20	35	40	45	55
2	.18	3 4 1	30	40	65	70	90	100
	.17	5	25	35	55	60	75	85
2 1/2	.23	3 4 1	45	50	85	95	115	135
	.22	5	35	45	70	80	100	115
3	.27	3 4 1	55	65	105	120	145	165
	.25	5	45	55	90	100	120	140
4	.34	3 4 1	75	90	150	165	205	235
	.33	5	60	75	125	140	170	195
5	.41	3 4 1	95	120	190	215	260	305
	.39	5	80	100	160	180	220	255
6	.46	3 4 1	120	145	240	265	325	375
	.44	5	100	120	200	220	270	315

Listed Width in Inches	A _K Area	Bar Style	NC 20-25 Non-Ducted		NC 25-30 Ducted		NC 30-40 Ducted	
			-.02" P _S	-.03" P _S	-.08" P _S	-.10" P _S	-.15" P _S	-.20" P _S
			CFM	CFM	CFM	CFM	CFM	CFM
8	.57	3 4 1	160	200	325	360	445	515
	.54	5	135	165	270	305	370	430
10	.68	3 4 1	210	255	415	465	570	655
	.64	5	175	215	350	390	475	550
12	.76	3 4 1	255	310	510	565	695	800
	.72	5	210	260	425	475	580	670
16	.93	3 4 1	350	430	700	785	960	1100
	.86	5	285	350	570	635	780	900
20	1.1	3 4 1	445	545	885	990	1220	1410
	1.0	5	365	445	730	815	1000	1160
24	1.25	3 4 1	540	660	1080	1210	1475	1710
	1.15	5	440	540	880	985	1200	1390
30	1.45	3 4 1	670	820	1335	1495	1825	2110
	1.32	5	550	670	1090	1225	1500	1735
36	1.65	3 4 1	820	1010	1645	1835	2250	2600
	1.5	5	670	820	1335	1490	1825	2110

SYMBOLS

V_T Terminal Velocity in fpm
 V_R Room Velocity in fpm
 V_K Outlet Velocity in fpm

A_K Outlet area in Sq. Feet
 P_T Total Pressure H₂O
 P_S Static Pressure H₂O

NC Re 8db Room attenuation
 T Throw in feet at X and Y
 ΔT Temperature Differential



HOW TO SPECIFY ARCHITECTURAL LINEAR BAR GRILLES AND REGISTERS

Supply Register

Supply and mounting of linear bar register with attached opposed blade damper and 45 degree mitered corners, series **ALB**. Constructed from extruded aluminum, manufactured by Airvector.

Return Grille

Supply and mounting of linear bar grille with 45 degree mitered corners, series **ALB**. Constructed from extruded aluminum, manufactured by Airvector.

Linear Flow Bar Diffuser ALF10/ALF20 Series

1.0" Slot width	1-Slot	CFM	30	45	60	75	91	107
		Ps	0.024	0.053	0.100	0.161	0.240	0.332
		NC	-	24	33	40	46	51
	2-Slot	CFM	51	82	111	142	173	204
		Ps	0.024	0.053	0.099	0.160	0.238	0.330
		NC	-	26	35	43	49	55
1.5" Slot width	1-Slot	CFM	37	52	67	83	99	115
		Ps	0.022	0.042	0.070	0.087	0.156	0.210
		NC	-	22	27	35	41	45
	2-Slot	CFM	68	93	118	114	170	196
		Ps	0.025	0.042	0.065	0.095	0.131	0.172
		NC	-	23	26	36	41	45
2.0" Slot width	1-Slot	CFM	39	59	79	100	121	142
		Ps	0.018	0.033	0.059	0.094	0.139	0.191
		NC	-	22	29	34	42	48
	2-Slot	CFM	60	100	140	181	222	263
		Ps	0.016	0.031	0.057	0.091	0.136	0.189
		NC	-	22	30	37	44	50
2.5" Slot width	1-Slot	CFM	46	71	96	121	146	172
		Ps	0.020	0.044	0.085	0.135	0.202	0.282
		NC	-	21	29	34	42	48
	2-Slot	CFM	77	122	167	212	257	303
		Ps	0.020	0.041	0.074	0.118	0.174	0.240
		NC	-	21	32	37	42	47
3 " Slot width	1-Slot	CFM	48	78	180	138	168	199
		Ps	0.018	0.045	0.088	0.151	0.233	0.333
		NC	-	22	25	34	40	45
	2-Slot	CFM	79	139	199	259	319	380
		Ps	0.018	0.045	0.081	0.151	0.233	0.333
		NC	-	21	29	37	43	48

SYMBOLS Ps Static Pressure in inches of water
 Throw Horizontal distances in feet to a terminal velocity of 50 FPM
 NC Noise Criteria based on 10 db room absorption

LineAirFlow Diffusers

Adjustable high-flow slider - ALF17/ALF27 Series

1.0" Slot width	1-Slot	CFM	30	45	60	76	92	111
		Ps	0.040	0.095	0.127	0.270	0.395	0.542
		Throw	5-9-15	9-13-18	12-15-21	14-17-24	15-18-26	16-20-28
		NC	-	21	31	37	44	49
	2-Slot	CFM	60	88	110	140	162	192
		Ps	0.041	0.084	0.142	0.216	0.305	0.412
		Throw	8-12-21	11-17-25	15-20-29	18-23-32	20-23-32	21-26-38
		NC	-	23	33	37	44	48
1.5" Slot width	1-Slot	CFM	35	50	66	82	97	116
		Ps	0.044	0.093	0.160	0.248	0.350	0.472
		Throw	7-11-16	10-14-19	13-16-22	14-17-24	15-19-27	16-21-29
		NC	-	21	30	38	43	48
	2-Slot	CFM	70	98	120	150	170	202
		Ps	0.043	0.082	0.130	0.192	0.265	0.355
		Throw	10-15-23	14-19-27	17-21-30	19-23-33	21-25-36	22-27-38
		NC	-	21	30	38	41	45
2.0" Slot width	1-Slot	CFM	35	55	76	97	112	141
		Ps	0.027	0.07	0.133	0.217	0.320	0.440
		Throw	7-10-16	11-14-20	14-17-24	16-19-27	17-21-29	18-23-32
		NC	-	17	27	34	41	45
	2-Slot	CFM	70	107	141	179	212	251
		Ps	0.027	0.063	0.113	0.178	0.258	0.352
		Throw	8-13-23	13-20-28	17-23-32	21-25-36	23-28-39	24-30-43
		NC	-	17	25	35	40	45
2.5" Slot width	1-Slot	CFM	45	69	94	118	143	170
		Ps	0.028	0.067	0.124	0.198	0.291	0.400
		Throw	7-10-18	11-16-22	15-18-26	17-21-29	19-23-32	20-25-35
		NC	-	20	30	37	43	48
	2-Slot	CFM	90	135	177	223	265	311
		Ps	0.028	0.061	0.109	0.170	0.245	0.330
		Throw	10-15-26	15-22-31	19-25-36	23-28-40	25-31-44	27-34-47
		NC	-	22	31	38	42	48
3 " Slot width	1-Slot	CFM	50	79	109	149	169	201
		Ps	0.030	0.078	0.148	0.240	0.360	0.495
		Throw	7-11-19	12-18-24	16-20-28	19-22-32	20-25-35	22-27-38
		NC	-	-	25	34	40	45
	2-Slot	CFM	100	152	218	281	341	401
		Ps	0.03	0.078	0.148	0.24	0.36	0.495
		Throw	9-16-27	17-24-34	23-28-40	26-32-45	28-35-49	31-38-54
		NC	-	19	28	37	43	48

SYMBOLS Ps Static Pressure in inches of water
 Throw Horizontal distances in feet to a terminal velocity of 50 FPM
 NC Noise Criteria based on 10 db room absorption

LineAirFlow Bar Diffusers Jet-flow baffles - ALF18/ALF28 Series

TABLE 1 - 48" One Slot Diffuser Width 8" Inlet (Adjustable throw)

1.0" Slot width	1-Slot	CFM	30	45	60	76	92	111
		Ps	0.040	0.095	0.127	0.270	0.395	0.542
		Throw	5-9-15	9-13-18	12-15-21	14-17-24	15-18-26	16-20-28
		NC	-	21	31	37	44	49
1.5" Slot width	1-Slot	CFM	35	50	66	82		116
		Ps	0.044	0.093	0.160	0.248	0.350	0.472
		Throw	7-11-16	10-14-19	13-16-22	14-17-24	15-19-27	16-21-29
		NC	-	21	30	38	43	48
2.0" Slot width	1-Slot	CFM	35	55	76	97	112	141
		Ps	0.027	0.07	0.133	0.217	0.320	0.440
		Throw	7-10-16	11-14-20	14-17-24	16-19-27	17-21-29	18-23-32
		NC	-	17	27	34	41	45
2.5" Slot width	1-Slot	CFM	45	69	94	118	143	170
		Ps	0.028	0.067	0.124	0.198	0.291	0.400
		Throw	7-10-18	11-16-22	15-18-26	17-21-29	19-23-32	20-25-35
		NC	-	20	30	37	43	48
3 " Slot width	1-Slot	CFM	50	79	109	149	169	201
		Ps	0.030	0.078	0.148	0.240	0.360	0.495
		Throw	7-11-19	12-18-24	16-20-28	19-22-32	20-25-35	22-27-38
		NC	-	-	25	34	40	45

SYMBOLS Ps Static Pressure in inches of water
 Throw Horizontal distances in feet to a terminal velocity of 50 FPM
 NC Noise Criteria based on 10 db room absorption

LENGTH MULTIPLIERS AND ADJUSTMENTS

For other lengths than 48", divide above CFM by 4 to get CFM/foot, then use the multipliers and adjustments below.

Diffuser Length	2'	4'	6'	8'	10'
Throw Multiplier	0.9	1	1.1	1.2	1.3
NC Adjustment	-2	0	+2	+3	+4

SLOT DIFFUSERS

ALS SERIES SLOT DIFFUSER

For Ceiling, Sidewall and Sill Installation

Series **ALS** Architectural Linear Slot Diffusers are designed for installation in the ceiling, sidewall or sill and are recommended for supplying heated, ventilated or cooled air and for returning or exhausting room air. Air pattern directional changes through 180° are effected by the integral "Uniflex" combination pattern and volume controller, permitting pattern adjustment to meet changing requirements. Their reliable performance assures confident use of cooling temperature differentials up to 25°F at predicted low air motion 35 FPM in the zone of occupancy. Series ALS Supply Diffusers perform efficiently with air loadings of 1 to 3 CFM per square feet of floor area or 6 to 18 air changes per hour (based on 10ft. ceiling height) at a sound level range of NC 25 to 35.

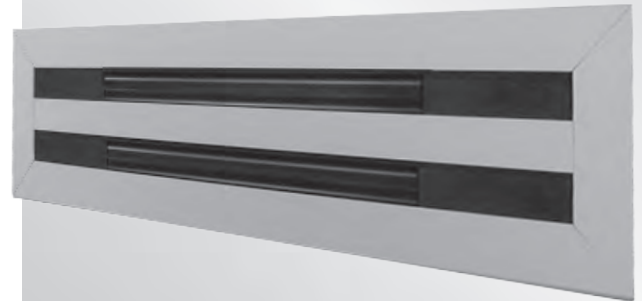
When installed in the ceiling, Series ALS Diffusers provide a horizontal air path that is adjustable through 180° in each slot opening. One to ten slot ALS Diffusers can be adjusted to provide one-way or two-way air patterns by directing the controller as required to either side.

Vertical downward air pattern can be adjusted from all slots. A combination horizontal pattern and vertical down pattern can be effected from a two (or more) slot diffuser.

Series ALS diffusers are fabricated of high-quality aluminum extrusions. The pattern controller is coated dull black to accent the slot opening. Components are mechanically interlocked together for a blemish-free appearance. Keyways and splice plates facilitate sections over 72" to form continuous lengths. Ninety degree mitered corner sections are furnished in one piece.

Concealed mounting brackets fit in a hemmed duct collar to positively hold the diffuser in ceiling and sidewall installations. Series ALS diffusers used for return or exhaust air are identical to supply sections except the pattern controller is removed to increase air capacity.

**The Airvector® exclusive UNIFLEX
pattern and volume controller**



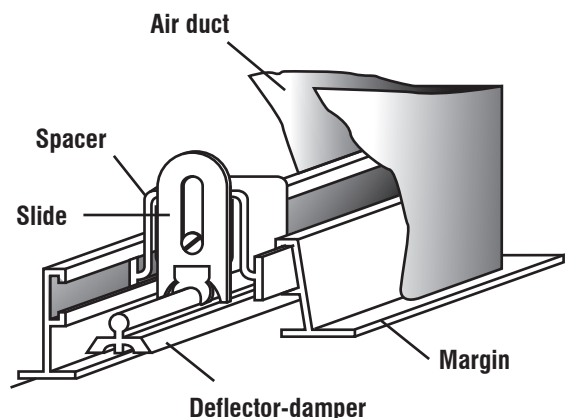
ALS37

FEATURES

- THREE SLOT SIZES, 1/2", 3/4" and 1".
- ONE TO EIGHT slots wide for air volume of 10-350 CFM per foot.
- EXTRUDED ALUMINUM construction: mechanical assembly.
- White powder paint finish-standard.
- OVERLAPPING OR T-BAR MARGINS.

ACCESSORIES

- Mitered Corner Sections
- AVAILABLE BUTTS in continuous lengths with key-way splices. Factory cut or field cut lengths for precise installation.
- 180° "UNIFLEX" ADJUSTABLE PATTERN AND VOLUME CONTROLLER provides positive positioning, constant static pressure, constant outlet area.



ARCHITECTURAL STYLES

ALS SERIES SLOT DIFFUSER



LISTED SIZES AVAILABLE
Any fractional inch increment of length 12" to 72"
One to ten slots
Lengths longer than 72" will be furnished in multiple sections for field butting.
Custom Paint - Lengths over 60" will be furnished in multiple sections

STYLE DETAILS
<p>Return</p> <p>MARGIN ONLY</p>
<p>Supply</p> <p>MARGIN, DAMPER AND PATTERN CONTROLLER</p>

HOW TO ORDER ALS SERIES

ALS37 -E -4 -GK 48 2 /W

MODEL SERIES

1" Slot Diffuser	ALS17
1" Slot Return	ALS10
1/2" Slot Diffuser	ALS27
1/2" Slot Return	ALS20
3/4" Slot Diffuser	ALS37
3/4" Slot Return	ALS30

MARGIN STYLE

Sidewall -E
T-Bar Lay-In -T

FASTENING

No Fastening -1
Screw Fastening -3
Concealed Mounting -4

FINISH (OPTIONAL)
Standard is White (W)
See chart for more

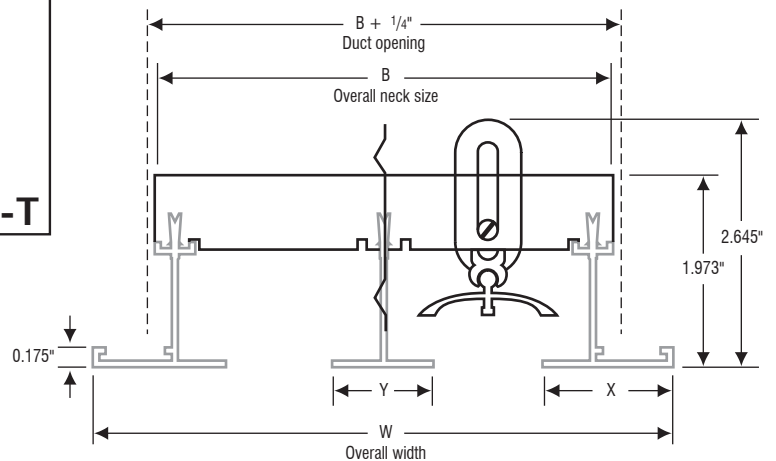
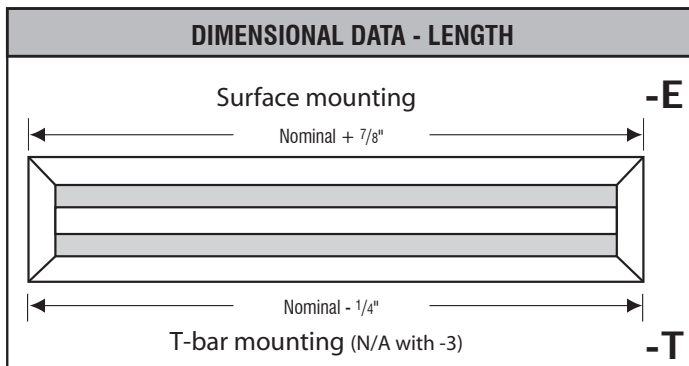
NUMBER OF SLOTS
1-8

LENGTH (INCHES)
48

Frame Gasket -GK

Series ALS products include a 1/32" tolerance for thermal expansion based on +40 degree F temperature differential. For every +20 degree F differential above +40 degree F, reduce required listed length by 1/64" per 5 feet of length.

FASTENING METHOD		
No Fastening -1	Screw -3	Concealed -4
	N/A with -T	



1/2" SLOT		3/4" SLOT		1" SLOT	
X	Y	X	Y	X	Y
1 1/8"	11/16"	1 1/8"	11/16"	1 1/4"	1"

1/2" SLOT

SLOTS	B	W
1	1 9/16"	2 23/32"
2	2 3/4"	3 29/32"
3	3 15/16"	5 3/32"
4	5 1/8"	6 9/32"
5	6 5/16"	7 15/32"
6	7 1/2"	8 21/32"
7	8 11/16"	9 27/32"
8	9 7/8"	11 1/32"

3/4" SLOT

SLOTS	B	W
1	1 13/16"	2 31/32"
2	3 1/4"	4 13/32"
3	4 11/16"	5 27/32"
4	6 1/8"	7 9/32"
5	7 9/16"	8 23/32"
6	9"	10 5/32"
7	10 7/16"	11 19/32"
8	11 7/8"	13 1/32"

1" SLOT

SLOTS	B	W
1	2 3/8"	3 17/32"
2	4 3/8"	5 17/32"
3	6 3/8"	7 17/32"
4	8 3/8"	9 17/32"
5	10 3/8"	11 17/32"
6	12 3/8"	13 17/32"
7	14 3/8"	15 17/32"
8	16 3/8"	17 17/32"

DATA SHEET

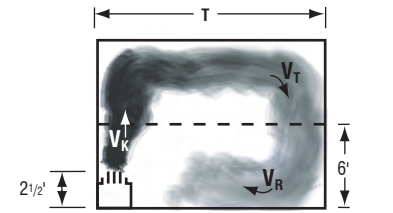
ENGINEERING PERFORMANCE DATA

ALS17 1" SLOT SUPPLY DIFFUSER

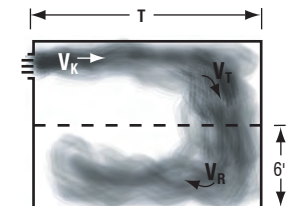


TABLE 1 SUPPLY AIR

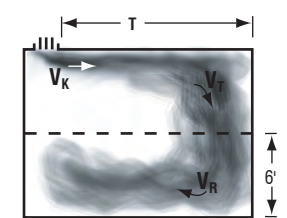
CFM per Foot in Direction of T	No. of Slots	Min. P _s In. H ₂ O	Outlet Velocity (V _k) FPM	Throw (T) in Feet			Minimum Ceiling Height in Feet		NC
				Ceiling	Sidewall	Sill	@ -18F ΔT	@ -25F ΔT	
				Min.-Max.	Min.-Max.	Min.-Max.			
20	1	.02	500	6-8	4-7	1-2	8	9	20
30	1	.03	750	9-13	7-10	2-3	9	10	20
	2	.02	500	7-9	5-7	1-2			20
40	1	.06	1000	10-14	9-14	4-6	9	11	25
	2	.03	670	8-10	6-9	2-3			20
50	1	.09	1250	12-15	10-14	3-5	9 1/2	11	31
	2	.04	835	10-14	8-12	3-4			20
	3	.02	555	9-11	7-10	2-3			20
60	2	.06	1000	15-18	9-13	4-6	9 1/2	12	30
	3	.03	665	10-13	7-11	2-4			20
	4	.02	500	8-11	6-9	2-3			20
70	2	.09	1165	13-17	11-15	5-8	10	12	30
	3	.04	780	11-16	9-14	4-6			25
	4	.02	585	10-14	7-11	3-4			20
80	2	.11	1335	15-19	14-17	6-10	10 1/2	12 1/2	35
	3	.05	890	12-17	10-14	4-7			25
	4	.03	665	10-14	8-12	3-5			20
	5	.02	533	9-13	7-11	2-4			20
90	3	.06	1000	14-19	11-17	5-10	11	13	30
	4	.04	750	13-18	11-15	4-8			25
	5	.02	600	12-16	10-14	3-7			20
	6	.02	500	11-15	9-13	3-6			20
100	3	.08	1110	16-21	14-20	7-12	11	13	30
	4	.04	835	15-20	13-18	6-11			25
	5	.03	665	14-18	12-16	5-9			20
	6	.02	555	13-17	11-15	4-8			20
120	3	.11	1335	18-25	16-22	8-13	11 1/2	13	35
	4	.06	1000	17-24	15-20	7-13			30
	5	.04	800	16-23	14-21	6-12			25
	6	.03	665	15-21	13-19	5-11			20
140	4	.09	1165	18-25	16-21	8-15	11 1/2	14	30
	5	.05	935	18-26	16-22	8-14			30
	6	.04	780	17-25	15-22	7-14			25
	7	.03	665	16-23	14-20	6-12			20
160	4	.11	1335	19-27	17-24	10-16	12	15	35
	5	.07	1065	18-26	16-23	8-15			30
	6	.05	890	17-25	15-22	7-14			25
	7	.04	760	16-23	14-20	6-12			25
180	5	.09	1200	20-30	18-27	10-19	12	15	35
	6	.06	1000	19-28	17-25	9-17			30
	7	.05	850	18-26	16-23	8-15			25
	8	.04	750	16-24	14-21	6-13			20
200	5	.11	1335	23-33	20-30	12-21	12	5	35
	6	.08	1110	21-32	19-29	10-20			30
	7	.06	950	20-31	18-27	9-18			30
	8	.04	835	18-27	16-24	8-16			25
250	6	.12	1390	24-35	21-31	-	13	15	35
	7	.09	1190	23-34	20-30	-			35
	8	.07	1040	21-32	19-28	-			30
	9	.05	925	20-31	18-27	-			25
300	7	.13	1430	25-40	23-35	-	13	16	35
	8	.10	1250	24-36	22-32	-			35
	9	.08	1110	23-34	20-30	-			30
	10	.06	1000	22-32	19-28	-			30
350	8	.13	1460	27-47	24-43	-	14	16	40
	9	.11	1300	26-45	23-41	-			35
	10	.09	1165	25-42	22-39	-			30



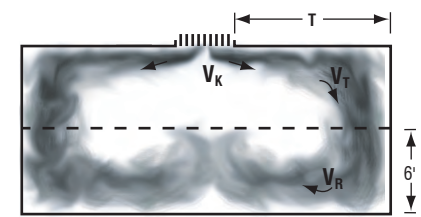
SILL



SIDEWALL



CEILING ONE WAY



CEILING TWO WAY

DATA SHEET

9 and 10 slots not available

ENGINEERING PERFORMANCE DATA

ALS17 1" SLOT SUPPLY DIFFUSER



NOTES:

- Table 1 based on 4 ft. diffuser length. For longer lengths, correct throw and NC per Table 2.
- For 2-way ceiling throw, proportion (CFM) and number of slots in each direction of T and select from 1-way data, Table 1.
- When using continuous diffuser lengths with alternating active and inactive sections, a reduction in throw can be obtained by omitting the factors contained in Table 2.
- P_s constant for horizontal 1-way, 2-way and vertical pattern adjustment.
- Supply air temperature effect on horizontal throw is shown in Table 3. Vertical throw at varying supply air temperatures is shown in Table 4.
- Terminal velocities (V_T) at the minimum and maximum Throw (T) positions are rated at 150 FPM and 100 FPM respectively with corresponding room velocities (V_R) of 50 FPM and 35 FPM.

TABLE 2 CONTINUOUS DIFFUSER LENGTH FACTORS

Modify Table 1 by factors for diffuser lengths above 4ft.				
Diffuser Length	Throw (T)			NC
	Ceiling Min.-Max.	Sidewall Min.-Max.	Sill Min.-Max.	
4' - 6'	No Change			+ 0
7' - 20'	T x 1.10			+ 5
21' - 100'	T x 1.15			+ 10

TABLE 3 SUPPLY AIR TEMPERATURE FACTORS

Multiply Throw in Table 1 (or factor in Table 2 if used) by listed value.			
Ceiling Sidewall Sill	@ - 11°C ΔT	@ 0°C ΔT	@ + 14°C ΔT
	@ - 20F ΔT	@ 0F ΔT	@ + 25F ΔT
	T x 1.0	T x 1.1	T x 1.2

TABLE 4 VERTICAL DOWN-THROW and Supply Temperature Factors

Multiply Throw-Sidewall in Table 1 (or factor in Table 2 if used) by listed value.			
	@ - 11°C ΔT	@ 0°C ΔT	@ + 14°C ΔT
	@ - 20F ΔT	@ 0F ΔT	@ + 25F ΔT
	Cooling	Ventilating	Heating
Case 1	T x 1.0	T x .90	T x .60
Case 2	T x .70	T x .60	T x .40

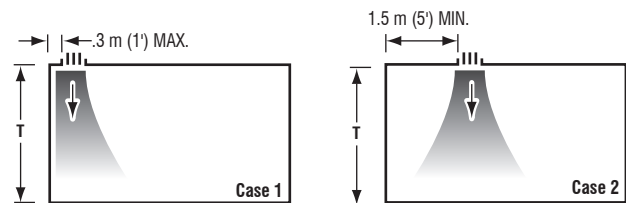
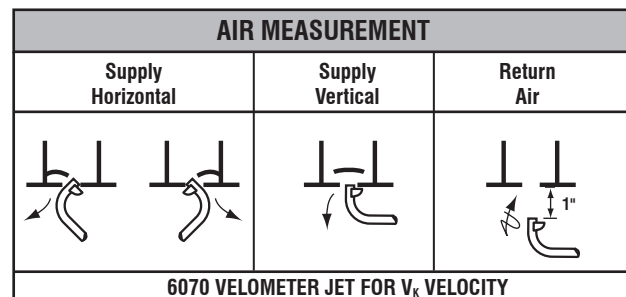


TABLE 5 SUPPLY DIFFUSERS AREAS Per Ft. of Length

	No. of Slots							
	1	2	3	4	5	6	7	8
A_N Area	.04	.06	.09	.12	.15	.18	.21	.24
	.17	.33	.50	.67	.83	1.00	1.17	1.33



A_K constant for horizontal 1-way, 2-way and vertical pattern.

$$CFM = A_K \times \text{length in feet} \times V_K$$

ENGINEERING PERFORMANCE DATA

ALS10 1" SLOT RETURN



TABLE 1 RETURN AIR CFM PER FOOT OF LENGTH

No. of Slots	A _K Area	NC 20-25 Application Non-Ducted		NC 30 Application Ducted		NC 35-40 Application Ducted	
		- .02" P _S	- .03" P _S	- .08" P _S	- .10" P _S	- .15" P _S	- .20" P _S
		CFM	CFM	CFM	CFM	CFM	CFM
1	.06	35	43	70	80	95	110
2	.11	70	85	140	155	190	220
3	.17	105	130	210	235	285	330
4	.23	140	170	280	310	380	440
5	.28	175	215	350	390	475	550
6	.33	210	255	420	465	570	660
7	.39	245	300	490	545	665	770
8	.44	280	340	560	620	760	880

Capacity based on diffuser without pattern controller. When pattern controller is used CFM capacities are reduced by 65% at listed P_S, NC and A_K.

ENGINEERING PERFORMANCE DATA

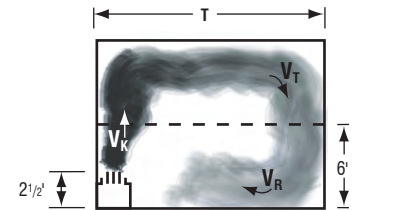
ALS27 1/2" SUPPLY SLOT DIFFUSER



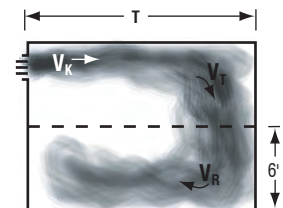
TABLE 1 SUPPLY AIR

CFM per Foot in Direction of T	No. of Slots	Min. P _s in. H ₂ O	Outlet Velocity (V _k) FPM	Throw (T) in Feet			Minimum Ceiling Height in Feet		NC
				Ceiling	Sidewall	Sill	@ -18F ΔT	@ -25F ΔT	
				Min.-Max.	Min.-Max.	Min.-Max.			
10	1	.02	500	5-7	3-5	1-2	7 1/2	9	<20
		<.01	335	4-6	2-4	1-2			<20
20	1	.08	1000	10-13	8-11	1-3	8	9	20
	2	.02	670	8-11	6-9	2-3			<20
	3	.01	400	6-9	4-7	1-2			<20
30	1	.18	1500	11-16	10-14	4-6	9	10	25
	2	.05	1000	10-14	8-12	3-4			20
	3	.02	600	8-11	6-9	2-3			<20
	4	.01	430	7-9	5-7	1-2			<20
40	2	.08	1330	13-17	11-15	4-6	9	11	25
	3	.04	800	10-14	8-12	3-5			20
	4	.02	570	9-12	7-10	2-3			20
50	5	.01	445	8-11	6-9	2-3	9 1/2	11	<20
	3	.06	1000	11-15	9-13	4-6			25
	4	.03	710	10-14	8-12	3-4			20
	5	.02	560	9-13	7-11	2-4			20
60	6	.01	500	8-12	7-10	1-3	9 1/2	12	<20
	3	.08	1200	13-17	11-15	5-8			25
	4	.05	855	12-16	10-14	4-7			25
70	5	.03	670	11-15	9-13	3-6	10	12	20
	6	.02	600	10-14	8-12	3-5			20
	7	.01	500	9-13	7-11	2-4			20
	4	.12	1400	15-20	13-18	6-11			25
80	5	.06	1000	13-18	11-16	5-9	10 1/2	12 1/2	25
	6	.04	780	12-16	10-14	4-7			25
	7	.03	700	11-15	9-13	3-6			20
	8	.02	580	10-15	8-13	2-5			20
90	4	.08	1140	14-20	12-18	6-11	11	13	25
	5	.05	890	13-19	11-17	5-10			25
	6	.04	800	13-18	11-16	5-9			25
	7	.03	670	13-17	11-15	4-8			20
100	8	.02	570	12-16	10-14	3-7	11	13	20
	4	.10	1280	17-24	15-21	8-14			30
	5	.07	1000	16-22	14-20	7-13			25
	6	.05	900	16-21	14-19	7-12			25
120	7	.04	750	15-20	13-18	6-11	11 1/2	13	25
	8	.03	640	14-18	12-16	5-9			20
	9	.02	600	13-17	11-15	4-8			20
	5	.09	1120	18-25	16-22	9-15			25
140	6	.06	1000	17-24	15-21	8-14	11 1/2	14	25
	7	.05	830	16-23	14-20	7-13			25
	8	.03	710	14-20	12-18	6-11			20
	9	.03	670	13-19	11-17	5-10			20
160	10	.02	590	12-18	10-16	5-10	12	15	<20
	6	.09	1200	19-27	17-24	10-16			30
	7	.07	1000	18-26	16-23	8-15			25
	8	.05	860	17-25	15-22	7-14			25
180	9	.04	800	16-24	14-21	6-13	12	15	20
	10	.03	705	15-22	13-19	5-11			20
	7	.10	1170	20-30	18-27	10-19			25
	8	.06	1000	19-28	17-25	9-17			25
200	9	.07	1070	20-30	18-27	9-18	12	15	25
	10	.05	940	19-28	17-25	8-17			20
	8	.08	1280	24-35	21-31	12-22			30
180	9	.07	1200	23-34	20-30	11-21	12	15	25
	10	.05	1060	22-32	19-29	10-20			25
	9	.10	1335	25-39	22-35	-			30
200	10	.08	1175	24-37	21-33	-	12	15	25

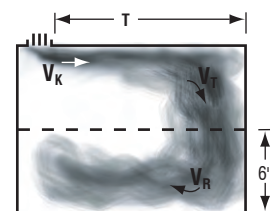
9 and 10 slots not available



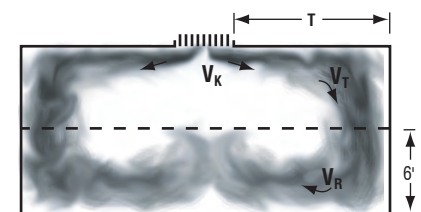
SILL



SIDEWALL



CEILING ONE WAY



CEILING TWO WAY

Outlet Velocity (V _k) FPM										
500	600	700	800	900	1000	1200	1400	1600	1800	2000
Total Pressure (P _T) Inches H ₂ O										
.02	.02	.03	.04	.05	.06	.09	.12	.16	.20	.25

- SYMBOLS**
- V_T Terminal Velocity in FPM
 - V_R Room Velocity in FPM
 - V_K Outlet Velocity in FPM
 - A_K Outlet area in Sq. Feet
 - A_N Neck Area in Sq. Ft.
 - P_S Static Pressure H₂O
 - NC Re 8db Room attenuation
 - T Throw in feet at X and Y
 - ΔT Temperature Differential

DATA SHEET

ENGINEERING PERFORMANCE DATA

ALS27 1/2" SLOT SUPPLY DIFFUSER



NOTES:

- a. Table 1 based on 4 ft. diffuser length. For longer lengths, correct throw and NC per Table 2.
- b. For 2-way ceiling throw, proportion (CFM) and number of slots in each direction of T and select from 1-way data, Table 1.
- c. When using continuous diffuser lengths with alternating active and inactive sections, a reduction in throw can be obtained by omitting the factors contained in Table 2.
- d. P_s constant for horizontal 1-way, 2-way and vertical pattern adjustment.
- e. Supply air temperature effect on horizontal throw is shown in Table 3. Vertical throw at varying supply air temperatures is shown in Table 4.
- f. Terminal velocities (V_T) at the minimum and maximum Throw (T) positions are rated at 150 FPM and 100 FPM respectively with corresponding room velocities (V_R) of 50 fpm and 35 FPM.

TABLE 2 CONTINUOUS DIFFUSER LENGTH FACTORS

Modify Table 1 by factors for diffuser lengths above 4ft.				
Diffuser Length	Throw (T)			NC
	Ceiling Min.-Max.	Sidewall Min.-Max.	Sill Min.-Max.	
4' - 6'	No Change			+ 0
7' - 20'	T x 1.10			+ 5
21' - 100'	T x 1.15			+ 10

TABLE 3 SUPPLY AIR TEMPERATURE FACTORS

Multiply Throw in Table 1 (or factor in Table 2 if used) by listed value.			
Ceiling Sidewall Sill	@ - 11°C ΔT	@ 0°C ΔT	@ +14°C ΔT
	@ - 20F ΔT	@ 0F ΔT	@ +25F ΔT
	T x 1.0	T x 1.1	T x 1.2

TABLE 4 VERTICAL DOWN-THROW and Supply Temperature Factors

Multiply Throw-Sidewall in Table 1 (or factor in Table 2 if used) by listed value.			
	@ - 11°C ΔT	@ 0°C ΔT	@ +14°C ΔT
	@ - 20F ΔT	@ 0F ΔT	@ +25F ΔT
	Cooling	Ventilating	Heating
Case 1	T x 1.0	T x .90	T x .60
Case 2	T x .70	T x .60	T x .40

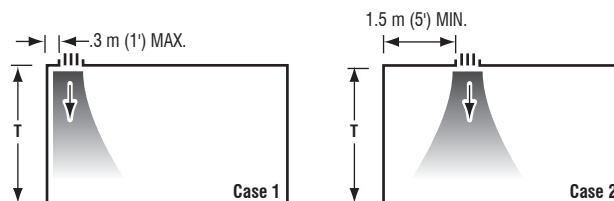
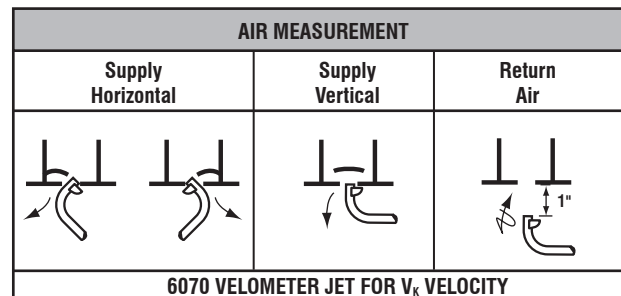


TABLE 5 SUPPLY DIFFUSERS AREAS Per Ft. of Length

	No. of Slots							
	1	2	3	4	5	6	7	8
A_N Area	.02	.03	.05	.07	.09	.10	.12	.14
A_K Area	.08	.17	.25	.33	.42	.50	.58	.67

A_K constant for horizontal 1-way, 2-way and vertical pattern.

$$CFM = A_K \times \text{length in feet} \times V_K$$



ENGINEERING PERFORMANCE DATA

ALS20 1/2" SLOT RETURN



TABLE 1 RETURN AIR CFM Per Foot of Length

No. of Slots	A _K Area	NC 20-25		NC 30		NC 35-40	
		Application Non-Ducted		Application Ducted		Application Ducted	
		- .02" P _s CFM	- .03" P _s CFM	- .08" P _s CFM	- .10" P _s CFM	- .15" P _s CFM	- .20" P _s CFM
1	.03	15	20	30	35	40	45
2	.06	35	45	70	80	95	110
3	.08	55	70	110	125	150	175
4	.11	70	85	140	155	190	220
5	.14	90	110	180	200	245	285
6	.16	110	135	220	245	300	345
7	.20	130	160	260	290	355	410
8	.22	140	170	280	310	385	440

Capacity based on diffuser without pattern controller. When pattern controller is used CFM capacities are reduced by 65% at listed P_s, NC and A_K.

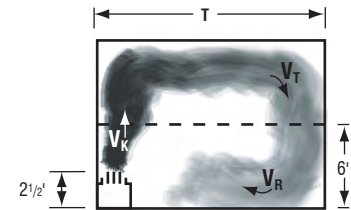
ENGINEERING PERFORMANCE DATA

ALS37 3/4" SUPPLY SLOT DIFFUSER

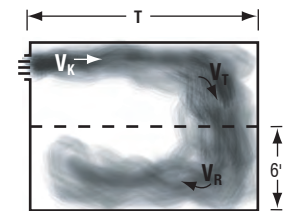


TABLE 1 SUPPLY AIR

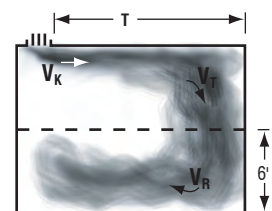
CFM per Foot in Direction of T	No. of Slots	Min. P _s in. H ₂ O	Outlet Velocity (V _k) FPM	Throw (T) in Feet			Minimum Ceiling Height in Feet		NC
				Ceiling	Sidewall	Sill	@ -18F ΔT	@ -25F ΔT	
				Min.-Max.	Min.-Max.	Min.-Max.			
10	1	.01	335	4-6	2-4	1-2	7 1/2	9	<20
20	2	.04	670	8-11	6-9	2-3	8	9	20
			400	6-9	4-7	1-2			<20
30	1	.09	1000	10-14	8-12	3-4	9	10	25
	2	.02	600	8-11	6-9	2-3			20
	3	<.01	430	7-9	5-7	1-2			<20
40	1	.16	1340	13-7	11-15	4-6	9	11	30
	2	.04	800	10-14	8-12	3-4			25
	3	.02	575	9-12	7-10	2-3			20
	4	.01	445	8-11	6-9	2-3			<20
50	2	.06	1000	11-15	9-13	4-6	9 1/2	11	25
	3	.03	715	10-14	8-12	3-4			20
	4	.02	555	9-13	7-11	2-3			<20
	5	<.01	415	7-12	6-10	2-3			<20
60	2	.09	1200	13-17	11-15	5-8	9 1/2	12	30
	3	.04	860	12-16	10-14	4-7			25
	4	.02	665	11-15	9-13	3-6			20
	5	.01	500	9-13	7-11	3-4			<20
	6	.01	500	9-13	7-11	3-4			<20
70	2	.13	1400	15-20	13-18	6-11	10	12	30
	3	.06	1000	13-18	11-16	5-9			25
	4	.03	775	12-16	10-14	4-7			20
	5	.02	585	10-15	8-13	3-5			<20
	6	.01	500	9-14	7-12	2-5			<20
	7	.01	500	9-14	7-12	2-5			<20
80	3	.07	1140	14-20	12-18	6-11	10 1/2	12 1/2	30
	4	.04	885	13-19	11-17	5-10			25
	5	.03	665	13-17	11-15	4-8			20
	6	.02	575	12-16	10-14	3-7			<20
	7	<.01	500	11-15	9-13	3-6			<20
	8	.01	500	11-15	9-13	3-6			<20
	9	.01	500	11-15	9-13	3-6			<20
90	3	.09	1290	17-24	15-21	8-14	11	13	30
	4	.05	1000	16-22	14-20	7-13			25
	5	.03	750	15-20	13-18	6-11			20
	6	.02	645	14-18	12-16	5-9			<20
	7	.01	560	13-17	11-15	4-8			<20
	8	.01	560	13-17	11-15	4-8			<20
	9	.01	560	13-17	11-15	4-8			<20
100	3	.13	1430	19-26	17-23	10-16	11	13	30
	4	.06	1110	18-25	16-22	9-15			25
	5	.04	830	16-23	14-20	7-13			20
	6	.03	715	14-20	12-18	6-11			20
	7	.02	630	13-19	11-17	5-10			<20
	8	.02	630	13-19	11-17	5-10			<20
	9	.02	630	13-19	11-17	5-10			<20
120	4	.09	1330	19-27	17-24	10-16	11 1/2	13	35
	5	.06	1000	18-26	16-23	8-15			30
	6	.04	860	17-25	15-22	7-14			25
	7	.03	750	16-23	14-20	6-12			20
	8	.02	630	15-20	13-18	5-10			<20
	9	.02	630	15-20	13-18	5-10			<20
	10	.02	630	15-20	13-18	5-10			<20
	11	.02	630	15-20	13-18	5-10			<20
140	5	.08	1170	20-30	18-27	10-19	11 1/2	14	30
	6	.06	1000	19-28	17-25	9-17			25
	7	.04	875	18-26	16-23	8-15			20
	8	.03	740	16-24	14-21	6-13			20
	9	.02	665	15-21	13-19	5-11			<20
	10	.02	665	15-21	13-19	5-11			<20
	11	.02	665	15-21	13-19	5-11			<20
	12	.02	665	15-21	13-19	5-11			<20
	13	.02	665	15-21	13-19	5-11			<20
160	6	.07	1150	21-32	19-29	10-20	12	15	25
	7	.05	1000	20-30	18-27	9-18			20
	8	.04	840	18-27	16-24	8-16			20
	9	.03	760	17-26	15-23	6-14			<20
	10	.02	695	16-25	14-22	5-13			<20
	11	.02	695	16-25	14-22	5-13			<20
	12	.02	695	16-25	14-22	5-13			<20
	13	.02	695	16-25	14-22	5-13			<20
	14	.02	695	16-25	14-22	5-13			<20
	15	.02	695	16-25	14-22	5-13			<20
180	6	.09	1290	24-35	21-31	12-22	12	15	30
	7	.07	1130	23-34	20-30	11-21			25
	8	.05	950	20-31	18-28	9-19			20
	9	.04	860	19-30	17-27	8-18			20
	10	.03	780	18-29	16-26	7-17			<20
	11	.03	780	18-29	16-26	7-17			<20
	12	.03	780	18-29	16-26	7-17			<20
	13	.03	780	18-29	16-26	7-17			<20
	14	.03	780	18-29	16-26	7-17			<20
	15	.03	780	18-29	16-26	7-17			<20
200	6	.11	1440	26-40	23-36	-	12	15	30
	7	.08	1250	25-38	22-34	-			25
	8	.06	1110	24-36	21-32	-			20
	9	.05	955	22-33	20-30	-			20
	10	.04	870	21-31	19-28	-			<20
	11	.04	870	21-31	19-28	-			<20
	12	.04	870	21-31	19-28	-			<20
	13	.04	870	21-31	19-28	-			<20
	14	.04	870	21-31	19-28	-			<20
	15	.04	870	21-31	19-28	-			<20
250	8	.10	1315	26-46	23-41	-	13	15	35
	9	.07	1190	25-42	22-38	-			30
	10	.06	1085	24-39	21-35	-			20
	11	.06	1085	24-39	21-35	-			20
	12	.06	1085	24-39	21-35	-			20
	13	.06	1085	24-39	21-35	-			20
	14	.06	1085	24-39	21-35	-			20
	15	.06	1085	24-39	21-35	-			20
	16	.06	1085	24-39	21-35	-			20
	17	.06	1085	24-39	21-35	-			20



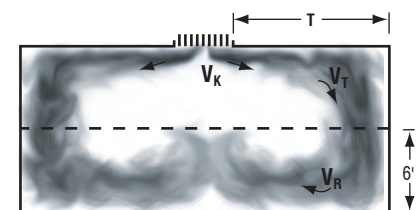
SILL



SIDEWALL



CEILING ONE WAY



CEILING TWO WAY

Outlet Velocity (V _k) FPM										
500	600	700	800	900	1000	1200	1400	1600	1800	2000
Total Pressure (P _t) Inches H ₂ O										
.02	.02	.03	.04	.05	.06	.09	.12	.16	.20	.25

- SYMBOLS
- V_T Terminal Velocity in FPM
 - V_R Room Velocity in FPM
 - V_K Outlet Velocity in FPM
 - A_K Outlet area in Sq. Feet
 - A_N Neck Area in Sq. Ft.
 - P_S Static Pressure H₂O
 - NC Re 8db Room attenuation
 - T Throw in feet at X and Y
 - ΔT Temperature Differential

DATA SHEET

178

ENGINEERING PERFORMANCE DATA

ALS37 3/4" SLOT SUPPLY DIFFUSER



NOTES:

- Table 1 based on 4 ft. diffuser length. For longer lengths, correct throw and NC per Table 2.
- For 2-way ceiling throw, proportion (CFM) and number of slots in each direction of T and select from 1-way data, Table 1.
- When using continuous diffuser lengths with alternating active and inactive sections, a reduction in throw can be obtained by omitting the factors contained in Table 2.
- P_s constant for horizontal 1-way, 2-way and vertical pattern adjustment.
- Supply air temperature effect on horizontal throw is shown in Table 3. Vertical throw at varying supply air temperatures is shown in Table 4.
- Terminal velocities (V_T) at the minimum and maximum Throw (T) positions are rated at 150 FPM and 100 FPM respectively with corresponding room velocities (V_R) of 50 fpm and 35 FPM.

TABLE 2 CONTINUOUS DIFFUSER LENGTH FACTORS

Modify Table 1 by factors for diffuser lengths above 4ft.				
Diffuser Length	Throw (T)			NC
	Ceiling Min.-Max.	Sidewall Min.-Max.	Sill Min.-Max.	
4' - 6'	No Change			+ 0
7' - 20'	T x 1.10			+ 5
21' - 100'	T x 1.15			+ 10

TABLE 4 VERTICAL DOWN-THROW and Supply Temperature Factors

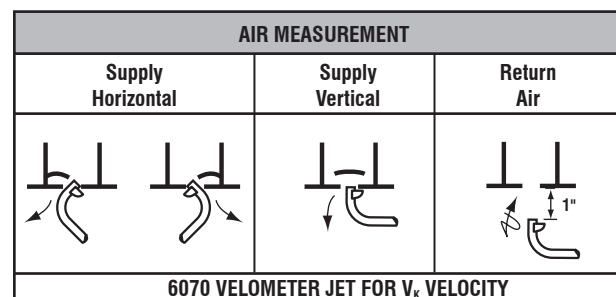
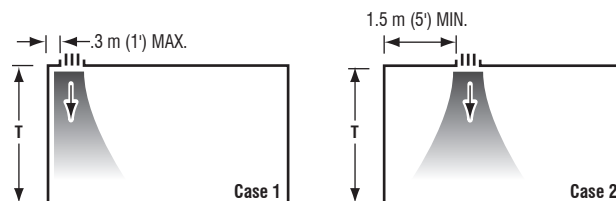
Multiply Throw-Sidewall in Table 1 (or factor in Table 2 if used) by listed value.			
	@ - 11°C ΔT	@ 0°C ΔT	@ +14°C ΔT
	@ - 20F ΔT	@ 0F ΔT	@ +25F ΔT
	Cooling	Ventilating	Heating
Case 1	T x 1.0	T x .90	T x .60
Case 2	T x .70	T x .60	T x .40

TABLE 5 SUPPLY DIFFUSERS AREAS Per Ft. of Length

	No. of Slots							
	1	2	3	4	5	6	7	8
A_N Area	.03	.05	.07	.09	.12	.14	.16	.19
A_K Area	.12	.24	.36	.48	.60	.72	.84	.96

TABLE 3 SUPPLY AIR TEMPERATURE FACTORS

Multiply Throw in Table 1 (or factor in Table 2 if used) by listed value.			
Ceiling Sidewall Sill	@ - 11°C ΔT	@ 0°C ΔT	@ +14°C ΔT
	@ - 20F ΔT	@ 0F ΔT	@ +25F ΔT
	T x 1.0	T x 1.1	T x 1.2



A_K constant for horizontal 1-way, 2-way and vertical pattern.

$$CFM = A_K \times \text{length in feet} \times V_K$$

ENGINEERING PERFORMANCE DATA

ALS30 3/4" SLOT RETURN



TABLE 1 RETURN AIR CFM Per Foot of Length

No. of Slots	A _K Area	NC 20-25		NC 30		NC 35-40	
		Application Non-Ducted		Application Ducted		Application Ducted	
		- .02" P _S CFM	- .03" P _S CFM	- .08" P _S CFM	- .10" P _S CFM	- .15" P _S CFM	- .20" P _S CFM
1	.04	25	35	50	65	75	90
2	.08	50	60	100	110	135	160
3	.12	80	100	160	180	220	250
4	.16	100	120	200	225	275	320
5	.20	130	160	260	295	360	420
6	.24	160	195	320	360	440	510
7	.28	175	215	350	390	475	550
8	.32	200	245	400	445	545	630

Capacity based on diffuser without pattern controller. When pattern controller is used CFM capacities are reduced by 65% at listed P_S, NC and A_K.

HOW TO SPECIFY ARCHITECTURAL LINEAR SLOT DIFFUSERS

Supply Diffuser

Supply and mounting of linear slot diffuser with uniflex pattern and volume controller, series **ALS**. Constructed from powder coater extruded aluminum with 45 degree mitered corners, manufactured by Airvector.

Return

Supply and mounting of linear slot return, series **ALS**. Constructed from powder coater extruded aluminum with 45 degree mitered corners, manufactured by Airvector.

ARCHITECTURAL GRILLES



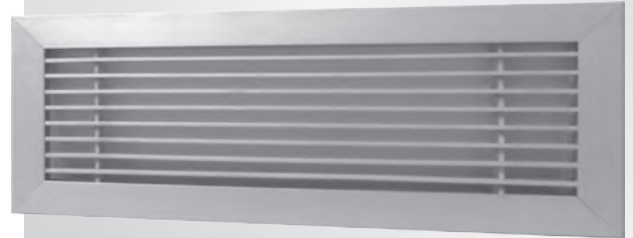
ARCH SERIES Architectural Sidewall Linear Bar Grilles and Registers

Series ARCH - Architectural Sidewall Linear Bar Grilles are designed for installation in the sidewall and are recommended for supplying heated, ventilated, or cooled air, and for returning or exhausting room air. Series ARCH provide a slick look, extreme durability, quick installation and easy access to duct for cleaning and maintenance. All those features combined are what make Series ARCH a best value option for high end residential and commercial applications.

Offered in various finishes to suit all applications, Series ARCH feature a concealed fastening method with no apparent screw holes for a better look. Frame is secured with hidden screw holes in the neck. Removable core is held firmly with sturdy spring clips to avoid any rattling. The Pencil Proof bar style (1/4" bar, 1/2" center-to-center spacing) offers a 50% free are for an optimized balance between aesthetic, security and performance.

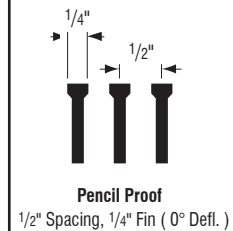
Their reliable performance assures confident use of cooling temperature differentials up to 25°F at predicted low air motion of 35 fpm in the zone of occupancy. Series ARCH Grilles perform efficiently with air loadings of 1 to 2 1/2 CFM per sq.ft. and a sound level range of NC 25 to 35. When installed in the sidewall near the ceiling, Series ARCH Grilles provide a horizontal pattern above the occupied zone.

Series ARCH Grilles are fabricated of high-quality aluminum extrusions. Components are mechanically interlocked for a blemish-free appearance. Opposable Blade Volume dampers are integrally fastened to ARCH7 Registers.

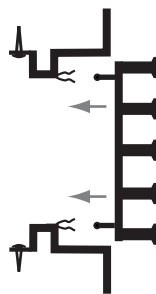
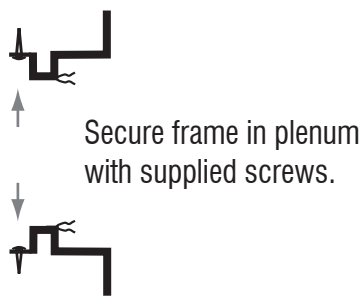


ARCH

Bar Style



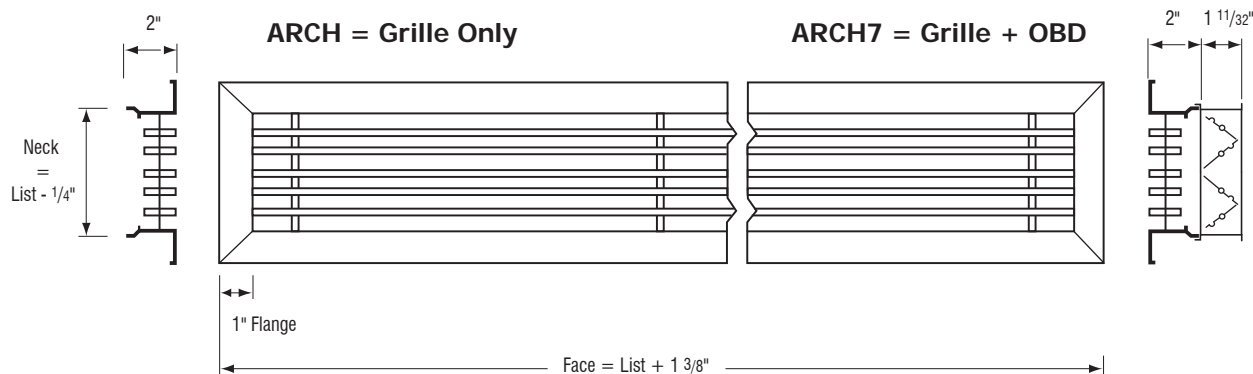
Concealed Screw Holes & Removable Core with Spring Clips - Two Steps Installation



Clip in removable core.

ARCHITECTURAL STYLES

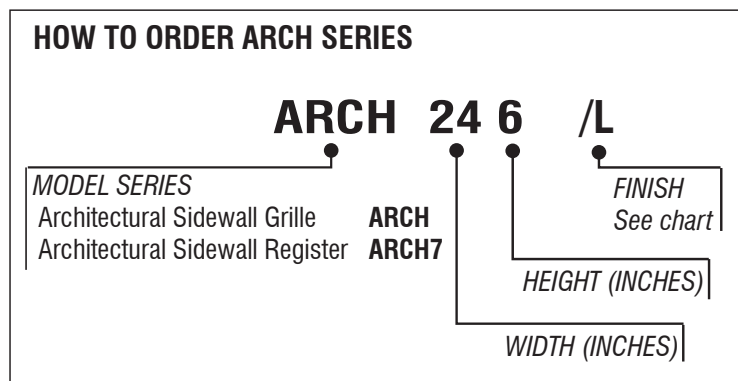
ARCH SERIES



All dimensions in inches.
 Series ARCH products include a 1/32" tolerance for thermal expansion based on a +40°F temperature differential.
 For every +20°F differential above +40°F, reduce required listed length by 1/64" per 5 feet of length.

How to Specify ARCH Series

Supply and mounting of Airvector® Series ARCH architectural sidewall linear bar grille with concealed screw fastening and removable core with clips. Constructed from heavy gauge extruded aluminum.



ENGINEERING PERFORMANCE DATA

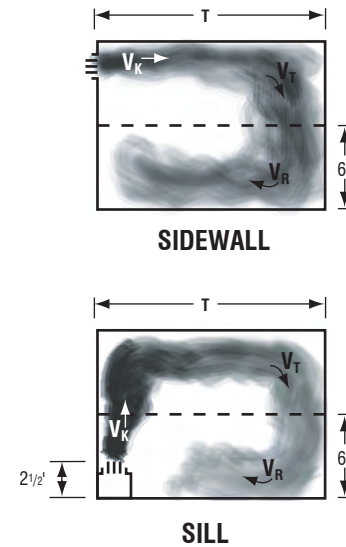
ARCH SERIES



TABLE 1 SUPPLY AIR

CFM per Foot	Listed Width in Inches	Min. P _s in H ₂ O	Outlet Velocity (V _k) FPM	Throw (T) in Feet		Minimum Ceiling Height in Feet		NC
				Sidewall	Sill	in Feet		
				Min.-Max.	Min.-Max.	@-18°F ΔT	@-25°F ΔT	
60	4	.01	425	8-12	2-5	9 1/2	12	<20
70	4	.01	500	10-14	3-7	10	12	<20
80	4	.01	570	11-16	4-9	10 1/2	12 1/2	20
90	4 5	.02 .01	635 520	13-18 11-16	6-11 4-9	11	13	25 20
100	4 5	.03 .01	715 575	14-20 12-18	7-13 5-11	11	13	25 20
120	4 5 6	.04 .03 .01	855 680 550	17-24 15-22 13-19	9-16 7-14 5-11	11 1/2	13	30 25 20
140	4 5 6	.05 .03 .01	1000 810 645	19-28 17-25 15-22	11-20 9-17 7-14	11 1/2	14	30 25 20
160	4 5 6 8	.07 .04 .03 .01	1140 925 735 530	22-32 19-29 18-26 15-22	13-23 10-20 9-17 6-13	12	15	35 30 25 20
180	4 5 6 8	.09 .05 .04 .03	1275 1035 835 600	25-36 22-33 20-30 17-25	16-27 13-24 11-21 8-16	12	15	35 30 25 20
200	4 5 6 8	.11 .07 .05 .03	1425 1150 925 665	28-41 24-36 23-33 20-28	-	12	15	40 35 30 25
250	5 6 8 10	.11 .07 .04 .01	1440 1150 830 635	30-46 27-39 25-35 21-32	-	13	15	40 35 30 25
300	6 8 10 12	.09 .05 .03 .01	1375 1000 765 630	33-48 29-42 25-39 23-33	-	13	15	40 35 30 25
350	8 10 12	.08 .04 .03	1175 900 735	34-48 29-45 26-38	-	13	15	40 35 30
400	8 10 12	.11 .05 .04	1350 1025 845	40-55 33-50 30-44	-	14	16	45 40 35

Terminal velocities (V_T) at the minimum and maximum Throw (T) values are rated at 125 FPM and 75 FPM respectively with corresponding room velocities (V_R) of 50 fpm and 35 FPM.



Outlet Velocity (V _k) FPM										
500	600	700	800	900	1000	1200	1400	1600	1800	2000
Total Pressure (P _T) Inches H ₂ O										
.02	.02	.03	.04	.05	.06	.09	.12	.16	.20	.25

TABLE 2 RETURN AIR (CFM Per Foot of Length)

Listed Width in Inches	A _k Area	NC 20-25 Non-Ducted		NC 25-30 Ducted		NC 30-40 Ducted	
		-.02" P _s	-.03" P _s	-.08" P _s	-.10" P _s	-.15" P _s	-.20" P _s
		CFM	CFM	CFM	CFM	CFM	CFM
4	.34	75	90	150	165	205	235
5	.41	95	120	190	215	260	305
6	.46	120	145	240	265	325	375
8	.57	160	200	325	360	445	515
10	.68	210	255	415	465	570	655
12	.76	255	310	510	565	695	800

- SYMBOLS
- V_T Terminal Velocity in fpm
 - V_R Room Velocity in fpm
 - V_k Outlet Velocity in fpm
 - A_k Outlet area in Sq. Feet
 - A_N Neck Area in Sq. Ft.
 - P_s Static Pressure H₂O
 - P_T Total Pressure H₂O
 - NC Re 8db Room attenuation
 - T Throw in feet at X and Y
 - ΔT Temperature Differential

ENGINEERING PERFORMANCE DATA

ARCH SERIES

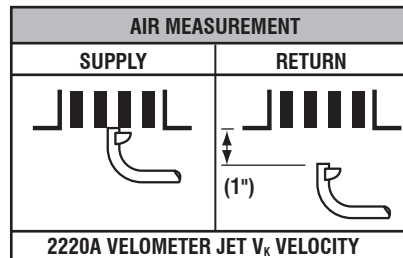


TABLE 3 SUPPLY AIR TEMPERATURE FACTORS

Multiply Throw in Table 1 (or factor in Table 2 if used) by listed value.			
Sidewall Sill	@-20°F ΔT T x 1.10	@ 0°F ΔT T x 1.11	@+25°F ΔT T x 1.12

TABLE 4 SUPPLY GRILLES AREAS Per Ft. of Length

		Listed Width in inches																	
		1.5"	2"	2.5"	3"	4"	5"	6"	8"	10"	12"	14"	16"	18"	20"	24"	30"	36"	
A_N		.13	.17	.21	.25	.33	.42	.50	.67	.84	1.0	1.2	1.3	1.5	1.7	2.0	2.5	3.0	
A_K		.04	.06	.09	.11	.16	.20	.25	.35	.45	.55	.68	.79	.90	1.0	1.3	1.6	2.1	
A_K		.03	.05	.08	.09	.14	.17	.21	.30	.38	.47	.58	.67	.77	.85	1.1	1.4	1.8	



NOTES:

1. ΔP_s static pressure difference inlet to discharge.
2. ΔP_s is the minimum pressure required to deliver CFM shown with the primary damper in wide open position.
3. ΔP_t is the total pressure difference from inlet to discharge.
4. NC level less than 10 shown as (-).

- a) 5 foot lined flex duct (8" diameter).
- b) 5 foot rectangular duct lined with 1" fiberglass insulation.
- c) Space effect factor (2400 ft³) at 5 feet from outlet.
- d) End reflection.
- e) Flow division.

NC levels are derived from tests conducted in accordance with AHRI Standard 880-2008 and are calculated in accordance with AHRI Standard 885-2008 as application data based on the following:

Radiated NC levels are based on :

- a) Plenum / ceiling effect - 5/8" mineral fiber tile, 35 lb / ft³ - 3 foot plenum.
- b) Environmental adjustment factor.

*Not in the AHRI 880 Certification Program.

Inlet Size (Inches)	CFM per Foot	Min. ΔP_s (Damper Full Open)				1.0" ΔP_s			1.5" ΔP_s			3.0" ΔP_s		
		Min. ΔP_s	ΔP_t	Disch. NC	Rad. NC	ΔP_t	Disch. NC	Rad. NC	ΔP_t	Disch. NC	Rad. NC	ΔP_t	Disch. NC	Rad. NC
		Basic Units												
5	75	.03	.05	-	-	1.02	-	-	1.52	-	13	3.020	13	20
	100	.05	.09	-	-	1.04	-	11	1.54	10	13	3.035	13	20
	200	.19	.33	-	-	1.14	19	19	1.64	22	22	3.142	25	24
	300	.43	.75	13	19	1.32	28	24	1.82	30	28	3.319	33	30
	350	.43	.99	14	22	1.44	28	27	1.94	30	28	3.435	34	32
6	110	.02	.04	-	-	1.02	-	13	1.52	-	17	3.020	14	24
	200	.07	.14	-	-	1.06	16	19	1.56	18	19	3.064	21	25
	300	.15	.29	-	-	1.14	20	22	1.64	24	24	3.144	30	26
	400	.27	.53	-	13	1.26	22	22	1.76	24	26	3.256	34	31
	500	.40	.80	15	19	1.40	26	27	1.94	27	28	3.400	35	33
7	140	.01	.03	-	-	1.02	-	10	1.52	-	13	3.017	15	20
	200	.02	.06	-	-	1.03	14	13	1.53	16	16	3.034	19	20
	400	.09	.23	-	-	1.14	18	20	1.64	23	23	3.136	34	31
	600	.21	.51	-	15	1.31	26	27	1.81	26	30	3.306	34	34
	700	.26	.67	-	18	1.42	22	30	1.92	26	31	3.416	33	35
8	185	.01	.03	-	-	1.02	10	14	1.52	11	15	3.018	17	20
	400	.04	.11	-	-	1.07	17	19	1.57	21	24	3.073	27	31
	600	.08	.25	-	-	1.16	19	23	1.66	25	27	3.164	35	36
	800	.14	.43	-	13	1.29	22	25	1.80	27	30	3.291	36	37
	1000	.21	.67	11	20	1.46	25	28	1.96	29	32	3.455	36	38
10	300	.01	.02	-	-	1.02	15	20	1.52	16	22	3.016	21	25
	500	.01	.06	-	-	1.05	17	21	1.54	24	27	3.045	28	34
	800	.02	.14	-	-	1.11	17	23	1.61	23	27	3.114	34	38
	1200	.05	.30	-	15	1.26	24	30	1.76	28	31	3.257	33	36
	1500	.07	.47	10	22	1.40	28	31	1.90	31	35	3.401	36	39
12	430	-	.02	-	-	1.02	17	22	1.52	19	25	3.015	22	28
	800	-	.06	-	-	1.05	15	23	1.55	23	28	3.053	34	36
	1200	.01	.13	-	-	1.12	18	24	1.62	22	28	3.119	34	36
	1800	.01	.27	-	23	1.27	22	27	1.77	27	32	3.269	34	37
	2300	.02	.45	14	31	1.44	25	30	1.94	29	33	3.439	36	40
14	600	.004	.02	-	-	1.02	17	20	1.52	23	24	3.017	28	31
	1000	.006	.05	-	-	1.05	17	22	1.55	24	27	3.046	35	35
	1600	.011	.13	-	10	1.12	19	22	1.62	24	27	3.118	35	35
	2400	.024	.29	10	25	1.27	27	30	1.76	28	35	3.265	35	38
	3100	.036	.48	21	32	1.44	31	35	1.94	34	35	3.442	38	39
16	780	.01	.02	-	-	1.02	16	21	1.57	19	25	3.018	23	43
	1600	.02	.08	-	-	1.07	17	21	1.57	22	27	3.066	35	28
	2400	.04	.19	-	19	1.15	22	28	1.65	25	31	3.148	35	37
	3600	.09	.42	24	30	1.33	31	30	1.83	25	35	3.333	37	36
	4200	.12	.57	25	35	1.45	35	36	1.95	37	36	3.453	41	43
18	1100	-	.02	-	-	1.02	16	22	1.51	19	24	3.014	25	32
	2300	.01	.07	-	-	1.06	21	27	1.56	28	30	3.063	36	39
	3600	.02	.18	16	35	1.16	25	31	1.65	30	35	3.155	38	41
	4500	.04	.28	22	38	1.24	31	39	1.74	34	40	3.241	40	44
	5500	.06	.42	31	42	1.36	36	41	1.86	38	43	3.361	42	48
24	1480	-	.01	-	-	1.01	21	32	1.51	27	37	3.011	30	46
	3200	.04	.04	-	22	1.05	22	31	1.55	27	36	3.050	37	48
	4800	.04	.09	21	38	1.11	28	35	1.61	30	37	3.112	38	45
	6000	.14	.14	28	40	1.18	33	39	1.68	35	41	3.175	40	48
	7300	.20	.21	37	47	1.26	36	41	1.76	40	46	3.260	44	48

SYMBOLS:

- PT Total Pressure H2O
- PS Static Pressure H2O
- NC Re 8db Room attenuation
- Δ Differential

ROUND DIFFUSERS



MODEL DCG ADJUSTABLE ROUND DIFFUSER

MODEL DCG - Aluminum Adjustable Round Diffuser

Airvector®'s DCG Aluminum Adjustable Round Diffusers are recommended for heating, ventilating, and cooling applications. DCG diffusers provide a 360° air diffusion pattern and excellent performance in VAV systems.

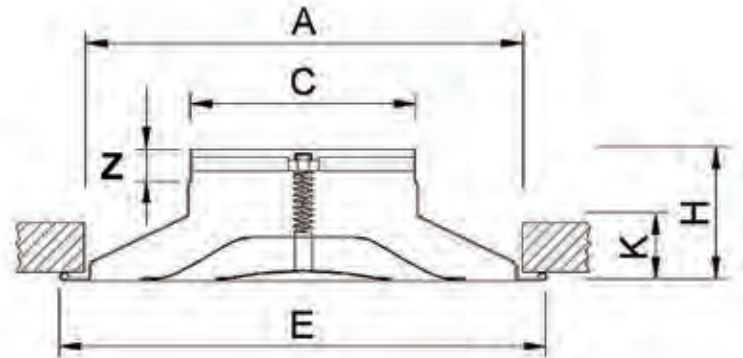
Full adjustability is possible by rotating the inner core clockwise or counterclockwise to move the cones up or down, changing from horizontal projection to vertical projection in accordance with the supply air temperature and reducing stratification. DCG diffusers provide great performance in temperatures differentials up to 54°F (12°C) and are suitable for premises with ceilings 8.5 ft (2.6 m) and higher. Original design by Lievore, Altherr & Molina for Madel.



DCG
by **MADEL**

Highlights

- Heavy-gauge aluminum construction
- Fully adjustable
- Powder paint coating - White (Custom Finishes Avail.)
- Available in Imperial and Metric dimensions



Imperial

Listed Size	Duct Size	A (in)	C (in)	E (in)	H (in)	K (in)	Z (in)
06	6"	19 59/64	5 3/4	13 5/16	4 15/16	1 47/64	1
08	8"	15 5/32	7 3/4	16 47/64	4 17/32	2 9/32	1
10	10"	18 17/64	9 3/4	19 3/8	4 31/64	2 1/4	1
12	12"	22 13/64	11 3/4	23 17/64	6 19/32	3 5/32	1
14	14"	24 13/16	13 29/32	26 1/16	5 33/64	3 17/64	1
16	16"	24 13/16	15 43/64	26 1/16	5 5/32	2 59/64	1
18	18"	31 7/32	17 19/32	32 3/4	6 13/16	4 11/64	1
20	20"	31 7/32	19 9/16	32 3/4	6 27/64	3 13/16	1

Metric

Listed Size	Duct Size	A (mm)	C (mm)	E (mm)	H (mm)	K (mm)	Z (mm)
160	160 mm	303	157	331	101	44	25
200	200 mm	385	197	425	115	58	25
250	250 mm	464	247	492	114	57	25
315	315 mm	564	313	591	137	80	25
355	355 mm	630	353	662	140	83	25
400	400 mm	630	398	662	131	74	25
450	450 mm	793	447	832	173	106	25
500	500 mm	793	497	832	163	97	25

ENGINEERING PERFORMANCE DATA

MODEL DCG ADJUSTABLE ROUND DIFFUSER



Recommended Velocity and CFM

Neck Diameter	Free Area (sqft)	Vmin (fpm)	Vmax (fpm)	Min cfm	Max cfm
6" (160 mm)	0.215	590	1122	126	241
8" (200 mm)	0.338	590	1142	200	388
10" (250 mm)	0.527	590	886	312	468
12" (315 mm)	0.839	590	1122	491	950
14" (355 mm)	1.035	590	1220	609	1279
16" (400 mm)	1.345	590	1181	794	1606
18" (450 mm)	1.711	590	886	917	1561
20" (500 mm)	2.110	590	886	1112	1858

Isothermal Performance Data in Horizontal Flow Position

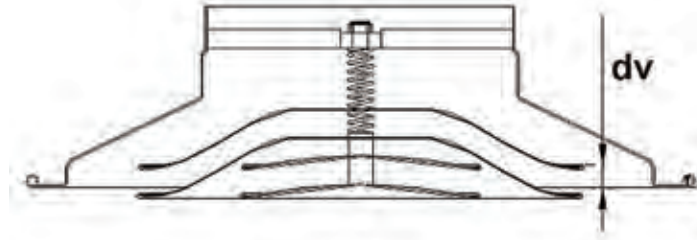
SIZE	Neck Velocity (fpm)	400	500	600	700	800	1000	1200	1400	1600
	Velocity Pressure (in H ₂ O)	.010	.016	.023	.031	.040	.063	.090	.122	.160
6" 160 mm	CFM	79	98	118	137	157	196	236	275	314
	Pressure Loss (in wg.)	.032	.044	.060	.080	.104	.153	.241	.301	.402
	NC	< 15	< 15	< 20	20	< 20	30	< 35	> 35	> 35
	Throw - Radius (ft)	4	5	6	9	11	13	17	20	25
8" 200 mm	CFM	140	175	209	244	279	349	419	489	559
	Pressure Loss (in wg.)	.028	.036	.056	.072	.096	.149	.209	.281	.361
	NC	< 15	< 15	< 20	30	< 35	< 35	35	> 35	> 35
	Throw - Radius (ft)	5	7	9	11	12	14	17	19	22
10" 250 mm	CFM	218	273	327	382	436	545	654	764	873
	Pressure Loss (in wg.)	.040	.060	.092	.120	.161	.249	.402	.602	-
	NC	< 15	< 15	< 20	< 25	< 30	35	> 35	> 35	-
	Throw - Radius (ft)	7	9	11	13	15	20	25	33	-
12" 315 mm	CFM	314	393	471	550	628	785	942	1100	1257
	Pressure Loss (in wg.)	.040	.056	.096	.129	.201	.309	.482	.703	-
	NC	< 15	< 20	< 30	30	< 40	> 40	> 40	> 40	-
	Throw - Radius (ft)	11	12	14	16	17	19	22	-	-
14" 355 mm	CFM	428	535	641	748	855	1069	1283	1497	1710
	Pressure Loss (in wg.)	.032	.052	.072	.108	.149	.221	.361	.482	.602
	NC	< 15	20	25	< 30	< 35	< 40	> 40	> 40	> 40
	Throw - Radius (ft)	10	12	15	17	18	21	26	27	-
16" 400 mm	CFM	559	698	838	977	1117	1396	1676	1955	2234
	Pressure Loss (in wg.)	.044	.072	.108	.129	.145	.241	.321	.462	.562
	NC	< 15	< 25	< 30	< 35	35	> 40	> 40	> 40	> 40
	Throw - Radius (ft)	11	14	15	16	17	19	21	-	-
18" 450 mm	CFM	707	884	1060	1237	1414	1767	2121	2474	-
	Pressure Loss (in wg.)	.052	.064	.116	.157	.221	.361	.542	.803	-
	NC	< 20	< 25	< 30	< 35	< 40	> 40	> 40	> 40	-
	Throw - Radius (ft)	13	15	17	18	19	22	25	-	-
20" 500 mm	CFM	873	1091	1309	1527	1745	2182	2618	-	-
	Pressure Loss (in wg.)	.039	.060	.080	.100	.141	.233	.321	-	-
	NC	25	< 3	< 35	35	< 40	> 40	> 40	-	-
	Throw - Radius (ft)	13	15	17	19	21	25	29	-	-
Downward Projection of Heated Air (in ft)	10 Degrees F Diff.	6 - 6	8 - 8	10 - 12	13 - 15	15 - 19	19 - 25	21 - 32	25 - 38	27 - 40
	20 Degrees F Diff.	4 - 4	6 - 7	7 - 8	9 - 11	10 - 14	13 - 18	15 - 17	17 - 25	19 - 29
	30 Degrees F Diff.	3 - 3	5 - 5	6 - 7	7 - 9	9 - 11	11 - 15	13 - 18	14 - 20	15 - 24
	40 Degrees F Diff.	3 - 2	4 - 4	5 - 6	7 - 8	8 - 10	10 - 13	11 - 16	12 - 18	14 - 20

Performance Notes

- NC value based on 10 db room attenuation
- Throw values are based on isothermal air and terminal velocity of 40 fpm
- For exposed duct application, multiply throw values by 0.7
- Downward Projection of Heated Air values represent the distance to a total air velocity of essentially zero. The two values are for 6" neck and 12" neck. In horizontal position.

ENGINEERING PERFORMANCE DATA

Vertical Flow Adjustment



SIZE	Neck Velocity (fpm)	400	500	600	700	800	1000	1200	1400	1600
6" 160 mm	CFM	79	98	118	137	157	196	236	275	314
	dv = 13/64" (5 mm)	5 - x	7 - x	9 - x	11 - x	12 - 5	16 - 8	20 - 10	23 - 11	28 - 13
	dv = 5/16" (8 mm)	8 - x	10 - x	12 - 5	15 - 7	18 - 9	22 - 11	28 - 13	33 - 16	x - 19
	dv = 19/32" (15 mm)	12 - x	15 - 7	17 - 9	22 - 11	25 - 13	32 - 16	x - 19	x - 23	x - 28
8" 200 mm	CFM	140	175	209	244	279	349	419	489	559
	dv = 5/16" (8 mm)	9 - 3	11 - 5	12 - 7	13 - 8	14 - 9	17 - 10	19 - 11	x - 13	x - 14
	dv = 25/64" (10 mm)	12 - 7	14 - 8	16 - 9	17 - 11	18 - 11	22 - 13	25 - 15	x - 17	x - 18
	dv = 29/32" (23 mm)	16 - 10	19 - 11	21 - 13	24 - 14	25 - 15	31 - 18	33 - 20	x - 23	x - 25
10" 250 mm	CFM	218	273	327	382	436	545	654	764	873
	dv = 13/64" (5 mm)	11 - x	12 - 5	14 - 7	16 - 8	18 - 9	21 - 11	x - 13	x - 15	x - 18
	dv = 25/64" (10 mm)	15 - 7	17 - 9	20 - 11	22 - 12	25 - 13	30 - 15	x - 19	x - 22	x - 25
	dv = 45/64" (18 mm)	19 - 10	22 - 11	25 - 14	28 - 15	32 - 16	x - 20	x - 23	x - 28	x - 31
12" 315 mm	CFM	314	393	471	550	628	785	942	-	-
	dv = 33/64" (13 mm)	11 - 6	14 - 7	18 - 10	21 - 13	28 - 16	x - 19	x - 25	-	-
	dv = 25/32" (20 mm)	16 - 8	19 - 10	25 - 14	30 - 17	38 - 21	x - 27	x - 36	-	-
	dv = 1 1/16" (27 mm)	21 - 12	26 - 15	36 - 19	41 - 23	54 - 28	x - 38	x - 51	-	-
14" 355 mm	CFM	428	535	641	748	855	1069	1283	1497	-
	dv = 25/64" (10 mm)	7 - 3	9 - 6	12 - 8	15 - 9	18 - 11	21 - 15	30 - 19	x - 21	-
	dv = 19/32" (15 mm)	11 - 6	15 - 10	19 - 13	23 - 15	29 - 18	36 - 22	51 - 31	x - 36	-
	dv = 29/32" (23 mm)	18 - 10	22 - 15	30 - 19	36 - 23	44 - 27	59 - 35	x - 49	x - 56	-
16" 400 mm	CFM	559	698	838	977	1117	1396	1676	1955	-
	dv = 13/64" (5 mm)	13 - 9	16 - 11	20 - 13	21 - 15	25 - 16	28 - 19	x - 23	x - 26	-
	dv = 5/16" (8 mm)	18 - 12	22 - 16	27 - 18	30 - 20	x - 22	x - 28	x - 33	-	-
	dv = 35/64" (14 mm)	24 - 16	31 - 21	x - 24	x - 27	x - 30	-	-	-	-
18" 450 mm	CFM	707	884	1060	1237	1414	1767	2121	2474	-
	dv = 45/64" (18 mm)	17 - 10	20 - 11	22 - 13	25 - 15	28 - 17	x - 20	x - 22	x - 25	-
	dv = 63/64" (25 mm)	24 - 14	27 - 16	31 - 18	x - 20	x - 23	x - 27	x - 31	-	-
	dv = 1 3/8" (35 mm)	29 - 17	32 - 19	x - 22	x - 25	x - 27	x - 32	-	-	-
20" 500 mm	CFM	873	1091	1309	1527	17465	2182	2618	-	-
	dv = 45/64" (18 mm)	12 - 8	15 - 10	17 - 11	19 - 12	21 - 14	x - 16	x - 19	-	-
	dv = 63/64" (25 mm)	15 - 10	19 - 12	21 - 13	24 - 15	27 - 17	x - 20	x - 24	-	-
	dv = 1 3/8" (35 mm)	21 - 13	26 - 16	30 - 18	33 - 20	x - 23	x - 28	x - 33	-	-

Performance Notes

- Vertical throw values (in ft) are for isothermal (first value) and for a temperature difference of 9°F (5°C) in heating mode (second value), at terminal velocity of 40 fpm.
- **dv** is the vertical adjustment of the diffuser core and is measured by the core offset towards the inside of the diffuser, compared to its original horizontal position.
- **x** means the value is not available.

How to Specify DCG Series

Supply and mounting of adjustable round diffuser series DCG, constructed from aluminum and powder coated in white M9016. Full vertical adjustability provided by rotating the core clockwise or counterclockwise. By Airvector Specialty Products/MADEL.

ENGINEERING PERFORMANCE DATA



HOW TO ORDER DCG ROUND DIFFUSERS

DCG 08

MODEL SERIES

Fully Adjustable Aluminum **DCG**

ROUND NECK

	Imperial		Metric
6"	06	160 mm	160
8"	08	200 mm	200
10"	10	250 mm	250
12"	12	315 mm	315
14"	14	355 mm	355
16"	16	400 mm	400
18"	18	450 mm	450
20"	20	500 mm	500

SQUARE DIFFUSERS



MODELS DF3, DF3D, DF3I, & DA3 3 CONE DIFFUSERS

- MODEL DF3 - Fixed horizontal pattern
- MODEL DF3D - Fixed horizontal pattern, 2" high collar
- MODEL DF3I - Fixed horizontal pattern, Insulated
- MODEL DA3 - Adjustable horizontal pattern

Airvector's 3 Cone Supply Diffusers are recommended for heating, ventilating, and cooling. The diffusers' integrated round-neck-to-square-face construction can provide a 360° horizontal air diffusion pattern similar to a full round diffuser. The DA3 diffuser allows for independent adjustable horizontal deflection. The DF3I is supplied with R6 insulation and does not include an integrated collar. R4 and R6 are optional for DF3, DF3D, and DA3.

High diffusion induction rates result in rapid temperature and velocity equalization of the mixed air mass well above the zone of occupancy. Horizontal performance assures confident use of a cooling temperature differential of 30° and greater at a predicted low air motion of 35 fpm in the zone of occupancy. DF3 supply diffusers perform efficiently with air loadings of 6 to 30 air changes per hour (based on a 10 ft. ceiling height), and a sound level range of NC 25 to 35.

Highlights

- Heavy-gauge all-steel construction
- Powder paint coating - White (Custom Finishes Avail.)
- Matching N4 and N5 OBDs available
- OBD accessible through diffuser face

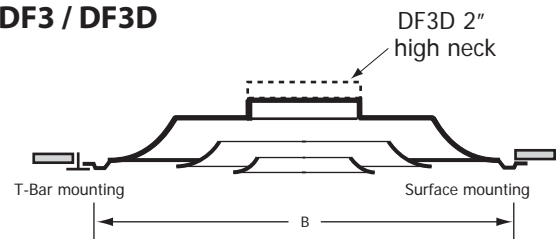


DF3

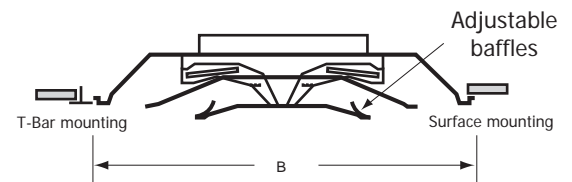
HANDY FEATURES

- One standard model suits both T-Bar and Drywall installations using rigid ducts
- Compatible with Airvector's exclusive Easy Install PF frame
- Core is easily removable without tools to facilitate access to duct.

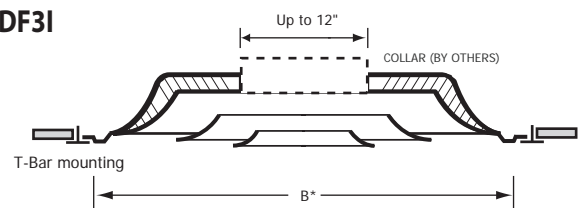
DF3 / DF3D



DA3



DF3I



Listed Size	Neck Dia	Nominal Face Size	Overall Face Size "B"	Drywall Ceiling Opening
1206*	6	12 x 12	11 ³ / ₄ x 11 ³ / ₄	10 ¹ / ₂ x 10 ¹ / ₂
1208*	8	12 x 12	23 ³ / ₄ x 23 ³ / ₄	10 ¹ / ₂ x 10 ¹ / ₂
2406	6	24 x 24	23 ³ / ₄ x 23 ³ / ₄	22 ¹ / ₂ x 22 ¹ / ₂
2408	8	24 x 24	23 ³ / ₄ x 23 ³ / ₄	22 ¹ / ₂ x 22 ¹ / ₂
2410	10	24 x 24	23 ³ / ₄ x 23 ³ / ₄	22 ¹ / ₂ x 22 ¹ / ₂
2412	12	24 x 24	23 ³ / ₄ x 23 ³ / ₄	22 ¹ / ₂ x 22 ¹ / ₂
2414*	14	24 x 24	23 ³ / ₄ x 23 ³ / ₄	22 ¹ / ₂ x 22 ¹ / ₂

* Only available with DF3 and DA3

ENGINEERING PERFORMANCE DATA

MODELS DF3, DF3D, DF3I, & DA3 ³ CONE AIRVECTOR®

12" x 12" face

SIZE (inches)	Neck Velocity (fpm)	400	500	600	700	800	1000	1200	1400	1600
	Velocity Pressure (in H ₂ O)	.010	.016	.022	.031	.041	.062	.090	.122	.160
6	CFM	78	98	118	137	157	196	235	274	313
	Total Pressure	.02	.03	.04	.06	.07	.10	.16	.22	.29
	NC	< 20	< 20	< 20	< 20	< 20	25	29	34	40
	Throw (ft)	2-3-6	3-4-7	4-5-9	4-5-10	5-6-11	6-8-12	7-9-13	8-10-15	9-11-16
8	CFM	140	175	209	244	279	349	419	489	559
	Total Pressure	.03	.04	.06	.07	.09	.14	.20	.28	.38
	NC	< 20	< 20	< 20	< 20	< 20	29	35	41	45
	Throw (ft)	2-4-7	3-5-9	4-7-10	5-8-11	6-9-12	7-10-14	8-12-17	10-12-18	11-14-20

24" x 24" face

SIZE (inches)	Neck Velocity (fpm)	400	500	600	700	800	1000	1200	1400	1600
	Velocity Pressure (in H ₂ O)	.010	.016	.022	.031	.041	.062	.090	.122	.160
6	CFM	78	98	118	137	157	196	235	274	313
	Total Pressure	.02	.03	.04	.05	.07	.10	.14	.19	.24
	NC	< 20	< 20	< 20	< 20	< 20	22	28	32	36
	Throw (ft)	1-2-4	1-3-4	2-3-5	2-3-6	3-4-7	4-6-8	5-7-10	6-9-11	7-9-12
8	CFM	140	175	209	244	279	349	419	489	559
	Total Pressure	.02	.03	.04	.05	.08	.10	.15	.20	.25
	NC	< 20	< 20	< 20	< 20	< 20	26	31	36	41
	Throw (ft)	2-3-5	2-3-7	3-4-8	3-5-8	4-6-9	5-7-11	6-9-13	7-10-14	8-11-17
10	CFM	218	273	327	382	436	545	654	763	872
	Total Pressure	.02	.03	.04	.05	.08	.12	.17	.24	.30
	NC	< 20	< 20	< 20	< 20	22	29	34	38	43
	Throw (ft)	3-4-6	4-5-8	4-6-10	5-7-12	6-8-14	7-9-15	8-11-16	9-12-17	10-13-19
12	CFM	314	393	471	550	628	785	941	1099	1246
	Total Pressure	.02	.04	.05	.07	.09	.14	.20	.27	.36
	NC	< 20	< 20	< 20	20	23	39	36	41	46
	Throw (ft)	4-5-9	5-6-10	6-7-11	6-8-13	7-9-15	8-11-18	10-13-21	12-16-22	13-18-21
14	CFM	492>	615	738	861	984	1230	1476	1722	1968
	Total Pressure	.03	.04	.06	.08	.10	.18	.23	.30	.40
	NC	< 20	< 20	< 20	21	25	33	38	43	48
	Throw (ft)	4-6-10	5-6-11	6-8-14	7-10-16	8-11-18	10-14-20	12-16-22	14-19-24	15-20-26

NC Value based on 10 db room attenuation.

Throw Values are based on isothermal air and terminal velocities of 150 fpm, 100 fpm & 75 fpm respectively.

Total Pressure the sum of static pressure plus velocity pressure and is given in inches w.g.

HOW TO ORDER DF3 & DF4 SERIES

DF3-R4-S-W3 2408 /W

MODEL SERIES

- 3 Cone Fixed **DF3**
- 3 Cone Fixed, 2" Neck, **DF3D**
- ... Single-Box
- 3 Cone Adjustable **DA3**
- 4 Cone Fixed **DF4**
- 4 Cone Fixed, 2" Neck, **DF4D**
- ... Single-Box
- 4 Cone Adjustable **DA4**

INSULATION (OPTIONAL)

Standard is uninsulated

- R4.2 Taped Insulation **-R4**
- R6 Taped Insulation **-R6**

PACKAGING (OPTIONAL)

Standard is 2 per box

- Single Box **-S**

FINISH (OPTIONAL)
Standard is White (**/W**)
See chart for more

NECK DIAMETER
In Inches
06-08-10-12-14"

FACE DIMENSIONS
12" x 12" **12**
24" x 24" **24**

DIRECTION (OPTIONAL)
Standard is 4 Way

- 1 Way **-W1**
- 2 Way Corner **-WC**
- 2 Way Opposed **-WO**
- 3 Way **-W3**

HOW TO ORDER DF3I & DF4I

DF3I-S /W

MODEL SERIES

- 3 Cone **DF3I**
- 4 Cone **DF4I**

PACKAGING (OPTIONAL)
Standard is 2 per box
Single Box **-S**

FINISH (OPTIONAL)
Standard is White (**/W**)
See chart for more

SQUARE DIFFUSERS



MODELS DF4, DF4D, DF4I, & DA4 4 CONE DIFFUSERS

MODEL DF4 - Fixed horizontal pattern

MODEL DF4D - Fixed horizontal pattern, 2" high collar

MODEL DF4I - Fixed horizontal pattern, Insulated

MODEL DA4 - Adjustable horizontal pattern

Airvector's 4 Cone Supply Diffusers are recommended for heating, ventilating, and cooling. The DF4, DF4D, and DA4 integrated round-neck-to-square-face construction provides a 360° horizontal air diffusion pattern similar to a full round diffuser. The DA4 diffuser allows independent adjustable horizontal deflection. The DF4I is supplied with R6 insulation and does not include an integrated collar. R4 and R6 are optional for DF4, DF4D, and DA4.

High diffusion induction rates result in rapid temperature and velocity equalization of the mixed air mass well above the zone of occupancy. Horizontal performances assure confident use of cooling temperature of 30°F and greater at predicted low air motion of 35 fpm in the zone of occupancy. DF4 Supply Diffusers perform efficiently with air loadings of 6 to 30 air changes per hour (based on 10ft. ceiling height), and sound level range of NC 25 to 35.

FEATURES

- Full face 24" x 24" for all neck sizes. (12" x 12" face available in 3 cone only)
- Heavy-gauge all-steel construction
- DF4D available with 2" high neck
- Powder paint coating - White (Custom finishes avail.)
- Matching N4 and N5 OBDs available
- Screw driver adjustment of OBD through diffuser face.

Listed Size	Neck Dia	Nominal Face Size	Overall Face Size "B"	Drywall Ceiling Opening
2406	6	24 x 24	23 ³ / ₄ x 23 ³ / ₄	22 ¹ / ₂ x 22 ¹ / ₂
2408	8	24 x 24	23 ³ / ₄ x 23 ³ / ₄	22 ¹ / ₂ x 22 ¹ / ₂
2410	10	24 x 24	23 ³ / ₄ x 23 ³ / ₄	22 ¹ / ₂ x 22 ¹ / ₂
2412	12	24 x 24	23 ³ / ₄ x 23 ³ / ₄	22 ¹ / ₂ x 22 ¹ / ₂
2414*	14	24 x 24	23 ³ / ₄ x 23 ³ / ₄	22 ¹ / ₂ x 22 ¹ / ₂

* Only available with DF4 and DA4

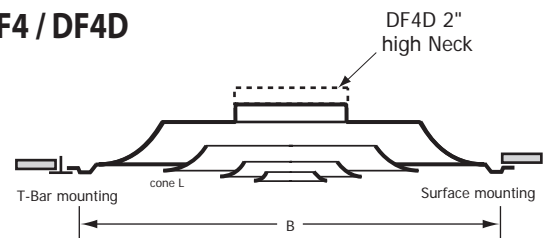


DF4

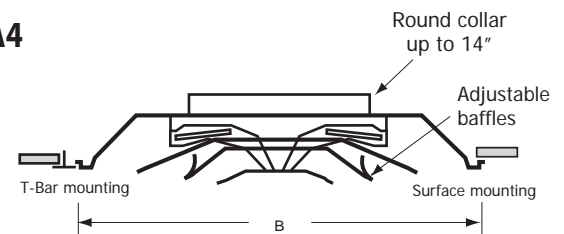
HANDY FEATURES:

- Compatible with Airvector's exclusive Easy Install Plaster Frame - model PF.
- Core is easily removable without tools to facilitate access to duct
- One standard model suits both T-Bar and Drywall installations using rigid ducts

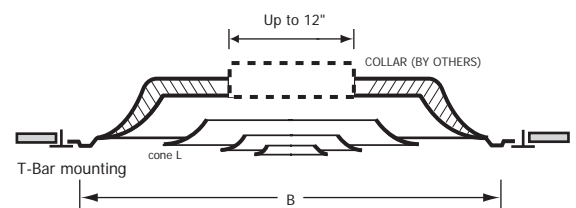
DF4 / DF4D



DA4



DF4I



ENGINEERING PERFORMANCE DATA

MODEL DF4, DF4D, DA4, & DF4I

4 CONE



24" x 24" face

SIZE (inches)	Neck Velocity (fpm)	400	500	600	700	800	1000	1200	1400	1600
	Velocity Pressure (in H ₂ O)	.010	.016	.022	.031	.041	.062	.090	.122	.160
6	CFM	78	98	118	137	157	196	235	274	313
	Total Pressure	.02	.03	.04	.05	.07	.10	.14	.19	.24
	NC	< 20	< 20	< 20	< 20	< 20	22	28	32	36
	Throw (ft)	1-2-4	1-3-4	2-3-5	2-3-6	3-4-7	4-6-8	5-7-10	6-9-11	7-9-12
8	CFM	140	175	209	244	279	349	419	489	559
	Total Pressure	.02	.03	.04	.05	.08	.10	.15	.20	.25
	NC	< 20	< 20	< 20	< 20	< 20	26	31	36	41
	Throw (ft)	2-3-5	2-3-7	3-4-8	3-5-8	4-6-9	5-7-11	6-9-13	7-10-14	8-11-17
10	CFM	218	273	327	382	436	545	654	763	872
	Total Pressure	.02	.03	.04	.05	.08	.12	.17	.24	.30
	NC	< 20	< 20	< 20	< 20	22	29	34	38	43
	Throw (ft)	3-4-6	4-5-8	4-6-10	5-7-12	6-8-14	7-9-15	8-11-16	9-12-17	10-13-19
12	CFM	314	393	471	550	628	785	941	1099	1246
	Total Pressure	.02	.04	.05	.07	.09	.14	.20	.27	.36
	NC	< 20	< 20	< 20	20	23	39	36	41	46
	Throw (ft)	4-5-9	5-6-10	6-7-11	6-8-13	7-9-15	8-11-18	10-13-21	12-16-22	13-18-21
14	CFM	492>	615	738	861	984	1230	1476	1722	1968
	Total Pressure	.03	.04	.06	.08	.10	.18	.23	.30	.40
	NC	< 20	< 20	< 20	21	25	33	38	43	48
	Throw (ft)	4-6-10	5-6-11	6-8-14	7-10-16	8-11-18	10-14-20	12-16-22	14-19-24	15-20-26

NC Value based on 10 db room attenuation.

Throw Values are based on isothermal air and terminal velocities of 150 fpm, 100 fpm & 75 fpm respectively.

Total Pressure the sum of static pressure plus velocity pressure and is given in inches w.g.

HOW TO ORDER DF3 & DF4 SERIES

DF4-R4-S-W3 2408 /W

MODEL SERIES

- 3 Cone Fixed **DF3**
- 3 Cone Fixed, 2" Neck, **DF3D**
- ... Single-Box
- 3 Cone Adjustable **DA3**
- 4 Cone Fixed **DF4**
- 4 Cone Fixed, 2" Neck, **DF4D**
- ... Single-Box
- 4 Cone Adjustable **DA4**

INSULATION (OPTIONAL)

- Standard is uninsulated
- R4.2 Taped Insulation **-R4**
- R6 Taped Insulation **-R6**

PACKAGING (OPTIONAL)

- Standard is 2 per box
- Single Box **-S**

FINISH (OPTIONAL)
Standard is White (/W)
See chart for more

NECK DIAMETER
In Inches
06-08-10-12-14"

FACE DIMENSIONS
12" x 12" **12**
24" x 24" **24**

DIRECTION (OPTIONAL)
Standard is 4 Way

- 1 Way **-W1**
- 2 Way Corner **-WC**
- 2 Way Opposed **-WO**
- 3 Way **-W3**

HOW TO ORDER DF4I & DF3I

DF4I-S /W

MODEL SERIES

- 3 Cone **DF3I**
- 4 Cone **DF4I**

PACKAGING (OPTIONAL)

- Standard is 2 per box
- Single Box **-S**

FINISH (OPTIONAL)
Standard is White (/W)
See chart for more

SERIES DLA, DLAM & DLAI



MODEL SERIES DLA, DLAM & DLAI

Aluminum Louvered Face Diffusers Fixed Directional Pattern, High Capacity

DLA aluminum supply diffusers are recommended for heating, ventilating and cooling.

Designed for high capacity, Airvector®'s Model Series DLA can supply large volumes of air at low sound levels and pressure drops. DLA directional diffusers are offered in all standard square dimensions with a variety of cores to provide any required air pattern.

DLA Series feature a square neck, **DLAM** Series feature a round neck and **DLAI** Series feature an R6 insulated back, pre-scored for 6"-14" round collars.

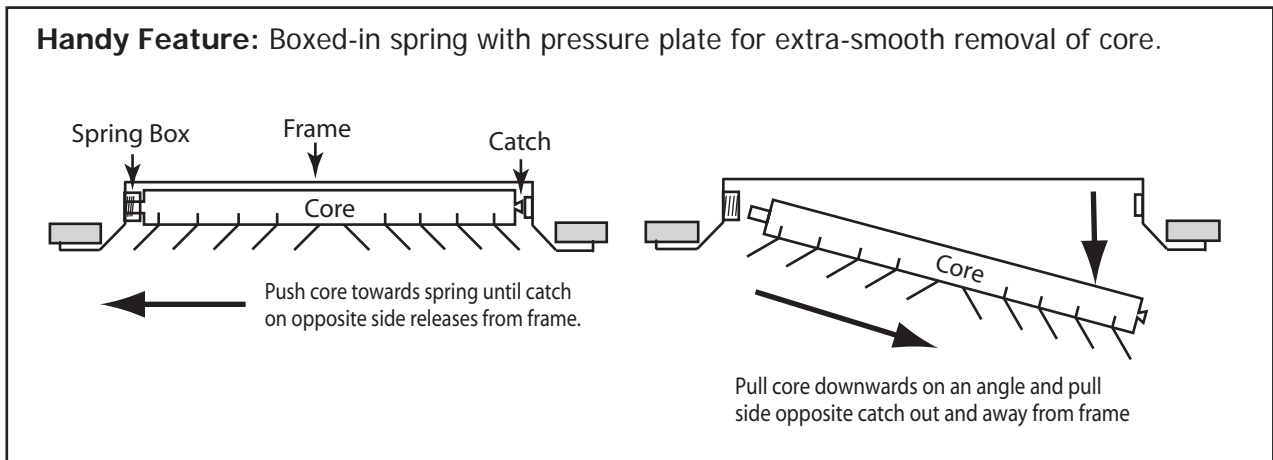
Core is removable to facilitate access to duct.



DLA

FEATURES

- Full Face 12"x12", 15"x15", 18"x18", 21"x21" and 24"x24"
- 1 Way, 2 Way Opposed, 2 Way Corner, 3 Way or 4 Way
- Commercial-grade aluminum construction
- Core can be easily removed without tools
- Ideal for VAV systems
- Powder paint coating - White



Directional Patterns									
W1	1 Way	WC	2 Way Corner	WO	2 Way Opposed	W3	3 Way	W4	4 Way

SERIES DLA, DLAM & DLAI

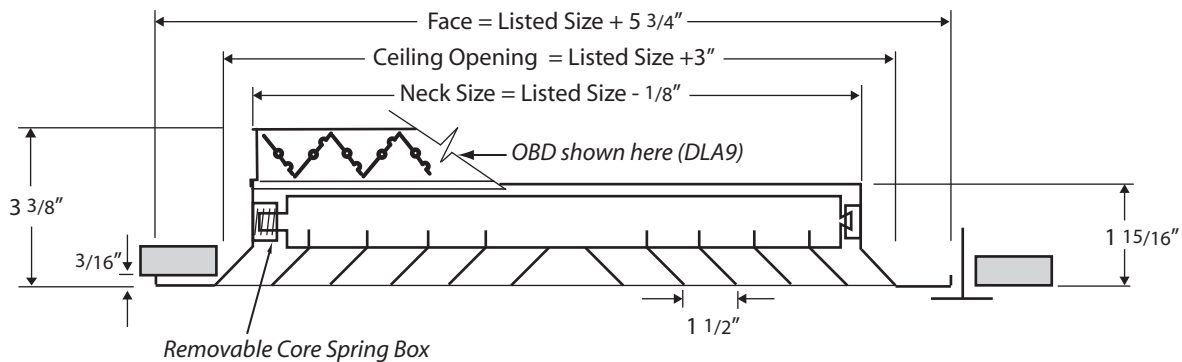


Border Types		Mounting		
F Flat Frame	B Beveled Frame	0 Lay-In	1 Screw Holes	4 Concealed
	 N/A for DLAI		 N/A for DLAI or Beveled Frame	 N/A for DLAI

MODEL SERIES DLA

MODEL DLA Square Neck

MODEL DLA9 Square Neck With Aluminum Opposed Blade Damper (N9)



HANDY FEATURE: One standard model suits both T-Bar and Drywall installations using rigid ducting.

HOW TO ORDER

DLA-F-0-W4 1818 /W

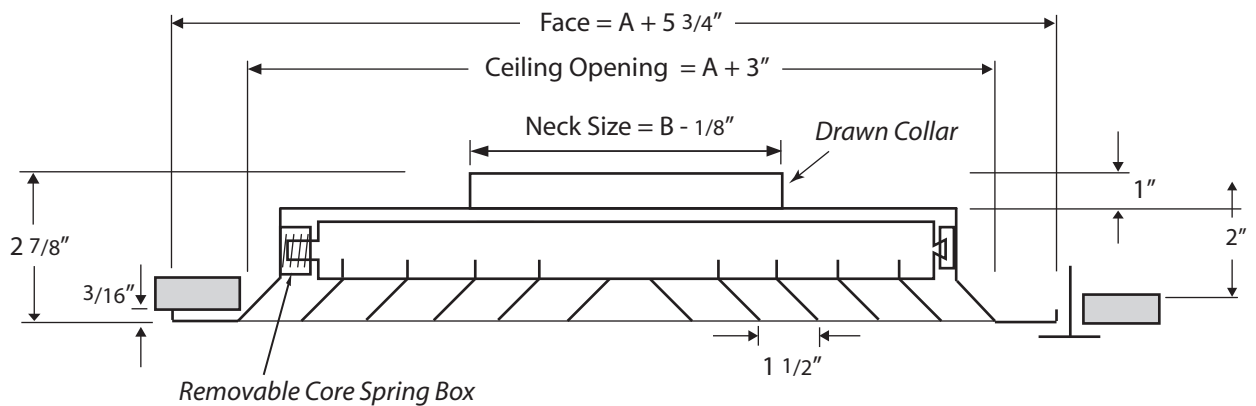
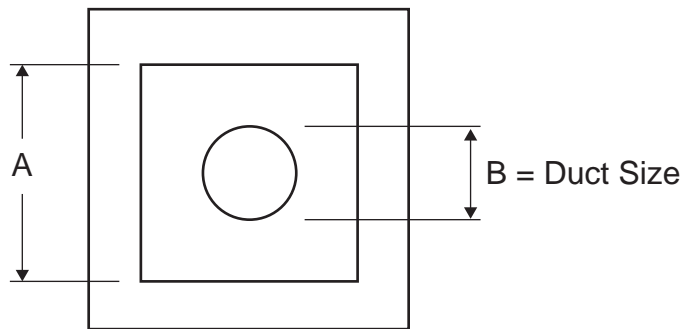
MODEL SERIES Square Neck DLA Square Neck w/ OBD DLA9	FINISH (OPTIONAL) Standard is White (/W) See chart for more
BORDER TYPE (OPTIONAL) Standard is flat frame Flat Frame -F Beveled Frame -B	DUCT DIMENSIONS 6" x 6" 0606 9" x 9" 0909 12" x 12" 1212 15" x 15" 1515 18" x 18" 1818
MOUNTING (OPTIONAL) Standard is Lay-In Lay-In -0 Screw Holes -1 Concealed -4	DIRECTION (OPTIONAL) Standard is 4 Way 1 Way -W1 2 Way Corner -WC 2 Way Opposed -WO 3 Way -W3 4 Way -W4

MODEL SERIES DLAM

MODEL DLAM Round Neck

MODEL DLAM4 Round Neck With Radial Opposed Blade Damper (N4)

MODEL DLAM5 Round Neck With Radial Sliding Blade Damper (N5)



HANDY FEATURE: One standard model suits both T-Bar and Drywall installations using rigid ducting.

HOW TO ORDER

DLAM-F-0-W4 1818 08 /W

MODEL SERIES

Round Neck, No Damper **DLAM**
 With N4 OBD **DLAM4**
 With N5 Radial Damper **DLAM5**

BORDER TYPE (OPTIONAL)

Standard is flat frame
 Flat Frame **-F**
 Beveled Frame **-B**

MOUNTING (OPTIONAL)

Standard is Lay-In
 Lay-In **-0**
 Screw Holes **-1**
 Concealed **-4**

DIRECTION (OPTIONAL)

Standard is 4 Way
 1 Way **-W1**
 2 Way Corner **-WC**
 2 Way Opposed **-WO**
 3 Way **-W3**

SQUARE NECK DIMENSIONS

6" x 6" **0606**
 9" x 9" **0909**
 12" x 12" **1212**
 15" x 15" **1515**
 18" x 18" **1818**

SQUARE TO ROUND NECK DIAMETER

6" **06**
 8" **08**
 10" **10**
 12" **12**
 14" **14**
 16" **16**

FINISH (OPTIONAL)

Standard is White (**/W**)
 See chart for more

Dampers Available



DLAM4 With Radial Opposed Blade Damper



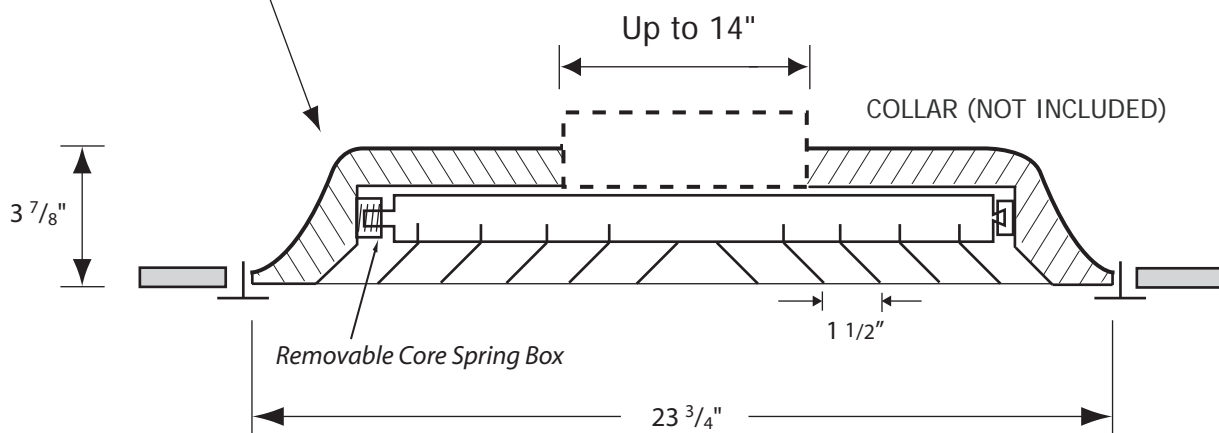
DLAM5 With Radial Sliding Blade Damper

MODEL SERIES DLAI

MODEL DLAI R6 Molded Fiberglass Insulated Back, Pre-Scored for Collars 6"-14"

R6 fiberglass back complies with A.S.T.M. E84 flame and smoke test.

Scored for collar sizes up to 14" D.
Contractor to install job-specific collar in field.



HOW TO ORDER

DLAI-W4 /W

MODEL SERIES
24"x24", R6 Insulated **DLAI**





















FINISH (OPTIONAL)
Standard is White (**/W**)
See chart for more

DIRECTION (OPTIONAL)

Standard is 4 Way

- 1 Way **-W1**
- 2 Way Corner **-WC**
- 2 Way Opposed **-WO**
- 3 Way **-W3**
- 4 Way **-W4**

TABLE 1 - PERFORMANCE DATA - SQUARE NECK

Duct Size Blow Pattern	Neck Velocity Velocity Press. Total Press.	300 .006 .030	400 .010 .051	500 .016 .080	600 .022 .118	700 .031 .160	800 .040 .210	900 .050 .260	
6" .25 SQ. FT.	Total CFM	75	100	125	150	175	200	225	
	NC	-	-	17	22	26	31	34	
		A B	A B	A B	A B	A B	A B	A B	
	 A	CFM/Side Throw (ft)	19 4-5-8	25 5-6-9	31 6-8-10	37 6-8-11	44 8-9-12	50 8-9-12	56 9-10-13
	 A	CFM/Side Throw (ft)	19 28 4-5-8 5-8-11	25 38 5-6-9 5-6-9	31 47 6-8-10 8-10-14	38 56 6-8-11 8-11-15	44 66 8-9-12 9-12-16	50 75 8-9-12 9-12-17	56 84 9-10-13 10-13-18
 A	CFM/Side Throw (ft)	38 8-9-12	50 9-10-14	62 10-11-16	75 11-12-17	88 12-13-18	100 12-14-19	113 13-15-22	
 A	CFM/Side Throw (ft)	75 9-11-15	100 10-12-17	125 11-14-19	150 12-15-22	175 13-16-22	200 14-17-24	225 15-18-25	
9" .56 SQ. FT.	Total CFM	170	225	280	340	395	450	505	
	NC	-	-	20	26	31	35	38	
		A B	A B	A B	A B	A B	A B	A B	
	 A	CFM/Side Throw (ft)	42 5-6-10	56 6-8-11	70 8-9-12	84 8-10-13	98 9-10-14	113 9-11-15	126 10-12-16
	 A	CFM/Side Throw (ft)	42 63 5-6-10 8-10-13	56 85 6-8-11 9-11-15	70 106 8-9-12 10-12-17	84 127 8-10-13 11-13-18	98 148 9-10-14 12-14-19	112 169 9-11-15 12-15-22	126 190 10-12-16 13-16-22
 A	CFM/Side Throw (ft)	84 9-10-15	112 11-13-18	141 12-15-20	169 13-16-22	197 14-17-23	225 15-18-25	253 16-19-28	
 A	CFM/Side Throw (ft)	169 12-15-20	225 14-17-23	282 16-19-26	338 17-22-29	394 18-22-31	450 19-24-33	507 22-25-35	
12" 1.0 SQ. FT.	Total CFM	300	400	500	600	700	800	900	
	NC	-	17	23	28	32	35	38	
		A B	A B	A B	A B	A B	A B	A B	
	 A	CFM/Side Throw (ft)	75 6-9-11	100 8-10-13	125 9-11-15	150 10-12-16	175 10-13-17	200 11-14-18	225 12-15-19
	 A	CFM/Side Throw (ft)	75 113 6-9-11 9-11-15	100 150 8-10-13 10-12-17	125 187 9-11-15 11-14-19	150 225 10-12-16 12-15-22	175 263 10-13-17 13-16-22	200 300 11-14-18 14-17-24	225 338 12-15-19 15-18-25
 A	CFM/Side Throw (ft)	150 11-13-18	200 13-15-22	250 15-17-24	300 16-18-26	350 17-19-28	400 18-22-30	450 19-22-32	
 A	CFM/Side Throw (ft)	300 14-17-24	400 16-19-28	500 18-22-32	600 19-23-34	700 22-25-36	800 23-27-38	900 24-29-41	
15" 1.56 SQ. FT.	Total CFM	465	625	780	935	1090	1250	1400	
	NC	-	19	25	29	33	37	41	
		A B	A B	A B	A B	A B	A B	A B	
	 A	CFM/Side Throw (ft)	117 8-10-13	156 9-11-15	195 10-12-17	234 11-13-18	273 12-14-19	313 12-15-22	351 13-16-24
	 A	CFM/Side Throw (ft)	117 176 8-10-13 11-13-18	156 234 9-11-15 13-15-22	195 292 10-12-17 15-17-24	234 352 11-13-18 16-18-26	273 410 12-14-19 17-19-28	313 469 12-15-22 18-22-30	351 527 13-16-24 19-22-32
 A	CFM/Side Throw (ft)	234 13-16-22	313 15-18-25	390 17-20-29	468 18-22-32	546 19-23-34	625 22-25-36	701 22-28-38	
 A	CFM/Side Throw (ft)	468 16-19-28	625 18-22-32	780 20-25-36	936 22-28-39	1092 23-30-42	1250 25-32-44	1405 28-34-47	
18" 2.25 SQ. FT.	Total CFM	675	900	1125	1350	1575	1800	2025	
	NC	12	20	27	31	35	39	42	
		A B	A B	A B	A B	A B	A B	A B	
	 A	CFM/Side Throw (ft)	168 9-11-15	225 10-12-17	281 11-14-19	337 12-15-21	394 13-16-22	450 14-17-24	506 15-18-25
	 A	CFM/Side Throw (ft)	168 253 9-11-15 12-15-20	225 338 10-12-17 9-11-15	281 422 11-14-19 16-19-26	338 506 12-15-21 17-22-29	394 591 13-16-22 18-22-31	450 675 14-17-24 19-24-33	506 758 15-18-25 22-25-35
 A	CFM/Side Throw (ft)	337 14-17-24	450 16-19-28	562 18-22-32	675 19-23-34	787 22-25-36	900 22-26-39	1013 24-29-41	
 A	CFM/Side Throw (ft)	675 17-22-30	900 20-24-34	1125 23-28-39	1350 24-30-41	1575 26-32-44	1800 29-35-47	2025 31-37-50	

Throw values for terminal velocities of
150 fpm, 100 fpm and 50 fpm

Neck Velocity (fpm)
Velocity Pressure (inches of water)
Total Pressure (inches of water)
NC Values based on 10 db room attenuation

TABLE 2 - PERFORMANCE CORRECTIONS SQUARE-TO-ROUND NECK











Square Inlet	Round Inlet	NC (add)	TP (multiply)	Throw (Multiply)		
				150	100	50
9" x 9"	6"	17	3.50	1.15	1.15	1.20
9" x 9"	8"	4	1.40	1.10	1.10	1.10
12" x 12"	8"	17	3.50	1.15	1.15	1.20
12" x 12"	10"	7	1.65	1.10	1.10	1.15
15" x 15"	10"	17	3.50	1.15	1.15	1.20
15" x 15"	12"	9	1.90	1.10	1.10	1.15
15" x 15"	14"	3	1.25	1.05	1.05	1.10
18" x 18"	12"	17	3.50	1.15	1.15	1.20
18" x 18"	14"	10	2.00	1.10	1.10	1.15
18" x 18"	16"	5	1.45	1.10	1.10	1.10

PERFORMANCE CORRECTIONS FOR RETURN AIR APPLICATIONS

Negative Static Pressure Add 10% to Total Pressure listed for supply.

Noise Criteria Add 1 to NC.

TABLE 1 - PERFORMANCE DATA - SQUARE NECK - INDUCTION VANES

Duct Size Blow Pattern	Neck Velocity Velocity Press. Total Press.	100		200		300		400		500		600		700		800		900		
		0.001 0.003		0.002 0.0012		0.006 0.030		0.010 0.051		0.016 0.080		0.022 0.118		0.031 0.160		0.040 0.210		0.050 0.260		
6" .25 SQ. FT.	Total CFM	25		50		75		100		125		150		175		200		225		
	NC	-		-		-		-		16		21		26		35		39		
		A	B	A	B	A	B	A	B	A	B	A	B	A	B	A	B	A	B	
		CFM/Side Throw (ft)	6.3 1-2-2		12.6 2-2-4		19 3-4-6		25 3-5-8		31 4-6-8		37 4-6-9		44 5-7-10		50 6-7-11		56 7-8-11	
		CFM/Side Throw (ft)	6 1-1-2	9 2-2-3	13 2-2-4	19 2-3-5	19 2-3-5	28 3-4-6	25 3-4-7	38 3-5-8	31 3-5-8	47 4-5-10	37 4-5-10	56 5-6-12	44 4-6-11	66 5-7-14	50 5-7-12	75 6-8-15	56 6-8-13	84 7-9-14
9" .56 SQ. FT.	Total CFM	56		112		170		225		280		340		395		450		505		
	NC	-		-		-		13		18		24		29		39		42		
		A	B	A	B	A	B	A	B	A	B	A	B	A	B	A	B	A	B	
		CFM/Side Throw (ft)	14 2-2-3		28 2-3-5		43 3-5-8		56 4-5-9		70 4-6-11		84 5-8-13		98 6-9-15		112 7-10-14		126 8-11-14	
		CFM/Side Throw (ft)	14 2-2-3	21 2-2-4	28 2-3-5	42 3-4-7	42 3-4-7	63 4-5-9	56 4-5-9	85 5-7-12	70 4-6-11	106 6-8-15	84 5-7-13	127 7-9-18	98 6-8-15	148 8-11-19	112 7-9-15	169 9-11-21	126 8-9-16	190 10-12-22
12" 1.0 SQ. FT.	Total CFM	100		200		300		400		500		600		700		800		900		
	NC	-		-		-		14		21		27		33		40		43		
		A	B	A	B	A	B	A	B	A	B	A	B	A	B	A	B	A	B	
		CFM/Side Throw (ft)	25 2-2-4		50 3-4-7		75 4-5-10		100 5-7-12		125 6-8-15		150 7-10-19		175 8-11-20		200 10-12-20		225 12-14-21	
		CFM/Side Throw (ft)	25 2-2-4	38 2-3-5	50 3-4-7	75 3-5-8	75 4-5-10	112 5-6-12	100 5-7-13	150 6-8-16	125 6-8-16	187 7-10-19	150 7-10-19	225 8-12-23	175 8-11-21	263 10-14-24	200 9-11-22	300 11-14-25	225 9-11-23	338 12-15-26
15" 1.56 SQ. FT.	Total CFM	156		315		465		625		780		935		1090		1250		1400		
	NC	14		23		14		23		29		34		37		43		45		
		A	B	A	B	A	B	A	B	A	B	A	B	A	B	A	B	A	B	
		CFM/Side Throw (ft)	39 2-3-5		78 3-5-8		117 4-6-12		156 6-8-16		195 7-10-19		234 8-13-22		273 9-14-25		312 11-16-26		350 13-18-32	
		CFM/Side Throw (ft)	39 2-3-5	59 3-3-6	78 3-5-8	117 4-6-10	117 4-6-12	175 6-8-15	156 6-8-15	234 7-10-20	195 7-10-19	292 9-13-24	234 8-12-23	351 10-15-23	273 9-11-26	409 12-17-34	312 10-12-26	468 13-18-34	350 11-14-27	527 14-19-35
18" 2.25 SQ. FT.	Total CFM	225		450		675		900		1125		1350		1575		1800		2025		
	NC	16		25		16		25		31		35		40		43		46		
		A	B	A	B	A	B	A	B	A	B	A	B	A	B	A	B	A	B	
		CFM/Side Throw (ft)	56 3-3-6		112 4-6-10		168 6-8-14		225 8-10-19		281 9-12-23		337 10-15-27		394 12-17-33		450 13-19-34		506 15-20-35	
		CFM/Side Throw (ft)	56 3-3-6	84 3-4-6	112 4-6-10	168 5-6-12	168 6-8-15	253 6-9-17	225 7-10-19	338 8-12-22	281 9-12-24	422 10-14-28	337 10-15-28	590 12-17-33	394 12-17-33	591 13-20-38	450 12-18-34	675 14-20-39	506 13-19-35	760 15-21-39

DATA SHEET

Throw values for terminal velocities of
150 fpm, 100 fpm and 50 fpm

Neck Velocity (fpm)
Velocity Pressure (inches of water)
Total Pressure (inches of water)
NC Values based on 10 db room attenuation

PERFORMANCE DATA

Nominal Size (inches)	Core Velocity (FPM) Vel. Press. (in w.g.) Total Press. (TP)	100	200	300	400	500	600	700
		CFM	25	50	75	100	125	150
Throw	1-2-2	2-2-4	2-3-5	3-5-7	3-6-7	4-6-10	4-7-12	
NC	-	-	-	-	16	21	26	
9 x 9	CFM	56	113	169	225	281	338	394
	Throw	1-2-3	2-3-5	3-5-7	4-5-9	4-6-11	5-8-13	6-9-16
NC	-	-	-	-	18	23	29	
12 x 12	CFM	100	200	300	400	500	600	700
	Throw	2-2-4	3-3-7	4-5-10	5-7-13	6-8-16	7-10-19	8-11-22
NC	-	-	-	13	20	27	32	
15 x 15	CFM	156	313	469	625	781	938	1094
	Throw	2-3-5	3-5-8	4-6-13	6-9-15	7-10-19	8-12-23	12-17-33
NC	-	-	-	16	22	29	34	
18 x 18	CFM	225	450	675	900	1125	1350	1575
	Throw	3-3-6	4-6-10	6-8-15	7-10-19	9-12-24	10-15-28	12-10-19
NC	-	-	-	16	23	30	35	

Performance Notes:

1. NC Value based on 10 dB room attenuation.
2. Throw values are based on isothermal air and terminal velocities of 150 fpm, 100 fpm and 50 fpm.
3. Above table applies for diffuser without OBD. For diffusers c/w OBD multiply by 1.20 the TP figure and add 4 to NC figure above.

 **NC > 30** Pressure values are in inches w.g.

ROUND DIFFUSERS



MODEL DRV MINI VALVE DIFFUSER

MODELDRV - Pressed Steel, Adjustable Core

DRV series valves are designed for the air supply or air exhaust in air conditioning, ventilation or heating installations.

Especially suitable for air exhaustion in washrooms and for ventilation installation in houses, apartments, offices, schools and hospitals.

It is mounted in walls or on duct. DRV series valves allow for high airflow pass obtaining good results in sound pressure performance. Flow is easily adjusted by turning the central Highlights

- Ideal for residential applications
- Rotate core clockwise or counter-clockwise to adjust airflow
- Better quality than plastic
- Comes with gasket to avoid air leaks

Neck Diameter	Supply		Return	
	Min cfm	Max cfm	Min cfm	Max cfm
4" (100 mm)	27	40	4	86
5" (125 mm)	40	62	10	127
6" (150 mm)	104	136	10	149
8" (200 mm)	168	252	19	302

ROUND NECK

Model	Duct Size	A	F	H	C	B	E
DRV 04	4"	4.09"	2.95"	1.57"	3.9"	4.92"	5.39"
DRV 05	5"	5.08"	3.9"	1.81"	4.88"	5.91"	6.46"
DRV 06	6"	6.65"	5.08"	2.13"	5.9"	6.91"	7.75"
DRV 08	8"	8.23"	6.18"	2.48"	7.83"	8.85"	9.76"

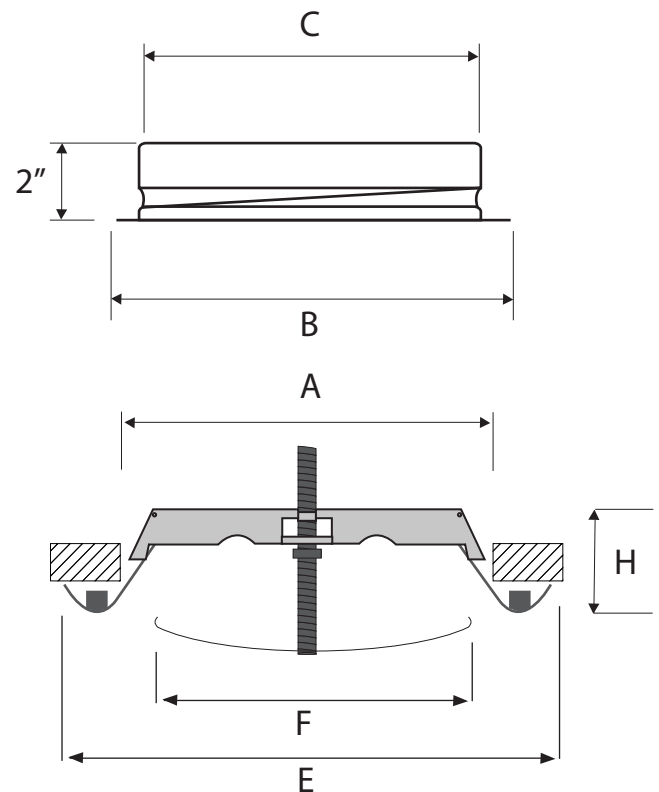
HOW TO ORDER DRV SERIES

DRV 04

Model series	Neck dimensions
Mini Valve Diffuser	04 4"
DRV	05 5"
	06 6"
	08 8"



DRV



SQUARE DIFFUSERS



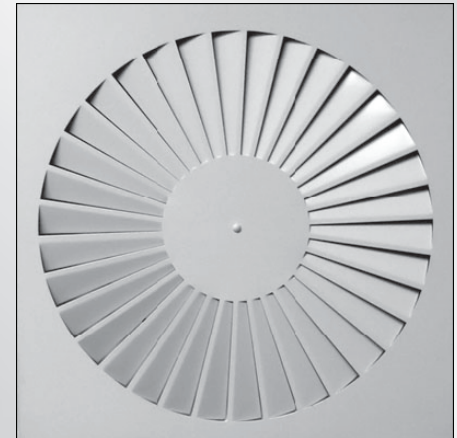
MODELS DSW, DSWI

MODEL **DSW** - Swirl Pattern, Round neck

MODEL **DSWI** - R6 Insulated, Pre-scored for collars

The **DSW Series** supply diffusers are high induction diffusers recommended for both heating and cooling in variable air volume systems.

The **DSW series** provide a 360° radial air diffusion pattern ideal for applications that require high induction rates for rapid temperature and velocity equalization of the mixed air mass above the zone of occupancy.



DSW

Features:

- Full face 24" x 24" for all neck sizes
- Optional 2" neck available for **DSW**
- Lay-in T-Bar ceiling mounting
- Heavy-gauge all-steel construction
- Ideal for VAV systems
- Powder paint coating - White (default) Custom colours avail.

Insulation:

DSW - Optional R4 or R6 insulation. R6 fiberglass insulation complies with A.S.T.M. E84 flame and smoke test. Only available on models with 24" x 24" face.
DSWI- R6 fibreglass insulation.

DSW Model #	Nominal Face Size	Actual Face Size B x B	Duct Size	Actual Neck Size
2406	24 x 24	23 ⁷ / ₈ x 23 ⁷ / ₈	6	5 ⁷ / ₈
2408	24 x 24	23 ⁷ / ₈ x 23 ⁷ / ₈	8	7 ⁷ / ₈
2410	24 x 24	23 ⁷ / ₈ x 23 ⁷ / ₈	10	9 ⁷ / ₈
2412	24 x 24	23 ⁷ / ₈ x 23 ⁷ / ₈	12	11 ⁷ / ₈
2414	24 x 24	23 ⁷ / ₈ x 23 ⁷ / ₈	14	13 ⁷ / ₈

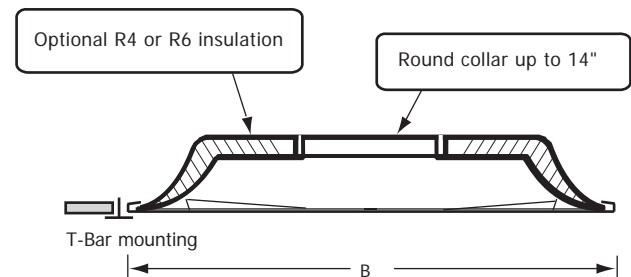
DSWI Model #	Nominal Face Size	Actual Face Size B x B
DSWI	24 x 24	23 ⁷ / ₈ x 23 ⁷ / ₈

All dimensions in inches

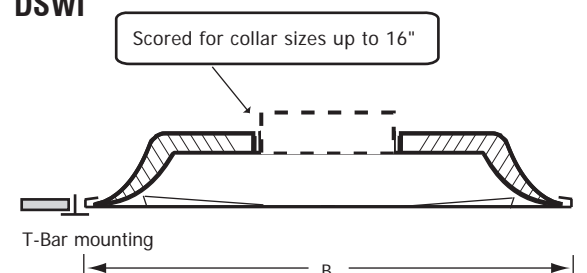


DSWI fiberglass back.

DSW



DSWI



ENGINEERING PERFORMANCE DATA

MODEL DSW

SQUARE PANEL



24" x 24" face

SIZE (inches)	Neck Velocity (fpm)	300	400	500	600	700	800	900	1000
	Velocity Pressure (in H ₂ O)	.006	.010	.016	.022	.031	.040	.050	.062
6"	CFM	59	79	98	118	137	157	177	196
	Total Pressure	.010	.018	.028	.040	.054	.071	.090	.111
	NC	-	-	-	-	-	18	21	24
	Throw (ft)	1-1-2	1-1-2	1-1-3	1-2-4	1-2-4	2-2-5	2-3-5	2-3-6
8"	CFM	105	140	174	209	244	279	314	349
	Total Pressure	.017	.030	.047	.068	.092	.120	.152	.188
	NC	-	-	-	-	19	23	26	29
	Throw (ft)	1-2-3	1-2-4	2-3-5	2-3-6	2-4-7	3-4-7	3-5-8	3-5-8
10"	CFM	164	218	273	327	382	436	491	545
	Total Pressure	.029	.051	.079	.114	.156	.203	.257	.318
	NC	-	15	22	27	31	35	38	41
	Throw (ft)	2-2-5	2-3-6	3-4-7	3-5-8	4-6-8	4-6-9	5-7-9	5-7-10
12"	CFM	236	314	393	471	550	628	707	785
	Total Pressure	.048	.086	.134	.194	.264	.344	.436	.538
	NC	17	24	31	36	40	44	47	50
	Throw (ft)	2-4-7	3-5-8	4-6-8	6-7-9	5-7-10	6-8-11	7-8-11	7-8-12
14"	CFM	321	428	535	641	748	855		
	Total Pressure	.082	.146	.228	.328	.446	.583		
	NC	24	32	38	43	47	51		
	Throw (ft)	3-5-8	4-6-9	5-7-10	6-8-11	7-8-12	7-9-12		
16"	CFM	419	558	698	837				
	Total Pressure	.139	.247	.385	.555				
	NC	30	38	44	49				
	Throw (ft)	4-6-9	6-7-13	6-8-11	7-9-12				

NC Value based on 10 db room attenuation.

Throw Values are based on isothermal air and terminal velocities of 150 fpm, 100 fpm, & 50 fpm respectively

Total Pressure the sum of static pressure plus velocity pressure and is given in inches w.g.

HOW TO ORDER DSW

DSW-R4-2-S-W3 2408 /W

MODEL SERIES
 Standard Plaque **DSW**
 Insulated Plaque **DSWI**

INSULATION (OPTIONAL)
 Standard is uninsulated
 R4.2 Taped Insulation **-R4**
 R6 Taped Insulation **-R6**

COLLAR HEIGHT (OPTIONAL)
 Standard is 1", no need to specify
 2" Fixed Collar **-2**

PACKAGING (OPTIONAL)
 Standard is 2 per box
 Single Box **-S**

FINISH (OPTIONAL)
 Standard is White **/W**
 See custom chart for more **/C**

NECK DIAMETER
06-08-10-12-14"

FACE DIMENSIONS
 24" x 24" **24**

DIRECTION (OPTIONAL)
 Standard is 4 Way -
 1 Way **-W1**
 2 Way Corner **-WC**
 2 Way Opposed **-WO**
 3 Way **-W3**

HOW TO ORDER DSWI

DSWI /W

MODEL SERIES
 Swirl Diffuser **DSWI**

FINISH (OPTIONAL)
 Standard is White **/W**
 See chart for more

CEILING RETURNS



EGGCRATE-ER SERIES

Series **ER** grilles and registers have grid cores capable of transferring or returning high air volumes with minimum air pressure loss. They match in appearance grid louvers on luminaires. Models **ERT** - **ERU** - **ERN** fit lay-in tee bar openings in suspended grid ceilings. Model **ERI** comes with fibreglass back panel and Model **ERM** comes with a steel back panel. Both **ERI** and **ERM** fit lay-in tee bar openings. Model **ERE** is the matching return grille. It fits overlap openings in solid ceilings and walls.

FEATURES

All Aluminium grilles

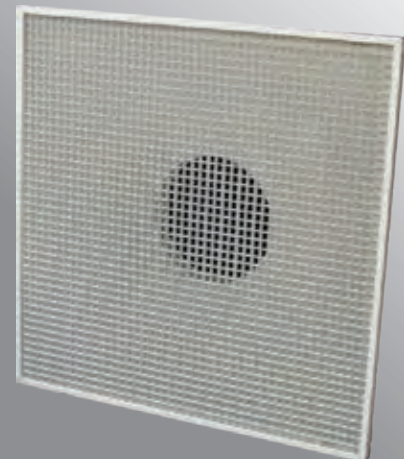
- Grid is $\frac{1}{2}'' \times \frac{1}{2}'' \times \frac{1}{2}''$.
- Frame is of extruded aluminium.
- Suitable for T-bar installations (Overall size = Listed size - $\frac{1}{4}''$).
 Model **ERT** (fig. 1) with $1\frac{1}{4}''$ wide "L" frame.
 Model **ERU** (fig. 2) with "U" frame.
 Model **ERN** (fig. 3) $\frac{1}{2}'' \times \frac{1}{2}'' \times \frac{1}{2}''$. Aluminium core only.
 Custom Sizing Available.
 Model **ERN1** (fig. 3) $\frac{1}{2}'' \times \frac{1}{2}'' \times 1''$. Model **ERN111** (fig. 3) $1'' \times 1'' \times 1''$. Aluminium core only. Fixed Sizes Only.
 Model **ERI** (fig. 4) aluminium core with molded fiberglass back and aluminium foil vapor barrier scored for 6" to 14" D.
 Model **ERM** (fig. 5) aluminium core with steel back panel.
- Suitable also for overlap installations, including drywall. (Collar size = Listed duct size - $\frac{1}{4}''$).
 Model **ERE** return grille (fig. 6) with $1\frac{1}{4}''$ wide margin has countersunk mounting screw holes as standard feature. (Screws are provided).
 Model **ERE** return grille is available with plaster frame (**ERE-F**) for use as plaster stop or as separate frame to facilitate grille removal.

Plastic grilles

- Model **ERN-P** (fig. 3) with plastic core.
- Grid is $\frac{1}{2}'' \times \frac{1}{2}'' \times \frac{3}{8}''$.
- Standard grille and panel sizes:
 $24'' \times 12''$ / $24'' \times 24''$ / $24'' \times 48''$.
 Other sizes are available in one piece up to $48'' \times 24''$.



ERT



ERM

Available Dimensions:
ERT, ERU, ERN, ERE

MIN. W X H	MAX. W X H
6" x 4"	Any even dimension up to 48" x 24"
2" increments of width and height.	
Multiple sections furnished for sizes greater than maximum width and height.	

DATA SHEET

ENGINEERING PERFORMANCE DATA

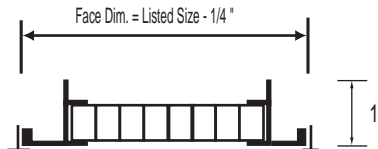
ER SERIES



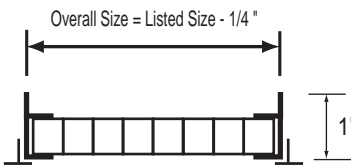
Installation Options

T-BAR INSTALLATIONS

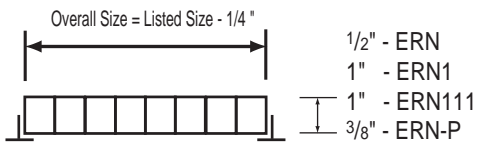
Model ERT
(With "L" frame)
Fig. 1



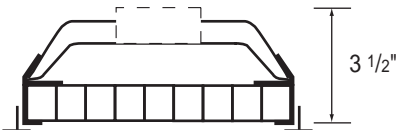
Model ERU
(with "U" frame)
Fig. 2



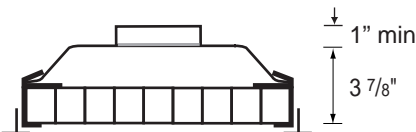
Model ERN, ERN1,
& ERN111 Aluminium
Model ERN-P Plastic
(Core only)
Fig. 3



Model ERI
(w/ fiberglass back panel)
Fig. 4

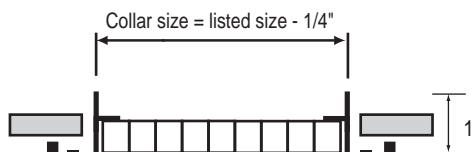


Model ERM
(w/ steel back panel)
Fig. 5



DRY WALL AND SURFACE MOUNT INSTALLATIONS

Model ERE (Return
Grille)
(Overlap frame)
Fig. 6



ENGINEERING PERFORMANCE DATA

ER SERIES

RETURN GRILLES AIRVECTOR®

		NC 20-25 Application Non-Ducted		NC 25-30 Application Ducted		NC 30-40 Application Ducted	
		Ps		Ps		Ps	
Listed Size W x H (inches)	Ak	-0.02"	-0.03"	-0.08"	-0.10"	-0.15"	-0.20"
		CFM	CFM	CFM	CFM	CFM	CFM
10 x 6	.42	140	170	280	315	385	445
12 x 6	.50	170	210	340	380	465	535
10 x 8	.53	195	240	390	440	535	615
12 x 8	.63	235	290	475	530	645	745
10 x 10	.64	245	305	500	560	685	790
18 x 6	.75	260	320	525	590	720	830
12 x 12	.89	370	455	745	835	1020	1170
18 x 12	1.3	575	710	1155	1295	1580	1820
22 x 10	1.4	630	775	1260	1410	1720	1980
24 x 12	1.7	770	945	1540	1725	2100	2420
18 x 18	1.9	890	1095	1785	2000	2440	2780
30 x 12	2.2	985	1210	1950	2180	2660	3060
24 x 18	2.5	1200	1470	2400	2690	3550	3770
36 x 12	2.7	1290	1590	2600	2910	3680	4100
22 x 22	2.8	1340	1650	2700	3020	3880	4240
30 x 18	3.2	1535	1890	3090	3450	4210	4850
24 x 24	3.3	1620	1990	3250	3640	4440	5125
36 x 18	3.8	1830	2250	3670	4110	5020	5775
30 x 24	4.1	2040	2510	4100	4590	5600	6450
34 x 22	4.3	2170	2670	4360	4875	5950	6860
36 x 24	4.9	2470	3040	4960	5550	7650	7775
36 x 30	6.1	3120	3840	6275	7040	8575	9900
34 x 34	6.3	3190	3930	6425	7200	8775	10100
48 x 24	6.6	3340	4100	6700	7500	9150	10500
48 x 30	8.1	4190	5150	8400	9400	11425	13150
48 x 36	9.7	5060	6240	10200	11400	13925	16100
46 x 46	11.6	6100	7475	12200	13700	16700	19300

HOW TO ORDER

EXAMPLE :

ERT 2412

T for T-bar with "L" frame

U for T-bar with "U" frame

N, N1, N111 for

Aluminium core only

N-P for Plastic core only

M for steel back panel

E for Drywall

E-F with plaster frame

I for R6 Insulated back

Listed
size

EGG CRATE FILTER GRILLES



MODELS ERMF-ERIF-ERTF FOR TEE BAR LAY-IN INSTALLATIONS

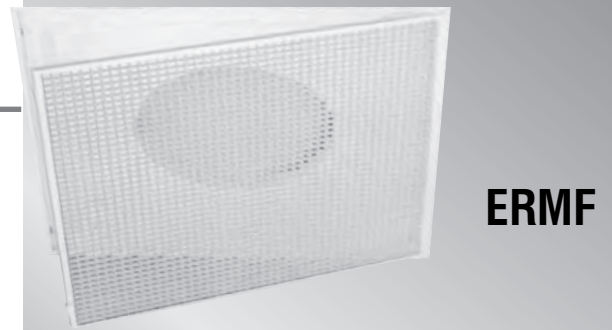
Series **ER** filter grilles have grid cores capable of transferring or returning high air volumes with minimum air pressure loss. They match in appearance grid louvers on luminaries.

The core consists of a 1/2" x 1/2" x 1/2" aluminum grid in a sturdy extruded aluminum U frame which swings in or out of the fixed back pan for easy access to the 1" standard filter or filter media (supplied by others). Two locking arms opposite to the two concealed hinges provide secure locking of the core in an unobtrusive manner.

Model **ERMF** has steel back pan with heavy gauge steel reinforcing corners equivalent to 18 ga. so as to minimize damage due to handling.

Model **ERIF** has an insulated back pan consisting of a fixed extruded aluminum frame and a molded fiberglass pan suitable for round duct connections up to 14" D. and scored for easy cutting of collar opening. This model has all aluminum metal components with sturdy corners so as to minimize damage due to handling .

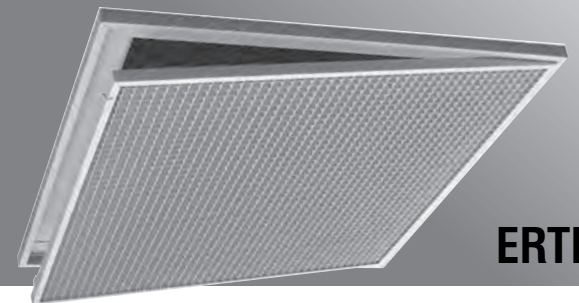
Model **ERTF** has a square filter frame to accomodate 20" x 20" filters and ducts of the same listed size. This model has sturdy corners so as to minimize damage due to handling.



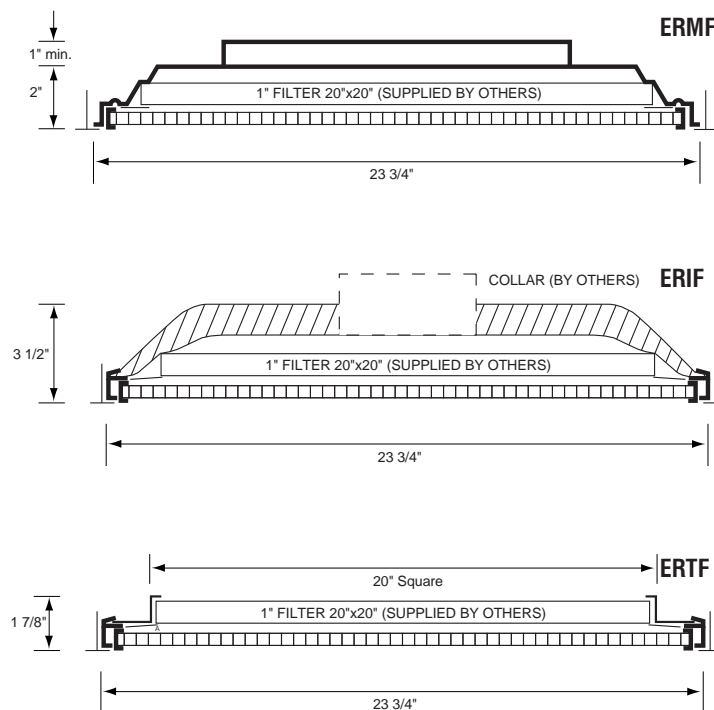
ERMF



ERIF



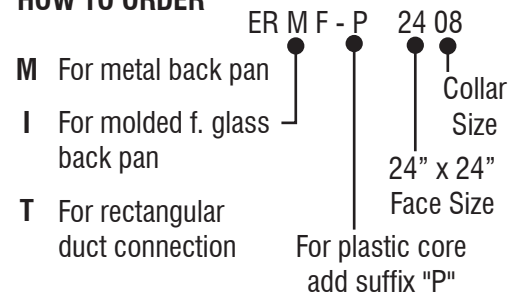
ERTF



PLASTIC EGG CRATES

All grilles are available with plastic core. Please specify by adding suffix "P". Example: ERMF-P, ERIF-P, ERTF-P etc. Plastic grid is 1/2" x 1/2" x 3/8".

HOW TO ORDER



Return Air Filter - Model FGAA40

Fixed Bar Type 45° Deflected Bars

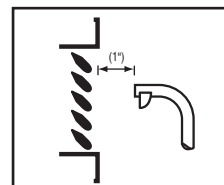
Listed Size W x H	A _K	NC 20-25 Application Non-Ducted		NC 25-30 Application Ducted		NC 30-40 Application Ducted	
		P _s		P _s		P _s	
		- .02"	- .03"	- .08"	- .10"	- .15"	- .20"
		CFM	CFM	CFM	CFM	CFM	CFM
10 x 6	.26	55	65	105	115	140	160
10 x 8	.34	75	90	145	160	195	225
12 x 8	.42	90	110	180	200	245	280
14 x 8	.50	110	135	220	245	300	345
12 x 10	.53	125	150	245	275	335	385
14 x 10	.63	155	190	310	345	420	485
12 x 12	.64	160	195	315	350	425	490
20 x 10	.75	170	205	335	375	455	525
14 x 14	.89	240	290	470	525	640	735
20 x 14	1.3	370	450	735	825	1005	1155
24 x 12	1.4	380	465	755	845	1030	1185
26 x 14	1.7	505	615	1000	1120	1365	1570
20 x 20	1.9	575	700	1140	1275	1555	1790
36 x 12	2.1	600	732	1195	1340	1635	1880
32 x 14	2.2	630	770	1255	1405	1715	1970
26 x 20	2.5	770	940	1530	1715	2090	2405
24 x 24	2.8	880	1075	1750	1960	2390	2750
32 x 20	3.2	970	1185	1930	2160	2635	3030
26 x 26	3.3	1040	1270	2070	2320	2830	3255
38 x 20	3.8	1170	1425	2320	2600	3170	3645
32 x 26	4.1	1320	1610	2625	2940	3585	4120
36 x 24	4.3	1355	1655	2695	3020	3685	4235
38 x 26	4.9	1580	1925	3135	3510	4280	4920
48 x 24	5.9	1940	2365	3855	4315	5265	6055
38 x 30	6.1	2010	2450	3995	4475	5460	6280
50 x 26	6.6	2130	2600	4240	4750	5795	6665
50 x 32	8.1	2700	3295	5370	6015	7340	8440
50 x 38	9.7	3220	3930	6405	7175	8755	10065

Performance of any size not shown in the tables will be the same as for the size shown with the same listed size area.

EXAMPLE:

A 38 x 18 size (not shown) has a listed area of 576 sq. in. Its performance will be identical to a 26 x 26 size (shown) which has the same listed size area of 576 sq. in.

AIR MEASUREMENT

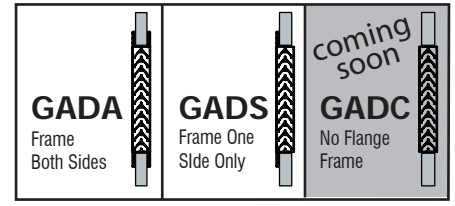


SYMBOLS P_s Static Pressure Inches H₂O
 A_K Outlet Area, 1" Out from Face
 NC Re 10 db Room attenuation

2220A Velometer Jet for V_K velocity measurement.
 CFM = A_K x V_K

PERFORMANCE DATA

Size (Inches)	Ak	Velocity (FPM)							
			200	300	400	500	600	700	800
8 x 8	.44	CFM	90	130	180	220	265	310	350
		PL	.08	.17	.30	.47	.68	.93	1.2
14 x 6	.55	CFM	110	165	220	275	330	385	440
		PL	.07	.16	.30	.46	.65	.90	1.2
12 x 8	.64	CFM	130	190	255	320	385	450	510
		PL	.07	.16	.29	.45	.64	.88	1.1
14 x 8	.74	CFM	150	220	295	370	445	520	590
		PL	.07	.16	.28	.44	.63	.87	1.1
20 x 6	.78	CFM	155	235	310	390	470	545	625
		PL	.07	.16	.28	.44	.62	.86	1.1
12 x 12	.93	CFM	185	280	370	465	560	650	745
		PL	.07	.15	.27	.43	.61	.84	1.1
30 x 6	1.12	CFM	225	335	450	560	670	785	895
		PL	.07	.15	.26	.42	.60	.82	1.1
16 x 12	1.19	CFM	240	360	475	595	715	835	950
		PL	.07	.15	.26	.41	.59	.81	1.1
18 x 12	1.33	CFM	265	400	530	665	800	930	1065
		PL	0.7	.15	.26	.41	.58	.88	1.0
20 x 12	1.46	CFM	290	440	585	730	875	1020	1170
		PL	.06	.15	.26	.40	.58	.79	1.0
16 x 16	1.54	CFM	310	460	615	770	925	1080	1230
		PL	.06	.14	.25	.40	.57	.78	1.0
24 x 12	1.75	CFM	350	525	700	875	1050	1225	1400
		PL	.06	.14	.25	.39	.56	.77	1.0
18 x 18	1.95	CFM	390	585	780	975	1170	1365	1560
		PL	.06	.14	.25	.39	.55	.76	.99
30 x 12	2.17	CFM	435	650	870	1085	1300	1520	1740
		PL	.06	.14	.25	.38	.54	.75	.98
20 x 20	2.42	CFM	485	730	970	1210	1450	1690	1940
		PL	.06	.14	.24	.38	.54	.74	.97
24 x 18	2.55	CFM	510	765	1020	1275	1530	1785	2040
		PL	.06	.14	.24	.37	.53	.73	.96
30 x 18	3.23	CFM	650	970	1290	1620	1940	2260	2580
		PL	.06	.13	.23	.36	.51	.71	.93
24 x 24	3.40	CFM	680	1020	1360	1700	2040	2380	2720
		PL	.06	.13	.23	.36	.51	.70	.92
30 x 24	4.18	CFM	840	1250	1670	2090	2510	2930	3340
		PL	.06	.13	.22	.35	.50	.68	.89
30 x 30	5.15	CFM	1030	1550	2580	3090	3610	3610	4120
		PL	.05	.12	.34	.48	.66	.66	.66



NOTE:
Ak: outlet area in Sq. feet.

ENGINEERING PERFORMANCE DATA

SUPPLY AIR GRILLES AND REGISTERS

Curved blade grilles - Series GCB10, GCB20, GCB30 & GCB40



TABLE 1

Nominal Duct Size	Face Vel. (fpm)	100	200	300	400	500	600	700	800	900	1000	
	Vel. Pressure	0.001	0.002	0.006	0.010	0.016	0.022	0.031	0.040	0.051	0.062	
	Tot. Pressure	0.003	0.014	0.031	0.056	0.090	0.131	0.175	0.225	0.290	0.355	
6x4	CFM				50	60	70	85	95	110	120	
	Throw	2-Way			5-8-13	7-9-12	8-12-19	9-13-18	10-15-21	12-17-24	13-19-31	
		1-Way			7-10-16	8-11-15	10-13-19	11-16-23	12-18-26	14-21-34	15-23-37	
	NC				14	20	24	28	32	35	38	
8x4	CFM			50	65	80	95	110	130	145	160	
	Throw	2-Way		5-7-11	6-9-14	7-11-17	9-13-21	10-14-20	11-16-23	12-18-26	14-21-33	
		1-Way		5-8-13	7-11-17	9-13-21	10-15-21	12-17-25	13-20-32	15-22-36	17-25-40	
	NC			<	15	21	26	30	33	36	39	
6x6 10x4	CFM			60	80	100	120	140	160	180	200	
	Throw	4-Way		4-6-9	5-8-13	6-9-15	8-11-18	9-13-21	1-14-20	11-16-23	12-17-25	
		3-Way		4-6-10	6-9-14	7-1-16	8-12-20	1-13-19	11-15-22	12-17-25	13-20-32	
		2-Way		5-7-11	6-9-15	8-11-18	9-14-22	1-15-21	12-17-25	13-20-32	15-22-35	
		1-Way		6-9-14	8-11-18	9-14-22	11-15-22	12-18-26	14-21-34	16-24-38	18-26-42	
NC			<	16	22	27	31	34	37	40		
8x6 12x4	CFM		50	80	105	130	155	180	210	235	260	
	Throw	4-Way		3-4-7	4-5-6	6-9-14	7-1-16	8-12-20	1-13-19	11-15-22	12-17-25	13-20-32
		3-Way		3-4-7	5-6-7	6-9-15	8-11-18	9-13-21	1-14-20	11-16-23	13-19-31	14-21-34
		2-Way		3-5-8	5-6-8	7-9-12	8-12-20	1-14-20	11-16-23	13-19-31	14-21-34	16-24-38
		1-Way		4-5-6	6-8-11	8-11-15	1-14-20	12-17-24	13-20-32	15-23-37	17-26-41	19-28-45
NC		<	10	17	23	28	32	35	38	41		
14x4	CFM		60	90	120	150	180	210	240	270	300	
	Throw	4-Way		3-4-7	4-5-6	6/8/10	7/10/13	9/12/17	10/14/20	11/16/23	12/18/26	14-21-33
		3-Way		3-5-8	5-6-7	6/9/15	8/11/15	9/13/18	10/15/21	12/17/25	13-20-32	15-22-35
		2-Way		3-5-8	5-7-9	7/10/13	9/12/17	10/14/20	12/17/24	13-20-32	16-24-38	16-24-39
		1-Way		4-5-6	6/8/11	8/11/16	10/15/21	12/17/25	14-21-34	16-24-38	18-27-43	20-29-47
NC		<	10	18	23	28	32	36	39	42		
8x8 10x6 16x4	CFM		70	105	140	175	210	245	280	315	350	
	Throw	4-Way		3-4-7	5-7-11	6-9-15	8-11-18	9-13-21	1-15-21	12-17-24	13-19-31	14-21-34
		3-Way		3-5-8	5-7-12	6-9-15	8-12-19	1-13-19	11-15-22	14-19-30	14-21-33	15-23-37
		2-Way		4-6-9	5-8-13	7-1-13	9-13-21	1-15-21	12-17-25	14-21-33	15-23-37	17-26-41
		1-Way		4-5-6	7-9-12	9-12-17	1-15-21	12-18-26	15-22-35	17-25-40	18-27-44	20-31-49
NC		<	11	18	24	29	33	37	39	42		
12x6 18x4	CFM		80	120	160	200	240	280	320	360	400	
	Throw	4-Way		3-5-8	5-6-7	6-8-11	8-11-15	9-13-18	11-15-22	12-17-25	13-20-32	15-22-35
		3-Way		3-5-8	5-6-8	7-9-12	8-11-16	1-14-20	11-16-20	13-19-31	15-22-35	16-24-38
		2-Way		4-6-9	6-8-10	8-1-14	9-13-18	11-15-22	12-18-26	14-21-34	16-24-38	18-26-42
		1-Way		5-6-7	7-9-12	9-13-18	11-15-22	13-19-31	15-22-36	17-26-41	19-29-46	21-32-51
NC			12	19	25	30	34	37	40	43		
10x8 14x6	CFM		90	135	180	225	270	315	360	405	450	
	Throw	4-Way		3-5-8	5-6-8	6-9-15	8-12-19	1-13-19	11-15-22	12-18-26	14-21-33	15-23-37
		3-Way		3-5-8	5-7-9	7-11-17	9-13-21	1-14-20	12-17-24	13-20-32	15-22-36	16-24-39
		2-Way		4-6-9	6-8-10	8-12-19	1-13-19	11-16-23	13-19-31	15-22-35	16-24-39	18-27-44
		1-Way		5-7-11	7-11-17	9-14-22	11-16-23	13-20-32	15-23-37	18-26-42	20-29-47	22-33-53
NC		<	12	19	26	30	34	38	41	44		
12x8 16x6 24x4	CFM		55	110	165	220	275	330	385	440	495	
	Throw	4-Way	2-3-4	3-5-8	5-7-12	7-1-16	8-12-20	1-14-20	12-17-24	13-19-31	15-22-35	16-24-39
		3-Way	2-3-5	4-6-9	5-8-13	8-11-18	9-14-22	11-15-22	12-18-26	14-21-33	16-24-38	17-26-41
		2-Way	2-3-5	4-6-10	6-9-15	8-12-20	1-14-20	12-17-25	14-21-33	15-23-37	17-26-41	19-29-46
		1-Way	2-4-6	5-7-12	8-11-18	1-13-19	12-17-25	14-21-34	16-24-39	18-27-44	21-31-50	23-35-56
NC		<	<	13	20	26	31	35	39	41	44	
10x10 18x6	CFM		60	125	185	250	310	370	435	495	620	
	Throw	4-Way	2-3-4	4-6-9	5-8-13	7-11-17	9-13-21	1-15-21	12-17-24	13-20-32	15-22-36	17-25-40
		3-Way	2-3-5	4-6-9	6-9-14	8-11-18	9-14-22	11-16-23	13-19-31	14-21-34	16-24-39	18-27-43
		2-Way	2-3-5	4-6-10	6-9-15	8-12-20	1-16-25	12-17-25	14-21-34	16-24-38	18-27-43	20-29-47
		1-Way	2-3-6	5-7-12	8-11-18	1-14-20	12-19-30	15-22-35	17-26-41	19-29-46	21-32-51	24-36-57
NC		<	<	13	21	27	32	36	39	42	45	

ENGINEERING PERFORMANCE DATA

SUPPLY AIR GRILLES AND REGISTERS Curved blade grilles - Series GCB10, GCB20, GCB30 & GCB40



Nominal Duct Size	Face Vel. (fpm)	100	200	300	400	500	600	700	800	900	1000	
	Vel. Pressure	0.001	0.002	0.006	0.010	0.016	0.022	0.031	0.040	0.051	0.062	
	Tot. Pressure	0.003	0.014	0.031	0.056	0.090	0.131	0.175	0.225	0.290	0.355	
30x4 20x6 14x8 12x10	CFM	70	140	210	280	350	420	490	550	630	700	
	Throw	4-Way	2-3-5	4-6-9	5-8-13	7-11-17	9-13-21	10/15/21	12-17-25	14-21-33	15-23-37	17-26-41
		3-Way	2-3-5	4-6-9	6-9-14	8-12-19	10/13/19	11-16-23	13-20-32	15-22-36	17-25-40	18-27-44
		2-Way	2-4-6	5-7-11	7/10/16	9-13-21	10/15/21	12/18/26	15-22-35	17-25-40	18-27-44	20-31-49
		1-Way	3-4-7	5-8-13	8-12-19	10/15/21	12-19-30	15-22-36	18-26-42	20-29-47	22-33-53	25-37-59
NC	-	-	14	21	27	32	36	40	42	45		
36x4 24x6 16x8 14x10	CFM	80	160	245	325	405	485	565	650	730	810	
	Throw	4-Way	2-3-5	4-6-9	6-9-14	8-11-18	9-14-22	11-15-22	12-18-26	14-21-34	16-24-38	18-27-43
		5-Way	2-3-5	4-6-10	6-9-15	8-12-20	11-15-22	12-17-24	14-21-33	15-23-37	17-26-41	19-29-46
		2-Way	2-4-6	5-7-11	7-1-16	9-14-22	11-15-22	13-19-31	15-22-36	17-26-41	19-29-46	21-32-51
		1-Way	3-4-7	5-8-13	8-12-20	11-15-22	13-20-32	16-24-38	18-27-44	20-31-49	23-34-55	26-39-62
NC	-	-	15	22	28	33	37	40	43	46		
24x8 18x15 16x12	CFM	85	175	260	350	435	520	610	695	785	870	
	Throw	4-Way	2-3-5	4-6-9	6-9-14	8-12-19	1-13-19	11-16-23	13-19-31	15-22-35	16-24-39	18-27-43
		3-Way	2-3-5	4-6-10	6-9-15	8-12-20	1-15-21	12-17-25	14-21-33	16-24-38	18-26-42	20-29-47
		2-Way	2-4-6	5-7-11	7-11-17	9-14-22	11-16-23	13-20-32	15-23-37	18-26-42	20-29-47	22-32-52
		1-Way	3-4-7	6-9-14	8-12-20	11-15-22	13-20-32	16-24-39	19-28-45	21-31-50	13-35-56	26-39-63
NC	-	-	15	22	28	33	37	40	43	46		
30x6 20x8 16x10 14x12	CFM	100	205	305	410	510	610	715	815	920	1020	
	Throw	4-Way	2-3-5	4-6-10	6-9-15	8-12-19	1-14-20	12-17-24	13-20-32	15-22-36	17-26-41	19-28-45
		5-Way	2-4-6	4-6-10	7-1-16	9-13-21	1-16-25	12-18-26	15-22-35	16-24-39	18-27-44	20-30-48
		2-Way	2-4-6	5-7-12	7-11-17	1-13-19	12-17-24	14-21-33	16-24-39	18-27-43	20-31-49	23-34-55
		1-Way	3-4-7	6-9-14	9-13-21	11-17-27	14-21-34	17-25-40	19-29-46	22-32-52	25-37-59	27-41-65
NC	-	-	16	23	29	34	38	41	44	47		
24x8 18x10 16x12	CFM	115	230	345	460	575	690	805	920	1040	1150	
	Throw	4-Way	2-3-5	4-6-10	5-9-15	8-12-20	1-15-21	12-17-25	14-21-33	16-24-38	18-26-42	19-29-46
		3-Way	2-4-6	5-7-11	7-1-16	9-13-21	11-15-22	13-19-31	15-22-36	17-26-41	19-28-45	21-31-50
		2-Way	2-4-6	5-7-12	8-11-18	1-13-19	12-17-25	14-21-34	17-25-40	19-28-45	21-31-50	23-35-56
		1-Way	3-5-8	6-9-15	9-14-22	12-17-24	15-22-35	17-26-41	20-29-47	22-34-54	25-27-60	28-42-68
NC	-	-	16	24	30	34	38	42	45	48		
36x6 20x10 14x14	CFM	125	250	375	500	625	750	875	1000	1120	1250	
	Throw	4-Way	2-3-5	4-5-6	6-8-11	8-12-20	1-15-21	12-17-25	14-21-34	16-24-38	18-27-43	20-29-47
		3-Way	2-4-6	5-6-7	7-9-12	9-14-22	11-16-23	13-20-32	15-23-37	17-26-41	19-29-46	21-32-51
		2-Way	2-4-6	5-6-8	8-1-14	1-14-20	12-18-26	15-22-35	17-26-41	19-29-46	21-32-51	24-36-57
		1-Way	3-5-8	6-8-11	9-13-18	12-17-25	15-22-35	18-26-42	20-30-48	23-34-55	26-39-62	29-43-69
NC	-	-	16	24	30	35	39	42	45	48		
16x14 18x12	CFM	135	270	405	540	675	810	945	1080	1220	1350	
	Throw	4-Way	2-4-6	4-5-6	7-1-16	9-13-21	1-15-21	12-18-26	15-22-35	16-24-39	18-27-43	20-30-48
		3-Way	2-4-6	5-6-7	7-11-17	9-14-22	11-16-23	13-20-32	15-23-37	18-26-42	20-29-47	22-32-52
		2-Way	3-4-7	5-7-9	8-12-19	1-15-21	12-18-26	15-22-36	18-26-42	20-29-47	22-33-53	25-37-59
		1-Way	3-5-8	6-8-11	10-13-19	12-17-25	15-22-36	18-27-43	21-31-50	23-35-56	26-39-63	29-44-70
NC	-	-	17	24	30	35	39	42	45	48		
30x8 24x10 20x12 18x14 16x6	CFM	155	305	460	610	765	920	1070	1220	1380	1530	
	Throw	4-Way	2-4-6	5-6-7	7-1-16	9-13-21	11-15-22	13-19-31	15-22-36	17-25-40	19-28-45	21-31-50
		3-Way	2-4-6	5-6-8	7-11-17	10-13-19	12-17-24	14-21-33	16-24-39	18-27-44	20-31-49	22-34-54
		2-Way	3-4-7	5-7-9	8-12-19	10-15-21	13-20-32	15-23-37	18-27-43	20-30-48	23-34-55	25-37-60
		1-Way	3-5-8	7-9-12	10-13-19	12-18-26	15-23-37	18-27-44	21-32-51	24-36-58	27-41-65	30-46-73
NC	-	-	17	25	31	36	40	43	46	49		
36x8 30x10 24x12 20x14 18x16	CFM	182	365	545	730	910	1090	1270	1460	1640	1820	
	Throw	4-Way	2-4-6	5-6-7	7-11-17	9-14-22	11-16-23	13-20-32	15-23-37	18-26-42	20-29-47	22-33-53
		3-Way	2-4-6	5-6-8	8-11-18	10-14-20	12-17-25	15-22-35	17-25-40	19-28-45	21-32-51	24-36-57
		2-Way	3-4-7	6-8-10	8-12-20	11-16-23	14-21-33	16-24-39	19-28-45	21-31-50	24-36-57	26-39-63
		1-Way	3-5-8	7-9-12	10-14-20	13-20-32	16-24-39	19-29-46	22-34-54	25-37-60	29-42-68	32-48-76
NC	-	-	18	26	32	36	40	44	47	50		
24x14 20x16 18x18	CFM	210	420	630	840	1050	1260	1470	1680	1890	2100	
	Throw	4-Way	2-4-6	5-6-8	8-11-18	10-13-19	12-17-24	14-21-34	16-24-29	18-27-44	20-31-49	23-34-55
		3-Way	3-4-7	5-7-9	8-12-19	10-15-21	12-18-26	15-22-36	18-26-42	20-29-47	22-33-53	25-37-59
		2-Way	3-4-7	6-8-10	9-13-21	12-17-24	14-21-34	17-25-40	19-29-46	22-32-52	25-37-59	28-41-66
		1-Way	4-6-9	7-10-13	10-15-21	14-21-33	17-25-40	20-30-48	23-34-55	25-39-62	29-44-70	33-50-80
NC	-	-	19	26	32	37	41	44	47	50		

GRILLES



ALUMINUM

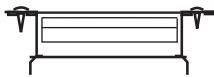
MODELS

- GDA1 supply, single deflection spiral duct grille
- GDA2 supply, double deflection spiral duct grille



Fastening Methods

Air Scoop: For grilles with air scoop, add suffix 8



Screw holes

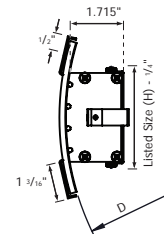
Single deflection supply spiral duct grilles are recommended for applications requiring pattern adjustability in a horizontal plane.

Double-deflection supply spiral duct grilles are recommended for application in systems requiring optimum flexibility of pattern changes to accommodate changing job conditions.

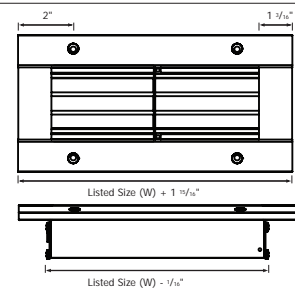
The combination of streamlined foil shaped bars and 17 mm (2/3 inch) bar spacing maintains a high effective area capacity of greater than 80% which minimizes outlet velocity, reduces pressure drop and assures quiet operation. Individually adjustable bars are capable of shortening throw up to one-half with a wide spread deflection requiring only a 20% increase in outlet velocity at a fixed volume.

GDA Series have extruded aluminum frames and bars which follow the curve on the face of the grille.

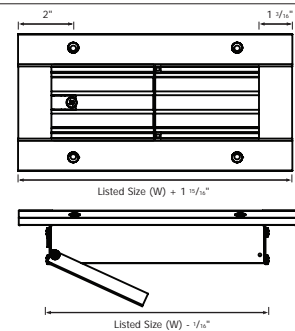
Dimensions



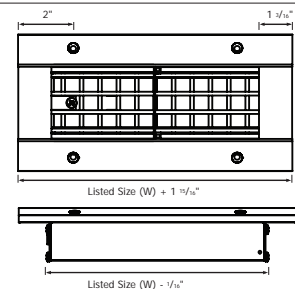
GDA10



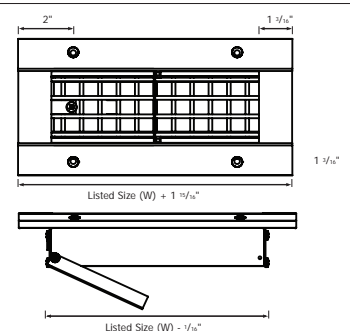
GDA18



GDA20



GDA28



HOW TO ORDER GDA SERIES

GDA28-D14 1006 /W

<p>MODEL SERIES Alum Spiral Duct Grille GDA</p> <p>AIR PATTERN Single Deflection 1 Double Deflection 2</p> <p>GRILLE/AIR SCOOP Grille Only 0 Grille with Air Scoop 8</p>	<p>HEIGHT (INCHES) 14</p> <p>WIDTH (INCHES) 10</p> <p>DUCT DIMENSION Duct Diameter -D##</p> <p>Finish White (Default) /W</p>
--	---

MAX. LISTED SIZE: 36"x12"
FINISH: Powder baked enamel paint for durability. Default is White. Other finishes available (see chart for more).

DATA SHEET

ENGINEERING PERFORMANCE DATA

SPIRAL DUCT GRILLES

Single and Double Deflection Adjustable - GDA Series



TABLE 1

LISTED HEIGHT				Outlet Velocity 450-600 FPM				Outlet Velocity 550-700 FPM				Outlet Velocity 600-800 FPM				Outlet Velocity 700-1000 FPM																																																																																																																																																																																																																																																																																																																																																																																																																																																																																																																																																																																																																																																																																																																																																																																																																																																																																																																																																																																																																																																																																																																																																																																																																																					
				CFM				Deflection				Deflection				Deflection				Deflection																																																																																																																																																																																																																																																																																																																																																																																																																																																																																																																																																																																																																																																																																																																																																																																																																																																																																																																																																																																																																																																																																																																																																																																																																																	
								0°	22°	42°	55°	0°	22°	42°	55°	0°	22°	42°	55°	0°	22°	42°	55°																																																																																																																																																																																																																																																																																																																																																																																																																																																																																																																																																																																																																																																																																																																																																																																																																																																																																																																																																																																																																																																																																																																																																																																																																														
				CFM				V _K				V _K				V _K				V _K																																																																																																																																																																																																																																																																																																																																																																																																																																																																																																																																																																																																																																																																																																																																																																																																																																																																																																																																																																																																																																																																																																																																																																																																																																	
								450	500	550	600	550	600	650	700	600	700	750	800	700	800	900	1000																																																																																																																																																																																																																																																																																																																																																																																																																																																																																																																																																																																																																																																																																																																																																																																																																																																																																																																																																																																																																																																																																																																																																																																																																														
CFM				P _T				P _T				P _T				P _T																																																																																																																																																																																																																																																																																																																																																																																																																																																																																																																																																																																																																																																																																																																																																																																																																																																																																																																																																																																																																																																																																																																																																																																																																																					
				.01	.01	.02	.02	.02	.02	.03	.03	.02	.03	.04	.04	.03	.04	.05	.06																																																																																																																																																																																																																																																																																																																																																																																																																																																																																																																																																																																																																																																																																																																																																																																																																																																																																																																																																																																																																																																																																																																																																																																																																																		
CFM				Throw (T) V _T 75				Throw (T) V _T 75				Throw (T) V _T 75				Throw (T) V _T 75																																																																																																																																																																																																																																																																																																																																																																																																																																																																																																																																																																																																																																																																																																																																																																																																																																																																																																																																																																																																																																																																																																																																																																																																																																					
				CFM				CFM				CFM				CFM																																																																																																																																																																																																																																																																																																																																																																																																																																																																																																																																																																																																																																																																																																																																																																																																																																																																																																																																																																																																																																																																																																																																																																																																																																					
4	5	6	8	10	12	14	16	18	20	24	4	5	6	8	10	12	14	16	18	20	24	4	5	6	8	10	12	14	16	18	20	24	4	5	6	8	10	12	14	16	18	20	24																																																																																																																																																																																																																																																																																																																																																																																																																																																																																																																																																																																																																																																																																																																																																																																																																																																																																																																																																																																																																																																																																																																																																																																																										
6	5										40	6	5	4	3	45	8	7	6	4	60	10	9	7	5	65	11	10	8	6	70	11	10	8	6	75	12	11	9	7	80	12	11	9	7	85	13	12	10	8	90	10	9	7	6	100	12	11	9	7	125	13	12	10	8	150	15	14	11	9	175	17	16	13	10	200	19	18	14	11	225	21	20	15	12	250	23	22	16	13	275	25	24	17	14	300	27	26	18	14	350	29	28	19	15	425	33	32	22	17	475	37	36	24	18	500	40	39	25	19	550	42	41	26	20	625	44	43	27	21	700	45	44	27	21	750	46	45	28	22	850	48	47	29	22	975	50	49	30	23	1125	52	51	31	24	1250	54	53	32	25	1400	57	56	33	26	1600	60	59	34	27	1800	63	62	35	28	2100	67	66	37	30	2450	71	70	39	32	2800	75	74	41	34	3200	79	78	43	36	3600	83	82	45	38	4000	87	86	47	40	4800	91	90	49	42																																																																																																																																																																																																																																																																																																																																																																																																																																																																																																																																																																																																																																																																																																																																																																																																																																																																																																																																																																																																																																			
12	10	8									100	10	8	6	5	125	11	9	8	7	150	13	12	9	8	175	14	13	10	8	200	15	14	11	9	225	16	15	11	9	250	17	16	12	10	275	18	17	12	10	300	19	18	13	10	325	20	19	13	11	350	21	20	14	11	375	22	21	14	11	400	23	22	14	11	425	24	23	14	11	450	25	24	14	11	475	26	25	14	11	500	27	26	14	11	525	28	27	14	11	550	29	28	14	11	575	30	29	14	11	600	31	30	14	11	625	32	31	14	11	650	33	32	14	11	675	34	33	14	11	700	35	34	14	11	725	36	35	14	11	750	37	36	14	11	775	38	37	14	11	800	39	38	14	11	825	40	39	14	11	850	41	40	14	11	875	42	41	14	11	900	43	42	14	11	925	44	43	14	11	950	45	44	14	11	975	46	45	14	11	1000	47	46	14	11	1025	48	47	14	11	1050	49	48	14	11	1075	50	49	14	11	1100	51	50	14	11	1125	52	51	14	11	1150	53	52	14	11	1175	54	53	14	11	1200	55	54	14	11	1225	56	55	14	11	1250	57	56	14	11	1275	58	57	14	11	1300	59	58	14	11	1325	60	59	14	11	1350	61	60	14	11	1375	62	61	14	11	1400	63	62	14	11	1425	64	63	14	11	1450	65	64	14	11	1475	66	65	14	11	1500	67	66	14	11	1525	68	67	14	11	1550	69	68	14	11	1575	70	69	14	11	1600	71	70	14	11	1625	72	71	14	11	1650	73	72	14	11	1675	74	73	14	11	1700	75	74	14	11	1725	76	75	14	11	1750	77	76	14	11	1775	78	77	14	11	1800	79	78	14	11	1825	80	79	14	11	1850	81	80	14	11	1875	82	81	14	11	1900	83	82	14	11	1925	84	83	14	11	1950	85	84	14	11	1975	86	85	14	11	2000	87	86	14	11	2025	88	87	14	11	2050	89	88	14	11	2075	90	89	14	11	2100	91	90	14	11	2125	92	91	14	11	2150	93	92	14	11	2175	94	93	14	11	2200	95	94	14	11	2225	96	95	14	11	2250	97	96	14	11	2275	98	97	14	11	2300	99	98	14	11	2325	100	99	14	11	2350	101	100	14	11	2375	102	101	14	11	2400	103	102	14	11	2425	104	103	14	11	2450	105	104	14	11	2475	106	105	14	11	2500	107	106	14	11	2525	108	107	14	11	2550	109	108	14	11	2575	110	109	14	11	2600	111	110	14	11	2625	112	111	14	11	2650	113	112	14	11	2675	114	113	14	11	2700	115	114	14	11	2725	116	115	14	11	2750	117	116	14	11	2775	118	117	14	11	2800	119	118	14	11	2825	120	119	14	11	2850	121	120	14	11	2875	122	121	14	11	2900	123	122	14	11	2925	124	123	14	11	2950	125	124	14	11	2975	126	125	14	11	3000	127	126	14	11	3025	128	127	14	11	3050	129	128	14	11	3075	130	129	14	11	3100	131	130	14	11	3125	132	131	14	11	3150	133	132	14	11	3175	134	133	14	11	3200	135	134	14	11	3225	136	135	14	11	3250	137	136	14	11	3275	138	137	14	11	3300	139	138	14	11	3325	140	139	14	11	3350	141	140	14	11	3375	142	141	14	11	3400	143	142	14	11	3425	144	143	14	11	3450	145	144	14	11	3475	146	145	14	11	3500	147	146	14	11	3525	148	147	14	11	3550	149	148	14	11	3575	150	149	14	11	3600	151	150	14	11	3625	152	151	14	11	3650	153	152	14	11	3675	154	153	14	11	3700	155	154	14	11	3725	156	155	14	11	3750	157	156	14	11	3775	158	157	14	11	3800	159	158	14	11	3825	160	159	14	11	3850	161	160	14	11	3875	162	161	14	11	3900	163	162	14	11	3925	164	163	14	11	3950	165	164	14	11	3975	166	165	14	11	4000	167	166	14	11	4025	168	167	14	11	4050	169	168	14	11	4075	170	169	14	11	4100	171	170	14	11	4125	172	171	14	11	4150	173	172	14	11	4175	174	173	14	11	4200	175	174	14	11	4225	176	175	14	11	4250	177	176	14	11	4275	178	177	14	11	4300	179	178	14	11	4325	180	179	14	11	4350	181	180	14	11	4375	182	181	14	11	4400	183	182	14	11	4425	184	183	14	11	4450	185	184	14	11	4475	186	185	14	11	4500	187	186	14	11	4525	188	187	14	11	4550	189	188	14	11	4575	190	189	14	11	4600	191	190	14	11	4625	192	191	14	11	4650	193	192	14	11	4675	194	193	14	11	4700	195	194	14	11	4725	196	195	14	11	4750	197	196	14	11	4775	198	197	14	11	4800	199	198	14	11	4825	200	199	14	11	4850	201	200	14	11	4875	202	201	14	11	4900	203	202	14	11	4925	204	203	14	11	4950	205	204	14	11	4975	206	205	14	11	5000	207	206	14	11	5025	208	207	14	11	5050	209	208	14	11	5075	210	209	14	11	5100	211	210	14	11	5125	212	211	14	11	5150	213	212	14	11	5175	214	213	14	11	5200	215	214	14	11	5225	216	215	14	11	5250	217	216	14	11	5275	218	217	14	11	5300	219	218	14	11	5325	220	219	14	11	5350	221	220	14	11	5375	222	221	14	11	5400	223	222	14	11	5425	224	223	14	11	5450	225	224	14	11	5475	226	225	14	11	5500	227	226	14	11	5525	228	227	14	11	5550	229	228	14	11	5575	230	229	14	11	5600	231	230	14	11	5625	232	231	14	11	5650	233	232	14	11	5675	234	233	14	11	5700	235	234	14	11	5725	236	235	14	11	5750	237	236	14	11	5775	238	237	14	11	5800	239	238	14	11	5825	240	239	14	11	5850	241	240	14	11	5875	242	241	14	11	5900	243	242	14	11	5925	244	243	14	11	5950	245	244	14	11	5975	246	245	14	11	6000	247	246	14	11	6025	248	247	14	11	6050	249	248	14	11

ENGINEERING PERFORMANCE DATA

SPIRAL DUCT GRILLES

Single and Double Deflection Adjustable - GDA Series



AIR PATTERN SETTINGS

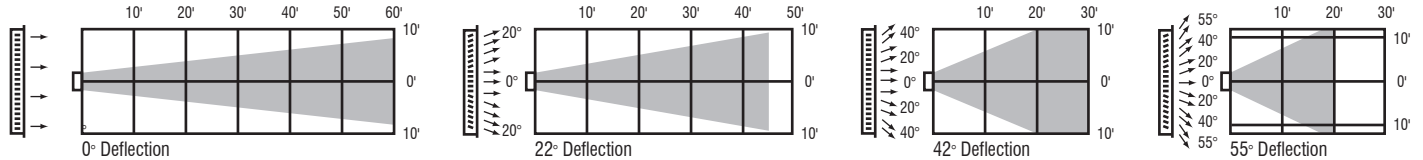


TABLE 1 (Cont'd)

LISTED HEIGHT				Outlet Velocity 900-1200 FPM					Outlet Velocity 1100-1450 FPM				Outlet Velocity 1250-1700 FPM				Outlet Velocity 1450-1900 FPM																										
				CFM	Deflection				CFM	Deflection				CFM	Deflection				CFM	Deflection																							
					0°	20°	40°	55°		0°	20°	40°	55°		0°	20°	40°	55°		0°	20°	40°	55°																				
					V _k					V _k					V _k					V _k																							
					900	1000	1100	1200		1100	1200	1300	1450		1250	1400	1550	1700		1450	1600	1750	1900																				
P _r				P _r				P _r				P _r																															
.05 .06 .08 .09				.08 .09 .10 .13				.09 .12 .15 .18				.13 .16 .19 .3																															
Throw (T) V _t 75				Throw (T) V _t 75				Throw (T) V _t 75				Throw (T) V _t 75																															
4	5	6	8	10	12	14	16	18	20	24																																	
6	5								80	13	11	9	7	100	15	13	11	8	125	18	15	13	10	150	19	16	13	10	175	21	18	14	11	225	27	23	19	15					
8	6								100	15	13	11	8	125	18	15	13	10	150	21	18	14	11	175	25	21	17	13	225	27	23	19	15	300	33	28	24	18	450	41	35	30	22
10	8	6							150	17	14	12	9	175	20	17	14	11	200	24	20	17	13	225	27	23	19	15	300	33	28	24	18	450	41	35	30	22	750	51	43	37	28
12	10	8							200	18	15	13	10	250	22	19	15	12	275	25	21	18	14	325	29	25	21	17	400	33	28	24	18	500	34	30	25	19	600	35	30	26	20
14	12	10	8						250	21	18	15	11	300	15	21	18	14	350	28	25	20	15	400	33	28	24	18	475	36	32	26	20	625	37	32	27	22	850	41	35	30	23
18	14	12							300	24	20	16	13	350	27	24	20	15	425	31	27	22	17	475	36	32	26	20	550	32	28	24	18	725	35	30	26	20	950	45	40	34	26
20	16	14	10						350	25	21	18	14	425	30	25	21	17	500	34	30	25	19	550	39	32	27	21	600	35	30	26	20	750	35	30	26	20	950	45	40	34	26
24	20	16	12	10					450	27	23	19	15	550	32	28	24	18	625	37	32	27	22	725	42	36	31	24	800	34	30	26	20	1000	39	33	28	22	1200	45	40	34	26
30	24	20	14	12					600	29	25	21	16	725	35	30	26	20	850	41	35	30	23	950	45	40	34	26	1000	39	33	28	22	1200	45	40	34	26	1500	51	43	37	28
38	30	24	18	14	12				700	32	28	24	18	850	39	33	28	21	975	45	39	33	25	1125	49	43	38	28	1250	43	37	32	24	1500	45	39	33	25	2000	52	47	42	32
40	32	26	20	16	14				800	34	30	25	19	950	41	35	30	22	1125	48	41	35	27	1275	52	46	40	31	1450	48	42	36	28	1675	57	48	42	32	2250	60	51	45	35
44	36	30	24	18	16	14			900	36	31	26	20	1075	43	37	32	24	1250	51	43	37	28	1450	55	49	42	32	1675	52	45	40	31	1950	60	51	45	35	2500	61	53	43	32
44	36	26	22	18	16				1000	39	33	28	22	1200	45	40	34	26	1400	53	45	39	30	1600	58	51	44	34	1925	51	44	37	30	2250	60	51	45	35	2750	61	53	43	32
48	40	30	24	20	18	16			1200	42	36	31	24	1450	48	42	36	28	1675	57	48	42	32	1925	61	54	46	36	2250	60	51	45	35	2750	61	53	43	32	3200	61	53	43	32
48	40	38	30	24	22	18			1400	45	39	34	26	1675	52	45	40	31	1950	60	51	45	35	2250	60	51	44	34	2500	61	53	43	32	2750	61	53	43	32	3200	61	53	43	32
									1600	47	43	37	28	1925	56	48	43	34	2250	61	53	43	32	2500	61	53	43	32	2750	61	53	43	32	3200	61	53	43	32	3200	61	53	43	32
									1800	49	44	40	31	2150	59	51	46	35	2500	61	53	43	32	2750	61	53	43	32	3200	61	53	43	32	3200	61	53	43	32	3200	61	53	43	32
									2000	52	47	42	32	2400	61	53	43	32	2800	61	53	43	32	3200	61	53	43	32	3200	61	53	43	32	3200	61	53	43	32	3200	61	53	43	32
									2500	56	50	45	34	3000	61	53	43	32	3500	61	53	43	32	4000	61	53	43	32	4200	61	53	43	32	4800	61	53	43	32	5600	61	53	43	32
									3000	61	53	43	32	3600	61	53	43	32	4200	61	53	43	32	4800	61	53	43	32	4900	61	53	43	32	5600	61	53	43	32	6000	61	53	43	32
									3500	61	53	43	32	4200	61	53	43	32	4900	61	53	43	32	5600	61	53	43	32	5600	61	53	43	32	6000	61	53	43	32	6000	61	53	43	32
									4000	61	53	43	32	4800	61	53	43	32	5600	61	53	43	32	6000	61	53	43	32	6000	61	53	43	32	6000	61	53	43	32	6000	61	53	43	32
									4500	61	53	43	32	5400	61	53	43	32	6000	61	53	43	32	6000	61	53	43	32	6000	61	53	43	32	6000	61	53	43	32	6000	61	53	43	32
									5000	61	53	43	32	6000	61	53	43	32	6000	61	53	43	32	6000	61	53	43	32	6000	61	53	43	32	6000	61	53	43	32	6000	61	53	43	32
									6000	61	53	43	32	6000	61	53	43	32	6000	61	53	43	32	6000	61	53	43	32	6000	61	53	43	32	6000	61	53	43	32	6000	61	53	43	32

DATA SHEET

ENGINEERING PERFORMANCE DATA

SPIRAL DUCT GRILLES

Single and Double Deflection Adjustable - GDA Series



THROW FACTORS

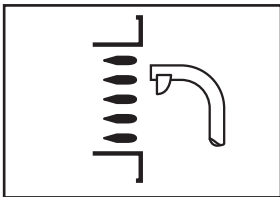
Throw values (T) in Table 1 are based on a Terminal Velocity (v_T) of 75 fpm. Throw values at other terminal velocities (v_T 50 to v_T 150 fpm) are established by multiplying throw (T) in table 1 by Throw Factor in table below.

Multiply Throw (T) in Table 1 by Factor				
VT (fpm)	50	75	100	150
Throw factor	x 1.5	x 1.0	x .76	x .5

Example;

A_k area for listed size 24" x 10" for GDA20 with deflection setting at 42° = 1.1 sq. feet.

AIR MEASUREMENT



2220A Velometer Jet for v_k velocity measurement $CFM = A_k \times v_k$

A_k OUTLET AREA IN SQ. FEET

LISTED WIDTH	LISTED HEIGHT								DEFLECTION						
	4	5	6	8	10	12	14	16	18	20	24	0°	22°	42°	55°
	6	5											.09	.08	.07
8	6											.11	.10	.09	.08
10	8	6										.17	.15	.13	.12
12	10	8										.22	.20	.18	.17
14	12	10	8									.28	.25	.23	.21
18	14	12										.33	.30	.27	.25
20	16	14	10									.39	.35	.32	.29
24	20	16	12	10								.50	.45	.41	.38
30	24	20	14	12								.67	.60	.55	.50
38	30	24	18	14	12							.78	.70	.64	.58
40	32	26	20	16	14							.89	.80	.73	.67
44	36	30	24	18	16	14						1.0	.90	.82	.75
44	36	26	22	18	16							1.1	1.0	.91	.83
48	40	30	24	20	18	16						1.3	1.2	1.1	1.0
	48	38	30	24	22	18						1.6	1.4	1.3	1.2
		40	32	28	24	20	18					1.8	1.6	1.5	1.3
		42	36	30	26	24	22	20				2.0	1.8	1.6	1.5
		46	42	36	30	26	24	22				2.2	2.0	1.8	1.7
				44	38	34	30	28	24			2.8	2.5	2.3	2.1
					48	42	36	34	28			3.3	3.0	2.7	2.5
						44	40	36	30			3.9	3.5	3.2	2.9
							48	42	36			4.5	4.0	3.6	3.3
								48	40			5.0	4.5	4.1	3.8
									42			5.6	5.0	4.5	4.2
									48			6.7	6.0	5.4	5.0

ENGINEERING PERFORMANCE DATA

SPIRAL DUCT GRILLES

Single and Double Deflection Adjustable - GDA Series



TOTAL AIR DROP FROM SIDEWALL OUTLET

The drop of an air stream varies directly with cooling temperature differential, throw and inversely with outlet velocity (V_k). The total drop of a cooled air stream is tabulated for two typical conditions of cooling temperature differentials and a range of throws and outlet velocities.

V_k in fpm	Sidewall Throw In Feet													
	10		15		20		25		30		40		50	
	- 18F	- 25F	- 18F	- 25F	- 18F	- 25F	- 18F	- 25F	- 18F	- 25F	- 18F	- 25F	- 18F	- 25F
500	3.5	4.0	5.5	6.0	7.5	8.5	9.0	10.0	10.5	13.5	15.5	18.0	18.5	23.0
750	2.5	3.5	4.0	5.5	6.0	6.5	7.0	8.0	8.5	10.5	11.5	14.5	15.0	18.5
1000	2.0	3.0	3.5	4.0	5.0	5.5	6.0	6.5	7.0	8.5	10.0	12.0	12.5	16.0
1250	2.0	2.5	3.0	3.5	4.5	5.0	5.5	6.0	6.5	7.5	9.0	11.0	11.5	13.5
1500	1.5	2.0	3.0	3.0	4.0	4.5	5.0	5.5	6.0	7.0	8.5	9.5	10.5	12.5
1750	1.0	2.0	2.5	2.5	3.5	4.0	4.5	5.0	5.5	6.5	8.0	9.0	10.0	11.5
2000	1.0	1.5	2.5	2.5	3.5	4.0	4.0	4.5	5.0	6.0	7.5	8.5	9.5	10.5

TOTAL AIR DROP

DROP DUE TO SPREAD + DROP DUE TO COOLING TEMPERATURE DIFFERENTIAL

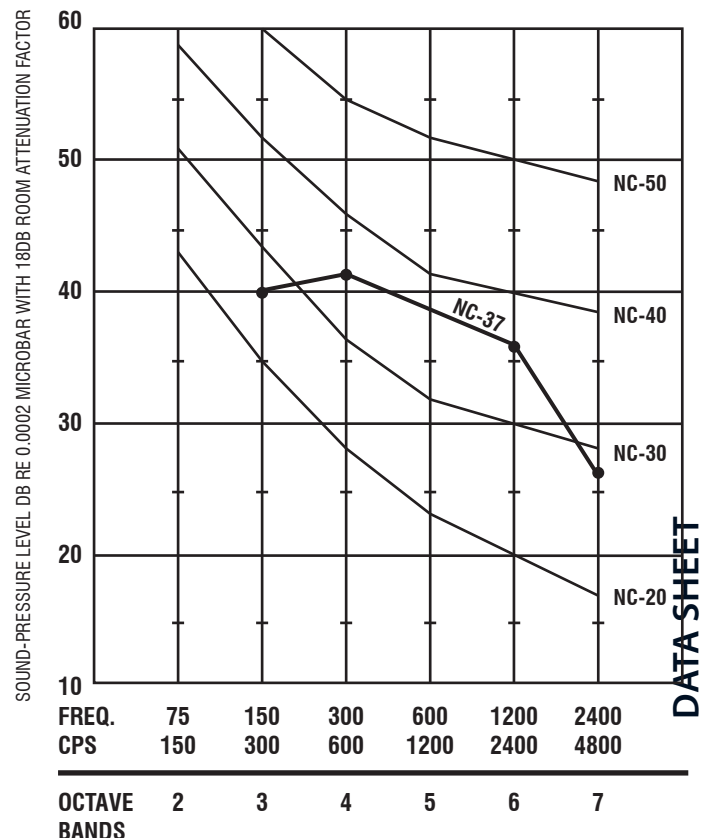
RECOMMENDED NC CRITERIA

NC Curve	Communication Environment	Typical Occupancy
Below NC 25	Extremely quiet environment, suppressed speech is quite audible, suitable for acute pickup of all sounds.	Broadcasting studios, concert halls, music rooms.
NC 30	Very quiet office, suitable for large conferences; telephone use satisfactory.	Resistances, theatres, libraries, executive offices, directors' rooms.
NC 35	Quiet office; satisfactory for conference at a 15 ft. table; normal voice 10-30 ft.; telephone use satisfactory.	Private offices, schools, hotel rooms, courtrooms, churches, hospital rooms.
NC 40	Satisfactory for conferences at a 6-8 ft. table; normal voice 6-12 ft.; telephone use satisfactory.	General offices, labs, dining rooms.
NC 45	Satisfactory for conferences at a 4-5 ft. table; normal voice 3-6 ft.; raised voice 6-12 ft.; telephone use occasionally difficult.	Retail store cafeterias, lobby areas, large drafting & engineering offices, reception areas.
Above NC 50	Unsatisfactory for conferences of more than two or three persons; normal voice 1-2 ft.; raised voice 3-6 ft.; telephone use slightly difficult.	IBM rooms, stenographic pools, print machine rooms, process areas.

TYPICAL NC SPECTRUM T64

24" x 6" 22° DEFLECTION

(975 CFM) V_k (1400 FPM)



ENGINEERING PERFORMANCE DATA

T-Bar lay-in return air grilles - Series GRT Fixed Bar Type 45° Deflected Bars



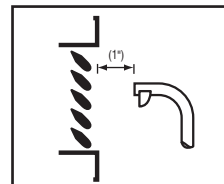
Listed Size W x H	A _K	NC 20-25 Application Non-Ducted		NC 25-30 Application Ducted		NC 30-40 Application Ducted	
		P _s		P _s		P _s	
		- .02"	- .03"	- .08"	- .10"	- .15"	- .20"
		CFM	CFM	CFM	CFM	CFM	CFM
10 x 6	.26	55	65	105	115	140	160
10 x 8	.34	75	90	145	160	195	225
12 x 8	.42	90	110	180	200	245	280
14 x 8	.50	110	135	220	245	300	345
12 x 10	.53	125	150	245	275	335	385
14 x 10	.63	155	190	310	345	420	485
12 x 12	.64	160	195	315	350	425	490
20 x 10	.75	170	205	335	375	455	525
14 x 14	.89	240	290	470	525	640	735
20 x 14	1.3	370	450	735	825	1005	1155
24 x 12	1.4	380	465	755	845	1030	1185
26 x 14	1.7	505	615	1000	1120	1365	1570
20 x 20	1.9	575	700	1140	1275	1555	1790
36 x 12	2.1	600	732	1195	1340	1635	1880
32 x 14	2.2	630	770	1255	1405	1715	1970
26 x 20	2.5	770	940	1530	1715	2090	2405
24 x 24	2.8	880	1075	1750	1960	2390	2750
32 x 20	3.2	970	1185	1930	2160	2635	3030
26 x 26	3.3	1040	1270	2070	2320	2830	3255
38 x 20	3.8	1170	1425	2320	2600	3170	3645
32 x 26	4.1	1320	1610	2625	2940	3585	4120
36 x 24	4.3	1355	1655	2695	3020	3685	4235
38 x 26	4.9	1580	1925	3135	3510	4280	4920
48 x 24	5.9	1940	2365	3855	4315	5265	6055
38 x 30	6.1	2010	2450	3995	4475	5460	6280
50 x 26	6.6	2130	2600	4240	4750	5795	6665
50 x 32	8.1	2700	3295	5370	6015	7340	8440
50 x 38	9.7	3220	3930	6405	7175	8755	10065

Performance of any size not shown in the tables will be the same as for the size shown with the same listed size area.

EXAMPLE:

A 38 x 18 size (not shown) has a listed area of 576 sq. in. Its performance will be identical to a 26 x 26 size (shown) which has the same listed size area of 576 sq. in.

AIR MEASUREMENT



SYMBOLS P_s Static Pressure Inches H₂O
A_K Outlet Area, 1" Out from Face
NC Re 10 db Room attenuation

2220A Velometer Jet for V_K velocity measurement.
CFM = A_K x V_K

GRILLES & REGISTERS



	ALUMINUM	STEEL	
MODELS	GAA1	GSA1	supply, single deflection
	GAA2	GSA2	supply, double deflection
	GAA4	GSA4	return, single row, fixed 45 degree



FRONT ROW BLADES DIRECTION: Parallel to width, (default) or add suffix H Parallel to height, add suffix V

DAMPERS: Grilles (no damper) Register (with damper): For registers with steel opposed blade damper: add suffix 7

Single deflection supply grilles and registers are recommended for applications requiring pattern adjustability in a single horizontal or vertical plane, sill or sidewall location at ceiling line, or heating application only.

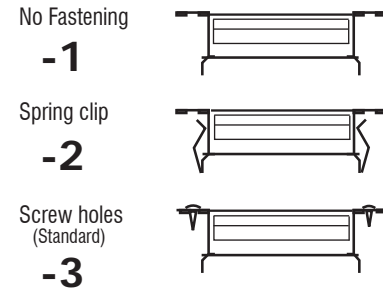
Double-deflection supply grilles and registers are recommended for application in systems requiring optimum flexibility of pattern change to accommodate changing job conditions.

The combination of streamlined foil shaped bars and 17 mm (2/3-inch) bar spacing maintains a high effective area capacity of greater than 80% which minimizes outlet velocity, reduces pressure drop and assures quiet operation. Individually adjustable bars are capable of shortening throw up to one-half with a wide spread deflection requiring only a 20% increase in outlet velocity at a fixed volume.

GAA Series (aluminum) have extruded aluminum frames with roll formed aluminum bars.

GSA Series (steel) have extruded aluminum frames with steel bars. This unique feature combines the beauty and rust resistance of the aluminium frame with the rigidity of steel bars.

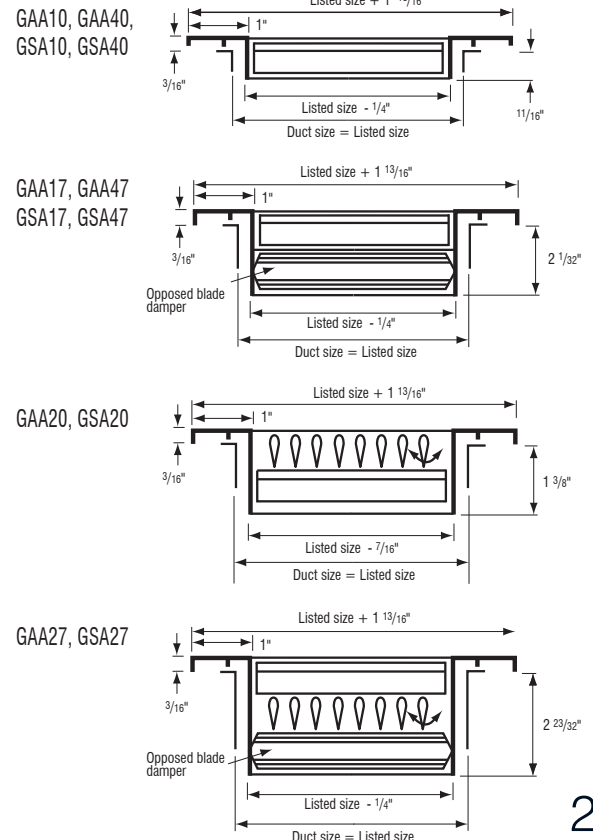
Fastening Methods



Accessories

-SF	-DS	-IS
Supplied w/ sub frame	Debris (Bird) Screen	Insect Screen

Dimensions



HOW TO ORDER GSA/GAA SERIES

GSA17-V -1-SF 1004 /W

MODEL SERIES GSA Steel GAA Aluminium	FINISH (Optional) White (Standard) /W Custom (See chart) /C
AIR PATTERN Single Adjust. 1 Double Adjust. 2 Single Fixed 4	WIDTH (INCHES)
GRILLE/REGISTER Grille 0 Register 7	LENGTH (INCHES)
BLADE ORIENTATION (Optional) Horizontal (Standard) -H Vertical -V	OPTIONS Sub Frame -SF Debris Screen -DS Insect Screen -IS
FASTENING METHOD (Optional) No Fastening -1 Spring Clip -2 Screw (Standard) -3	

MAX. LISTED SIZE: 36"x36" (multiple sections furnished for larger sizes)
FINISH: Powder baked enamel paint for durability. White is standard. (Other finishes available).

DATA SHEET

ENGINEERING PERFORMANCE DATA

SUPPLY AIR GRILLES AND REGISTERS Single and Double Deflection adjustable Type - Series GSA & GAA



TABLE 1

LISTED HEIGHT				Outlet Velocity 450-600 FPM				Outlet Velocity 550-700 FPM				Outlet Velocity 600-800 FPM				Outlet Velocity 700-1000 FPM												
				CFM	Deflection				CFM	Deflection				CFM	Deflection				CFM	Deflection								
					0°	22°	42°	55°		0°	22°	42°	55°		0°	22°	42°	55°		0°	22°	42°	55°					
					V _K					V _K					V _K					V _K								
					450	500	550	600		550	600	650	700		600	700	750	800		700	800	900	1000					
P _T				P _T				P _T				P _T																
Throw (T) V _T 75				Throw (T) V _T 75				Throw (T) V _T 75				Throw (T) V _T 75																
4	5	6	8	10	12	14	16	18	20	24																		
6	5								40	6	5	4	3	45	8	7	6	4	60	10	9	7	5	65	11	10	8	6
8	6								50	7	6	5	4	60	9	11	6	5	70	11	10	8	6	80	12	11	9	7
10	8	6							75	9	7	6	5	90	10	9	7	6	100	12	11	9	7	125	13	12	10	8
12	10	8							100	10	8	6	5	125	11	9	8	7	150	13	12	9	8	175	14	13	11	8
14	12	10	8						125	11	9	7	6	150	12	11	9	7	175	14	13	10	8	200	16	14	11	9
18	14	12							150	11	10	8	7	175	13	11	10	8	200	15	14	11	9	250	17	15	12	10
20	16	14	10						175	12	11	9	7	200	15	13	11	9	250	17	15	12	9	275	19	17	14	11
24	20	16	12	10					225	13	12	10	8	275	16	14	12	10	300	19	16	13	10	350	21	18	15	12
30	24	20	14	12					300	14	13	11	9	350	18	15	13	10	425	20	17	15	11	475	24	20	17	13
38	30	24	18	14	12				350	17	14	12	9	425	20	17	13	11	500	22	20	17	12	550	26	22	18	14
40	32	26	20	16	14				400	18	16	13	10	475	21	18	15	12	550	24	21	18	13	650	28	24	20	15
44	36	30	24	18	16	14			450	19	17	13	11	550	22	19	17	13	625	26	22	19	14	725	30	25	22	17
44	36	26	22	18	16				500	20	17	14	12	600	24	20	18	13	700	27	24	20	15	800	32	27	23	18
48	40	30	24	20	18	16			600	21	18	15	12	700	25	22	18	14	850	29	25	22	16	950	34	29	25	19
48	38	30	24	22	18				700	23	20	17	13	850	28	24	20	15	975	33	28	24	18	1125	37	31	27	21
	40	32	28	24	20	18			800	25	21	18	14	950	31	26	22	17	1125	35	30	26	20	1275	39	34	29	22
	42	36	30	26	24	22	20		900	27	22	19	15	1100	32	27	23	18	1250	36	31	27	21	1450	42	36	31	23
	46	42	36	30	26	24	22		1000	29	25	21	16	1200	34	29	25	19	1400	40	34	29	22	1600	45	39	34	25
		44	38	34	30	28	24		1250	32	27	23	18	1500	36	30	27	23	1750	43	37	31	24	2000	48	43	36	27
			48	42	36	34	28		1500	34	29	25	19	1800	39	32	29	25	2100	45	40	34	26	2400	52	46	39	30
				44	40	36	30		1750	37	32	27	21	2100	42	35	32	27	2450	48	44	37	28	2800	55	49	42	32
				48	42	36			2000	39	34	29	22	2400	45	38	34	29	2800	52	46	40	30	3200	58	52	44	34
				48	40				2250	41	36	30	24	2700	48	40	36	31	3150	54	48	42	32	3600	61	54	46	37
				42					2500	43	38	32	25	3000	51	42	38	33	3500	57	51	44	33	4000	64	57	49	39
				48					3000	46	40	34	27	3600	54	45	40	35	4200	60	53	47	35	4800	68	60	52	42

NC 30
NC 35



NC40

- SYMBOLS
- V_T Terminal Velocity in fpm
 - V_R Room Velocity in fpm
 - V_K Outlet Velocity in fpm
 - A_K Outlet area in Sq. Feet
 - P_T Total Pressure H₂O
 - P_S Static Pressure H₂O
 - NC Re 8db Room attenuation
 - T Throw in feet at X and Y

ENGINEERING PERFORMANCE DATA

SUPPLY AIR GRILLES AND REGISTERS Single and Double Deflection adjustable Type - Series GSA & GAA



AIR PATTERN SETTINGS

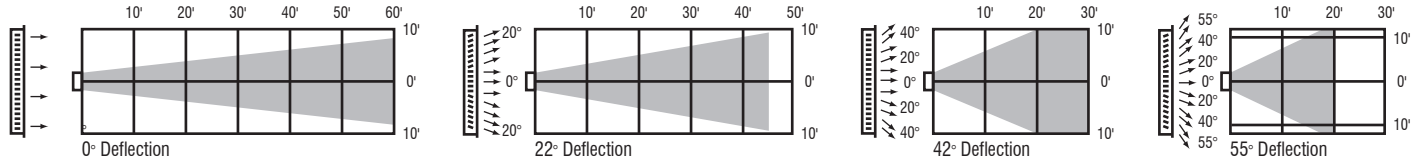


TABLE 1 (Cont'd)

LISTED HEIGHT				Outlet Velocity 900-1200 FPM					Outlet Velocity 1100-1450 FPM				Outlet Velocity 1250-1700 FPM				Outlet Velocity 1450-1900 FPM																			
				CFM	Deflection				CFM	Deflection				CFM	Deflection				CFM	Deflection																
					0°	20°	40°	55°		0°	20°	40°	55°		0°	20°	40°	55°		0°	20°	40°	55°													
					V _k					V _k					V _k					V _k																
					900	1000	1100	1200		1100	1200	1300	1450		1250	1400	1550	1700		1450	1600	1750	1900													
P _r				P _r				P _r				P _r																								
.05 .06 .08 .09				.08 .09 .10 .13				.09 .12 .15 .18				.13 .16 .19 .3																								
Throw (T) V _t 75				Throw (T) V _t 75				Throw (T) V _t 75				Throw (T) V _t 75																								
4	5	6	8	10	12	14	16	18	20	24																										
6	5										80	13	11	9	7	100	15	13	11	8	125	18	15	13	10	150	24	20	17	13	225	27	23	19	15	
8	6										100	15	13	11	8	125	18	15	13	10	150	21	18	14	11	175	25	21	17	13	225	27	23	19	15	
10	8	6									150	17	14	12	9	175	20	17	14	11	200	24	20	17	13	225	27	23	19	15	225	27	23	19	15	
12	10	8									200	18	15	13	10	250	22	19	15	12	275	25	21	18	14	325	29	25	21	17	400	33	28	24	18	
14	12	10	8								250	21	18	15	11	300	15	21	18	14	350	28	25	20	15	400	33	28	24	18	475	36	32	26	20	
18	14	12									300	24	20	16	13	350	27	24	20	15	425	31	27	22	17	475	36	32	26	20	475	36	32	26	20	
20	16	14	10								350	25	21	18	14	425	30	25	21	17	500	34	30	25	19	550	39	32	27	21	625	42	36	31	24	
24	20	16	12	10							450	27	23	19	15	550	32	28	24	18	625	37	32	27	22	725	42	36	31	24	725	42	36	31	24	
30	24	20	14	12							600	29	25	21	16	725	35	30	26	20	850	41	35	30	23	950	45	40	34	26	950	45	40	34	26	
38	30	24	18	14	12						700	32	28	24	18	850	39	33	28	21	975	45	39	33	25	1125	49	43	38	28	1125	49	43	38	28	
40	32	26	20	16	14						800	34	30	25	19	950	41	35	30	22	1125	48	41	35	27	1275	52	46	40	31	1275	52	46	40	31	
44	36	30	24	18	16	14					900	36	31	26	20	1075	43	37	32	24	1250	51	43	37	28	1450	55	49	42	32	1450	55	49	42	32	
44	36	26	22	18	16						1000	39	33	28	22	1200	45	40	34	26	1400	53	45	39	30	1600	58	51	44	34	1600	58	51	44	34	
48	40	30	24	20	18	16					1200	42	36	31	24	1450	48	42	36	28	1675	57	48	42	32	1925	61	54	46	36	1925	61	54	46	36	
48	38	30	24	22	18						1400	45	39	34	26	1675	52	45	40	31	1950	60	51	45	35	2250	58	49	40	34	2250	58	49	40	34	
	40	32	28	24	20	18					1600	47	43	37	28	1925	56	48	43	34	2250	54	47	39	2500		62	53	43	2500		62	53	43		
	42	36	30	26	24	22	20				1800	49	44	40	31	2150	59	51	46	35	2500	57	50	41	2750			56	46	2750			56	46		
	46	42	36	30	26	24	22	20			2000	52	47	42	32	2400	54	49	43	38	2800	61	53	43	3200			59	48	3200			59	48		
			44	38	34	30	28	24			2500	56	50	45	34	3000		53	41	3500		58	47	4000				54	47	4000				54		
			48	42	36	34	28	24			3000	60	54	48	36	3600		58	44	4200		58	44	4800				52	48	4800				52		
				44	40	36	30	24			3500		59	53	40	4200		49	49	4900		49	49	56				56						56		
					48	42	36	30	28	24	4000			57	43	4800			54	5600			60													
					48	40					4500			60	45	5400			58																	
					42						5000				49																					
					48						6000				54																					

DATA SHEET

ENGINEERING PERFORMANCE DATA

SUPPLY AIR GRILLES AND REGISTERS

Single and Double Deflection adjustable Type - Series GSA & GAA



THROW FACTORS

Throw values (T) in Table 1 are based on a Terminal Velocity (v_T) of 75 fpm. Throw values at other terminal velocities (v_T 50 to v_T 150 fpm) are established by multiplying throw (T) in table 1 by Throw Factor in table below.

Multiply Throw (T) in Table 1 by Factor				
VT (fpm)	50	75	100	150
Throw factor	x 1.5	x 1.0	x .76	x .5

Grille sound ratings will be increased by integral or localized air volume dampening, by non-uniform air flow in the grille collar and by the addition of inherent system noise.

REGISTER THROTTLING CORRECTION

Damper throttling effect (excess pressure drop due to part closing of damper)	Press. Drop In. H ₂ O		
	.05"	.05"	.05"
Approximate damper opening	3/4	2/3	1/2
NC addition to single outlet sound rating	5	10	15

Damper throttling effect = excess pressure drop created by partially closing the register damper.

NC addition to be added to NC values of table 1.

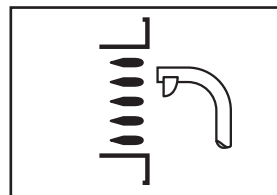
A_k OUTLET AREA IN SQ. FEET

LISTED WIDTH	LISTED HEIGHT								DEFLECTION						
	4	5	6	8	10	12	14	16	18	20	24	0°	22°	42°	55°
	6	5											.09	.08	.07
8	6											.11	.10	.09	.08
10	8	6										.17	.15	.13	.12
12	10	8										.22	.20	.18	.17
14	12	10	8									.28	.25	.23	.21
18	14	12										.33	.30	.27	.25
20	16	14	10									.39	.35	.32	.29
24	20	16	12	10								.50	.45	.41	.38
30	24	20	14	12								.67	.60	.55	.50
38	30	24	18	14	12							.78	.70	.64	.58
40	32	26	20	16	14							.89	.80	.73	.67
44	36	30	24	18	16	14						1.0	.90	.82	.75
44	36	26	22	18	16							1.1	1.0	.91	.83
48	40	30	24	20	18	16						1.3	1.2	1.1	1.0
48	48	38	30	24	22	18						1.6	1.4	1.3	1.2
		40	32	28	24	20	18					1.8	1.6	1.5	1.3
		42	36	30	26	24	22	20				2.0	1.8	1.6	1.5
		46	42	36	30	26	24	22				2.2	2.0	1.8	1.7
				44	38	34	30	28	24			2.8	2.5	2.3	2.1
					48	42	36	34	28			3.3	3.0	2.7	2.5
						44	40	36	30			3.9	3.5	3.2	2.9
							48	42	36			4.5	4.0	3.6	3.3
								48	40			5.0	4.5	4.1	3.8
									42			5.6	5.0	4.5	4.2
										48		6.7	6.0	5.4	5.0

Example;

Listed size 24 x 10 GAA27 deflection setting 42° A_k area = 1.1 sq. feet.

AIR MEASUREMENT



2220A Velometer Jet for v_k velocity measurement CFM = A_k x V_k

EXAMPLE:

A 36 x 16 size (not shown) has a listed area of 576 sq. in. Its performance will be identical to a 24 x 24 size (shown) which has the same listed size area of 576 sq. in.

ENGINEERING PERFORMANCE DATA

SUPPLY AIR GRILLES AND REGISTERS

Single and Double Deflection adjustable Type - Series GSA & GAA



Total air drop from sidewall outlet

The drop of an air stream varies directly with cooling temperature differential, throw and inversely with outlet velocity (V_k). The total drop of a cooled air stream is tabulated for two typical conditions of cooling temperature differentials and a range of throws and outlet velocities.

V_k in fpm	Sidewall Throw In Feet													
	10		15		20		25		30		40		50	
	- 18F	- 25F	- 18F	- 25F	- 18F	- 25F	- 18F	- 25F	- 18F	- 25F	- 18F	- 25F	- 18F	- 25F
500	3.5	4.0	5.5	6.0	7.5	8.5	9.0	10.0	10.5	13.5	15.5	18.0	18.5	23.0
750	2.5	3.5	4.0	5.5	6.0	6.5	7.0	8.0	8.5	10.5	11.5	14.5	15.0	18.5
1000	2.0	3.0	3.5	4.0	5.0	5.5	6.0	6.5	7.0	8.5	10.0	12.0	12.5	16.0
1250	2.0	2.5	3.0	3.5	4.5	5.0	5.5	6.0	6.5	7.5	9.0	11.0	11.5	13.5
1500	1.5	2.0	3.0	3.0	4.0	4.5	5.0	5.5	6.0	7.0	8.5	9.5	10.5	12.5
1750	1.0	2.0	2.5	2.5	3.5	4.0	4.5	5.0	5.5	6.5	8.0	9.0	10.0	11.5
2000	1.0	1.5	2.5	2.5	3.5	4.0	4.0	4.5	5.0	6.0	7.5	8.5	9.5	10.5

TOTAL AIR DROP

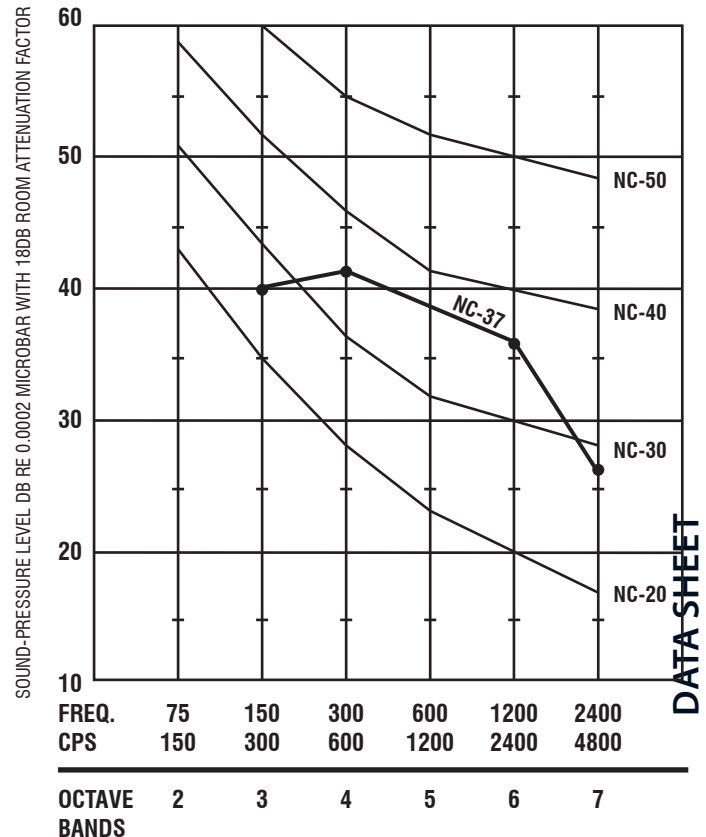
DROP DUE TO SPREAD + DROP DUE TO COOLING TEMPERATURE DIFFERENTIAL

RECOMMENDED NC CRITERIA

NC Curve	Communication Environment	Typical Occupancy
Below NC 25	Extremely quiet environment, suppressed speech is quite audible, suitable for acute pickup of all sounds.	Broadcasting studios, concert halls, music rooms.
NC 30	Very quiet office, suitable for large conferences; telephone use satisfactory.	Residences, theatres, libraries, executive offices, directors' rooms.
NC 35	Quiet office; satisfactory for conference at a 15 ft. table; normal voice 10-30 ft.; telephone use satisfactory.	Private offices, schools, hotel rooms, courtrooms, churches, hospital rooms.
NC 40	Satisfactory for conferences at a 6-8 ft. table; normal voice 6-12 ft.; telephone use satisfactory.	General offices, labs, dining rooms.
NC 45	Satisfactory for conferences at a 4-5 ft. table; normal voice 3-6 ft.; raised voice 6-12 ft.; telephone use occasionally difficult.	Retail store cafeterias, lobby areas, large drafting & engineering offices, reception areas.
Above NC 50	Unsatisfactory for conferences of more than two or three persons; normal voice 1-2 ft.; raised voice 3-6 ft.; telephone use slightly difficult.	IBM rooms, stenographic pools, print machine rooms, process areas.

TYPICAL NC SPECTRUM T64

24" x 6" 22° DEFLECTION
(975 CFM) V_k (1400 FPM)



ENGINEERING PERFORMANCE DATA

RETURN AIR GRILLES AND REGISTERS Fixed Bar Type 45° Deflected Bars



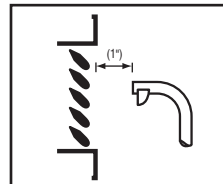
Listed Size W x H	A _K	NC 20-25 Application Non-Ducted		NC 25-30 Application Ducted		NC 30-40 Application Ducted	
		P _s		P _s		P _s	
		- .02"	- .03"	- .08"	- .10"	- .15"	- .20"
		CFM	CFM	CFM	CFM	CFM	CFM
8 x 4	.26	55	65	105	115	140	160
8 x 6	.34	75	90	145	160	195	225
10 x 6	.42	90	110	180	200	245	280
12 x 6	.50	110	135	220	245	300	345
10 x 8	.53	125	150	245	275	335	385
12 x 8	.63	155	190	310	345	420	485
10 x 10	.64	160	195	315	350	425	490
18 x 6	.75	170	205	335	375	455	525
12 x 12	.89	240	290	470	525	640	735
18 x 12	1.3	370	450	735	825	1005	1155
22 x 10	1.4	380	465	755	845	1030	1185
24 x 12	1.7	505	615	1000	1120	1365	1570
18 x 18	1.9	575	700	1140	1275	1555	1790
34 x 10	2.1	600	732	1195	1340	1635	1880
30 x 12	2.2	630	770	1255	1405	1715	1970
24 x 18	2.5	770	940	1530	1715	2090	2405
22 x 22	2.8	880	1075	1750	1960	2390	2750
30 x 18	3.2	970	1185	1930	2160	2635	3030
24 x 24	3.3	1040	1270	2070	2320	2830	3255
36 x 18	3.8	1170	1425	2320	2600	3170	3645
30 x 24	4.1	1320	1610	2625	2940	3585	4120
34 x 22	4.3	1355	1655	2695	3020	3685	4235
36 x 24	4.9	1580	1925	3135	3510	4280	4920
46 x 22	5.9	1940	2365	3855	4315	5265	6055
36 x 30	6.1	2010	2450	3995	4475	5460	6280
48 x 24	6.6	2130	2600	4240	4750	5795	6665
48 x 30	8.1	2700	3295	5370	6015	7340	8440
48 x 36	9.7	3220	3930	6405	7175	8755	10065

Performance of any size not shown in the tables will be the same as for the size shown with the same listed size area.

EXAMPLE:

A 36 x 16 size (not shown) has a listed area of 576 sq. in. Its performance will be identical to a 24 x 24 size (shown) which has the same listed size area of 576 sq. in.

AIR MEASUREMENT



2220A Velometer Jet for V_k velocity measurement.

$$CFM = A_K \times V_K$$

DATA SHEET

SYMBOLS P_s Static Pressure Inches H₂O
A_K Outlet Area, 1" Out from Face
NC Re 10 db Room attenuation

HOW TO SPECIFY GRILLES AND REGISTERS



Single Deflection Aluminum Supply Register

Supply and mounting of single deflection register with opposed blade damper, series **GAA17**. 2/3 inch blade spacing, constructed from powder coated aluminum, manufactured by Airvector.

Single Deflection Aluminum Return Grille

Supply and mounting of single deflection return grille, series **GAA10**. 2/3 inch blade spacing, constructed from powder coated aluminum, manufactured by Airvector.

Single Deflection Steel Supply Register

Supply and mounting of single deflection register with opposed blade damper, series **GSA17**. 2/3 inch blade spacing, constructed from powder coated aluminum frame and steel blades, manufactured by Airvector.

Single Deflection Steel Return Grille

Supply and mounting of single deflection return grille, series **GSA10**. 2/3 inch blade spacing, constructed from powder coated aluminum frame and steel blades, manufactured by Airvector.

Double Deflection Aluminum Supply Register

Supply and mounting of double deflection register with opposed blade damper, series **GAA27**. 2/3 inch blade spacing, constructed from powder coated aluminum, manufactured by Airvector.

Double Deflection Aluminum Return Grille

Supply and mounting of double deflection return grille, series **GAA20**. 2/3 inch blade spacing, constructed from powder coated aluminum, manufactured by Airvector.

Double Deflection Steel Supply Register

Supply and mounting of double deflection register with opposed blade damper, series **GSA27**. 2/3 inch blade spacing, constructed from powder coated aluminum frame and steel blades, manufactured by Airvector.

Double Deflection Steel Return Grille

Supply and mounting of double deflection return grille, series **GSA20**. 2/3 inch blade spacing, constructed from powder coated aluminum frame and steel blades, manufactured by Airvector.

Fixed 45° Aluminum Supply Register

Supply and mounting of 45 degree fixed blade register with opposed blade damper, series **GAA47**. 2/3 inch blade spacing, constructed from powder coated aluminum, manufactured by Airvector.

Fixed 45° Aluminum Return Grille

Supply and mounting of 45 degree fixed blade return grille, series **GAA40**. 2/3 inch blade spacing, constructed from powder coated aluminum, manufactured by Airvector.

Fixed 45° Steel Supply Register

Supply and mounting of 45 degree fixed blade register with opposed blade damper, series **GSA47**. 2/3 inch blade spacing, constructed from powder coated aluminum frame and steel blades, manufactured by Airvector.

Fixed 45° Steel Return Grille

Supply and mounting of 45 degree fixed blade return grille, series **GSA40**. 2/3 inch blade spacing, constructed from powder coated aluminum frame and steel blades, manufactured by Airvector.

SQUARE DIFFUSERS



MODELS ISA, ISAI, ISAM ARCHITECTURAL PLAQUE DIFFUSERS

MODEL **ISA** - Square neck

MODEL **ISAM** - Round neck

MODEL **ISAI** - Insulated

ISA Series supply diffusers are recommended for heating, ventilating and cooling.

The ISA series provide a 360° air diffusion pattern with an adjustable opening. The face panel can be adjustable by the means of four spring-loaded countersunk screws to increase or decrease the air throw.

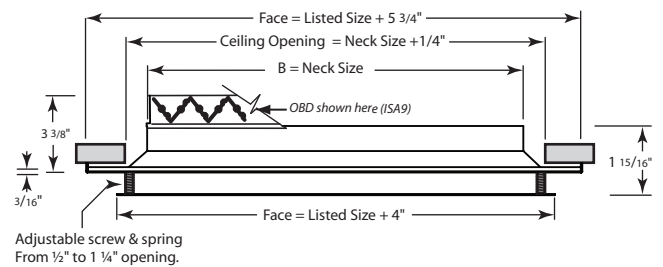
Features:

- Full Face 12"x12", 15"x15", 18"x18", 21"x21" and 24"x24"
- 1 Way, 2 Way Opposed, 2 Way Corner, 3 Way or 4 Way
- Commercial-grade aluminum construction
- Core can be easily removed without tools
- Ideal for VAV systems
- Powder paint coating - White (default) Custom colours avail.

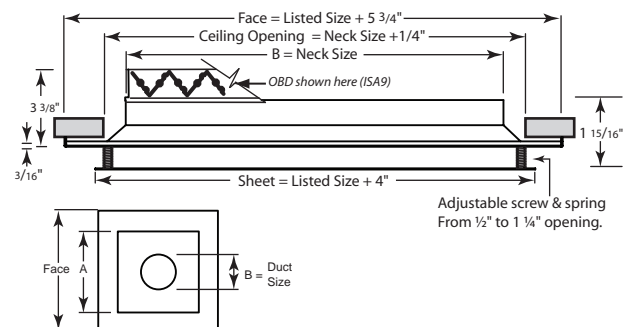


ISA

ISA/ISA9



ISAM/ISAM4/ISAM5



PERFORMANCE DATA

SERIES ISA

PLAQUE DIFFUSERS



6" x 6" Square Neck

Face Opening (inches)	Neck Velocity (fpm)	165	250	335	420	625	830	1035	1240	1445
	Velocity Pressure (in H ₂ O)	.003	.005	.007	.011	.024	.041	.064	.091	.123
	Airflow, CFM	50	70	90	110	160	210	260	310	360
1.25"	Total Pressure				.04	.07	.11	.17	.24	.32
	NC				14	19	22	26	31	37
	Throw (ft)				1	3	5	6	7	9
1"	Total Pressure			.03	.04	.08	.12	.18	.27	.35
	NC			–	14	19	22	26	32	38
	Throw (ft)			1	2	4	6	7	9	11
0.75"	Total Pressure	.01	.02	.03	.04	.09	.14	.22	.31	.42
	NC	–	–	–	14	19	22	26	32	38
	Throw (ft)	1	2	3	4	5	7	8	9	11
0.5"	Total Pressure	.02	.03	.04	.06	.11	.29	.28	.42	.57
	NC	–	–	–	21	24	31	38	43	47
	Throw (ft)	2	3	4	5	6	8	9	10	12

9" x 9" Square Neck

Face Opening (inches)	Neck Velocity (fpm)	94	144	193	287	381	474	568	751	845
	Velocity Pressure (in H ₂ O)	–	.001	.003	.005	.009	.013	.019	.032	.141
	Airflow, CFM	60	85	110	160	210	260	310	410	460
1.25"	Total Pressure				.02	.02	.04	.07	.11	.13
	NC				13	18	21	24	33	38
	Throw (ft)				2	3	5	6	8	10
1"	Total Pressure			.02	.03	.04	.06	.08	.13	.16
	NC			–	14	19	22	25	34	40
	Throw (ft)			2	4	5	6	7	10	12
0.75"	Total Pressure		.01	.02	.03	.05	.08	.11	.18	.22
	NC		–	–	15	20	23	36	36	41
	Throw (ft)		2	3	6	6	7	9	11	13
0.5"	Total Pressure	–	.01	.03	.05	.07	.13	.18	.30	.38
	NC	–	–	–	15	21	23	27	38	43
	Throw (ft)	2	3	4	6	7	9	10	13	14

12" x 12" Square Neck

Face Opening (inches)	Neck Velocity (fpm)	55	110	165	220	275	330	435	540	650
	Velocity Pressure (in H ₂ O)	–	.001	.003	.004	.005	.007	.011	.016	.024
	Airflow, CFM	60	110	160	210	260	310	410	510	560
1.25"	Total Pressure			.01	.02	.03	.04	.05	.08	.10
	NC			–	14	19	22	26	31	37
	Throw (ft)			3	4	6	7	9	12	13
1"	Total Pressure		–	.01	.02	.04	.05	.07	.10	.13
	NC		–	–	14	18	22	26	32	38
	Throw (ft)		2	4	5	7	8	10	13	15
0.75"	Total Pressure		.01	.02	.04	.05	.07	.10	.16	.19
	NC		3	5	6	7	9	11	14	15
	Throw (ft)		–	–	14	19	23	28	36	38
0.5"	Total Pressure	–	.03	.04	.06	.08	.11	.19	.29	.35
	NC	–	–	–	15	21	24	31	39	46
	Throw (ft)	2	3	4	5	6	8	9	15	17

NC Value based on 10 db room attenuation.

Throw Values are based on isothermal air and terminal velocities of 150 fpm, 100 fpm & 75 fpm respectively
Total Pressure the sum of static pressure plus velocity pressure and is given in inches w.g.

PERFORMANCE DATA

SERIES ISA

PLAQUE DIFFUSERS



15" x 15" Square Neck

Face Opening (inches)	Neck Velocity (fpm)	37	74	111	148	215	286	355	424	493
	Velocity Pressure (in H ₂ O)	.001	.002	.002	.002	.003	.005	.007	.010	.014
	Airflow, CFM	50	100	150	200	300	400	500	600	700
1.25"	Total Pressure				.01	.02	.03	.05	.07	.10
	NC				–	19	23	27	34	40
	Throw (ft)				–	5	6	9	10	12
1"	Total Pressure			.03	.04	.08	.12	.18	.27	.35
	NC			–	14	20	24	29	36	43
	Throw (ft)			2	4	6	8	10	12	14
0.75"	Total Pressure		.01	.01	.02	.04	.08	.11	.15	.20
	NC		–	–	–	16	22	27	33	41
	Throw (ft)		2	4	5	8	11	13	15	17
0.5"	Total Pressure	.01	.02	.03	.04	.08	.14	.21	.29	.39
	NC	–	–	–	16	22	27	33	41	49
	Throw (ft)	2	3	5	6	9	12	15	18	21

18" x 18" Square Neck

Face Opening (inches)	Neck Velocity (fpm)	27	54	104	153	203	252	302	351	401
	Velocity Pressure (in H ₂ O)	.001	.002	.002	.002	.003	.004	.006	.007	.009
	Airflow, CFM	50	100	200	300	400	500	600	700	800
1.25"	Total Pressure			.01	.03	.04	.06	.08	.11	.14
	NC			–	15	21	23	19	34	41
	Throw (ft)			2	4	6	7	9	11	13
1"	Total Pressure			.02	.03	.04	.06	.08	.11	.14
	NC			–	15	21	25	29	36	44
	Throw (ft)			3	5	8	9	10	14	15
0.75"	Total Pressure	.01	.01	.02	.04	.06	.08	.13	.16	.21
	NC	–	–	–	16	22	26	32	38	47
	Throw (ft)	2	3	5	7	9	10	14	16	18
0.5"	Total Pressure	–	.01	.03	.06	.11	.15	.23	.30	.39
	NC	–	–	11	17	23	28	34	41	51
	Throw (ft)	2	4	6	9	12	14	17	19	21

NC Value based on 10 db room attenuation.

Throw Values are based on isothermal air and terminal velocities of 150 fpm, 100 fpm & 75 fpm respectively
Total Pressure the sum of static pressure plus velocity pressure and is given in inches w.g.

PERFORMANCE DATA

SERIES ISA/ISAM

PLAQUE DIFFUSERS



HOW TO ORDER ISA SERIES

ISA-3-A1-ES-Y2424 0606 /W

MODEL SERIES

Adjustable Plaque Diffusers **ISA**
 ...with OBD **ISA9**
 ...Insulated **ISAI**

FINISH (OPTIONAL)

Standard is White (**/W**)
 See chart for more

MOUNTING (OPTIONAL)

Default is lay-In (-0),
 no need to specify
 Lay-In (default) **-0**
 Screw Holes in Face **-3**
 Concealed **-4**

NECK DIMENSIONS

In Inches
 6" x 6" **0606**
 9" x 9" **0909**
 12" x 12" **1212**
 15" x 15" **1515**
 18" x 18" **1818**

DIRECTION (OPTIONAL)

1 Baffle **-A1**
 2 Corner Baffles **-AC**
 2 Opposed Baffles **-AO**
 3 Baffles **-A3**
 4 Baffles **-A4**

FACE DIMENSIONS

12" x 24" **-Y1224**
 24" x 12" **-Y2412**
 24" x 24" **-Y2424**
 24" x 48" **-Y2448**
 48" x 24" **-Y4824**
 20" x 20" **-Y2020**

OPTION

Square equalizing grid **-ES**

HOW TO ORDER ISAM SERIES

ISAM-3-A1 R4 EG-Y2424 0606 06 /W

MODEL SERIES

Adjustable Plaque Diffusers **ISAM**
 ...with OBD **ISAM4**
 ...Insulated **ISAM5**

FINISH (OPTIONAL)

Standard is White (**/W**)
 See chart for more

MOUNTING (OPTIONAL)

Default is lay-In (-0),
 no need to specify
 Lay-In (default) **-0**
 Screw Holes in Face **-3**
 Concealed **-4**

NECK DIMENSIONS

In Inches
 6" **06**
 8" **08**
 10" **10**
 12" **12**
 14" **14**

DIRECTION (OPTIONAL)

1 Baffle **-A1**
 2 Corner Baffles **-AC**
 2 Opposed Baffles **-AO**
 3 Baffles **-A3**
 4 Baffles **-A4**

NECK DIMENSIONS

In Inches
 6" x 6" **0606**
 9" x 9" **0909**
 12" x 12" **1212**
 15" x 15" **1515**
 18" x 18" **1818**

INSULATION (OPTIONAL)

Default is uninsulated,
 no need to specify
 R4.2 Taped Insulation **-R4**
 R6 Taped Insulation **-R6**

FACE DIMENSIONS

12" x 24" **-Y1224**
 24" x 12" **-Y2412**
 24" x 24" **-Y2424**
 24" x 48" **-Y2448**
 48" x 24" **-Y4824**
 20" x 20" **-Y2020**

OPTION

Square equalizing grid **-ES**

SQUARE DIFFUSERS



MODELS ISO, ISOD, ISOI ARCHITECTURAL PLAQUE DIFFUSERS

MODEL **ISO** - Round neck

MODEL **ISOD** - 2" high collar, single-box

MODEL **ISOI** - R6 Insulated - Pre-scored for collars

ISO Series supply diffusers are recommended for heating, ventilating and cooling.

The ISO series provide a 360° air diffusion pattern similar to a full round diffuser. High diffusion induction rates result in rapid temperature and velocity equalization of the mixed air mass well above the zone of occupancy. Horizontal performance assures confident use of cooling temperature differential of 30°F and greater, at predicted low air motion 35 fpm in the zone of occupancy. ISO Series supply diffusers perform efficiently with air loadings of 6 to 30 air changes per hour (based on 10 ft. ceiling height), and sound level range of NC 25 to 35.

Features:

- Full face 24" x 24" for all neck sizes.
- Full face 12" x 12" for 6" & 8" neck sizes.
- Heavy-gauge all-steel construction.
- Ideal for VAV systems.
- Powder paint coating - White (default) Custom colours avail.
- Matching OBD dampers, NBI baffle, and PF plaster frame available.

ISO Model Size	Neck Dia	Nominal Face Size	Overall Face Size B x B	Drywall Ceiling Opening
1206	6	12 x 12	11 ³ / ₄ x 11 ³ / ₄	10 ¹ / ₂ x 10 ¹ / ₂
1208	8	12 x 12	11 ³ / ₄ x 11 ³ / ₄	10 ¹ / ₂ x 10 ¹ / ₂
2406	6	24 x 24	23 ³ / ₄ x 23 ³ / ₄	22 ¹ / ₂ x 22 ¹ / ₂
2408	8	24 x 24	23 ³ / ₄ x 23 ³ / ₄	22 ¹ / ₂ x 22 ¹ / ₂
2410	10	24 x 24	23 ³ / ₄ x 23 ³ / ₄	22 ¹ / ₂ x 22 ¹ / ₂
2412	12	24 x 24	23 ³ / ₄ x 23 ³ / ₄	22 ¹ / ₂ x 22 ¹ / ₂
2414	14	24 x 24	23 ³ / ₄ x 23 ³ / ₄	22 ¹ / ₂ x 22 ¹ / ₂

Model	Nominal Face Size	Overall Face Size B x B
ISOI	24 x 24	23 ³ / ₄ x 23 ³ / ₄



ISOI fiberglass back.



ISO

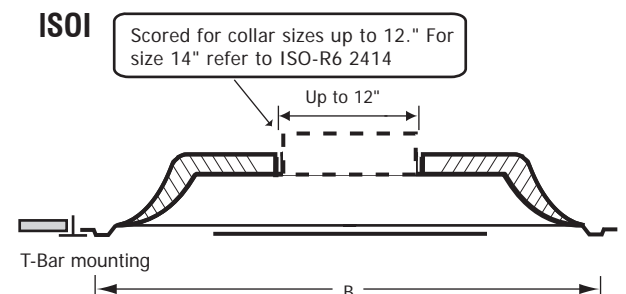
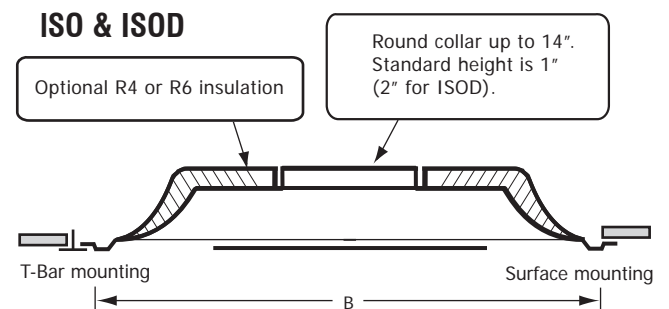
Highlights:

- **ISO** model suits both T-Bar and Drywall installation using rigid ducts
- Removable core for access to optional damper

Insulation:

ISO & ISOD - Optional R4 or R6 insulation. R6 fiberglass insulation complies with A.S.T.M. E84 flame and smoke test. Only available on models with 24" x 24" face.

ISOI - R6 fiberglass insulation.



PERFORMANCE DATA

SERIES ISO

PLAQUE DIFFUSERS



12" x 12" face

SIZE (inches)	Neck Velocity (fpm)	400	500	600	700	800	1000	1200	1400	1600
	Velocity Pressure (in H ₂ O)	.010	.016	.022	.031	.041	.062	.090	.122	.160
6	CFM	78	98	118	137	157	196	235	274	313
	Total Pressure	.05	.07	.10	.14	.18	.29	.41	.58	.72
	NC	< 20	< 20	< 20	< 20	< 20	21	24	29	37
	Throw (ft)	2-3-6	3-4-7	4-5-9	4-5-10	5-6-11	6-8-12	7-9-13	8-10-15	9-11-16
8	CFM	140	175	209	244	279	349	419	489	559
	Total Pressure	.07	.10	.15	.21	.29	.42	.62	.84	1.00
	NC	< 20	< 20	< 20	< 20	< 20	25	30	38	45
	Throw (ft)	2-4-7	3-5-9	4-7-10	5-8-11	6-9-12	7-10-14	8-12-17	10-12-18	11-14-20

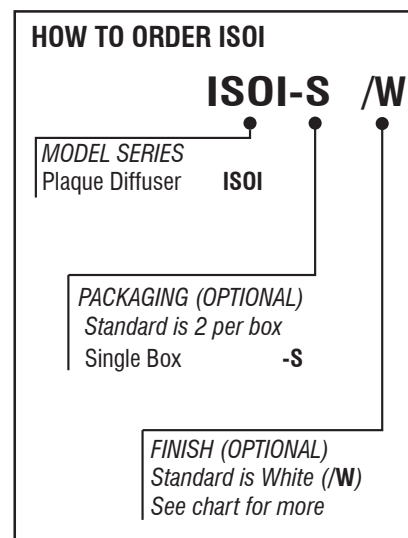
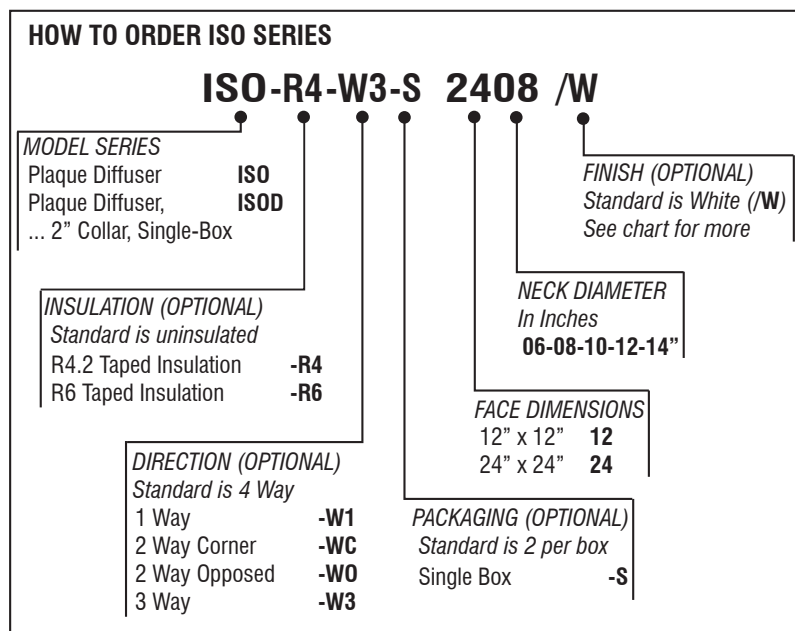
24" x 24" face

SIZE (inches)	Neck Velocity (fpm)	400	500	600	700	800	1000	1200	1400	1600
	Velocity Pressure (in H ₂ O)	.010	.016	.022	.031	.041	.062	.090	.122	.160
6	CFM	78	98	118	137	157	196	235	274	313
	Total Pressure	.02	.03	.04	.05	.08	.1	.14	.19	.24
	NC	< 20	< 20	< 20	< 20	< 20	23	27	32	37
	Throw (ft)	1-2-4	2-3-4	2-3-5	2-3-6	3-4-7	4-5-8	4-6-9	4-7-10	6-8-14
8	CFM	140	175	209	244	279	349	419	489	559
	Total Pressure	.02	.03	.04	.06	.08	.11	.17	.23	.29
	NC	< 20	< 20	< 20	< 20	< 20	28	32	36	41
	Throw (ft)	2-3-5	2-3-7	3-4-8	3-5-8	4-6-9	5-7-11	6-8-14	7-9-14	7-10-14
10	CFM	218	273	327	382	436	545	654	763	872
	Total Pressure	.03	.04	.06	.08	.11	.18	.24	.35	.48
	NC	< 20	< 20	< 20	< 20	23	29	36	40	44
	Throw (ft)	3-4-6	4-5-8	4-6-10	5-7-12	6-8-14	7-9-15	8-11-16	9-12-17	10-13-19
12	CFM	314	393	471	550	628	785	941	1099	1246
	Total Pressure	.04	.06	.08	.13	.16	.25	.35	.50	.67
	NC	< 20	< 20	< 20	21	24	31	38	43	47
	Throw (ft)	4-5-9	5-6-10	6-7-10	6-8-13	7-9-15	8-11-18	10-13-20	11-15-21	12-16-22
14	CFM	492	615	738	861	984	1230	1476	1722	1968
	Total Pressure	.05	.08	.13	.16	.22	.32	.43	.59	.80
	NC	< 20	< 20	< 20	22	27	34	40	43	47
	Throw (ft)	4-6-10	5-6-11	6-8-14	7-10-16	8-11-18	10-14-20	12-15-22	12-17-23	14-19-24

NC Value based on 10 db room attenuation.

Throw Values are based on isothermal air and terminal velocities of 150 fpm, 100 fpm & 75 fpm respectively.

Total Pressure the sum of static pressure plus velocity pressure and is given in inches w.g.



MODELS LRMF-LRIF-LRTF

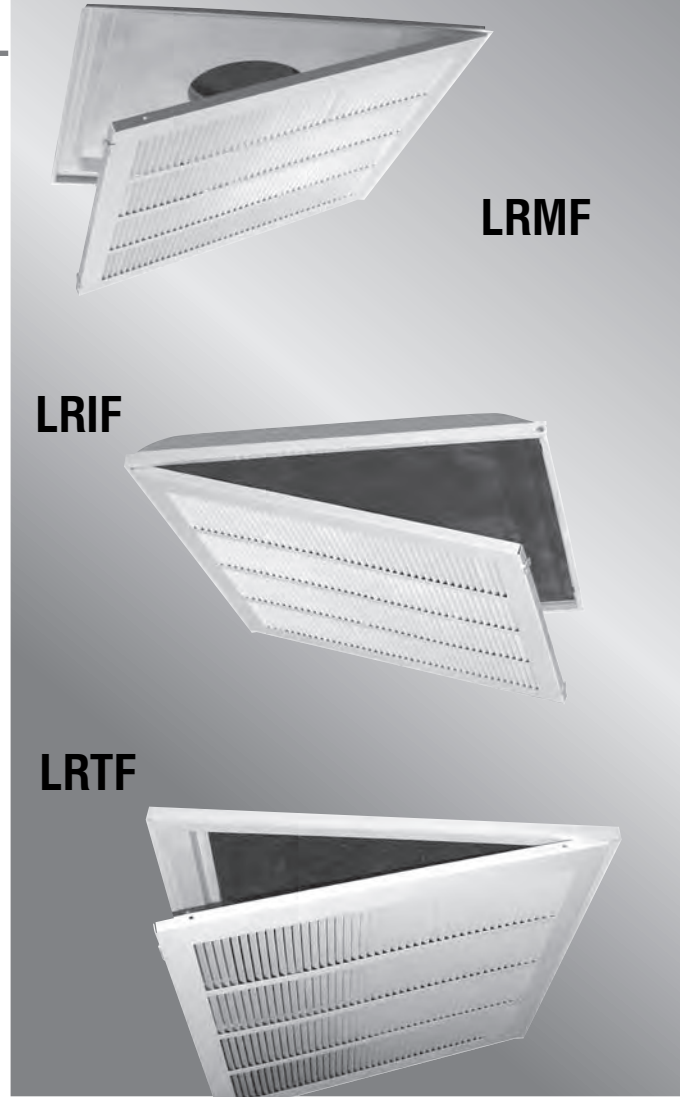
FOR TEE BAR LAY-IN INSTALLATIONS

Series **LR** filter grilles have their face lanced with rows of fins capable of transferring or returning high air volumes with minimum air pressure loss. The fins are set at 40° and spaced 1/2" apart. The face swings in or out of the fixed back pan for easy access to the 1" standard filter or filter media (supplied by others). Two locking arms opposite to the two concealed hinges provide secure locking of the face in an unobtrusive manner.

Model **LRMF** has steel back pan with heavy gauge steel reinforcing corners equivalent to 18 ga. so as to minimize damage due to handling.

Model **LRIF** has an insulated back pan consisting of a fixed extruded aluminum frame and a molded fiberglass pan suitable for round duct connections up to 14" D. and scored for easy cutting of collar opening. This model has sturdy corners so as to minimize damage due to handling.

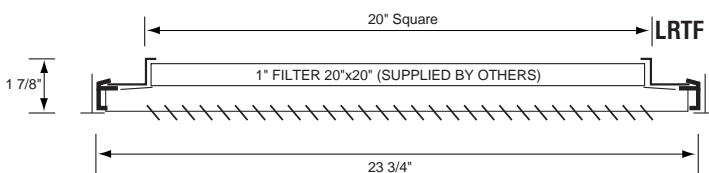
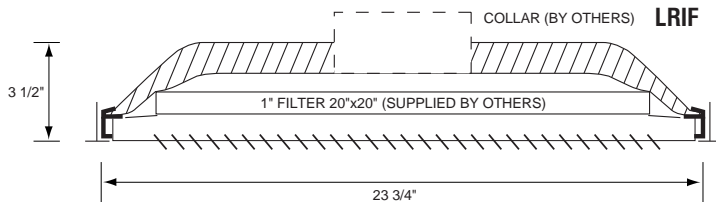
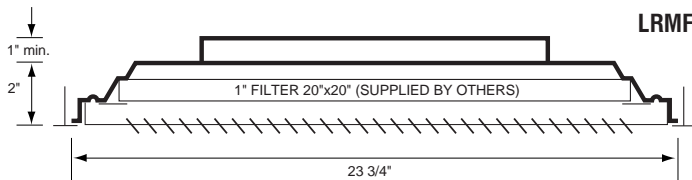
Model **LRTF** has a square filter frame to accommodate 20" x 20" filters and ducts of the same listed size. This model has sturdy corners so as to minimize damage due to handling.



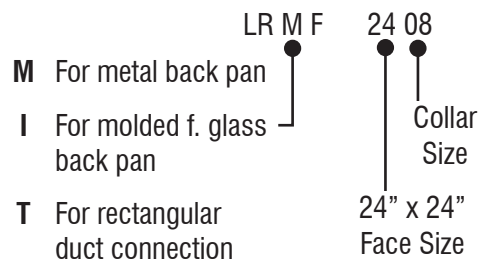
LRMF

LRIF

LRTF



HOW TO ORDER



MODELS PRMF-PRIF-PRTF

FOR TEE BAR LAY-IN INSTALLATIONS

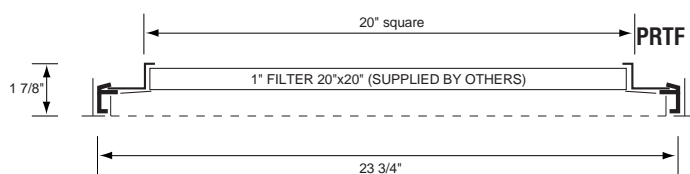
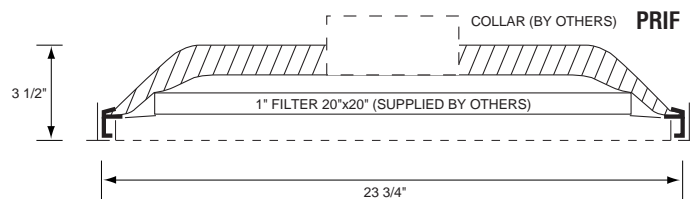
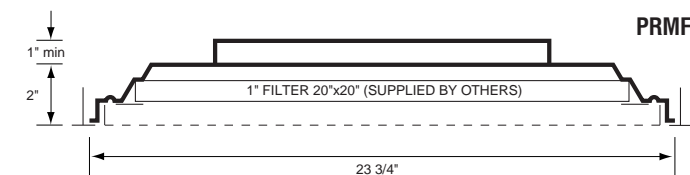
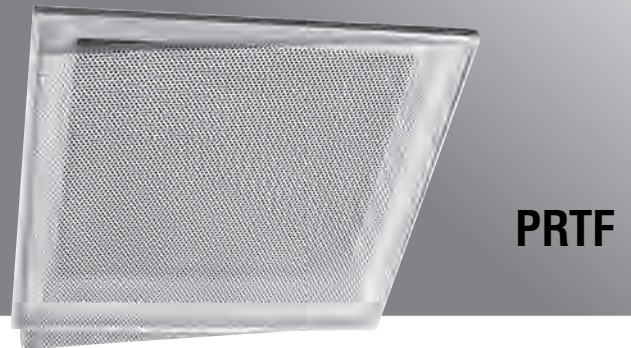
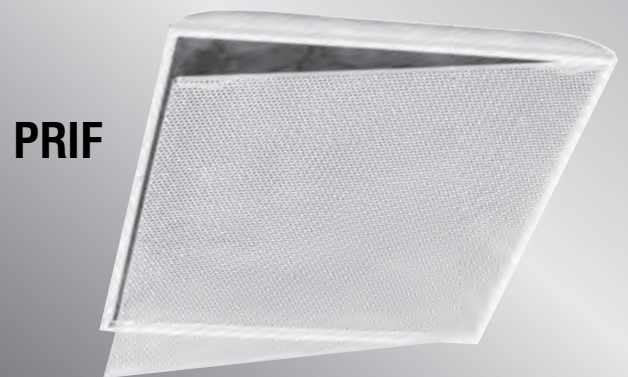
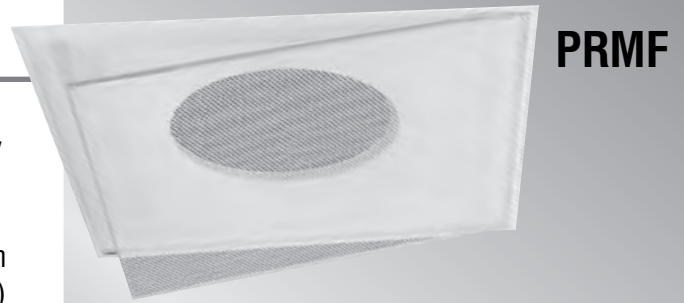
Series **PR** filter grilles match in appearance perforated face supply diffusers series PS.

The grille consists of a heavy gauge steel perforated face with 3/16" D. round holes on 1/4" staggered centers (53% free area) which swings in or out of the fixed back pan for easy access to the 1" filter 20" x 20" (supplied by others). Two locking arms opposite to the two concealed hinges provide secure locking of the grille in an unobtrusive manner.

Model **PRMF** has steel back pan with 20" x 20" square filter frame, heavy gauge steel reinforcing corners equivalent to 18 ga. so as to minimize damage due to handling. Extruded round collars will accommodate ducts 6", 8", 10", 12" & 14" D.

Model **PRIF** has an insulated back pan consisting of a fixed extruded aluminum frame and a molded fiberglass pan suitable for round ducts connections up to 14" D. and scored for easy cutting of collar opening. The extruded aluminum frame has sturdy corners so as to minimize damage due to handling.

Model **PRTF** has a square filter frame to accommodate 1" filters 20" x 20" and ducts of same listed size. The extruded aluminum frame has sturdy corners so as to minimize damage due to handling.



HOW TO ORDER

- M** For metal back pan
 - I** For molded f. glass back pan
 - T** For rectangular duct connection
- PRMF**
- 24 08
 - Collar Size
 - 24" x 24" Face Size

DATA SHEET

PERFORATED DIFFUSERS



MODELS PSI , PSIL & PRI with R6 Plenum

MODELS PSI & PSIL - Supply Diffusers

PSI Supply Diffusers have high diffusion induction rates resulting in rapid temperature and velocity equalization of the mixed air mass well above the zone of occupancy.

The horizontal performance of their air pattern baffle or optional directional louvers ensure confident use of cooling differentials of 25° F and greater, at predicted low air motion 35 fpm in the zone of occupancy.

PSI Supply Diffusers perform efficiently with air loadings of 1 to 3 cfm per square feet of floor area, or 6 to 20 air changes per hour (based on 10 ft. ceiling height) and sound level range of NC 25 to 35.



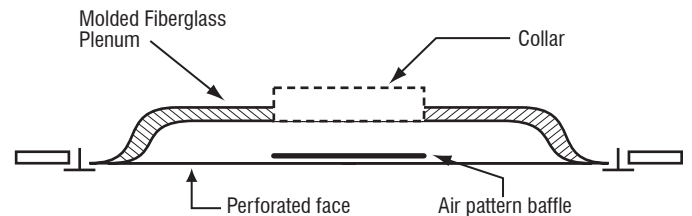
**PSI
PSIL
PRI**

MODEL PRI - Return Diffusers

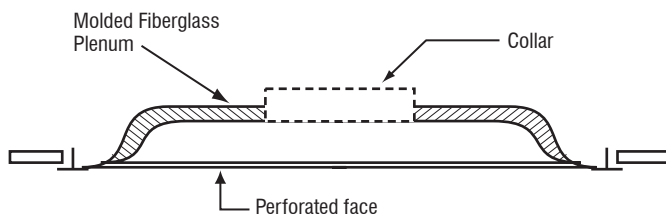
PRI Return Diffusers are similar to PSI but with the air pattern baffle removed. They are matched in appearance.

FEATURES

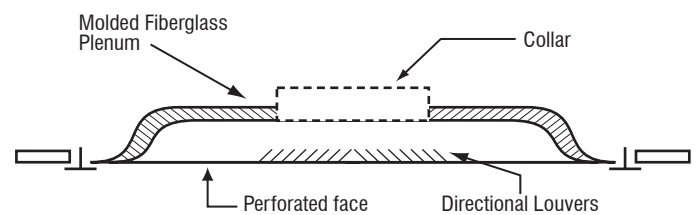
- Heavy gauge all steel construction.
- 24" X 24" face for neck sizes 6"-8"-10"-12"-14" D.
- Compatible with VAV Systems.
- Powder paint coating - White.
- Holes are 3/16" D. staggered 1/4" affording 53% free area.



Model PSI Standard - with Air Pattern Baffle



Model PRI - No Baffle



Model PSIL - with Directional Louvers

HOW TO ORDER

	PSI	/W
<i>MODEL SERIES</i>		
Supply - Round Baffle	PSI	<i>FINISH (OPTIONAL)</i>
Supply - Directional Baffles	PSIL	<i>Standard is White (/W)</i>
Return	PRI	<i>See chart for more</i>

ENGINEERING PERFORMANCE DATA

PERFORATED



MODEL PSI & PSIL - Supply Diffusers

24" x 24" face

NECK SIZE	Neck Velocity (fpm)	400	500	600	700	800	1000	1200	1400
	Velocity Pressure (in H ₂ O)	.010	.016	.022	.031	.041	.062	.090	.122
6"	CFM	78	98	118	137	157	196	235	274
	Total Pressure	.017	.027	.038	.053	.069	.109	.159	.215
	NC	< 20	< 20	< 20	21	27	32	37	41
	Throw (ft)	1-2-3	1-2-4	2-3-5	2-3-6	2-4-7	3-5-8	4-6-9	5-7-10
8"	CFM	140	175	209	244	279	349	419	489
	Total Pressure	.018	.028	.040	.054	.071	.109	.160	.216
	NC	< 20	< 20	< 20	24	27	33	37	42
	Throw (ft)	1-3-5	2-3-6	2-4-7	3-5-8	4-6-10	5-8-12	6-9-14	7-10-15
10"	CFM	218	273	327	382	436	545	654	763
	Total Pressure	.018	.026	.039	.054	.071	.109	.160	.216
	NC	< 20	< 20	< 20	23	28	36	41	47
	Throw (ft)	2-4-6	3-4-7	3-5-8	4-7-10	5-8-12	5-9-14	6-11-16	7-13-18
12"	CFM	314	393	471	550	628	785	941	1099
	Total Pressure	.019	.029	.041	.057	.072	.111	.163	.218
	NC	< 20	< 20	20	25	30	39	43	49
	Throw (ft)	2-5-7	3-5-8	3-7-10	4-8-12	5-9-14	7-11-16	8-12-18	10-14-21
14"	CFM	492	615	738	861	984	1230	1476	1722
	Total Pressure	.021	.032	.043	.075	.092	.141	.193	.261
	NC	< 20	< 20	21	26	34	40	45	50
	Throw (ft)	3-6-9	4-7-10	4-8-12	5-9-13	6-10-15	8-12-18	10-14-21	12-17-24

NC Value based on 10 db room attenuation.

Throw Values are based on isothermal air and thermal velocities of 150 fpm, 100 fpm & 75 fpm respectively.
Total Pressure the sum of static pressure plus velocity pressure and is given in inches w.g.

MODEL PRI - Return Diffusers

24" x 24" face

NECK SIZE	Neck Velocity (fpm)	400	500	600	700	800	1000	1200	1400
	Velocity Pressure (in H ₂ O)	0.010	0.015	0.022	0.031	0.040	0.062	0.090	0.122
	Static Pressure (in H ₂ O)	-0.026	-0.042	-0.060	-0.078	-0.104	-0.160	-0.212	-0.290
6"	CFM	78	98	118	137	157	196	235	274
	NC	< 20	< 20	< 20	< 20	< 20	20	23	26
8"	CFM	140	175	209	244	279	349	419	489
	NC	< 20	< 20	< 20	21	22	24	27	29
10"	CFM	218	273	327	382	436	545	654	763
	NC	< 20	< 20	21	23	25	28	30	32
12"	CFM	314	393	471	550	628	785	941	1099
	NC	< 20	20	24	26	28	31	34	36
14"	CFM	430	534	642	748	858	1072	1286	1500
	NC	22	25	28	30	32	35	37	39
16"	CFM	558	698	836	978	1110	1390	1666	1950
	NC	26	28	30	34	37	40	43	46

PERFORATED DIFFUSERS



MODELS PSM, PSML & PRM with Metal Plenum

MODELS PSM & PSML - Supply Diffusers

PSM Supply Diffusers have high diffusion induction rates resulting in rapid temperature and velocity equalization of the mixed air mass well above the zone of occupancy.

The horizontal performance of their standard air pattern baffle or optional directional louvers ensure confident use of cooling differentials of 25°F and greater at predicted low air motion 35 fpm in the zone of occupancy.

PSM Supply diffusers perform efficiently with air loadings of 1 to 3 cfm per square feet of floor area, or 6 to 20 air changes per hour (based on 10 ft. ceiling height) and sound level range of NC 25 to 35.



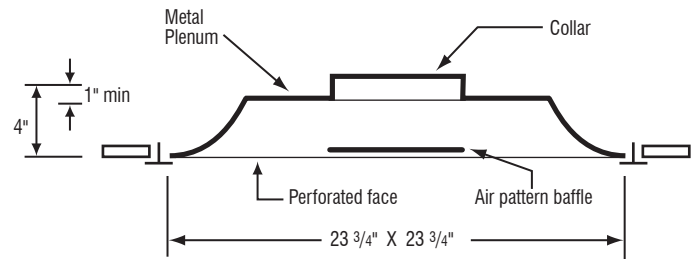
PSM
PSML
PRM

MODEL PRM - Return Diffusers

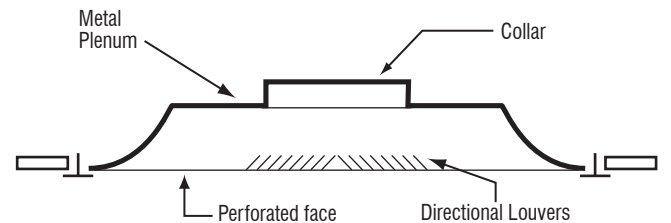
PRM Return Diffusers are similar to PSM but with the air pattern baffle removed. They are matched in appearance.

FEATURES

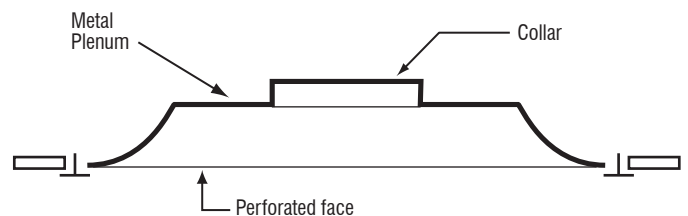
- Heavy gauge all steel construction.
- 24" X 24" face for neck sizes 6"-8"-10"-12"-14" D.
- Compatible with VAV Systems.
- Powder paint coating - White.
- Holes are 3/16" D. staggered 1/4" affording 53% free area.



Model PSM - with Air Pattern Baffle



Model PSML - with Directional Louvers



Model PRM - No Baffles

HOW TO ORDER PSM SERIES

PSM-R4-S 2408 /W

MODEL SERIES	PSM	FINISH (OPTIONAL) Standard is White (/W) See chart for more
Supply - Round Baffle	PSML	
Supply - Directional Baffles	PRM	
Return		

INSULATION (OPTIONAL)		NECK DIAMETER
Standard is uninsulated		In Inches
R4.2 Taped Insulation	-R4	06-08-10-12-14"
R6 Taped Insulation	-R6	

FACE DIMENSIONS
24" x 24" 24

PACKAGING (OPTIONAL)
Standard is 2 per box
Single Box -S

ENGINEERING PERFORMANCE DATA



MODEL PSM - Supply Diffusers

24" x 24" face

NECK SIZE	Neck Velocity (fpm)	400	500	600	700	800	1000	1200	1400
	Velocity Pressure (in H ₂ O)	.010	.016	.022	.031	.041	.062	.090	.122
6"	CFM	78	98	118	137	157	196	235	274
	Total Pressure	.017	.027	.038	.053	.069	.109	.159	.215
	NC	< 20	< 20	< 20	21	27	32	37	41
	Throw (ft)	1-2-3	1-2-4	2-3-5	2-3-6	2-4-7	3-5-8	4-6-9	5-7-10
8"	CFM	140	175	209	244	279	349	419	489
	Total Pressure	.018	.028	.040	.054	.071	.109	.160	.216
	NC	< 20	< 20	< 20	24	27	33	37	42
	Throw (ft)	1-3-5	2-3-6	2-4-7	3-5-8	4-6-10	5-8-12	6-9-14	7-10-15
10"	CFM	218	273	327	382	436	545	654	763
	Total Pressure	.018	.026	.039	.054	.071	.109	.160	.216
	NC	< 20	< 20	< 20	23	28	36	41	47
	Throw (ft)	2-4-6	3-4-7	3-5-8	4-7-10	5-8-12	5-9-14	6-11-16	7-13-18
12"	CFM	314	393	471	550	628	785	941	1099
	Total Pressure	.019	.029	.041	.057	.072	.111	.163	.218
	NC	< 20	< 20	20	25	30	39	43	49
	Throw (ft)	2-5-7	3-5-8	3-7-10	4-8-12	5-9-14	7-11-16	8-12-18	10-14-21
14"	CFM	492	615	738	861	984	1230	1476	1722
	Total Pressure	.021	.032	.043	.075	.092	.141	.193	.261
	NC	< 20	< 20	21	26	34	40	45	50
	Throw (ft)	3-6-9	4-7-10	4-8-12	5-9-13	6-10-15	8-12-18	10-14-21	12-17-24

NC Value based on 10 db room attenuation.

Throw Values are based on isothermal air and terminal velocities of 150 fpm, 100 fpm & 75 fpm respectively.
Total Pressure the sum of static pressure plus velocity pressure and is given in inches w.g.

MODEL PRM - Return Diffusers

24" x 24" face

NECK SIZE	Neck Velocity (fpm)	400	500	600	700	800	1000	1200	1400
	Velocity Pressure (in H ₂ O)	0.010	0.015	0.022	0.031	0.040	0.062	0.090	0.122
	Static Pressure (in H ₂ O)	-0.026	-0.042	-0.060	-0.078	-0.104	-0.160	-0.212	-0.290
6"	CFM	78	98	118	137	157	196	235	274
	NC	< 20	< 20	< 20	< 20	< 20	20	23	26
8"	CFM	140	175	209	244	279	349	419	489
	NC	< 20	< 20	< 20	21	22	24	27	29
10"	CFM	218	273	327	382	436	545	654	763
	NC	< 20	< 20	21	23	25	28	30	32
12"	CFM	314	393	471	550	628	785	941	1099
	NC	< 20	20	24	26	28	31	34	36
14"	CFM	430	534	642	748	858	1072	1286	1500
	NC	22	25	28	30	32	35	37	39
16"	CFM	558	698	836	978	1110	1390	1666	1950
	NC	26	28	30	34	37	40	43	46

ENGINEERING PERFORMANCE DATA



MODEL PST - Supply Diffusers

24" x 24" face

NECK SIZE	Neck Velocity (fpm)	400	500	600	700	800	1000	1200	1400
	Velocity Pressure (in H ₂ O)	.010	.016	.022	.031	.041	.062	.090	.122
8 x 8"	CFM	198	222	267	311	356	444	593	682
	Total Pressure	.018	.026	.039	.054	.071	.109	.160	.216
	NC	< 20	< 20	< 20	23	28	36	41	47
	Throw (ft)	2-4-6	3-4-7	3-5-8	4-7-10	5-8-12	5-9-14	6-11-16	7-13-18
10 x 10"	CFM	278	347	417	486	556	625	822	972
	Total Pressure	.019	.029	.041	.057	.072	.111	.163	.218
	NC	< 20	< 20	20	25	30	39	43	49
	Throw (ft)	2-5-7	3-5-8	3-7-10	4-8-12	5-9-14	7-11-16	8-12-18	10-14-21
12 x 12"	CFM	400	500	600	700	800	1000	1200	1400
	Total Pressure	.021	.032	.043	.075	.092	.141	.193	.261
	NC	< 20	< 20	21	26	34	40	45	50
	Throw (ft)	3-6-9	4-7-10	4-8-12	5-9-13	6-10-15	8-12-18	10-14-21	12-17-24
14 x 14"	CFM	544	680	817	953	1088	1360	1633	1405
	Total Pressure	.023	.034	.092	.078	.096	.149	.201	.272
	NC	< 20	20	23	27	36	43	49	47
	Throw (ft)	4-7-11	5-9-12	5-9-14	6-10-14	7-11-16	9-13-20	12-16-24	14-20-27

MODEL PRT- Return Diffusers

24" x 24" face

NECK SIZE	Neck Velocity (fpm)	400	500	600	700	800	1000	1200	1400
	Velocity Pressure (in H ₂ O)	0.010	0.015	0.022	0.031	0.040	0.062	0.090	0.122
	Static Pressure (in H ₂ O)	-0.026	-0.042	-0.060	-0.078	-0.104	-0.160	-0.212	-0.290
12 x 12"	CFM	430	534	642	748	858	1072	1286	1500
	NC	22	25	26	28	32	35	37	39
14 x 14"	CFM	558	698	836	978	1110	1390	1666	1950
	NC	24	26	28	29	30	38	40	42
16 x 16"	CFM	712	961	1156	1345	1448	1932	2320	270
	NC	26	28	30	32	34	40	43	46
18 x 18"	CFM	900	1125	1350	1575	1700	2250	2700	3150
	NC	27	29	30	35	38	41	44	47

Exclusive Warranty for Airvector® Aluminum and Powder Coated Steel Grilles, Registers & Diffusers

Limited Warranty - Airvector® for aluminum or powder coated steel grilles, registers and diffusers.

Alfa Mega Inc. manufacturer of Airvector® products warrants to the owners of Airvector® products that, should rust become visible on the exposed portion of Airvector® aluminum or powder coated steel grilles, registers or diffusers, Airvector® will replace the rusted product. This warranty does not cover products affected by accidental or intentional damages, chemicals or misuse, including, without limitation, failure to perform necessary and reasonable maintenance.

The rusted unit must be shipped by the owner at its cost to Airvector® for replacement. Airvector® will cover the cost of replacement, including the cost of shipment back to the owner. Airvector® will not cover other charges, including costs of removal, handling or installation. A reasonable time should be allowed for replacement of the rusted unit. In case of a discontinued product, Airvector® will replace it with its closest equivalent.

This warranty is for five (5) years from the date of the shipment by Airvector®. This is the only warranty given with the purchase. Any warranties implied by law are limited to sixty (60) months from the date of shipment by Airvector®. Airvector® neither assumes nor authorizes any person or entity to assume for it any other liability in connection with any product covered by this agreement.

No payment or other compensation will be made for indirect or consequential damage such as, damage or injury to person or property or loss of revenue or profit which might be paid, incurred or sustained by reason of the use of inability to use a Airvector® product, even if such loss or damage could have been foreseen by Airvector®.

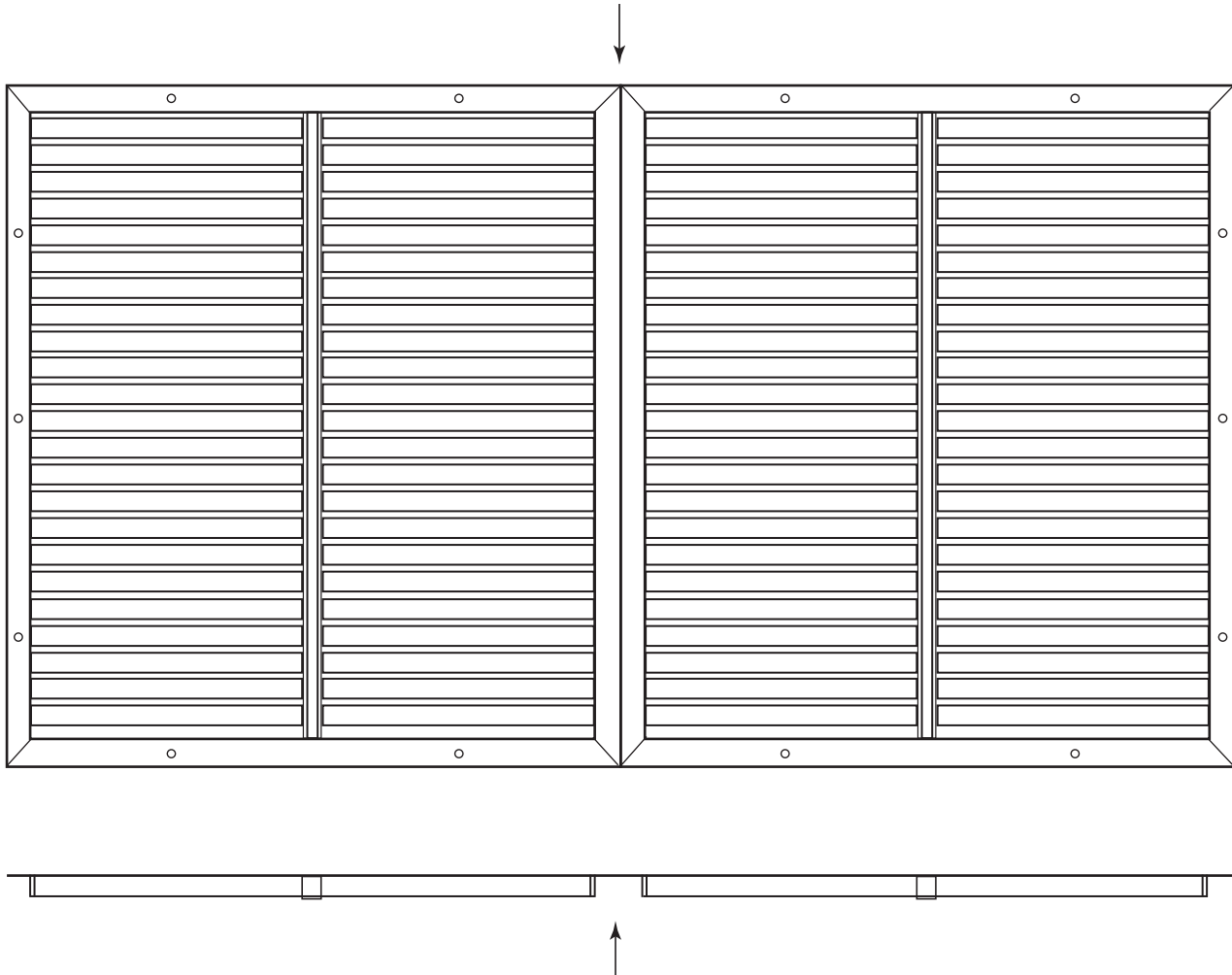
This warranty gives you specific legal rights and you may also have other rights which vary from state to state.

Some states do not allow the exclusion of limitation of incidental or consequential damages or limitation on how long an implied warranty lasts, so the above may not apply to you.



Large Grilles in Multiple Sections

No screw holes on interior joined frames by default
Screw holes can be added if clearly specified on order



Support required for proper installation by others
Not provided by Airvector

Notes

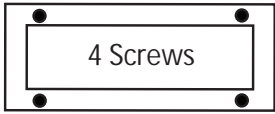
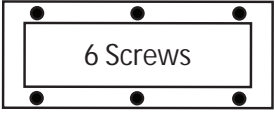

- Maximum section size: 46" x 36" (neck)
- Maximum width without mullion: 18"
- Larger grilles can be made in one piece, extra manufacturing and shipping charges apply

GRILLES SCREW HOLES CHART

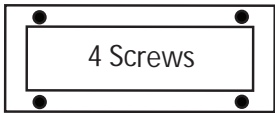
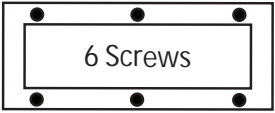
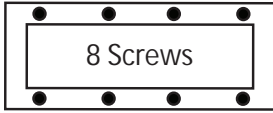
IGSA / GAA / ERE - Screw Holes Chart

		Width			
		4" to 17.9"	18" to 29.9"	30" to 47.9"	48" +
Height	4" to 17.9"	<p>2 Screws</p> <p>10" to 16" 10" to 16" 4 Screws</p>	<p>4 Screws</p>	<p>6 Screws</p>	<p>8 Screws</p>
	18" to 21.9"	<p>4 Screws</p>	<p>6 Screws</p>	<p>8 Screws</p>	<p>10 Screws</p>
	22" to 29.9"	<p>4 Screws</p>	<p>8 Screws</p>	<p>10 Screws</p>	<p>12 Screws</p>
	30" to 47.9"	<p>6 Screws</p>	<p>10 Screws</p>	<p>12 Screws</p>	<p>14 Screws</p>
	48" +	<p>8 Screws</p>	<p>12 Screws</p>	<p>14 Screws</p>	<p>16 Screws</p>

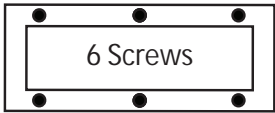
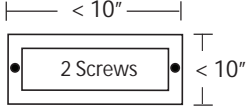
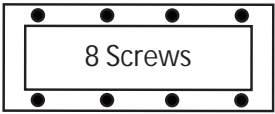
ALS - Architectural Linear Slot Diffusers

		Lenght		
		4" to 36"	37" to 48"	49" to 72"
Nb. of Slots	1 - 10			
		4 Screws	6 Screws	8 Screws

ALF - Linear Flow Airflow Diffusers

		Lenght		
		4" to 36"	37" to 48"	49" to 72"
Nb. of Slots	1 - 10			
		4 Screws	6 Screws	8 Screws

ALB - Architectural Linear Bar Grilles & Registers

		Lenght	
		18" to 36"	37" to 72"
Width	1.5" - 15"	 	
		6 Screws	8 Screws

The current chart features standard finishes offered by Airvector® on most products. Colors and textures have been reproduced as accurately as possible. However, due to variances among computer monitors and printers, the colors may appear differently than on the actual products. Some finishes might not apply to all products. Extra costs and lead times have been listed

to help you price and schedule your orders. See RAL available on our RAL K7 Classic Colour Chart. For more accurate costs and lead times, to confirm availability of a finish on a particular product or for custom finish requirements, please contact our customer service department at order@airvector-hvac.com.

Preview	Color Name	Code	Extra Cost	Lead Time
Powder Coated Paint	White Gloss level: low RAL: 9016	/W	Standard (no extra cost)	Standard 2 weeks Premium Services Available
	Silver Aluminum Gloss level: matte	/SI	15% - 20% adder	Standard 2 weeks Premium Services Available
	Off White Gloss level: medium RAL: 9010	/OW	15% - 20% adder	Standard 2 weeks Premium Services Available
	Beige Gloss level: high RAL: 1013	/BE	15% - 20% adder	Standard 2 weeks Premium Services Available
	Grey Gloss level: high	/G	15% - 20% adder	Standard 2 weeks Premium Services Available
	Brown Gloss level: matte	/BR	15% - 20% adder	Standard 2 weeks Premium Services Available
	Black Gloss level: medium	/BK	15% - 20% adder	Standard 2 weeks Premium Services Available
	Black Mat Gloss level: mat	/BM	15% - 20% adder	Standard 2 weeks Premium Services Available
	Brushed & Lacquered Gloss level: high	/L	15% - 35% adder	Standard 2 weeks Premium Services Available
	Colors from Tiger Drylac selection	/C	\$500 setup charge 15% - 35% adder	Minimum 4 weeks
Other Finishes	Mill (Raw Aluminum)	/M	Standard (no extra cost)	Standard 2 weeks Premium Services Available
	Anodized	/A	15% - 25% adder	Standard 2 weeks Premium Services Available
	Brushed Aluminum (No Lacquer)	/B	15% - 20% adder	Standard 2 weeks Premium Services Available

Commercial Air Distribution Products

Unique level of service, personalized and very helpful

Great standard lead times and premium services

High quality products with exclusive features



www.airvector-hvac.com