

Contact and update

Update

Updated Data Sheets and Submittals are available in PDF on our website at:

www.airvector-hvac.com

- Print them to update your catalog
- Email them to your customers

For Technical Questions

Email:

info@airvector-hvac.com

Phone:

1-866-AIRVECTOR ext 203
or
1-866-247-8328 ext 203

Fax

1-877-439-0671

Order Desk and Customer Service

Email:

order@airvector-hvac.com

Phone:

1-866-AIRVECTOR ext 201
or
11-866-247-8328 ext 201

Fax

1-877-439-0671



345 Montee-de-Liesse
Saint-Laurent, QC, H4T 1P5
Canada
Phone : 1-866-247-8328 (1-866-AIRVECTOR)
Fax : 1-877-439-0671

Submittal Drawings & Performance Data

Submittal Sheet	4	ALS3APL	50	ERE / ERE7	99	GPR	146
ADA3	4	ALS3PL	51	ERE1 / ERE17	100	GRT / GRT7	147
ADA3D	5	ASL4 / ALS47	52	ERE3 / ERE37	101	GRTI	148
ADA4	6	ALS4APL	53	ERE50 / ERE57	102	GRTS - GRTA	149
ADA4D	7	ALS4PL	54	ERI	103	GSA10 - GAA10	150
ADF3	8	ALS50 / ALS57	55	ERI5	104	GSA20 - GAA20	151
ADF3D	9	ALS5APL	56	ERIF	105	GSA40 - GAA40	152
ADF3I	10	ALS4PL	57	ERIF5	106	GSA4-GAA4-SF-3	153
ADF4	11	ALSD1	58	ERM	107	HI Option	154
ADF4D	12	ALSD2	59	ERM5	108	ICG	155
ADF4I	13	ALSD3	60	ERMF	109	ISA / ISA9	156
ADL10 / ADL17 / ADL18	14	ALSMC1	61	ERMF5	110	ISAI	157
ADLD10/ADLD17/ADLD18	15	ALSMC2	62	ERN	111	ISAM	158
ADSW	16	APRT	63	ERN1 / ERN3 / ERN5	112	ISO	159
ADSWD	17	APSM	64	ERN-P	113	ISOD	160
ADSWI	18	APSM L	65	ERT / ERT7	114	ISOI	161
ADTW	19	ARCH / ARCH7	66	ERT1 / ERT17	115	LA12	162
ADTWD	20	ARF1	67	ERT3 / ERT37	116	LA21	163
ADTWI	21	ARF2	68	ERT5 / ERT57	117	LA12	164
AISO	22	DA3	69	ERTF	118	LA21	165
AISOD	23	DA3D	70	ERTF5	119	LBP	166
AISOI	24	DA4	71	ERU / ERU7	120	LRIF	167
ALB ALS-SPECIAL SHAPE	25	DA4D	72	ERU1 / ERU17	121	LRMF	168
ALB10 / ALB17	26	DCG	73	ERU3 / ERU37	122	LRTF	169
ALB20 / ALB27	27	DDC	74	ERU5 / ERU57	123	MSA	170
ALB30 / ALB37	28	DDW	75	FERE	124	N2	171
ALB40 / ALB47	29	DF3	76	FERE5	125	N4	172
ALB50 / ALB57	30	DF3D	77	FERT	126	N5	173
ALB60 / ALB67	31	DF3I	78	FGAA	127	N7	174
ALB80 / ALB87	32	DF4	79	FGRT	128	N7-CO	175
ALB90 / ALB97	33	DF4D	80	FGRTI	129	N9	176
ALBCO	34	DF4I	81	FlexRight	130	NBD	177
ALF10 / ALF17 / ALF18	35	DHIR	82	FPRE	131	NBI	178
ALF1APL...	36	DHIS	83	GADA / GADS / GADC /		NCD	179
ALF1PL...	37	DKS1 / DKS2 / DKS3	84	GADS	132	NCO	180
ALF20 / ALF27 / ALF28	38	DLA / DLA9	85	GADF	133	NCR	181
ALF2APL...	39	DLA-HI / DLA9-HI	86	GAR1	134	NEG	182
ALF2PL	40	DLAI	87	GATS/GATD/GATA/GATN	135	NES	183
ALR	41	DLAM	88	GCB10 / GCB17	136	NR6MFG	184
ALS10 / ALS17	42	DLAM-HI	89	GCB20 / GCB27	137	NSA1	185
ALS1APL	43	DLV	90	GCB30 / GCB37	138	NSA3	186
ALS10/ALS17-L-SHAPE LIN-		DRC	91	GCB40 / GCB47	139	NT Accessory	187
EAR SLOT DIFFUSER	44	DRV	92	GDA10 / GDA17 / GDA18	140	NTQR	188
ALS1PL	45	DSW	93	GDA20 / GDA27 / GDA28		NTRR	189
ALS20 / ALS27	46	DSWD	94	141		NTQS	190
ALS2APL	47	DSWI	95	GDPA	142	NTSR	191
ALS2PL	48	DTW	96	GER	143	NTSS	192
ALS30 / ALS37	49	DTWD	97	GHA2	144	NVRPL	193
		DTWI	98	GPL	145	PADO	194

SUBMITTAL + DATA SHEET

Submittal Drawings & Performance Data

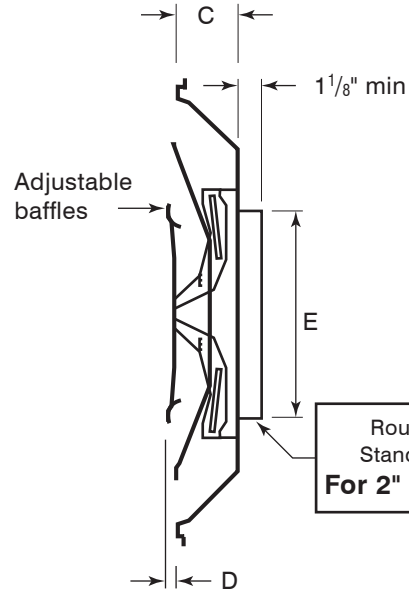
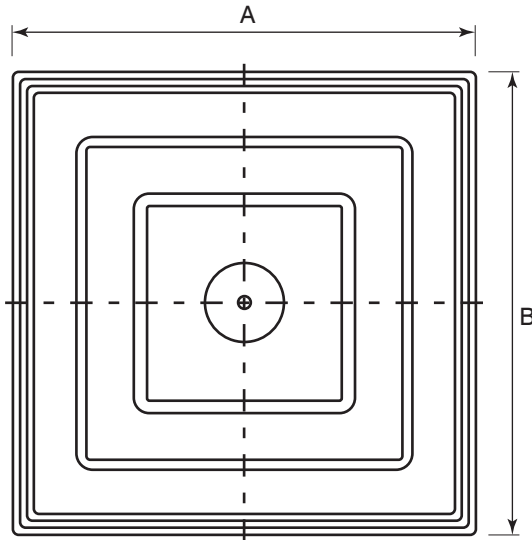
PADS	195	ARCH Series	281
PAHD	196	ARCH Series	283
PF	197	AVS Series	287
PRE / PRE7	198	DCG Series	288
PRI	199	DDC	292
PRM	200	DDO	294
PRMD	201	DDQ	297
PRMF	202	DDW	299
PRMFL	203	DF3 Series	302
PRN	204	DF4 Series	305
PRT	205	DLA Series	308
PRTF	206	DLA-HI Series	314
PSI	207	DLA-HI 4W	315
PSIF	208	DRV Series	316
PSIFL	209	DSW, DSWI	317
PSIL	210	DTW	319
PSM	211	ERx Series	321
PSMC	212	ERx Series	323
PSMD	213	ERxF Series	324
PSML	214	GADA / GADS / GADC	325
PST	215	GATS / GATA / GATD	326
PSTL	216	GCB Series	327
RAF / RAF7	217	GDA Series	329
RC1 / RC2 / RC3 / RC4	218	GDA Series	334
REAL / REAL7	219	GRT Series	339
RFB1	220	GSA, GAA Series	340
RFG	221	ICG Series	347
RR	222	ISA Series	349
RRF	223	ISO Series	353
RS1 / RS2 / RS3 / RS4	224	LRMF, LRIF, LRTF	356
RTF	225	PRE / PRE7, PRT / PRN	357
TUFL	226	PRMF, PRIF, PRTF	359
TUFP	227	PSI/PSIL/PRI	360
VADF	228	PSM, PSML, PRM	362
VAT	229	PST Series	364
VAV	230	Warranty	365
VDT	231		
VEV	232	Large Grilles in Multi- ple Sections	366
VSDF	233		
VSCDA	234	Sidewall Grilles Screw Holes Chart	367
VSDF	235		
XRE	236		
U option	237	Linear Grilles and Diffusers Screw Holes Chart	368
Data Sheet			
239		Finishes	369
ADF3, ADF3D, ADF3I	239		
ALB Series	248		
ALF Series	254		
ALS Series	270		

Aluminum Ceiling Supply Air Diffuser 3 Cone Adjustable

- Material:** Stamped heavy gauge aluminum.
- Finish:** Powder paint coating - white.
- Air Pattern:** Adjustable air pattern from horizontal for cooling to vertical for heating, full face.
- Safety:** Seismic tabs.
- Mounting:** Surface or lay-in T-bar ceiling.
- Core Removal:** Unlock hanger brackets by swiveling lever down. Holding cone L at opposite sides, push upwards, then turn clockwise and drop core free from back plenum.



ADA3
All Aluminum



Optional fiberglass insulation on back panel, complies with A.S.T.M. E84 flame and smoke test. (Available only on models with 24" x 24" face)

-R4 -R6

✓	Model #	Duct Size	Overall Face Dimension "A" x "B"	Depth Of Unit Dimension "C"	Exposed Depth Dimension "D"	Collar Diameter "E"
	ADA3 1206	6	11 3/4" x 11 3/4"	1 3/4"	7/16"	5 7/8"
	ADA3 1208	8	11 3/4" x 11 3/4"	1 3/4"	7/16"	7 7/8"
	ADA3 2406	6	23 3/4" x 23 3/4"	2 7/8"	7/8"	5 7/8"
	ADA3 2408	8	23 3/4" x 23 3/4"	2 7/8"	7/8"	7 7/8"
	ADA3 2410	10	23 3/4" x 23 3/4"	2 7/8"	7/8"	9 7/8"
	ADA3 2412	12	23 3/4" x 23 3/4"	2 7/8"	7/8"	11 7/8"
	ADA3 2414	14	23 3/4" x 23 3/4"	2 7/8"	7/8"	13 7/8"

Finish	
<input type="checkbox"/> /W White (Default)	<input type="checkbox"/> /C Custom (Please Specify)



Schedule type: _____

Job: _____

Architect: _____

Engineer: _____

Contractor: _____

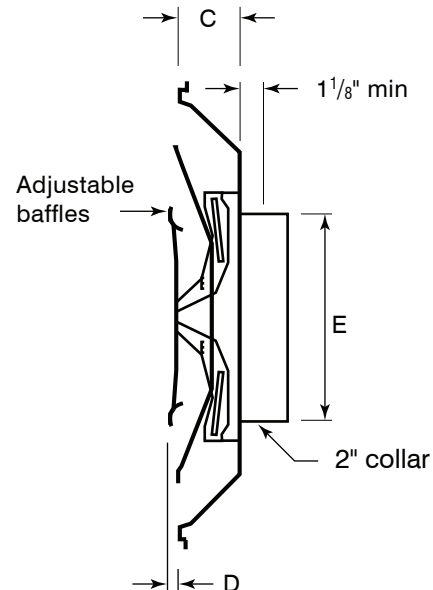
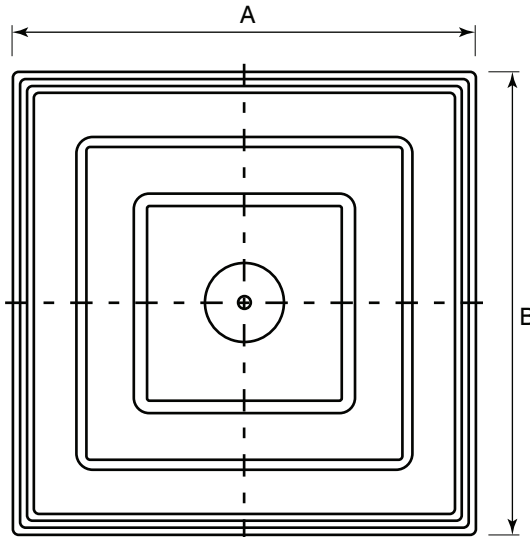
Aluminum Ceiling Supply Air Diffuser 3 Cone Adjustable - 2" High Collar

- Material:** Stamped heavy gauge aluminum.
Finish: Powder paint coating - white.
Air Pattern: Adjustable air pattern from horizontal for cooling to vertical for heating, full face.
Safety: Seismic tabs.
Mounting: Surface or lay-in T-bar ceiling.
Core Removal: Unlock hanger brackets by swiveling lever down. Holding cone L at opposite sides, push upwards, then turn clockwise and drop core free from back plenum.



ADA3D
All Aluminum

SUBMITTAL SHEET



Optional fiberglass insulation on back panel, complies with A.S.T.M. E84 flame and smoke test. (Available only on models with 24" x 24" face)

 -R4

 -R6

✓	Model #	Duct Size	Overall Face Dimension "A" x "B"	Depth Of Unit Dimension "C"	Exposed Depth Dimension "D"	Collar Diameter "E"
	ADA3D 1206	6	11 3/4" x 11 3/4"	1 3/4"	7/16"	5 7/8"
	ADA3D 1208	8	11 3/4" x 11 3/4"	1 3/4"	7/16"	7 7/8"
	ADA3D 2406	6	23 3/4" x 23 3/4"	2 7/8"	7/8"	5 7/8"
	ADA3D 2408	8	23 3/4" x 23 3/4"	2 7/8"	7/8"	7 7/8"
	ADA3D 2410	10	23 3/4" x 23 3/4"	2 7/8"	7/8"	9 7/8"
	ADA3D 2412	12	23 3/4" x 23 3/4"	2 7/8"	7/8"	11 7/8"
	ADA3D 2414	14	23 3/4" x 23 3/4"	2 7/8"	7/8"	13 7/8"

Finish	
<input type="checkbox"/> /W White (Default)	<input type="checkbox"/> /C Custom (Please Specify)



Schedule type: _____

Job: _____

Architect: _____

Engineer: _____

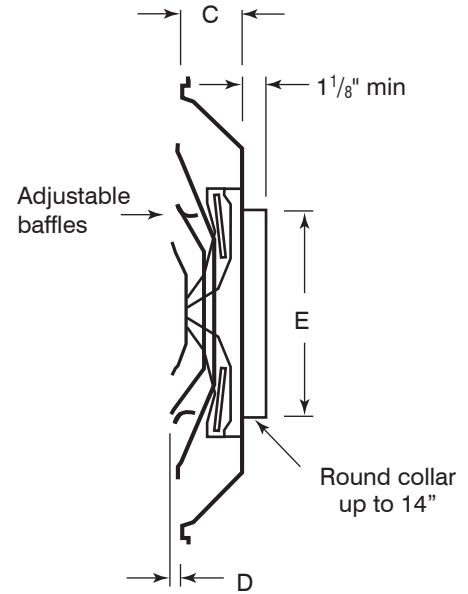
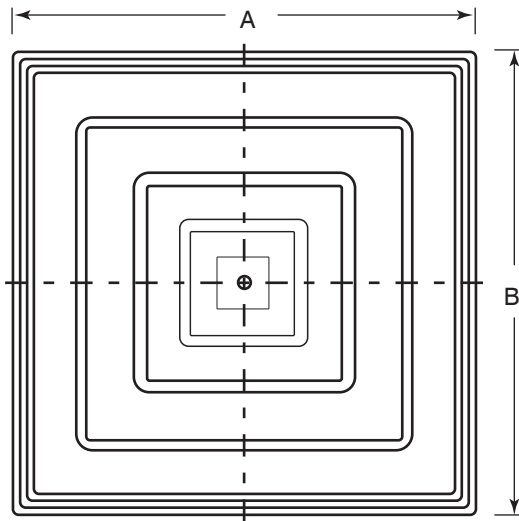
Contractor: _____

Aluminum Ceiling Supply Air Diffuser 4 Cone Adjustable

- Material:** Stamped heavy gauge aluminum.
- Finish:** Powder paint coating - white.
- Air Pattern:** Adjustable air pattern from horizontal for cooling to vertical for heating, full face.
- Safety:** Seismic tabs.
- Mounting:** Surface or lay-in T-bar ceiling.
- Core Removal:** Unlock hanger brackets by swiveling lever down. Holding cone L at opposite sides, push upwards, then turn clockwise and drop core free from back plenum.



ADA4
All Aluminum



Optional fiberglass insulation on back panel, complies with A.S.T.M. E84 flame and smoke test. (Available only on models with 24" x 24" face)

-R4 -R6

Finish	
<input type="checkbox"/> /W White (Default)	<input type="checkbox"/> /C Custom (Please Specify)



✓	Model #	Duct Size	Overall Face Dimension "A" x "B"	Depth Of Unit Dimension "C"	Exposed Depth Dimension "D"	Collar Diameter "E"
	ADA4 2406	6	23 3/4" x 23 3/4"	2 7/8"	7/8"	5 7/8"
	ADA4 2408	8	23 3/4" x 23 3/4"	2 7/8"	7/8"	7 7/8"
	ADA4 2410	10	23 3/4" x 23 3/4"	2 7/8"	7/8"	9 7/8"
	ADA4 2412	12	23 3/4" x 23 3/4"	2 7/8"	7/8"	11 7/8"
	ADA4 2414	14	23 3/4" x 23 3/4"	2 7/8"	7/8"	13 7/8"

Schedule type: _____

Job: _____

Architect: _____

Engineer: _____

Contractor: _____

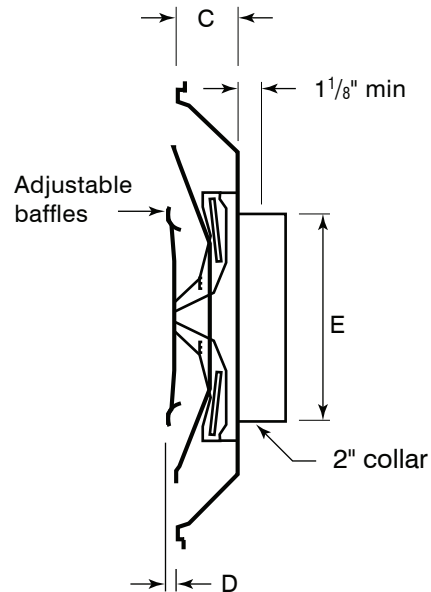
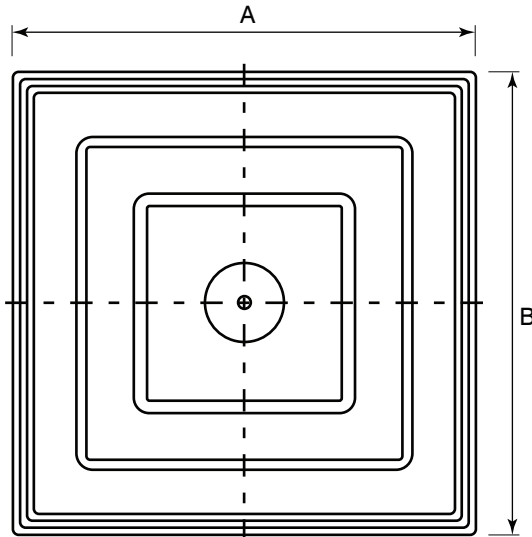
Aluminum Ceiling Supply Air Diffuser 4 Cone Adjustable - 2" High Collar

- Material:** Stamped heavy gauge aluminum.
Finish: Powder paint coating - white.
Air Pattern: Adjustable air pattern from horizontal for cooling to vertical for heating, full face.
Safety: Seismic tabs.
Mounting: Surface or lay-in T-bar ceiling.
Core Removal: Unlock hanger brackets by swiveling lever down. Holding cone L at opposite sides, push upwards, then turn clockwise and drop core free from back plenum.



ADA4D
All Aluminum

SUBMITTAL SHEET



Optional fiberglass insulation on back panel, complies with A.S.T.M. E84 flame and smoke test. (Available only on models with 24" x 24" face)



Finish	
<input type="checkbox"/> /W White (Default)	<input type="checkbox"/> /C Custom (Please Specify)



✓	Model #	Duct Size	Overall Face Dimension "A" x "B"	Depth Of Unit Dimension "C"	Exposed Depth Dimension "D"	Collar Diameter "E"
	ADA4D 2406	6	23 3/4" x 23 3/4"	2 7/8"	7/8"	5 7/8"
	ADA4D 2408	8	23 3/4" x 23 3/4"	2 7/8"	7/8"	7 7/8"
	ADA4D 2410	10	23 3/4" x 23 3/4"	2 7/8"	7/8"	9 7/8"
	ADA4D 2412	12	23 3/4" x 23 3/4"	2 7/8"	7/8"	11 7/8"
	ADA4D 2414	14	23 3/4" x 23 3/4"	2 7/8"	7/8"	13 7/8"

Schedule type: _____
 Job: _____
 Architect: _____
 Engineer: _____
 Contractor: _____

SUBMITTAL SHEET

Ceiling Square Diffuser - 3 Cone Fixed air pattern

- Material:** Stamped heavy gauge aluminum.
- Finish:** Powder paint coating - white.
- Air Pattern:** Fixed horizontal 360° diffusion.
- Safety:** Seismic tabs.
- Mounting:** Surface or Lay-in T-bar ceiling.
- Core Removal:** Unlock hanger brackets by swiveling lever down. Holding cone L at opposite sides, push upwards, then turn clockwise and drop core free from back plenum.

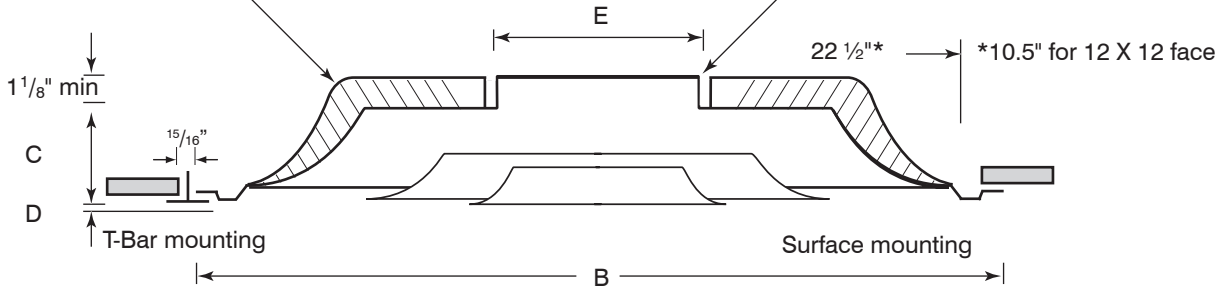


ADF3

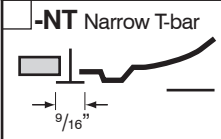
Optional fiberglass insulation on back panel, complies with A.S.T.M. E84 flame and smoke test. (Available only on models with 24" x 24" face)

- R4
- R6

Round collar up to 14".
Standard height is 1 1/8".
For 2" collar, see ADF3D



Mounting (Opt)



Round Collar Baffles

<input type="checkbox"/> W1 1 Way	<input type="checkbox"/> WC 2 Way Corner	<input type="checkbox"/> WO 2 Way Opposed	<input type="checkbox"/> W3 3 Way	<input type="checkbox"/> W4 4 Way (default)

Panel Option for T-bar lay-in Ceiling

	Steel (WxH)	Aluminum (WxH)
	<input type="checkbox"/> -X2412	<input type="checkbox"/> -Y2412
	<input type="checkbox"/> -X2424	<input type="checkbox"/> -Y2424
	<input type="checkbox"/> -X2448	<input type="checkbox"/> -Y2448
	<input type="checkbox"/> -X4824	<input type="checkbox"/> -Y4824
	<input type="checkbox"/> -X2020	<input type="checkbox"/> -Y2020

No fastening options available

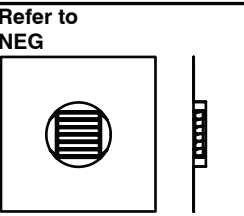
	Model #	Duct Size	E	Face Dim B x B	C	D
✓	ADF3 1206	6	5 7/8"	11 3/4" x 11 3/4"	1 3/4"	7/16"
	ADF3 1208	8	7 7/8"	11 3/4" x 11 3/4"	1 3/4"	7/16"
	ADF3 2406	6	5 7/8"	23 3/4" x 23 3/4"	2 7/8"	7/8"
	ADF3 2408	8	7 7/8"	23 3/4" x 23 3/4"	2 7/8"	7/8"
	ADF3 2410	10	9 7/8"	23 3/4" x 23 3/4"	2 7/8"	7/8"
	ADF3 2412	12	11 7/8"	23 3/4" x 23 3/4"	2 7/8"	7/8"
	ADF3 2414	14	13 7/8"	23 3/4" x 23 3/4"	2 7/8"	7/8"

Finish

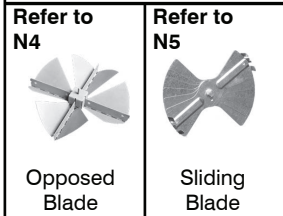
<input type="checkbox"/> /W White (Default)	<input type="checkbox"/> Custom (Please Specify)
--	--



Equalizing Grid (Option)



Damper (Option)



Plaster Frame (Option)



Schedule type: _____

Job: _____

Architect: _____

Engineer: _____

Contractor: _____

Aluminum Ceiling Square Diffuser 3 Cone - Fixed air pattern - 2" High Collar

Material: Stamped heavy gauge aluminium
Finish: Powder paint coating - white.
Air Pattern: Fixed horizontal 360° diffusion.
Safety: Seismic tabs.
Mounting: Surface or Lay-in T-bar ceiling.
 Unlock hanger brackets by swiveling lever down. Holding cone L at opposite sides, push upwards, then turn clockwise and drop core free from back plenum.

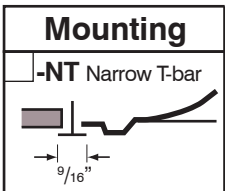
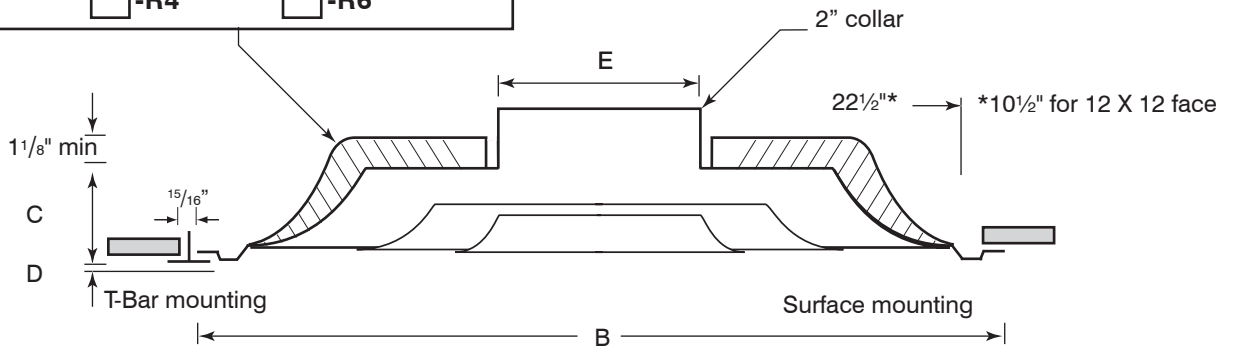


ADF3D
All Aluminum

SUBMITTAL SHEET

Optional fiberglass insulation on back panel, complies with A.S.T.M. E84 flame and smoke test. (Available only on models with 24" x 24" face)

-R4 -R6



Round Collar Baffles				
W1 1 Way	WC 2 Way Corner	WO 2 Way Opposed	W3 3 Way	W4 4 Way (default)

Panel Option for T-bar lay-in Ceiling		
W	Steel (WxH)	Aluminum (WxH)
	<input type="checkbox"/> -X2412	<input type="checkbox"/> -Y2412
	<input type="checkbox"/> -X2424	<input type="checkbox"/> -Y2424
	<input type="checkbox"/> -X2448	<input type="checkbox"/> -Y2448
	<input type="checkbox"/> -X4824	<input type="checkbox"/> -Y4824
	<input type="checkbox"/> -X2020	<input type="checkbox"/> -Y2020

No fastening options available

✓	Model #	Duct Size	E	Face Dim B x B	C	D
	ADF3D 1206	6	5 7/8"	11 3/4" x 11 3/4"	1 3/4"	7/16"
	ADF3D 1208	8	7 7/8"	11 3/4" x 11 3/4"	1 3/4"	7/16"
	ADF3D 2406	6	5 7/8"	23 3/4" x 23 3/4"	2 5/16"	1 3/8"
	ADF3D 2408	8	7 7/8"	23 3/4" x 23 3/4"	2 5/16"	1 3/8"
	ADF3D 2410	10	9 7/8"	23 3/4" x 23 3/4"	2 5/16"	1 3/8"
	ADF3D 2412	12	11 7/8"	23 3/4" x 23 3/4"	2 5/16"	1 3/8"
	ADF3D 2414	14	11 7/8"	23 3/4" x 23 3/4"	2 5/16"	1 3/8"

Finish

/W White (Default) /C Custom (Please Specify)



Equalizing Grid (Option)	Damper (Option)		Plaster Frame (Option)
Refer to NEG 	Refer to N4 Opposed Blade	Refer to N5 Sliding Blade	Refer to PF

Schedule type: _____

Job: _____

Architect: _____

Engineer: _____

Contractor: _____

SUBMITTAL SHEET

Aluminum Ceiling Square Diffuser 4 Cone - Fixed air pattern

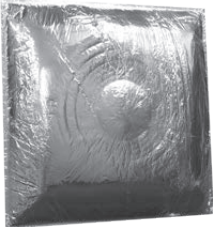
- Material:** Stamped heavy gauge aluminium.
- Finish:** Powder paint coating - white.
- Air Pattern:** Fixed horizontal 360° diffusion.
- Safety:** Seismic tabs.
- Mounting:** Lay-in T-bar ceiling.
- Core Removal:** Unlock hanger brackets by swiveling lever down. Holding cone L at opposite sides, push upwards, then turn clockwise and drop core free from back plenum.

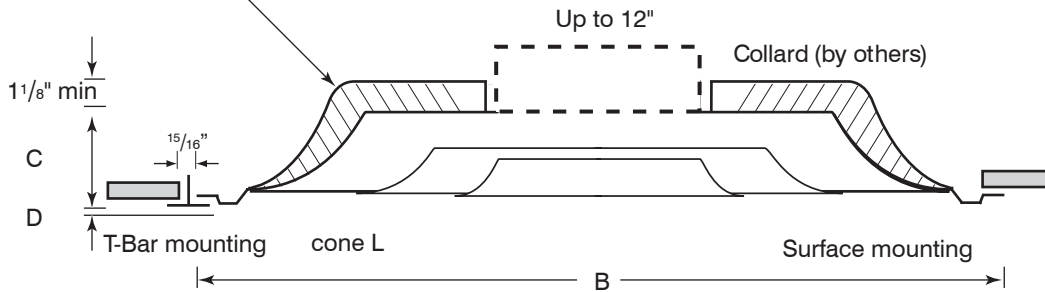


ADF3I

NR6MFG fiberglass back complies with A.S.T.M. E84 flame and smoke test.

Scored for collar sizes up to 12" D. Contractor to install job-specific collar in field. For size 14", please refer to model ADF3-R6 2414.





Model #	Face Dim B x B	C	D
ADF3I	23 3/4" X 23 3/4"	2 7/8"	7/8"

Finish	
<input type="checkbox"/> /W White (Default)	<input type="checkbox"/> /C Custom (Please Specify)



Schedule type: _____

Job: _____

Architect: _____

Engineer: _____

Contractor: _____

Ceiling Square Diffuser - 4 Cone Fixed air pattern

- Material:** Stamped heavy gauge aluminium.
Finish: Powder paint coating - white.
Air Pattern: Fixed horizontal 360° diffusion.
Safety: Seismic tabs.
Mounting: Surface or Lay-in T-bar ceiling.
 Unlock hanger brackets by swiveling lever down. Holding cone L at opposite sides, push upwards, then turn clockwise and drop core free from back plenum.



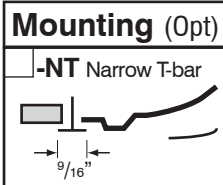
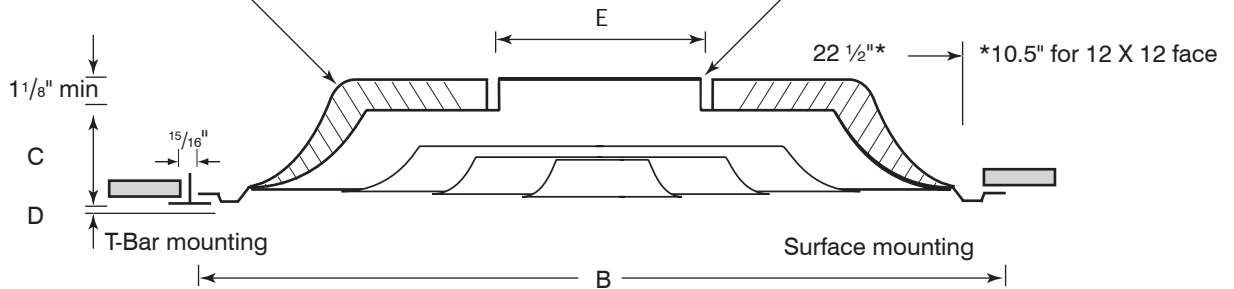
ADF4
All Aluminum

SUBMITTAL SHEET

Optional fiberglass insulation on back panel, complies with A.S.T.M. E84 flame and smoke test. (Available only on models with 24" x 24" face)

-R4 -R6

Round collar up to 14".
Standard height is 1 1/8".
For 2" collar, see ADF4D



Round Collar Baffles

<input type="checkbox"/> W1 1 Way	<input type="checkbox"/> WC 2 Way Corner	<input type="checkbox"/> WO 2 Way Opposed	<input type="checkbox"/> W3 3 Way	<input type="checkbox"/> W4 4 Way (default)

Panel Option for T-bar lay-in Ceiling

	Steel (WxH)	Aluminum (WxH)
	<input type="checkbox"/> -X2412	<input type="checkbox"/> -Y2412
	<input type="checkbox"/> -X2424	<input type="checkbox"/> -Y2424
	<input type="checkbox"/> -X2448	<input type="checkbox"/> -Y2448
	<input type="checkbox"/> -X4824	<input type="checkbox"/> -Y4824
	<input type="checkbox"/> -X2020	<input type="checkbox"/> -Y2020

No fastening options available

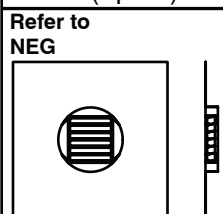
<input checked="" type="checkbox"/>	Model #	Duct Size	E	Face Dim B x B	C	D
	DF4 2406	6	5 7/8"	23 3/4" x 23 3/4"	2 7/8"	7/8"
	DF4 2408	8	7 7/8"	23 3/4" x 23 3/4"	2 7/8"	7/8"
	DF4 2410	10	9 7/8"	23 3/4" x 23 3/4"	2 7/8"	7/8"
	DF4 2412	12	11 7/8"	23 3/4" x 23 3/4"	2 7/8"	7/8"
	DF4 2414	14	13 7/8"	23 3/4" x 23 3/4"	2 7/8"	7/8"

Finish

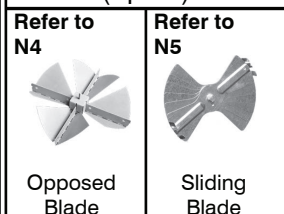
/W White (Default) /C Custom (Please Specify)



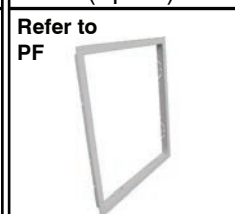
Equalizing Grid (Option)



Damper (Option)



Plaster Frame (Option)



Schedule type: _____
 Job: _____
 Architect: _____
 Engineer: _____
 Contractor: _____

SUBMITTAL SHEET

Aluminum Ceiling Square Diffuser 4 Cone - Fixed air pattern - 2" High Collar

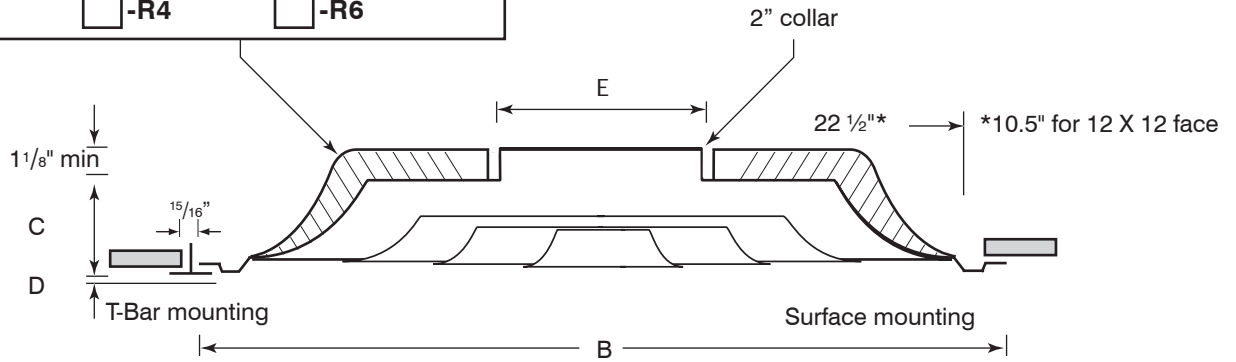
- Material:** Stamped heavy gauge steel.
- Finish:** Powder paint coating - white.
- Air Pattern:** Fixed horizontal 360° diffusion.
- Safety:** Seismic tabs.
- Mounting:** Surface or Lay-in T-bar ceiling.
Unlock hanger brackets by swiveling lever down. Holding cone L at opposite sides, push upwards, then turn clockwise and drop core free from back plenum.



ADF4D

Optional fiberglass insulation on back panel, complies with A.S.T.M. E84 flame and smoke test. (Available only on models with 24" x 24" face)

-R4 -R6



Mounting (Opt)

-NT Narrow T-bar

Round Collar Baffles

<input type="checkbox"/> W1 1 Way	<input type="checkbox"/> WC 2 Way Corner	<input type="checkbox"/> WO 2 Way Opposed	<input type="checkbox"/> W3 3 Way	<input type="checkbox"/> W4 4 Way (default)

Panel Option for T-bar lay-in Ceiling

Steel (WxH)	Aluminum (WxH)
<input type="checkbox"/> -X2412	<input type="checkbox"/> -Y2412
<input type="checkbox"/> -X2424	<input type="checkbox"/> -Y2424
<input type="checkbox"/> -X2448	<input type="checkbox"/> -Y2448
<input type="checkbox"/> -X4824	<input type="checkbox"/> -Y4824
<input type="checkbox"/> -X2020	<input type="checkbox"/> -Y2020

No fastening options available

✓	Model #	Duct Size	E	Face Dim B x B	C	D
	ADF4D 2406	6	5 7/8"	23 3/4" x 23 3/4"	2 5/16"	1 3/8"
	ADF4D 2408	8	7 7/8"	23 3/4" x 23 3/4"	2 5/16"	1 3/8"
	ADF4D 2410	10	9 7/8"	23 3/4" x 23 3/4"	2 5/16"	1 3/8"
	ADF4D 2412	12	11 7/8"	23 3/4" x 23 3/4"	2 5/16"	1 3/8"
	ADF4D 2414	14	11 7/8"	23 3/4" x 23 3/4"	2 5/16"	1 3/8"

Finish

/W White (Default) /C Custom (Please Specify)



Equalizing Grid (Option) Refer to NEG 	Damper (Option) Refer to N4 Opposed Blade Refer to N5 Sliding Blade	Plaster Frame (Option) Refer to PF
---	--	--

Schedule type: _____

Job: _____

Architect: _____

Engineer: _____

Contractor: _____

Aluminum Ceiling Square Diffuser 4 Cone - Fixed air pattern

- Material:** Stamped heavy gauge aluminium.
Finish: Powder paint coating - white.
Air Pattern: Fixed horizontal 360° diffusion.
Safety: Seismic tabs.
Mounting: Lay-in T-bar ceiling.
Core Removal: Unlock hanger brackets by swiveling lever down. Holding cone L at opposite sides, push upwards, then turn clockwise and drop core free from back plenum.

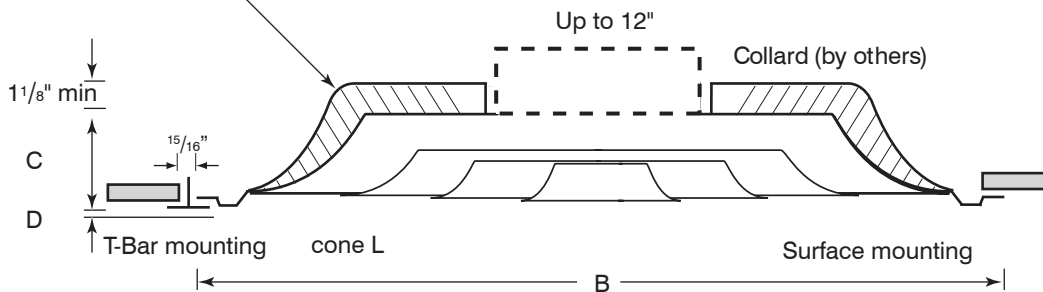


ADF4I
All Aluminum

SUBMITTAL SHEET

NR6MFG fiberglass back complies with A.S.T.M. E84 flame and smoke test.

Scored for collar sizes up to 12" D. Contractor to install job-specific collar in field. For size 14", please refer to model ADF4-R6 2414.



Model #	Face Dim B x B	C	D
ADF4I	23 3/4" X 23 3/4"	2 7/8"	7/8"

Finish	
<input type="checkbox"/> /W White (Default)	<input type="checkbox"/> /C Custom (Please Specify)



Schedule type: _____
 Job: _____
 Architect: _____
 Engineer: _____
 Contractor: _____

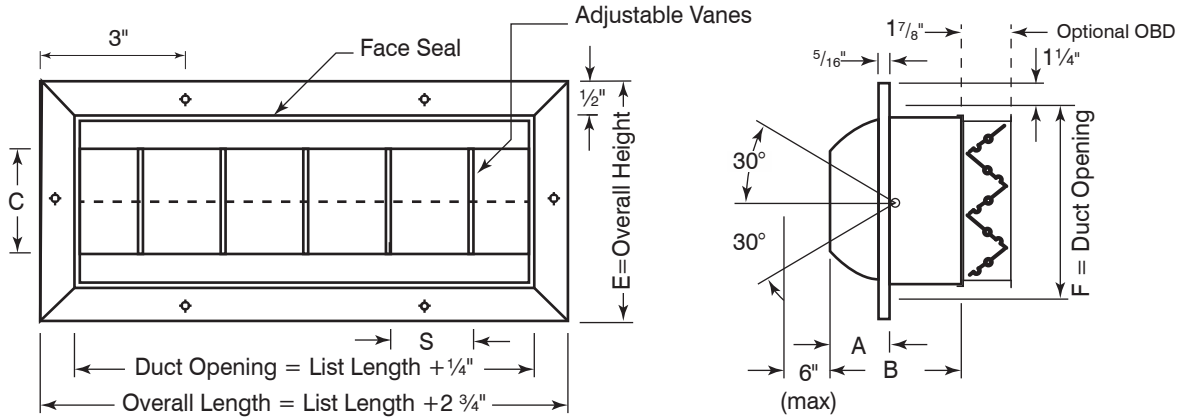
Drum Louver Standard Blades

Material: Extruded aluminum construction.
Mounting: Surface mount.



ADL10

- ADL10**
without damper
- ADL17**
with steel opposed blade damper
- ADL18**
with air scoop



Frame Gasket -GK

Vane Option	
<input type="checkbox"/> -SV Single Vane 	<input type="checkbox"/> -DV Double Vane

Fastening Method	
<input type="checkbox"/> -1 No Fastening 	<input type="checkbox"/> -3 Screw (default)

Option
<input type="checkbox"/> -GO Gang operator

Finish	
<input type="checkbox"/> /W White (Default)	<input type="checkbox"/> /C Custom (Please Specify)



✓	Available Height	A	B	C	E	F	S
	4"	1"	3 5/16"	2"	6 9/16"	5"	3"
	6"	1 13/16"	4 7/16"	3 5/8"	8 9/16"	7"	3"
	8"	2"	4 7/16"	4 1/2"	10 1/2"	9"	3"
	10"	2 11/16"	6"	6"	12 3/8"	10 3/4"	5"
	12"	3 1/8"	6"	6 1/4"	14"	12 9/16"	5"
	15"	3 5/8"	8 3/16"	9 3/8"	17"	15 9/16"	5"

Schedule type: _____

Job: _____

Architect: _____

Engineer: _____

Contractor: _____

Spiral-Duct Drum Louver Standard Blades

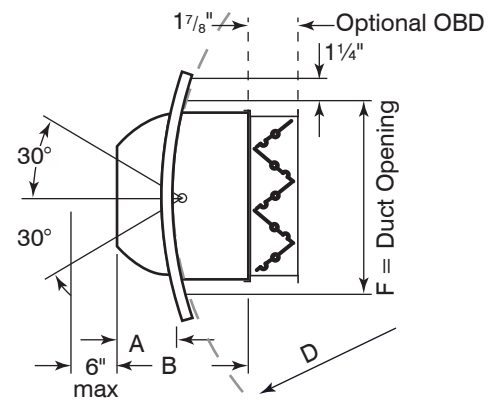
Material: Extruded aluminum construction.
Mounting: Round ducts mounted.
Finish: Powder paint coating - white.
Fastening Method: Countersunk mounting holes on frame.


ADLD

SUBMITTAL SHEET

- ADLD10**
 without damper
- ADLD17**
 with steel opposed blade damper
- ADLD18**
 with air scoop

Frame Gasket -GK



Duct D (in inches)	Duct Cut Out Opening			
	H = 6"	H = 10"	H = 12"	H = 15"
-D06				
-D08	6 ³ / ₄ "			
-D10	6 ¹ / ₄ "			
-D12	6 ¹ / ₄ "	11 ³ / ₄ "		
-D14	6 ¹ / ₄ "	11 ¹ / ₈ "	14 ³ / ₈ "	
-D16	6 ¹ / ₈ "	10 ³ / ₄ "	13 ¹ / ₄ "	
-D18	6 ¹ / ₈ "	10 ⁵ / ₈ "	13 ¹ / ₈ "	
-D20	6 ¹ / ₈ "	10 ¹ / ₄ "	12 ⁷ / ₈ "	
-D22	6 ¹ / ₈ "	10 ³ / ₈ "	12 ³ / ₄ "	
-D24	6"	10 ¹ / ₄ "	12 ¹ / ₄ "	
-D26	6"	10 ¹ / ₄ "	12 ¹ / ₄ "	
-D34	6"	10 ¹ / ₈ "	12 ¹ / ₄ "	
-D44	6"	10"	12 ¹ / ₈ "	
Over 64	6"	10"	12"	
Universal/Default Duct Diameter	-D14*	-D26*	-D26*	

Vane Option

<input type="checkbox"/> -SV Single Vane	<input type="checkbox"/> -DV Double Vane

Fastening Method

<input type="checkbox"/> -1 No Fastening	<input type="checkbox"/> -3 Screw

Option

-GO Gang operator

Finish

<input type="checkbox"/> /W White (Default)	<input type="checkbox"/> /C Custom (Please Specify)
---	--



✓	Available Height	A	B	C	E	F	S
	6"	1 ¹³ / ₁₆ "	4 ⁷ / ₁₆ "	3 ⁵ / ₈ "	8 ⁹ / ₁₆ "	7"	3"
	10"	2 ¹¹ / ₁₆ "	6"	6"	12 ³ / ₈ "	10 ³ / ₄ "	5"
	12"	3 ¹ / ₈ "	6"	6 ¹ / ₄ "	14"	12 ⁹ / ₁₆ "	5"
	15"	3 ⁵ / ₈ "	8 ³ / ₁₆ "	9 ³ / ₈ "	17"	15 ⁹ / ₁₆ "	5"

Schedule type: _____

Job: _____

Architect: _____

Engineer: _____

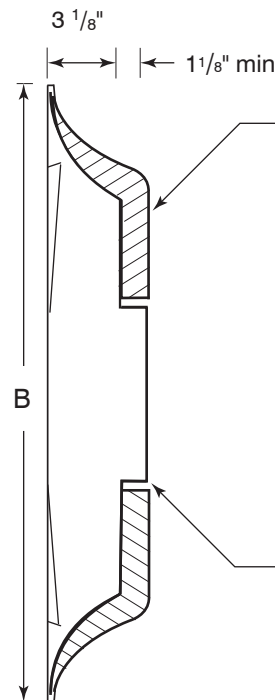
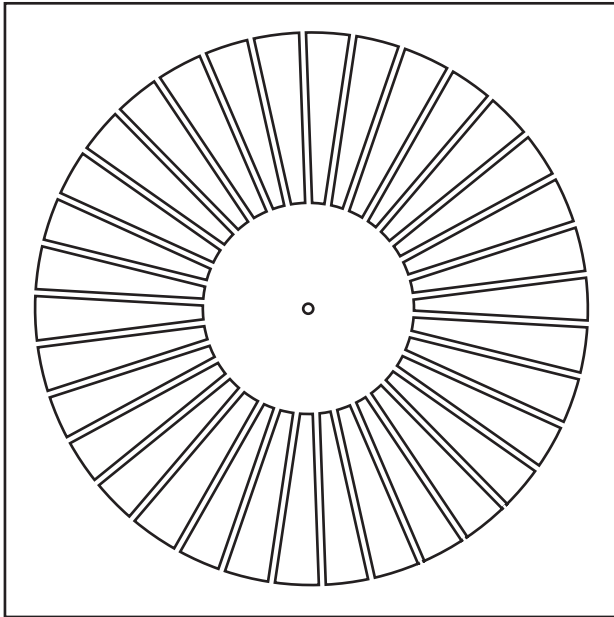
Contractor: _____

Swirl Face Supply Diffuser Fixed face

Material: Stamped heavy gauge aluminum.
Finish: Powder paint coating - white.
Air Pattern: Fixed 360° spiral pattern.
Mounting: Lay-in T-bar ceiling.



ADSW
All Aluminum



Optional fiberglass insulation on back panel, complies with A.S.T.M. E84 flame and smoke test. (Available only on models with 24" x 24" face)

-R4 -R6

Round collar up to 14".
Standard height is 1 1/8".
For 2" collar, see ADSWD

✓	Model #	Duct Size	Neck Size	Face Dim B x B
	ADSW 2406	6	5 7/8"	23 7/8" x 23 7/8"
	ADSW 2408	8	7 7/8"	23 7/8" x 23 7/8"
	ADSW 2410	10	9 7/8"	23 7/8" x 23 7/8"
	ADSW 2412	12	11 7/8"	23 7/8" x 23 7/8"
	ADSW 2414	14	13 7/8"	23 7/8" x 23 7/8"

Finish	
<input type="checkbox"/> /W White (Default)	<input type="checkbox"/> /C Custom (Please Specify)



Schedule type: _____

Job: _____

Architect: _____

Engineer: _____

Contractor: _____

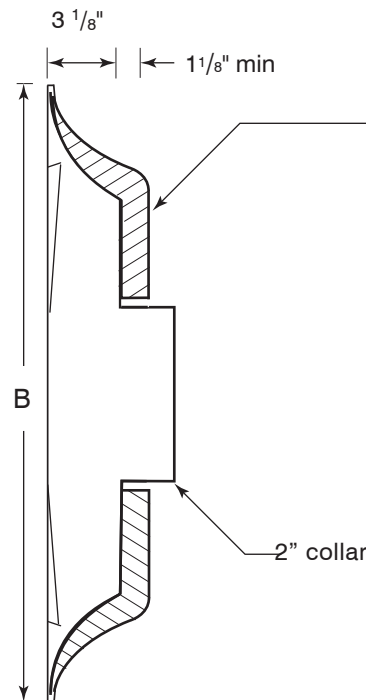
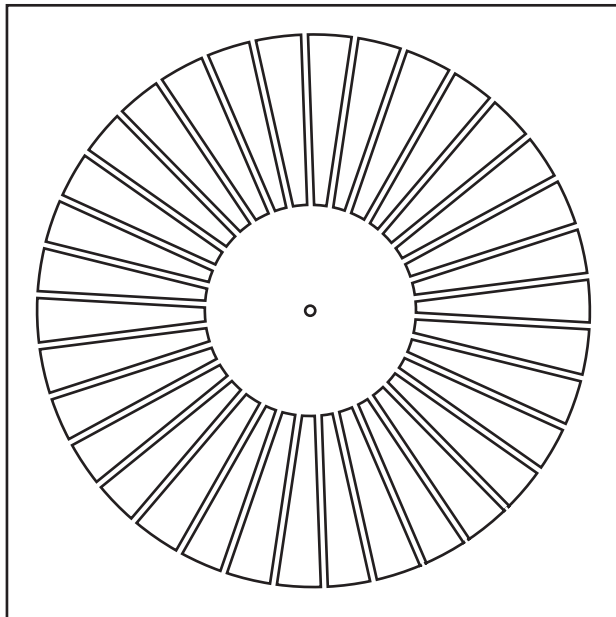
Swirl Face Supply Diffuser Fixed face - 2" Collar

Material: Stamped heavy gauge aluminum.
Finish: Powder paint coating - white.
Air Pattern: Fixed 360° spiral pattern.
Mounting: Lay-in T-bar ceiling.



SUBMITTAL SHEET

ADSWD
All Aluminum



Optional fiberglass insulation on back panel, complies with A.S.T.M. E84 flame and smoke test. (Available only on models with 24" x 24" face)



-R4



-R6

✓	Model #	Duct Size	Neck Size	Face Dim B x B
	ADSWD 2406	6	5 7/8"	23 7/8" x 23 7/8"
	ADSWD 2408	8	7 7/8"	23 7/8" x 23 7/8"
	ADSWD 2410	10	9 7/8"	23 7/8" x 23 7/8"
	ADSWD 2412	12	11 7/8"	23 7/8" x 23 7/8"
	ADSWD 2414	14	13 7/8"	23 7/8" x 23 7/8"

Finish	
<input type="checkbox"/> /W White (Default)	<input type="checkbox"/> /C Custom (Please Specify)



Schedule type: _____

Job: _____

Architect: _____

Engineer: _____

Contractor: _____

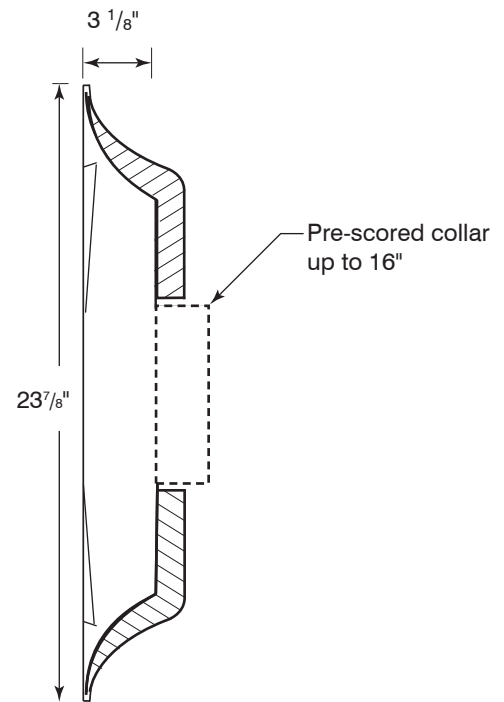
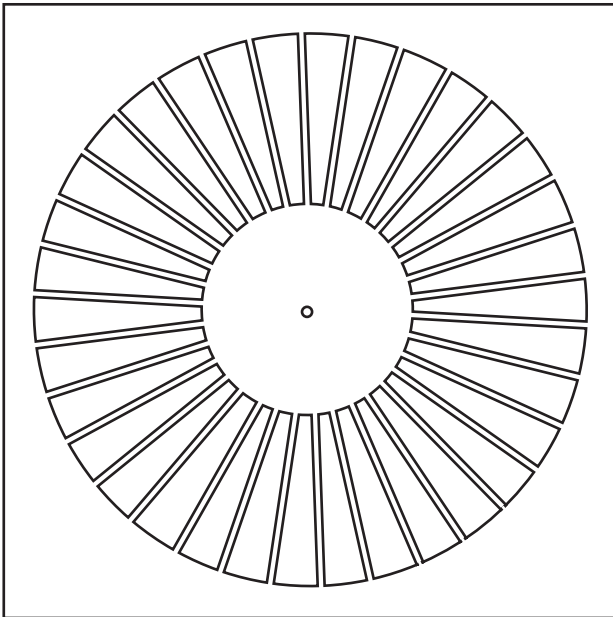
Swirl Face Supply Diffuser Fixed face

- Material:** Stamped heavy gauge aluminum back panel.
- Finish:** Powder paint coating - white.
- Air Pattern:** Fixed 360° spiral pattern.
- Mounting:** Lay-in T-bar ceiling.
- Insulation:** R6 Molded Fiberglass.



ADSWI
All Aluminum

Fiberglass back complies with
A.S.T.M. E84 flame and smoke test.
Scored for collar sizes up to 14" D.



Finish	
<input type="checkbox"/> /W White (Default)	<input type="checkbox"/> /C Custom (Please Specify)



Schedule type: _____

Job: _____

Architect: _____

Engineer: _____

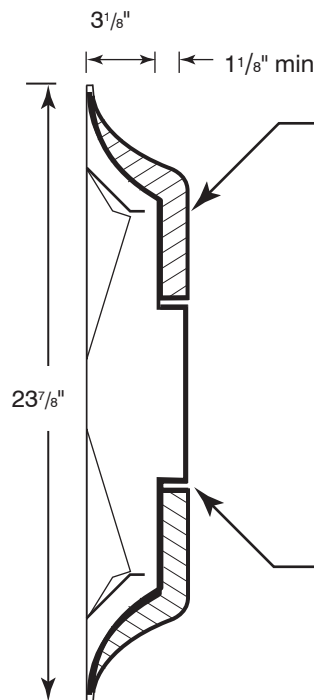
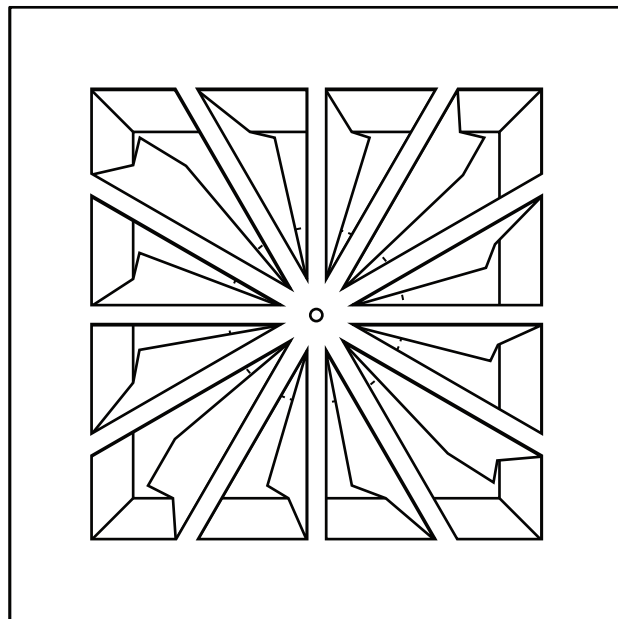
Contractor: _____

Stamped Twist Diffuser

- Finish:** Stamped heavy gauge aluminum.
Material: Powder paint coating - white.
Air Pattern: Fixed 360° spiral pattern.
Mounting: Lay-in T-bar ceiling.


ADTW

SUBMITTAL SHEET

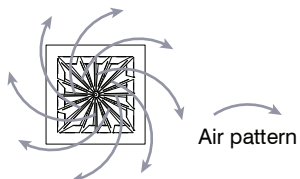


Optional fiberglass insulation on back panel, complies with A.S.T.M. E84 flame and smoke test. (Available only on models with 24" x 24" face)

-R4 -R6

Round collar. Standard height is 1 1/8". Other options available.

2" collar



✓	Model #	Duct Size	Neck Size	Face Dim B x B
	ADTW 2406	6	5 7/8"	23 7/8" x 23 7/8"
	ADTW 2408	8	7 7/8"	23 7/8" x 23 7/8"
	ADTW 2410	10	9 7/8"	23 7/8" x 23 7/8"
	ADTW 2412	12	11 7/8"	23 7/8" x 23 7/8"
	ADTW 2414	14	13 7/8"	23 7/8" x 23 7/8"

Finish	
<input type="checkbox"/> /W	<input type="checkbox"/> /C Custom (Please Specify)
White (Default)	_____



Schedule type: _____

Job: _____

Architect: _____

Engineer: _____

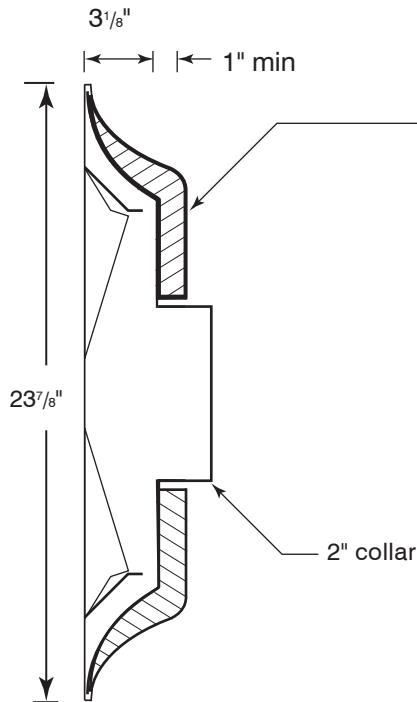
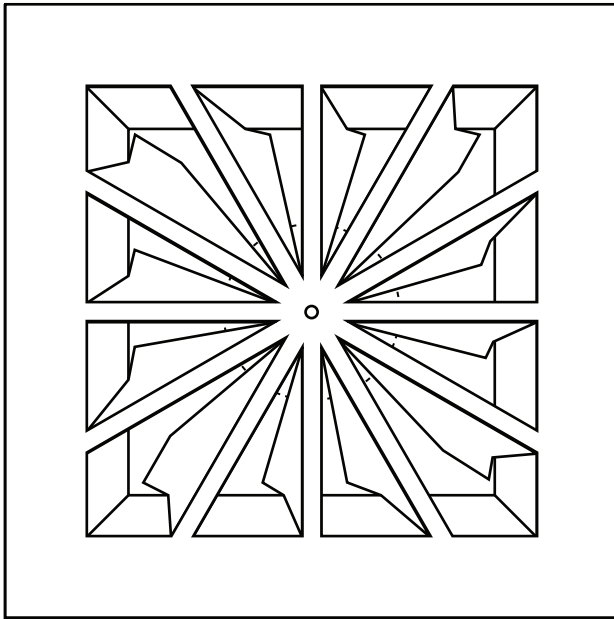
Contractor: _____

Stamped Twist Diffuser Fixed face - 2" Collar

Finish: Stamped heavy gauge aluminum.
Material: Powder paint coating - white.
Air Pattern: Fixed 360° spiral pattern.
Mounting: Lay-in T-bar ceiling.

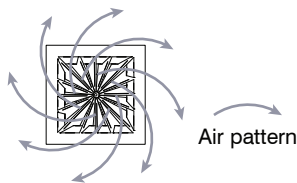


ADTWD



Optional fiberglass insulation on back panel, complies with A.S.T.M. E84 flame and smoke test. (Available only on models with 24" x 24" face)

-R4 -R6



Finish	
<input type="checkbox"/> /W White (Default)	<input type="checkbox"/> /C Custom (Please Specify)



Schedule type: _____

Job: _____

Architect: _____

Engineer: _____

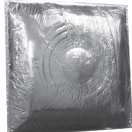
Contractor: _____

Stamped Twist Diffuser Fixed Face - Fiberglass Insulation

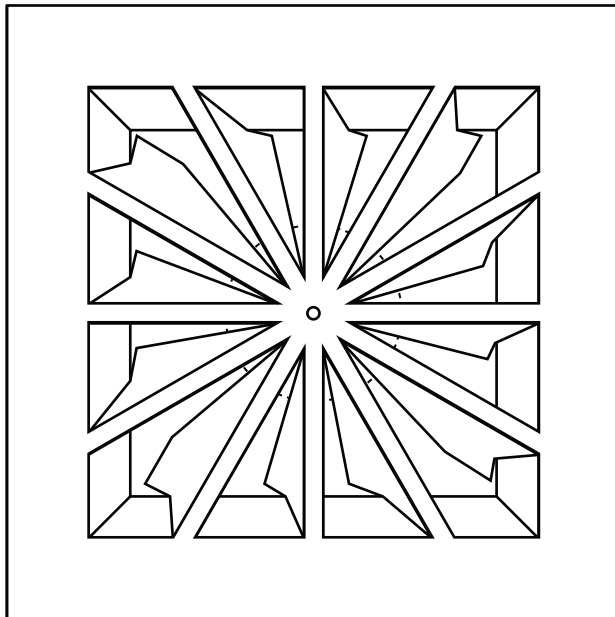
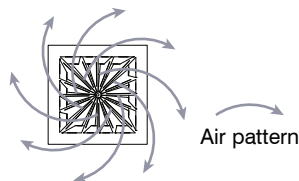
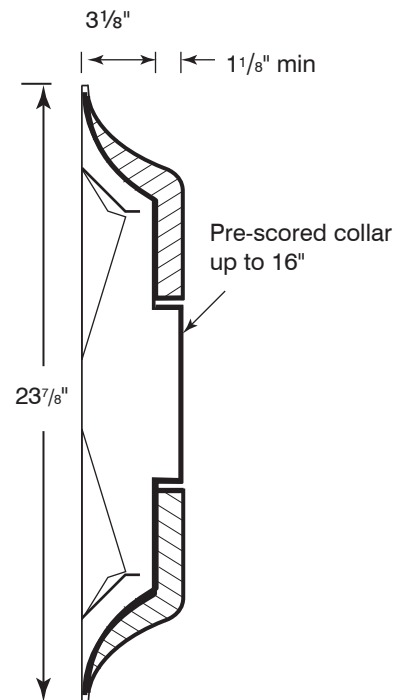
Finish: Stamped heavy gauge aluminum.
Material: Powder paint coating - white.
Air Pattern: Fixed 360° spiral pattern.
Mounting: Lay-in T-bar ceiling.



SUBMITTAL SHEET



Fiberglass back complies with
 A.S.T.M. E84 flame and smoke test.
 Scored for collar sizes up to 14" D.


ADTWI


Finish	
<input type="checkbox"/> /W	<input type="checkbox"/> /C Custom (Please Specify)
White (Default)	



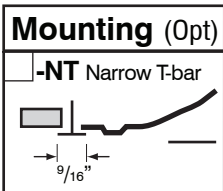
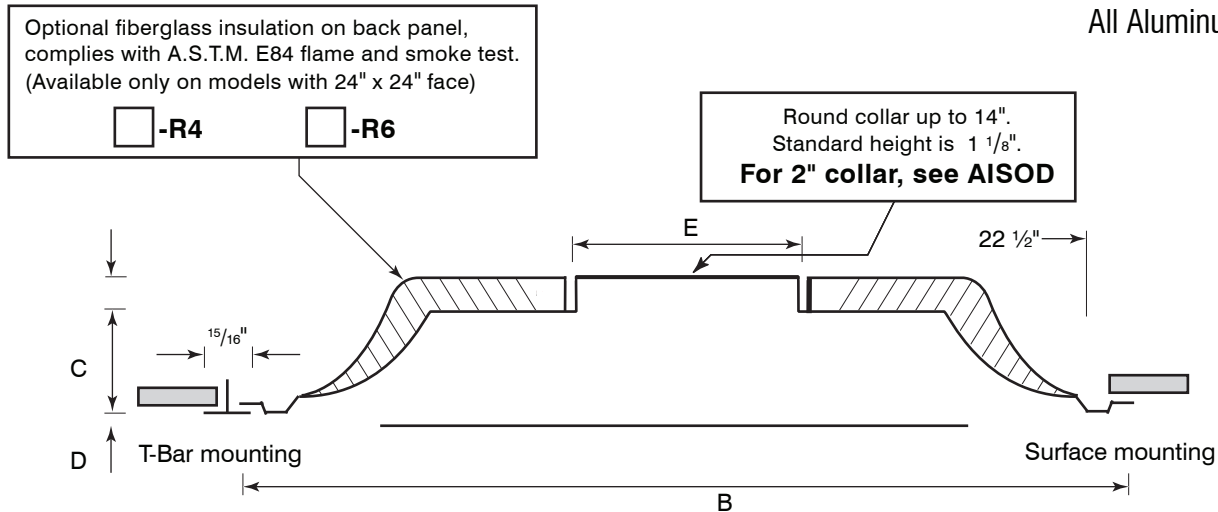
Schedule type: _____
 Job: _____
 Architect: _____
 Engineer: _____
 Contractor: _____

Square Plaque Diffuser - Architectural Line

- Material:** Stamped heavy gauge aluminium.
- Finish:** Powder paint coating - white.
- Mounting:** Surface or Lay-in T-bar ceiling.
- Air Pattern:** Fixed horizontal 360° diffusion.
- Safety:** Seismic tabs.
- Core Removal:** Unlock hanger brackets by swiveling lever down. Holding core panel at opposite sides, push upwards, then turn clockwise and drop core free from back plenum.



AISO
All Aluminum



Round Collar Baffles				
<input type="checkbox"/> W1 1way	<input type="checkbox"/> WC 2 Way Corner	<input type="checkbox"/> WO 2 Way Opposed	<input type="checkbox"/> W3 3 Way	<input type="checkbox"/> W4 4 Way (default)

Panel Option for T-bar lay-in Ceiling

<p>No fastening options available</p>	<table style="width: 100%;"> <tr> <th style="text-align: left;">Steel (WxH)</th> <th style="text-align: left;">Aluminum (WxH)</th> </tr> <tr> <td><input type="checkbox"/> -X2412</td> <td><input type="checkbox"/> -Y2412</td> </tr> <tr> <td><input type="checkbox"/> -X2424</td> <td><input type="checkbox"/> -Y2424</td> </tr> <tr> <td><input type="checkbox"/> -X2448</td> <td><input type="checkbox"/> -Y2448</td> </tr> <tr> <td><input type="checkbox"/> -X4824</td> <td><input type="checkbox"/> -Y4824</td> </tr> <tr> <td><input type="checkbox"/> -X2020</td> <td><input type="checkbox"/> -Y2020</td> </tr> </table>	Steel (WxH)	Aluminum (WxH)	<input type="checkbox"/> -X2412	<input type="checkbox"/> -Y2412	<input type="checkbox"/> -X2424	<input type="checkbox"/> -Y2424	<input type="checkbox"/> -X2448	<input type="checkbox"/> -Y2448	<input type="checkbox"/> -X4824	<input type="checkbox"/> -Y4824	<input type="checkbox"/> -X2020	<input type="checkbox"/> -Y2020
Steel (WxH)	Aluminum (WxH)												
<input type="checkbox"/> -X2412	<input type="checkbox"/> -Y2412												
<input type="checkbox"/> -X2424	<input type="checkbox"/> -Y2424												
<input type="checkbox"/> -X2448	<input type="checkbox"/> -Y2448												
<input type="checkbox"/> -X4824	<input type="checkbox"/> -Y4824												
<input type="checkbox"/> -X2020	<input type="checkbox"/> -Y2020												

✓	Model #	Duct Size	E	Face Dim B x B	C	D
	AISO 1206	6	5 7/8"	11 3/4" x 11 3/4"	1 3/4"	7/16"
	AISO 1208	8	7 7/8"	11 3/4" x 11 3/4"	1 3/4"	7/16"
	AISO 2406	6	5 7/8"	23 3/4" x 23 3/4"	2 7/8"	7/8"
	AISO 2408	8	7 7/8"	23 3/4" x 23 3/4"	2 7/8"	7/8"
	AISO 2410	10	9 7/8"	23 3/4" x 23 3/4"	2 7/8"	7/8"
	AISO 2412	12	11 7/8"	23 3/4" x 23 3/4"	2 7/8"	7/8"
	AISO 2414	14	13 7/8"	23 3/4" x 23 3/4"	2 7/8"	7/8"

Finish

<input type="checkbox"/> /W White (Default)	<input type="checkbox"/> /C Custom (Please Specify)
---	---



Schedule type: _____

Job: _____

Architect: _____

Engineer: _____

Contractor: _____

Square Plaque Diffuser - Architectural Line

2" High Collar, Individual Packaging

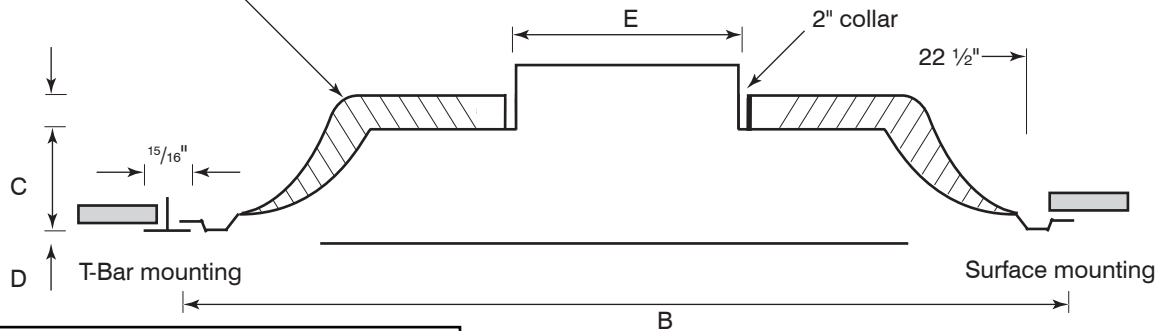
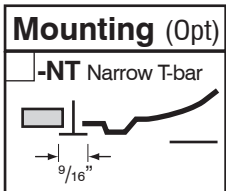
- Material:** Stamped heavy gauge aluminium.
- Finish:** Powder paint coating - white.
- Mounting:** Surface or Lay-in T-bar ceiling.
- Air Pattern:** Fixed horizontal 360° diffusion.
- Safety:** Seismic tabs.
- Core Removal:** Unlock hanger brackets by swiveling lever down. Holding core panel at opposite sides, push upwards, then turn clockwise and drop core free from back plenum.



AISOD
Aluminum

Optional fiberglass insulation on back panel, complies with A.S.T.M. E84 flame and smoke test. (Available only on models with 24" x 24" face)

-R4 -R6



Round Collar Baffles

<input type="checkbox"/> W1 1 Way	<input type="checkbox"/> WC 2 Way Corner	<input type="checkbox"/> WO 2 Way Opposed	<input type="checkbox"/> W3 3 Way	<input type="checkbox"/> W4 4 Way (default)

Panel Option for T-bar lay-in Ceiling

<p>No fastening options available</p>	Steel (WxH)	Aluminum (WxH)
	<input type="checkbox"/> -X2412	<input type="checkbox"/> -Y2412
	<input type="checkbox"/> -X2424	<input type="checkbox"/> -Y2424
	<input type="checkbox"/> -X2448	<input type="checkbox"/> -Y2448
	<input type="checkbox"/> -X4824	<input type="checkbox"/> -Y4824
	<input type="checkbox"/> -X2020	<input type="checkbox"/> -Y2020

✓	Model #	Duct Size	E	Face Dim B x B	C	D
	AISOD 1206	6	5 7/8"	11 3/4" x 11 3/4"	1 3/4"	7/16"
	AISOD 1208	8	7 7/8"	11 3/4" x 11 3/4"	1 3/4"	7/16"
	AISOD 2406	6	5 7/8"	23 3/4" x 23 3/4"	2 7/8"	7/8"
	AISOD 2408	8	7 7/8"	23 3/4" x 23 3/4"	2 7/8"	7/8"
	AISOD 2410	10	9 7/8"	23 3/4" x 23 3/4"	2 7/8"	7/8"
	AISOD 2412	12	11 7/8"	23 3/4" x 23 3/4"	2 7/8"	7/8"
	AISOD 2414	14	13 7/8"	23 3/4" x 23 3/4"	2 7/8"	7/8"

Finish

<input type="checkbox"/> /W White (Default)	<input type="checkbox"/> /C Custom (Please Specify)
---	---



<p>Equalizing Grid (Option)</p> <p>Refer to NEG</p>	<p>Damper (Option)</p> <p>Refer to N4 Refer to N5</p> <p>Opposed Blade Sliding Blade</p>		<p>Plaster Frame (Option)</p> <p>Refer to PF</p>
	<p>Refer to NEG</p>		

Schedule type: _____

Job: _____

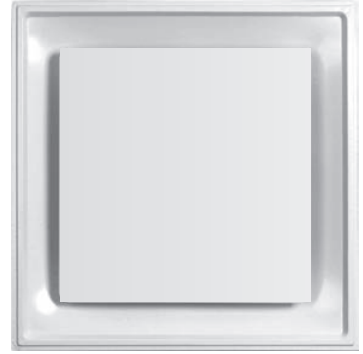
Architect: _____

Engineer: _____

Contractor: _____

Square Plaque Diffuser - Architectural Line Insulated, One Size Fits All


- Material:** Stamped heavy gauge aluminum.
- Finish:** Powder paint coating - white.
- Mounting:** Lay-in T-bar ceiling.
- Air Pattern:** Fixed horizontal 360° diffusion.
- Safety:** Seismic tabs.
- Core Removal:** Unlock hanger brackets by swiveling lever down. Holding core panel at opposite sides, push upwards, then turn clockwise and drop core free from back plenum.

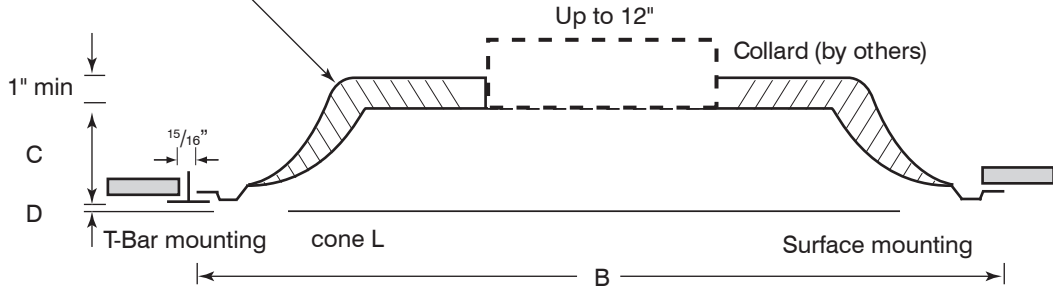


AISOI
Aluminum

-R6 fiberglass back complies with A.S.T.M. E84 flame and smoke test.

Scored for collar sizes up to 12" D. Contractor to install job-specific collar in field. For size 14", please refer to model DF3-R6 2414.





Model #	Face Dim B x B	C	D
AISOI	23 3/4" x 23 3/4"	2 7/8"	7/8"

Finish	
<input type="checkbox"/> /W White (Default)	<input type="checkbox"/> /C Custom (Please Specify) _____



Schedule type: _____

Job: _____

Architect: _____

Engineer: _____

Contractor: _____

For Special Shapes of ALB or ALS products

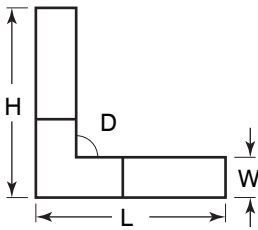
Important:

Attach with the regular ALB or ALS submittal drawing.
 All dimensions are "WIDTH INCLUDED".
 For ALB4 & ALB5 please indicate air flow direction with arrows on drawing.

Dimension Type

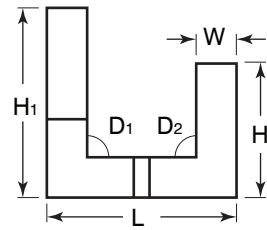
<input type="checkbox"/> -LS (default) List Size (1/4" more than neck size)	<input type="checkbox"/> -FS Face Size	<input type="checkbox"/> -NS Exact Neck Size
---	--	--

L-Shape



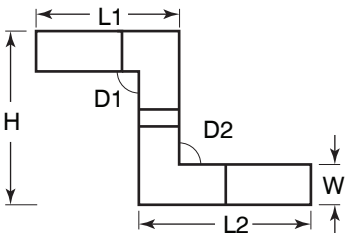
Dims	Qty	
H (in inches)	_____ "	_____ "
L (in inches)	_____ "	_____ "
W (in inches)	_____ "	_____ "
D (in degrees)	_____ °	_____ °

U-Shape



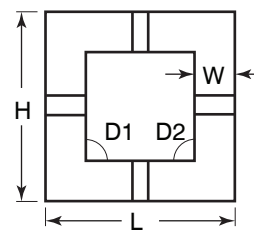
Dims	Qty	
H ₁ (in inches)	_____ "	_____ "
H ₂ (in inches)	_____ "	_____ "
L (in inches)	_____ "	_____ "
W (in inches)	_____ "	_____ "
D ₁ (in degrees)	_____ °	_____ °
D ₂ (in degrees)	_____ °	_____ °

Z-Shape



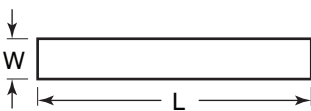
Dims	Qty	
L ₁ (in inches)	_____ "	_____ "
L ₂ (in inches)	_____ "	_____ "
H (in inches)	_____ "	_____ "
W (in inches)	_____ "	_____ "
D ₁ (in degrees)	_____ °	_____ °
D ₂ (in degrees)	_____ °	_____ °

O-Shape



Dims	Qty	
H (in inches)	_____ "	_____ "
L (in inches)	_____ "	_____ "
W (in inches)	_____ "	_____ "
D ₁ (in degrees)	_____ °	_____ °
D ₂ (in degrees)	_____ °	_____ °

I-Shape (Straight)



Dims	Qty	
L (in inches)	_____ "	_____ "
W (in inches)	_____ "	_____ "

Any Shape

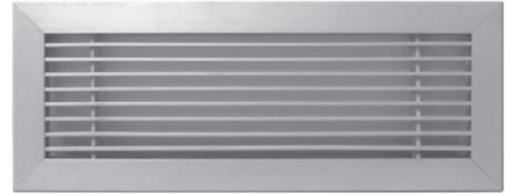
Dims	Qty	
_____	_____ "	_____ "
_____	_____ "	_____ "
_____	_____ "	_____ "
_____	_____ "	_____ "
_____	_____ °	_____ °
_____	_____ °	_____ °

Please submit sketch using dimensional examples above.

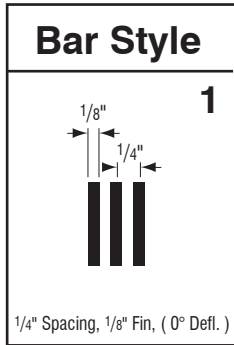
ALB Architectural Linear Bar Grille

Material: Extruded aluminum.
Lengths over 72 inches supplied as multiple sections.

Opposed Blade Damper (optional):
Galvanized steel construction.
Key-operated through grille face.

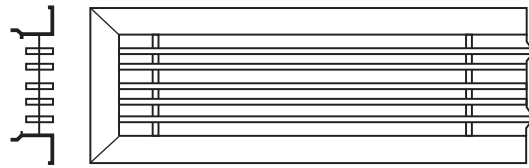


ALB10 / ALB17

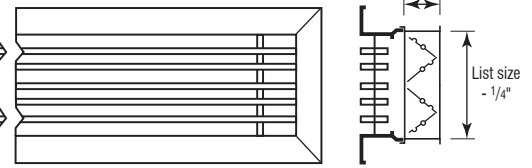


ALB10 = Grille Only

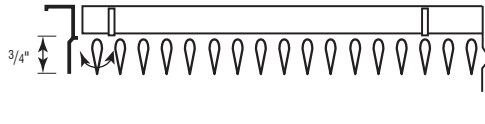
Braces set at max 11"
(with -RF max 6")



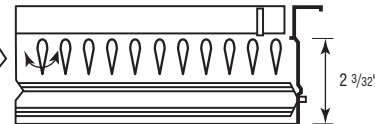
ALB17 = Grille + OBD
(Min Width 3")



ALB10-L = Grille + Air Equalizing Deflector
(Min Width 4")



ALB17-L = Grille + OBD + Air Equalizing Deflector
(Min Width 4")



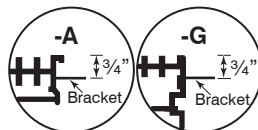
Margin Style			
<p>-A</p> <p>Listed + 9/32"</p> <p>9/16"</p> <p>1 9/32"</p> <p>Listed - 1/4"</p> <p>N/A with -3, -4, -5, -RM, -SB</p>	<p>-B</p> <p>Listed + 7/8"</p> <p>7/8"</p> <p>1 9/32"</p> <p>Listed - 1/4"</p> <p>N/A with -5, -SB, -RM</p>	<p>-E</p> <p>Listed + 1 1/4"</p> <p>1 1/16"</p> <p>1 9/32"</p> <p>Listed - 1/4"</p> <p>N/A with -5, -SB, -RM</p>	<p>-F</p> <p>Listed + 1 3/8"</p> <p>1"</p> <p>1 3/4"</p> <p>Listed - 1/4"</p> <p>ONLY with -1, -3, -5, -RM</p>
<p>-G</p> <p>Listed - 1/4"</p> <p>3/16"</p> <p>1 3/4"</p> <p>Listed - 1/4"</p> <p>ONLY with -1, -5, -RM, -SB</p>	<p>-R</p> <p>Listed + 1 1/4"</p> <p>1 1/16"</p> <p>1 9/32"</p> <p>Listed - 1/4"</p> <p>N/A with -5, -SB, -RM</p>	<p>-T</p> <p>Listed - 1/4"</p> <p>1 1/16"</p> <p>1 9/32"</p> <p>Listed - 1 3/4"</p> <p>N/A with -2, -3, -5, -SB, -RM</p>	<p>-P Plaster-In Frame</p> <p>Listed + 1 1/4"</p> <p>Plaster</p> <p>Gyproc</p> <p>Listed - 1/4"</p> <p>ONLY with -1, -5, -RM</p>

Fastening Method	
<p>-1 No Fastening</p> <p>N/A with -RM</p>	<p>-2 Spring clip</p> <p>N/A with -F, -G, -P, -T</p>
<p>-3 Screw</p> <p>N/A with -A, -G, -T</p>	<p>-4 Concealed</p> <p>N/A with -A, -F, -G, -P Min Width 4"</p>
<p>-5 Core spring clips</p> <p>Only with combined -RM and frames -F, -G, -P</p>	

Finish					
/W	/M	/A	/B	/L	/C Custom (Please Specify)
White (Default)	Mill Finish	Anodized	Brushed Aluminum N/A with -G, -R	Brushed & Lacquered N/A with -G, -R	



- Security Ceiling Wire -CW**
- Mounting Brackets for Sheetrock -SB**
(3/4" from the face) Only w/ -A -G
- Reinforced Floor Application -RF**
(6" max width for all frames, for over 6" use -F up to 20" more)
- Removable Core Application -RM**
(For ceiling add -5, -CW ; for wall add -5)
- Frame Gasket -GK**
- Vertical Bars -V**



Up to 1/8 inch increments without damper.
Dimensions shown contain expansion tolerances based on temperature rise of 40°F above the ambient temperature at which the material is fabricated.

Schedule type: _____

Job: _____

Architect: _____

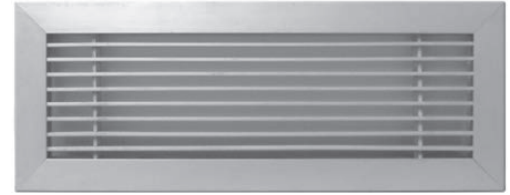
Engineer: _____

Contractor: _____

ALB Architectural Linear Bar Grille

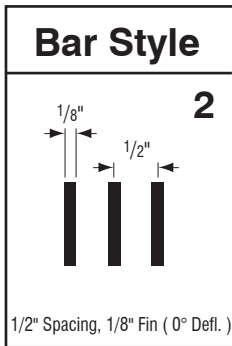
Material: Extruded aluminum.
Lengths over 72 inches supplied as multiple sections.

Opposed Blade Damper (optional):
Galvanized steel construction.
Key-operated through grille face.



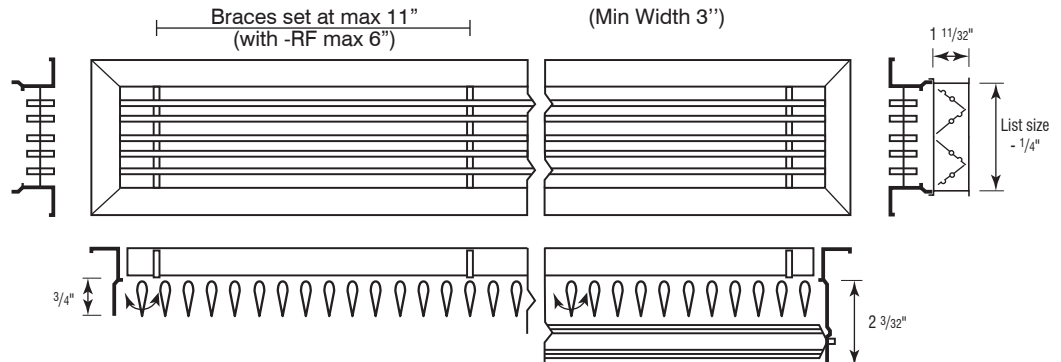
ALB20 / ALB27

SUBMITTAL SHEET



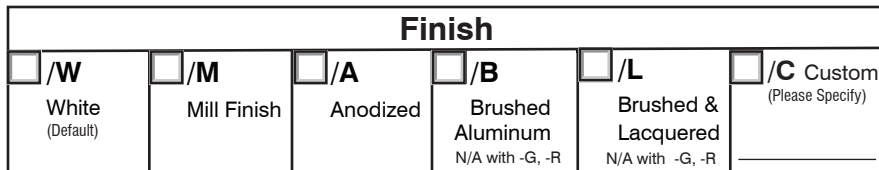
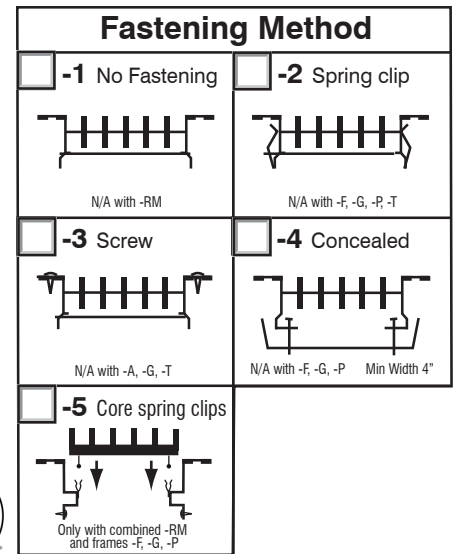
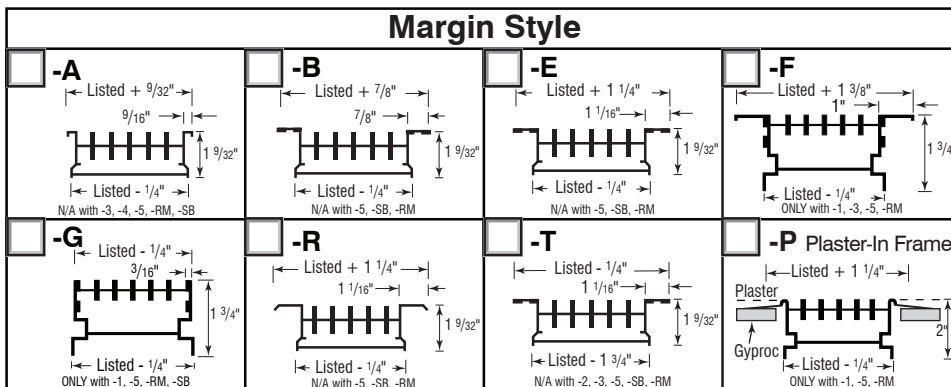
ALB20 = Grille Only

ALB27 = Grille + OBD
(Min Width 3")

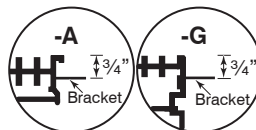


ALB20-L = Grille + Air Equalizing Deflector
(Min Width 4")

ALB27-L = Grille + OBD + Air Equalizing Deflector
(Min Width 4")



- Security Ceiling Wire -CW**
- Mounting Brackets for Sheetrock -SB**
(3/4" from the face) Only w/ -A -G
- Reinforced Floor Application -RF**
(6" max width for all frames, for over 6" use -F up to 20" more)
- Removable Core Application -RM**
(For ceiling add -5, -CW ; for wall add -5)
- Frame Gasket -GK**
- Vertical Bars -V**



Up to 1/8 inch increments without damper.
Dimensions shown contain expansion tolerances based on temperature rise of 40°F above the ambient temperature at which the material is fabricated.

Schedule type: _____

Job: _____

Architect: _____

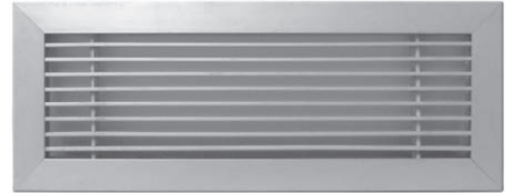
Engineer: _____

Contractor: _____

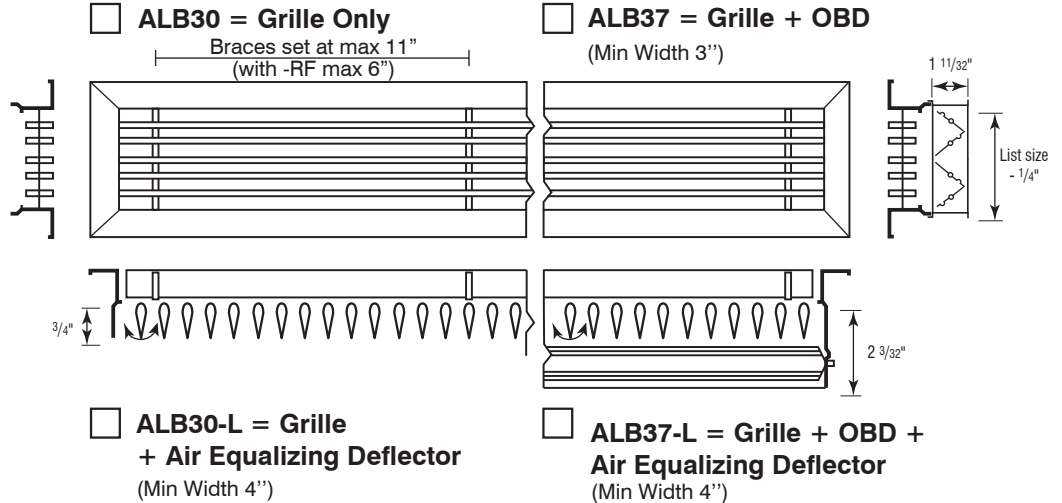
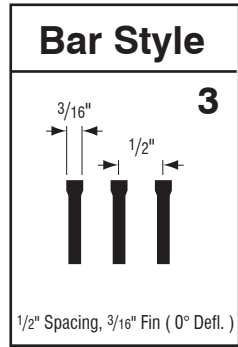
ALB Architectural Linear Bar Grille

Material: Extruded aluminum.
Lengths over 72 inches supplied as multiple sections.

Opposed Blade Damper (optional):
Galvanized steel construction.
Key-operated through grille face.



ALB30 / ALB37



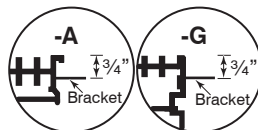
Margin Style			
<input type="checkbox"/> -A Listed + 9/32" 9/16" Listed - 1/4" N/A with -3, -4, -5, -RM, -SB	<input type="checkbox"/> -B Listed + 7/8" 7/8" Listed - 1/4" N/A with -5, -SB, -RM	<input type="checkbox"/> -E Listed + 1 1/4" 1 1/16" Listed - 1/4" N/A with -5, -SB, -RM	<input type="checkbox"/> -F Listed + 1 3/8" 1" Listed - 1/4" ONLY with -1, -3, -5, -RM
<input type="checkbox"/> -G Listed - 1/4" 3/16" Listed - 1/4" ONLY with -1, -5, -RM, -SB	<input type="checkbox"/> -R Listed + 1 1/4" 1 1/16" Listed - 1/4" N/A with -5, -SB, -RM	<input type="checkbox"/> -T Listed - 1/4" 1 1/16" Listed - 1 3/4" N/A with -2, -3, -5, -SB, -RM	<input type="checkbox"/> -P Plaster-In Frame Plaster Gyproc Listed + 1 1/4" Listed - 1/4" ONLY with -1, -5, -RM

Fastening Method	
<input type="checkbox"/> -1 No Fastening N/A with -RM	<input type="checkbox"/> -2 Spring clip N/A with -F, -G, -P, -T
<input type="checkbox"/> -3 Screw N/A with -A, -G, -T	<input type="checkbox"/> -4 Concealed N/A with -F, -G, -P Min Width 4"
<input type="checkbox"/> -5 Core spring clips Only with combined -RM and frames -F, -G, -P	

Finish					
<input type="checkbox"/> /W White (Default)	<input type="checkbox"/> /M Mill Finish	<input type="checkbox"/> /A Anodized	<input type="checkbox"/> /B Brushed Aluminum N/A with -G, -R	<input type="checkbox"/> /L Brushed & Lacquered N/A with -G, -R	<input type="checkbox"/> /C Custom (Please Specify)



- Security Ceiling Wire -CW**
- Mounting Brackets for Sheetrock -SB**
(3/4" from the face) Only w/ -A -G
- Reinforced Floor Application -RF**
(6" max width for all frames, for over 6" use -F up to 20" more)
- Removable Core Application -RM**
(For ceiling add -5, -CW ; for wall add -5)
- Frame Gasket -GK**
- Vertical Bars -V**



Up to 1/8 inch increments without damper.
Dimensions shown contain expansion tolerances based on temperature rise of 40°F above the ambient temperature at which the material is fabricated.

Schedule type: _____

Job: _____

Architect: _____

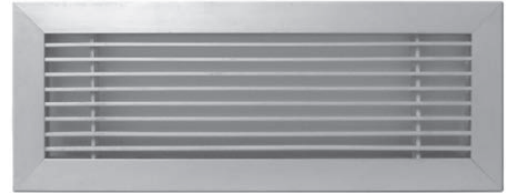
Engineer: _____

Contractor: _____

ALB Architectural Linear Bar Grille

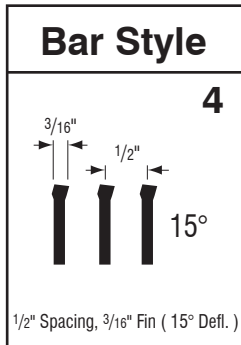
Material: Extruded aluminum.
Lengths over 72 inches supplied as multiple sections.

Opposed Blade Damper (optional):
Galvanized steel construction.
Key-operated through grille face.



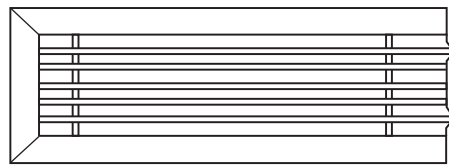
ALB40 / ALB47

SUBMITTAL SHEET



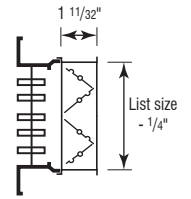
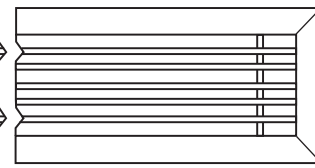
ALB40 = Grille Only

Braces set at max 11"
(with -RF max 6")

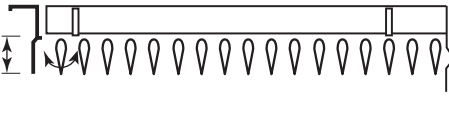


ALB47 = Grille + OBD

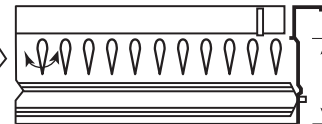
(Min Width 3")



ALB40-L = Grille + Air Equalizing Deflector
(Min Width 4")



ALB47-L = Grille + OBD + Air Equalizing Deflector
(Min Width 4")



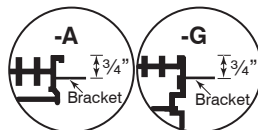
Margin Style			
<p>-A</p> <p>Listed + 9/32"</p> <p>9/16" →</p> <p>1 9/32"</p> <p>← Listed - 1/4" →</p> <p>N/A with -3, -4, -5, -RM, -SB</p>	<p>-B</p> <p>Listed + 7/8"</p> <p>7/8" →</p> <p>1 9/32"</p> <p>← Listed - 1/4" →</p> <p>N/A with -5, -SB, -RM</p>	<p>-E</p> <p>Listed + 1 1/4"</p> <p>1 1/16" →</p> <p>1 9/32"</p> <p>← Listed - 1/4" →</p> <p>N/A with -5, -SB, -RM</p>	<p>-F</p> <p>Listed + 1 3/8"</p> <p>1" →</p> <p>1 3/4"</p> <p>← Listed - 1/4" →</p> <p>ONLY with -1, -3, -5, -RM</p>
<p>-G</p> <p>Listed - 1/4"</p> <p>3/16" →</p> <p>1 3/4"</p> <p>← Listed - 1/4" →</p> <p>ONLY with -1, -5, -RM, -SB</p>	<p>-R</p> <p>Listed + 1 1/4"</p> <p>1 1/16" →</p> <p>1 9/32"</p> <p>← Listed - 1/4" →</p> <p>N/A with -5, -SB, -RM</p>	<p>-T</p> <p>Listed - 1/4"</p> <p>1 1/16" →</p> <p>1 9/32"</p> <p>← Listed - 1 3/4" →</p> <p>N/A with -2, -3, -5, -SB, -RM</p>	<p>-P Plaster-In Frame</p> <p>Listed + 1 1/4"</p> <p>Plaster</p> <p>Gyproc</p> <p>← Listed - 1/4" →</p> <p>ONLY with -1, -5, -RM</p>

Fastening Method	
<p>-1 No Fastening</p> <p>N/A with -RM</p>	<p>-2 Spring clip</p> <p>N/A with -F, -G, -P, -T</p>
<p>-3 Screw</p> <p>N/A with -A, -G, -T</p>	<p>-4 Concealed</p> <p>N/A with -F, -G, -P</p> <p>Min Width 4"</p>
<p>-5 Core spring clips</p> <p>Only with combined -RM and frames -F, -G, -P</p>	

Finish					
<p>/W</p> <p>White (Default)</p>	<p>/M</p> <p>Mill Finish</p>	<p>/A</p> <p>Anodized</p>	<p>/B</p> <p>Brushed Aluminum N/A with -G, -R</p>	<p>/L</p> <p>Brushed & Lacquered N/A with -G, -R</p>	<p>/C Custom (Please Specify)</p>



- Security Ceiling Wire -CW**
- Mounting Brackets for Sheetrock -SB**
(3/4" from the face) Only w/ -A -G
- Reinforced Floor Application -RF**
(6" max width for all frames, for over 6" use -F up to 20" more)
- Removable Core Application -RM**
(For ceiling add -5, -CW ; for wall add -5)
- Frame Gasket -GK**
- Vertical Bars -V**



Up to 1/8 inch increments without damper.
Dimensions shown contain expansion tolerances based on temperature rise of 40°F above the ambient temperature at which the material is fabricated.

Schedule type: _____

Job: _____

Architect: _____

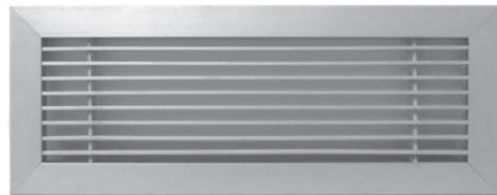
Engineer: _____

Contractor: _____

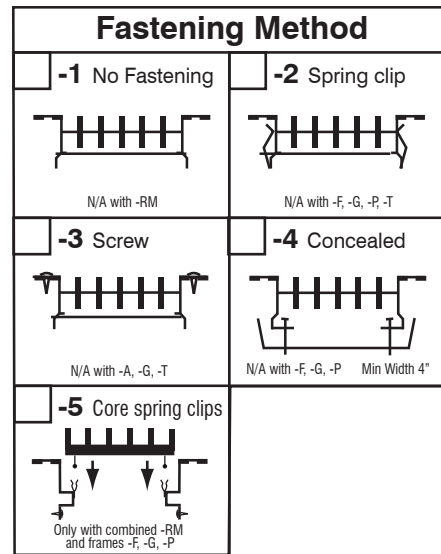
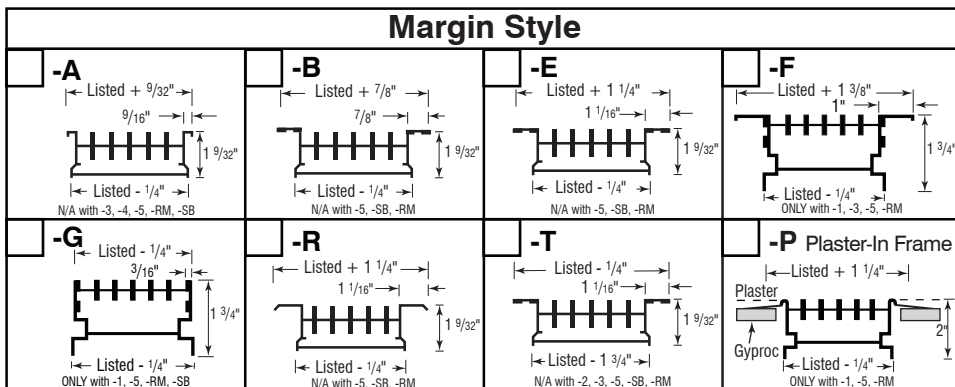
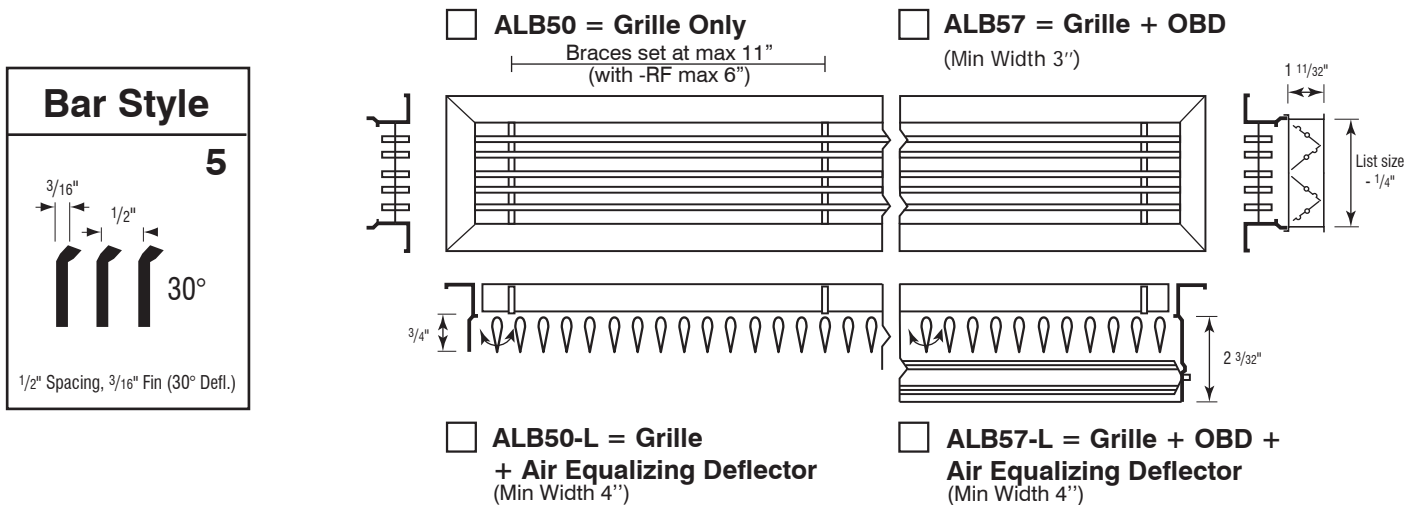
ALB Architectural Linear Bar Grille

Material: Extruded aluminum.
Lengths over 72 inches supplied as multiple sections.

Opposed Blade Damper (optional):
Galvanized steel construction.
Key-operated through grille face.



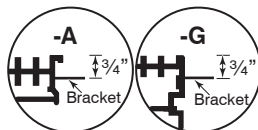
ALB50 / ALB57



Finish					
<input type="checkbox"/> /W White (Default)	<input type="checkbox"/> /M Mill Finish	<input type="checkbox"/> /A Anodized	<input type="checkbox"/> /B Brushed Aluminum N/A with -G, -R	<input type="checkbox"/> /L Brushed & Lacquered N/A with -G, -R	<input type="checkbox"/> /C Custom (Please Specify)



- Security Ceiling Wire -CW**
- Mounting Brackets for Sheetrock -SB**
(3/4" from the face) Only w/ -A -G
- Reinforced Floor Application -RF**
(6" max width for all frames, for over 6" use -F up to 20" more)
- Removable Core Application -RM**
(For ceiling add -5, -CW ; for wall add -5)
- Frame Gasket -GK**
- Vertical Bars -V**



Up to 1/8 inch increments without damper.
Dimensions shown contain expansion tolerances based on temperature rise of 40°F above the ambient temperature at which the material is fabricated.

Schedule type: _____

Job: _____

Architect: _____

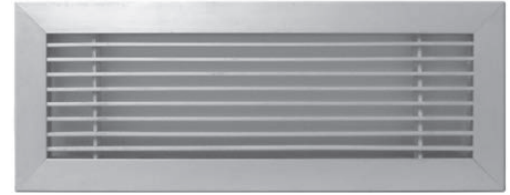
Engineer: _____

Contractor: _____

ALB Architectural Linear Bar Grille

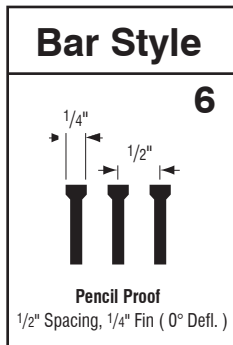
Material: Extruded aluminum.
Lengths over 72 inches supplied as multiple sections.

Opposed Blade Damper (optional):
Galvanized steel construction.
Key-operated through grille face.



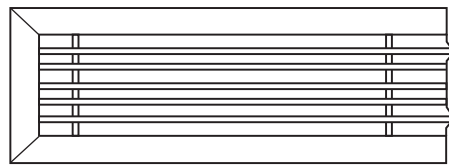
ALB60 / ALB67

SUBMITTAL SHEET



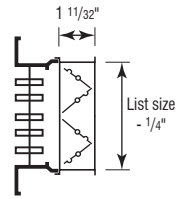
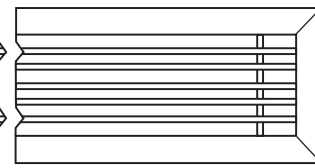
ALB60 = Grille Only

Braces set at max 11"
(with -RF max 6")

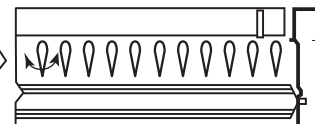
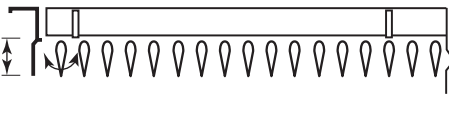


ALB67 = Grille + OBD

(Min Width 3")



ALB60-L = Grille + Air Equalizing Deflector
(Min Width 4")



ALB67-L = Grille + OBD + Air Equalizing Deflector
(Min Width 4")

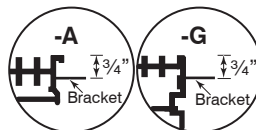
Margin Style			
<p>-A</p> <p>Listed + 9/32"</p> <p>9/16"</p> <p>1 9/32"</p> <p>Listed - 1/4"</p> <p>N/A with -3, -4, -5, -RM, -SB</p>	<p>-B</p> <p>Listed + 7/8"</p> <p>7/8"</p> <p>1 9/32"</p> <p>Listed - 1/4"</p> <p>N/A with -5, -SB, -RM</p>	<p>-E</p> <p>Listed + 1 1/4"</p> <p>1 1/16"</p> <p>1 9/32"</p> <p>Listed - 1/4"</p> <p>N/A with -5, -SB, -RM</p>	<p>-F</p> <p>Listed + 1 3/8"</p> <p>1"</p> <p>1 3/4"</p> <p>Listed - 1/4"</p> <p>ONLY with -1, -3, -5, -RM</p>
<p>-G</p> <p>Listed - 1/4"</p> <p>3/16"</p> <p>1 3/4"</p> <p>Listed - 1/4"</p> <p>ONLY with -1, -5, -RM, -SB</p>	<p>-R</p> <p>Listed + 1 1/4"</p> <p>1 1/16"</p> <p>1 9/32"</p> <p>Listed - 1/4"</p> <p>N/A with -5, -SB, -RM</p>	<p>-T</p> <p>Listed - 1/4"</p> <p>1 1/16"</p> <p>1 9/32"</p> <p>Listed - 1 3/4"</p> <p>N/A with -2, -3, -5, -SB, -RM</p>	<p>-P Plaster-In Frame</p> <p>Listed + 1 1/4"</p> <p>Plaster</p> <p>Gyproc</p> <p>Listed - 1/4"</p> <p>ONLY with -1, -5, -RM</p>

Fastening Method	
<p>-1 No Fastening</p> <p>N/A with -RM</p>	<p>-2 Spring clip</p> <p>N/A with -F, -G, -P, -T</p>
<p>-3 Screw</p> <p>N/A with -A, -G, -T</p>	<p>-4 Concealed</p> <p>N/A with -F, -G, -P Min Width 4"</p>
<p>-5 Core spring clips</p> <p>Only with combined -RM and frames -F, -G, -P</p>	

Finish					
/W	/M	/A	/B	/L	/C Custom (Please Specify)
White (Default)	Mill Finish	Anodized	Brushed Aluminum N/A with -G, -R	Brushed & Lacquered N/A with -G, -R	



- Security Ceiling Wire -CW**
- Mounting Brackets for Sheetrock -SB**
(3/4" from the face) Only w/ -A -G
- Reinforced Floor Application -RF**
(6" max width for all frames, for over 6" use -F up to 20" more)
- Removable Core Application -RM**
(For ceiling add -5, -CW ; for wall add -5)
- Frame Gasket -GK**
- Vertical Bars -V**



Up to 1/8 inch increments without damper.
Dimensions shown contain expansion tolerances based on temperature rise of 40°F above the ambient temperature at which the material is fabricated.

Schedule type: _____

Job: _____

Architect: _____

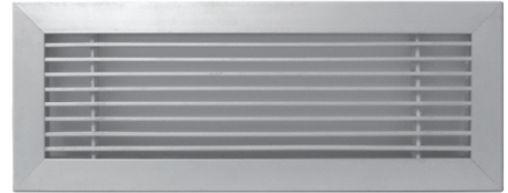
Engineer: _____

Contractor: _____

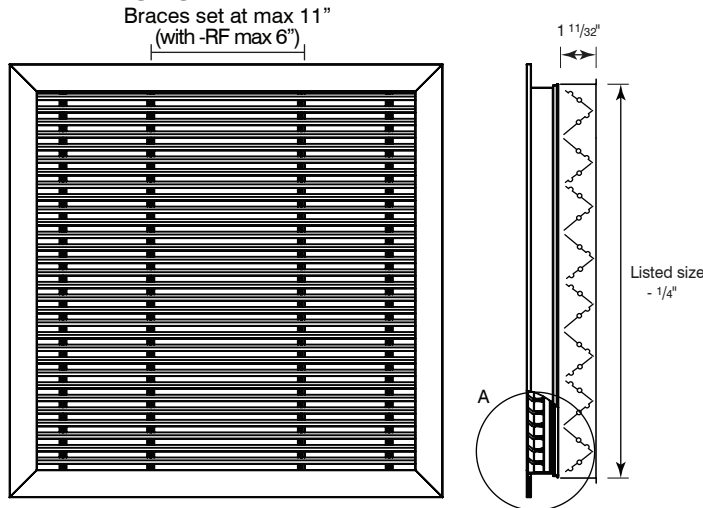
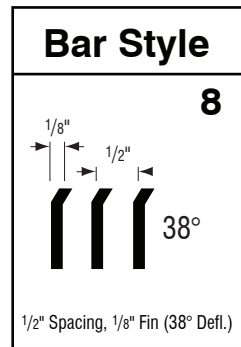
ALB Architectural Linear Bar Grille

Material: Extruded aluminum.
Lengths over 72 inches supplied as multiple sections.

Opposed Blade Damper (optional):
Galvanized steel construction.
Key-operated through grille face.



ALB80 / ALB87



- ALB80 = Grille Only**
- ALB87 = Grille + OBD**
(Min Width 3")
- ALB80-L = Grille + Air Equalizing Deflector**
(Min Width 4")
- ALB87-L = Grille + OBD + Air Equalizing Deflector**
(Min Width 4")

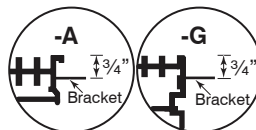
Margin Style			
<p>-A</p> <p>N/A with -3, -4, -5, -RM, -SB</p>	<p>-B</p> <p>N/A with -5, -SB, -RM</p>	<p>-E</p> <p>N/A with -5, -SB, -RM</p>	<p>-F</p> <p>ONLY with -1, -3, -5, -RM</p>
<p>-G</p> <p>ONLY with -1, -5, -RM, -SB</p>	<p>-R</p> <p>N/A with -5, -SB, -RM</p>	<p>-T</p> <p>N/A with -2, -3, -5, -SB, -RM</p>	<p>-P Plaster-In Frame</p> <p>ONLY with -1, -5, -RM</p>

Fastening Method	
<p>-1 No Fastening</p> <p>N/A with -RM</p>	<p>-2 Spring clip</p> <p>N/A with -F, -G, -P, -T</p>
<p>-3 Screw</p> <p>N/A with -A, -G, -T</p>	<p>-4 Concealed</p> <p>N/A with -F, -G, -P Min Width 4"</p>
<p>-5 Core spring clips</p> <p>Only with combined -RM and frames -F, -G, -P</p>	

Finish					
<p>/W</p> <p>White (Default)</p>	<p>/M</p> <p>Mill Finish</p>	<p>/A</p> <p>Anodized</p>	<p>/B</p> <p>Brushed Aluminum N/A with -G, -R</p>	<p>/L</p> <p>Brushed & Lacquered N/A with -G, -R</p>	<p>/C Custom (Please Specify)</p>



- Security Ceiling Wire -CW**
- Mounting Brackets for Sheetrock -SB**
(3/4" from the face) Only w/ -A -G
- Reinforced Floor Application -RF**
(6" max width for all frames, for over 6" use -F up to 20" more)
- Removable Core Application -RM**
(For ceiling add -5, -CW ; for wall add -5)
- Frame Gasket -GK**
- Vertical Bars -V**



Up to 1/8 inch increments without damper.
Dimensions shown contain expansion tolerances based on temperature rise of 40°F above the ambient temperature at which the material is fabricated.

Schedule type: _____

Job: _____

Architect: _____

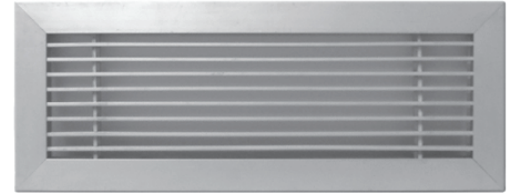
Engineer: _____

Contractor: _____

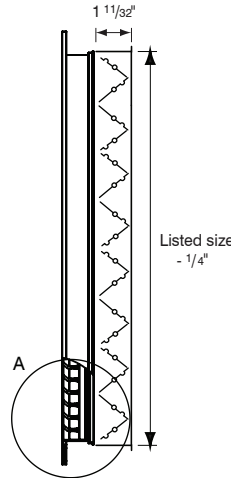
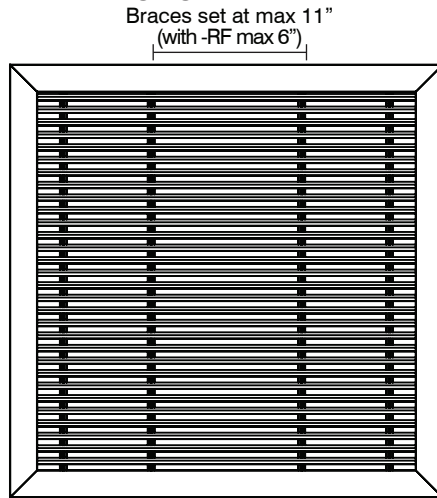
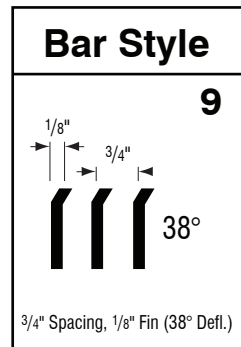
ALB Architectural Linear Bar Grille

Material: Extruded aluminum.
Lengths over 72 inches supplied as multiple sections.

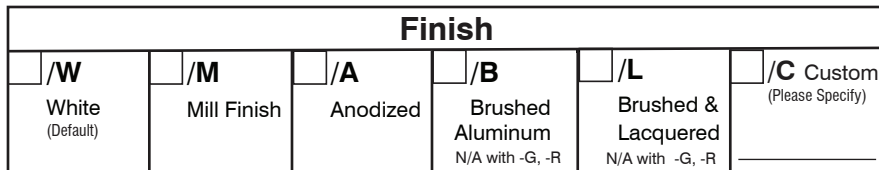
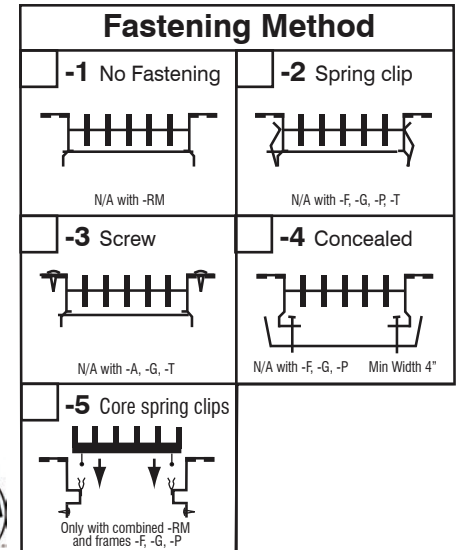
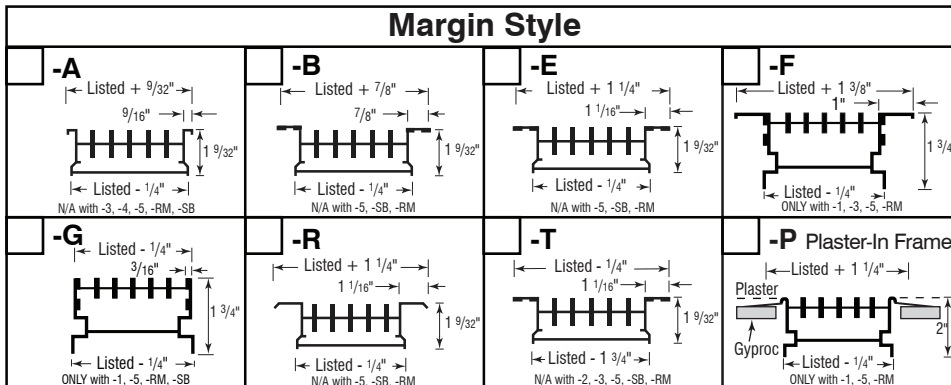
Opposed Blade Damper (optional):
Galvanized steel construction.
Key-operated through grille face.


ALB90 / ALB97

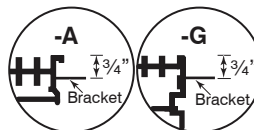
SUBMITTAL SHEET



- ALB90 = Grille Only**
- ALB97 = Grille + OBD**
(Min Width 3")
- ALB90-L = Grille + Air Equalizing Deflector**
(Min Width 4")
- ALB97-L = Grille + OBD + Air Equalizing Deflector**
(Min Width 4")



- Security Ceiling Wire -CW**
- Mounting Brackets for Sheetrock -SB**
(3/4" from the face) Only w/ -A -G
- Reinforced Floor Application -RF**
(6" max width for all frames, for over 6" use -F up to 20" more)
- Removable Core Application -RM**
(For ceiling add -5, -CW ; for wall add -5)
- Frame Gasket -GK**
- Vertical Bars -V**



Up to 1/8 inch increments without damper.
Dimensions shown contain expansion tolerances based on temperature rise of 40°F above the ambient temperature at which the material is fabricated.

Schedule type: _____

Job: _____

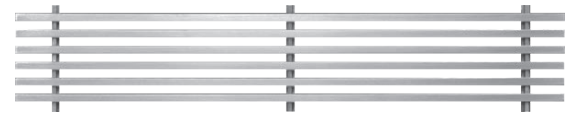
Architect: _____

Engineer: _____

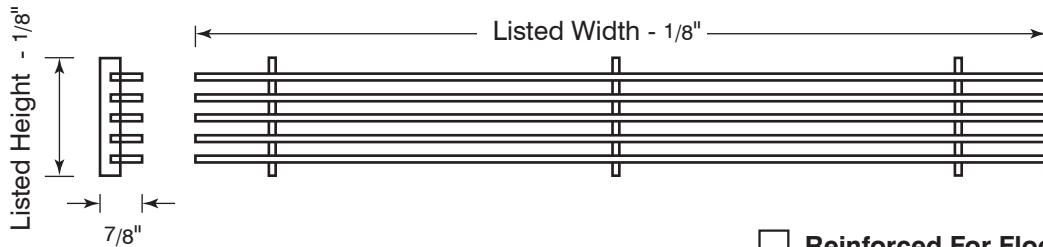
Contractor: _____

Linear Bar Grille - Core Only

Material: Extruded aluminum.
Lengths over 72 inches supplied as multiple sections.



ALBCO6



Reinforced For Floor Application -RF
(Up to 6" wide)

Mounting	
<input type="checkbox"/> -P	Plaster-In Frame

Bar Style							
ALBCO1 Narrow	ALBCO2 	ALBCO3 	ALBCO4 	ALBCO5 	ALBCO6 Pencil Proof	ALBCO8 	ALBCO9



Finish					
<input type="checkbox"/> /M Mill Finish	<input type="checkbox"/> /W White (Default)	<input type="checkbox"/> /A Anodized	<input type="checkbox"/> /B Brushed	<input type="checkbox"/> /L Brushed & Lacquered	<input type="checkbox"/> /C Custom (please specify)

Schedule type: _____

Job: _____

Architect: _____

Engineer: _____

Contractor: _____

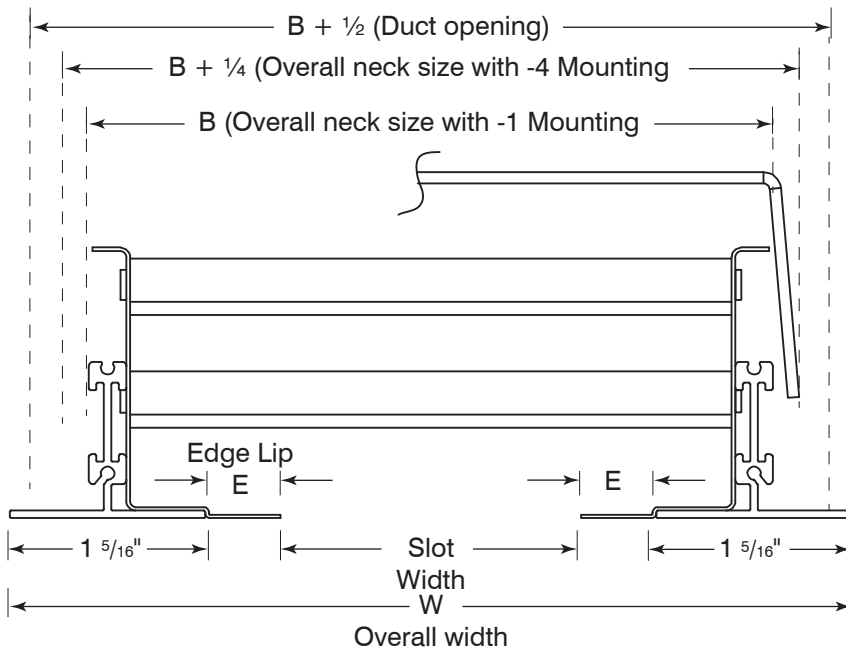
Dimensions shown contain expansion tolerances based on temperature rise of 40°F above the ambient temperature at which the material is fabricated.

Linear Flow Bar Diffuser - 1 Slot

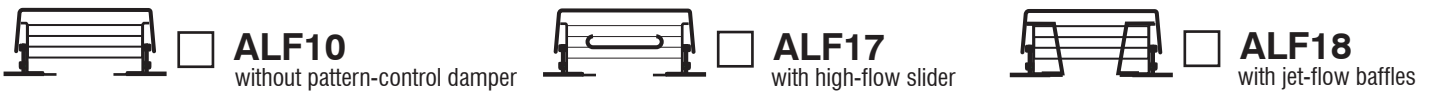
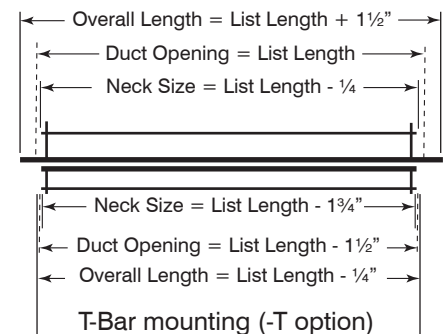
Material: Extruded aluminum construction.
Mounting: Surface or Lay-in T-bar ceiling.
 Plaster-in Frame (Tape & Spackle)



ALF10 / ALF17 / ALF18
 (ALF10 shown here)



Surface mounting (-E and -P options)



Mounting		
<input type="checkbox"/> -P Plaster-In Frame	<input type="checkbox"/> -E Surface Mounting	<input type="checkbox"/> -T T-Bar mounting

Fastening Method			
<input type="checkbox"/> -1 No Fastening	<input type="checkbox"/> -3 Mounting Hole	<input type="checkbox"/> -4 Concealed	<input type="checkbox"/> -6 Adhesive tape tape

✓	Slot Width	B	W	C	E
	1	2 9/16"	3 5/8"	1 1/2"	0"
	1.5	3 9/16"	4 5/8"	1 1/2"	1/4"
	2	4 9/16"	5 5/8"	1 3/4"	1/2"
	2.5	5 9/16"	6 5/8"	1 3/4"	3/4"
	3	6 9/16"	7 5/8"	1 3/4"	1"

Option LS	
Optional Return Hood/Light Shield Model	
<input type="checkbox"/> -LS	

Finish	
<input type="checkbox"/> /W White (Default)	<input type="checkbox"/> /C Custom (Please Specify)



Schedule type: _____
 Job: _____
 Architect: _____
 Engineer: _____
 Contractor: _____

SUBMITTAL SHEET

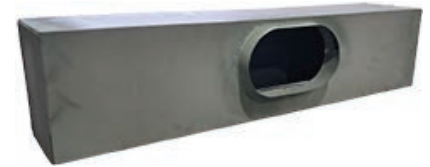
ALF1APL / ALF1APLH / ALF1APLIN
ALF1APLHIN Series

All dimensions are in inches

SUBMITTAL SHEET

Plenums for ALF Flow Bar Diffusers and Returns with 1 Slot

Material: 20 gauge Aluminum.

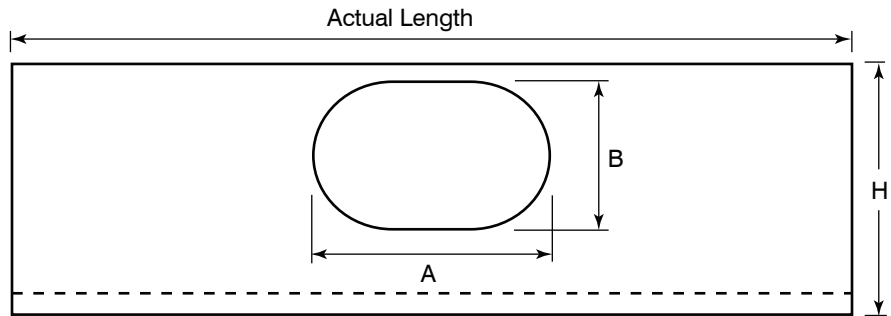
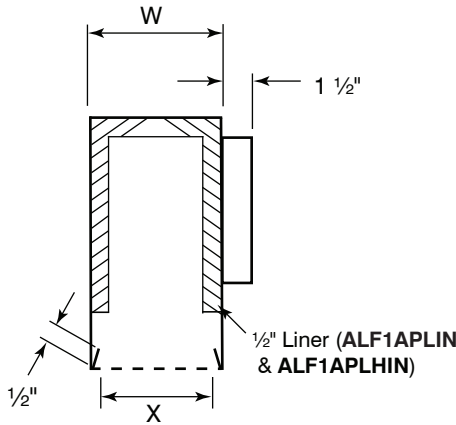


ALF1APL
H = 8". Standard Plenum.

ALF1APLIN - 1/2" Liner Insulation
H = 8". Standard Plenum. - 1/2" Liner Insulation.

ALF1APLH
H = 11". High Plenum.

ALF1APLHIN - 1/2" Liner Insulation
H = 11". High Plenum. - 1/2" Liner Insulation.



✓		Inlet Size	With H=8"		With H=11"	
			A	B	A	B
	-04	4"	4"	4"	-	-
	-05	5"	5"	5"	-	-
	-06	6"	6 1/4"	5 1/4"	6"	6"
	-08	8"	9 3/8"	5 1/4"	9 3/8"	5 1/4"
	-08*	8"	-	-	8"	8"
	-10	10"	12 1/2"	5 1/4"	11"	8"
	-12**	12"	-	-	14 1/8"	8"
	-14**	14"	-	-	17 1/4"	8"

✓	Slots Width	W	X
	1"	3 3/8"	2 15/16"
	1 1/2"	4 3/8"	3 15/16"
	2"	5 3/8"	4 15/16"
	2 1/2"	6 3/8"	5 15/16"
	3"	7 3/8"	6 15/16"

*8" round neck available only with 11" high plenums

**12" & 14" oval neck available only with 11" high plenums

ALF10/ALF17/ALF18 Mounting

<input type="checkbox"/> -E Surface	Actual Length = Nominal Length
<input type="checkbox"/> -T T-bar Lay-in	Actual Length = Nominal Length - 1/4"
<input type="checkbox"/> -P Plaster-in	Actual Length = Nominal Length

Schedule type: _____

Job: _____

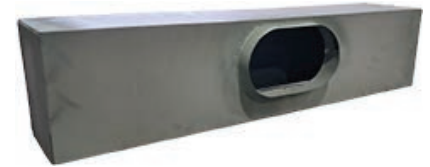
Architect: _____

Engineer: _____

Contractor: _____

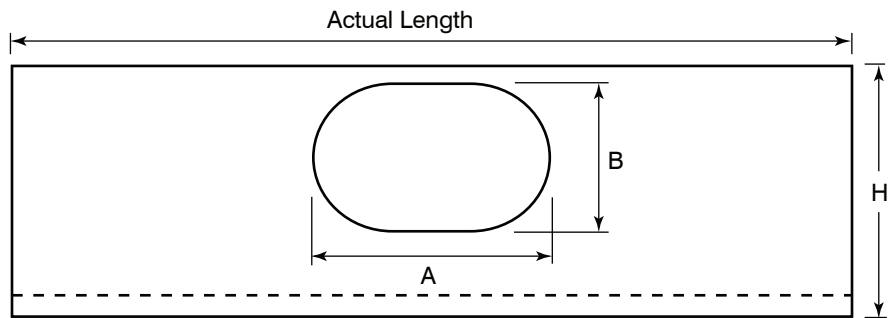
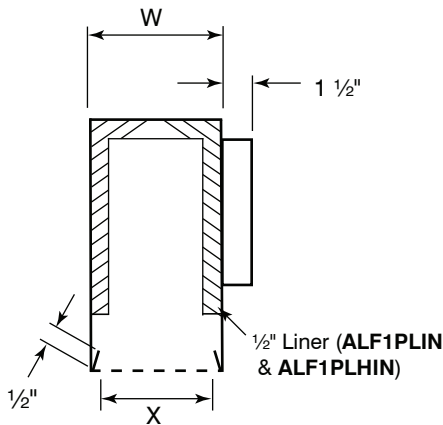
Plenums for ALF Flow Bar Diffusers and Returns with 1 Slot

Material: 24 gauge galvanized



SUBMITTAL SHEET

- | | |
|--|---|
| <input type="checkbox"/> ALF1PL
H = 8". Standard Plenum. | <input type="checkbox"/> ALF1PLIN
H = 8". Standard Plenum. - 1/2" Liner Insulation. |
| <input type="checkbox"/> ALF1PLH
H = 11". High Plenum. | <input type="checkbox"/> ALF1PLHIN
H = 11". High Plenum. - 1/2" Liner Insulation. |



✓	Inlet Size	With H=8"		With H=11"	
		A	B	A	B
	-04	4"	4"	-	-
	-05	5"	5"	-	-
	-06	6 1/4"	5 1/4"	6"	6"
	-08	9 3/8"	5 1/4"	9 3/8"	5 1/4"
	-08*	-	-	8"	8"
	-10	12 1/2"	5 1/4"	11"	8"
	-12**	-	-	14 1/8"	8"
	-14**	-	-	17 1/4"	8"

✓	Slots Width	W	X
	1"	3 3/8"	2 15/16"
	1 1/2"	4 3/8"	3 15/16"
	2"	5 3/8"	4 15/16"
	2 1/2"	6 3/8"	5 15/16"
	3"	7 3/8"	6 15/16"

*8" round neck available only with 11" high plenums

**12" & 14" oval neck available only with 11" high plenums

ALF10/ALF17/ALF18 Mounting

<input type="checkbox"/> -E Surface	Actual Length = Nominal Length
<input type="checkbox"/> -T T-bar Lay-in	Actual Length = Nominal Length - 1/4"
<input type="checkbox"/> -P Plaster-in	Actual Length = Nominal Length

Schedule type: _____

Job: _____

Architect: _____

Engineer: _____

Contractor: _____

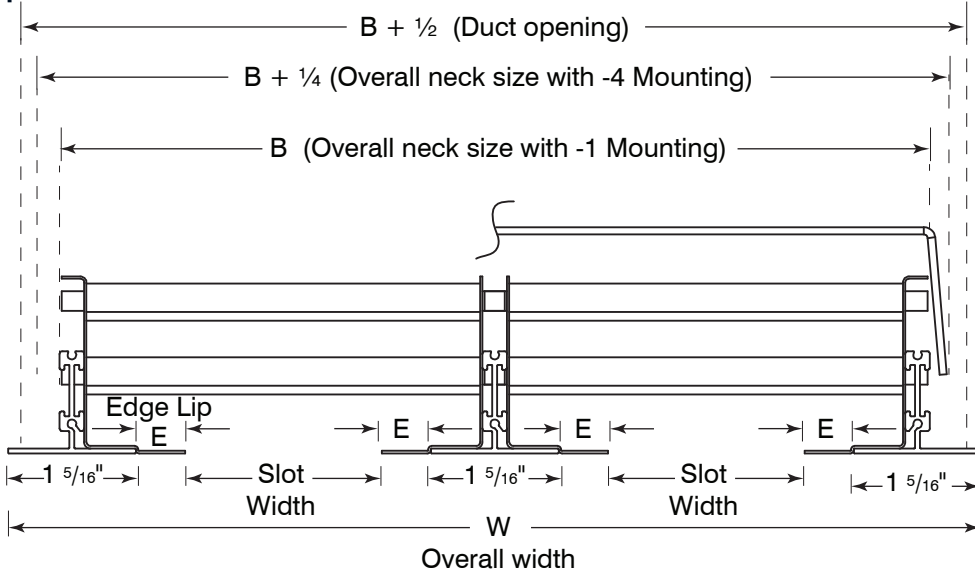
SUBMITTAL SHEET

Linear Flow Bar Diffuser - 2 Slot

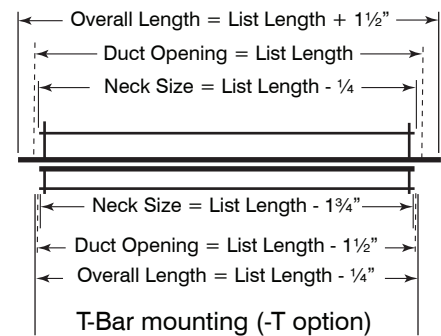
Material: Extruded aluminum construction
Mounting: Surface or Lay-in T-bar ceiling.
 Plaster-in Frame (Tape & Spackle)



ALF20 / ALF27 / ALF28 (ALF27 shown here)



Surface mounting (-E and -P options)



ALF20
without pattern-control damper



ALF27
with high-flow slider



ALF28
with jet-flow baffles

Mounting		
<input type="checkbox"/> -P Plaster-In Frame	<input type="checkbox"/> -E Surface Mounting	<input type="checkbox"/> -T T-Bar mounting

Fastening Method		
<input type="checkbox"/> -1 No Fastening	<input type="checkbox"/> -3 Mounting Hole	<input type="checkbox"/> -4 Concealed

Option LS
Optional Return Hood/Light Shield Model

-LS

Finish	
<input type="checkbox"/> /W White (Default)	<input type="checkbox"/> /C Custom (Please Specify)



✓	Slot Width	B	W	C	E
	1"	4 7/8"	5 15/16"	1 1/2"	0"
	1 1/2"	6 7/8"	7 15/16"	1 1/2"	1/4"
	2"	8 7/8"	9 15/16"	1 3/4"	1/2"
	2 1/2"	10 7/8"	11 15/16"	1 3/4"	3/4"
	3"	12 7/8"	13 15/16"	1 3/4"	1"

Schedule type: _____

Job: _____

Architect: _____

Engineer: _____

Contractor: _____

Plenums for ALF Flow Bar Diffusers and Returns with 2 Slots

Material: 20 gauge Aluminum

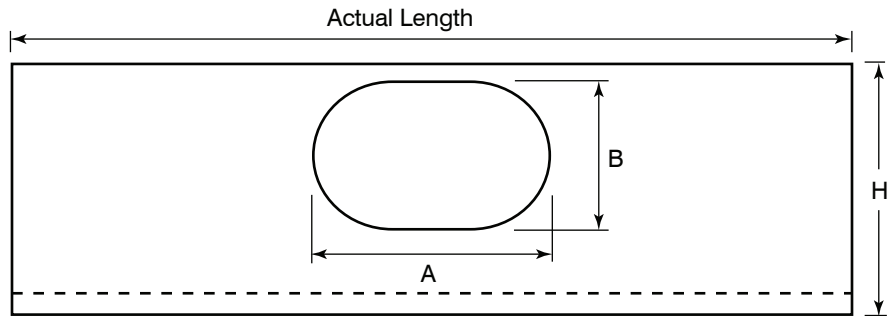
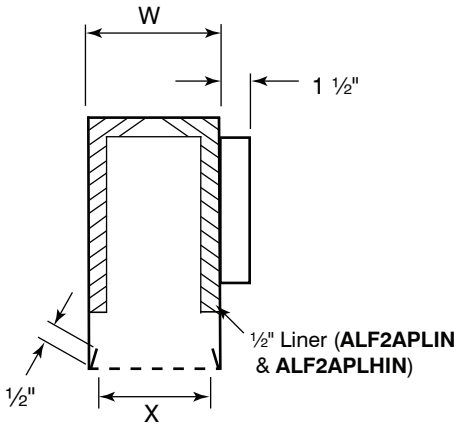


SUBMITTAL SHEET

 ALF2APL
H = 10"

 ALF2APLIN - 1/2" Liner Insulation
H = 10"

 ALF2APLH
H = 16"

 ALF2APLHIN - 1/2" Liner Insulation
H = 16"


✓	Inlet Size	With H=10"		With H=16"	
		A	B	A	B
	-08 8"	8"	8"	8"	8"
	-10 10"	10 15/16"	8"	10"	10"
	-12* 12"	14 3/32"	8"	12"	12"
	-14* 14"	17 1/2"	8"	14"	14"

✓	SLOTS WIDTH	W	X
	1"	5 11/16"	5 1/4"
	1 1/2"	7 11/16"	7 1/4"
	2"	9 11/16"	9 1/4"
	2 1/2"	11 11/16"	11 1/4"
	3"	13 11/16"	13 1/4"

ALS10/ALS18/ALS17 Mounting

<input type="checkbox"/> -E Surface	Actual Length = Nominal Length
<input type="checkbox"/> -T T-bar Lay-in	Actual Length = Nominal Length - 1/4"
<input type="checkbox"/> -P Plaster-in	Actual Length = Nominal Length

Schedule type: _____

Job: _____

Architect: _____

Engineer: _____

Contractor: _____

SUBMITTAL SHEET

ALF2PL / ALF2PLH / ALF2PLIN /
ALF2PLHIN Series

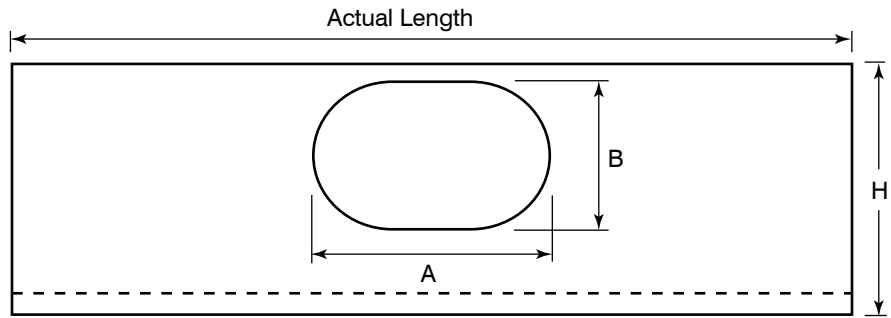
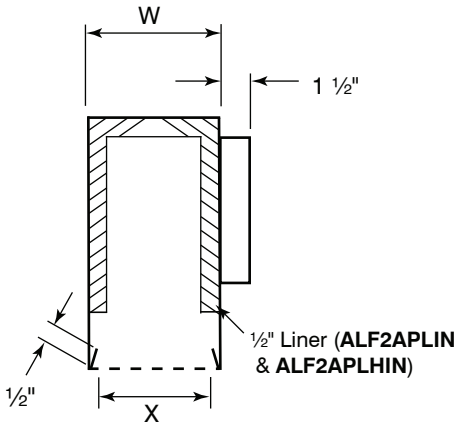
All dimensions are in inches

SUBMITTAL SHEET

Plenums for ALF Flow Bar Diffusers and Returns with 2 Slots

Material: 24 gauge galvalume

- | | |
|--|---|
| <input type="checkbox"/> ALF2APL
H = 10". Standard Plenum. | <input type="checkbox"/> ALF2APLIN
H = 10". Standard Plenum. - 1/2" Liner Insulation. |
| <input type="checkbox"/> ALF2APLH
H = 16". High Plenum. | <input type="checkbox"/> ALF2APLHIN
H = 16". High Plenum. - 1/2" Liner Insulation. |



✓	Inlet Size	With H=10"		With H=16"	
		A	B	A	B
	-08 8"	8"	8"	8"	8"
	-10 10"	10 15/16"	8"	10"	10"
	-12* 12"	14 3/32"	8"	12"	12"
	-14* 14"	17 1/2"	8"	14"	14"

✓	SLOTS WIDTH	W	X
	1"	5 11/16"	5 1/4"
	1 1/2"	7 11/16"	7 1/4"
	2"	9 11/16"	9 1/4"
	2 1/2"	11 11/16"	11 1/4"
	3"	13 11/16"	13 1/4"

ALS10/ALS18/ALS17 Mounting			
<input type="checkbox"/> -E Surface	Actual Length	=	Nominal Length
<input type="checkbox"/> -T T-bar Lay-in	Actual Length	=	Nominal Length - 1/4"
<input type="checkbox"/> -P Plaster-in	Actual Length	=	Nominal Length

Schedule type: _____

Job: _____

Architect: _____

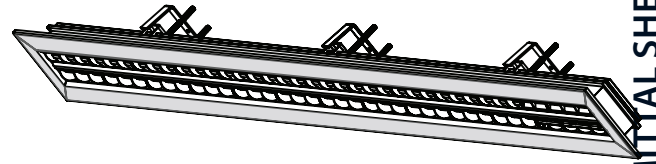
Engineer: _____

Contractor: _____

Linear Induction Nozzle Diffuser

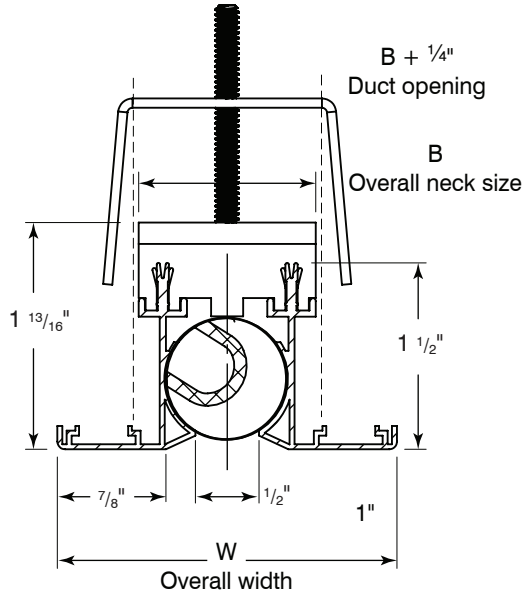
Material: Extruded aluminum construction,
Fire resistant polipropilen.

Mounting: Surface or Lay-in T-bar ceiling.

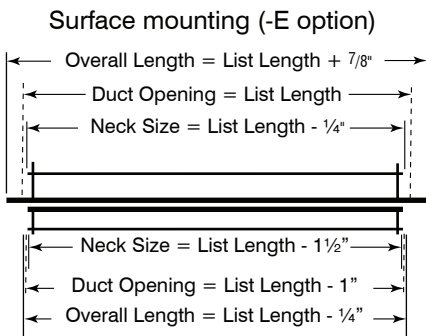


ALR

SUBMITTAL SHEET



-GK Frame Gasket



T-Bar mounting (-T option, N/A with -3)

✓	NO. OF SLOTS	B	W
	01	1 7/16"	2 3/4"
	02	2 1/2"	3 13/16"
	03	3 9/16"	4 7/8"
	04	4 5/8"	5 15/16"
	05	5 11/16"	7"
	06	6 3/4"	8"
	07	7 13/16"	9 1/9"
	08	8 7/8"	10 3/16"

Mounting	
<input type="checkbox"/> -E Surface Mounting 	<input type="checkbox"/> -T T-Bar mounting

Nozzle Color		
<input type="checkbox"/> /W White (Default)	<input type="checkbox"/> /BK Black	<input type="checkbox"/> /C Custom (Please Specify)

Finish		
<input type="checkbox"/> /W White (Default)	<input type="checkbox"/> /BK Black	<input type="checkbox"/> /C Custom (Please Specify)



Fastening Method		
<input type="checkbox"/> -1 No Fastening 	<input type="checkbox"/> -3 Screw Only with -T 	<input type="checkbox"/> -4 Concealed

Schedule type: _____

Job: _____

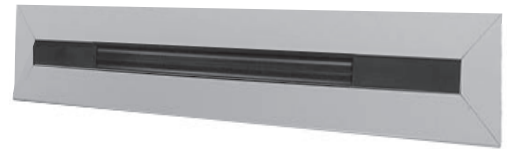
Architect: _____

Engineer: _____

Contractor: _____

Linear 1" Slot Diffuser

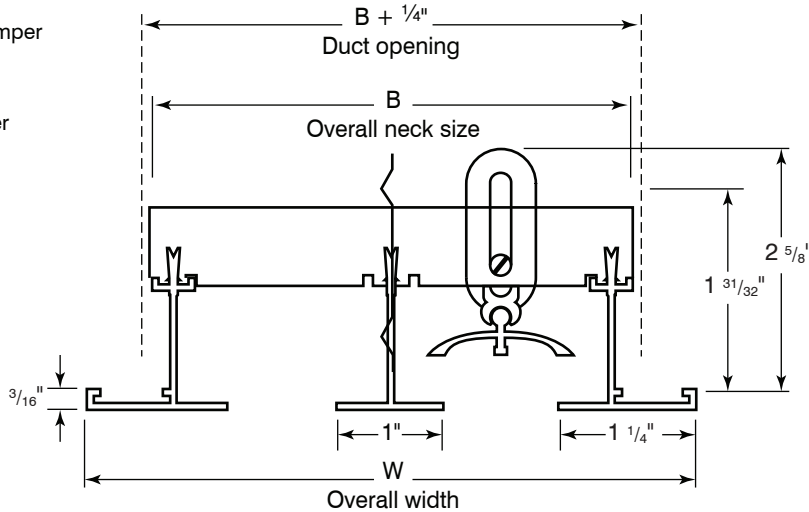
Material: Extruded aluminum construction
Mounting: Surface or Lay-in T-bar ceiling.
 Plaster-in Frame (Tape & Spackle)



ALS10 / ALS17

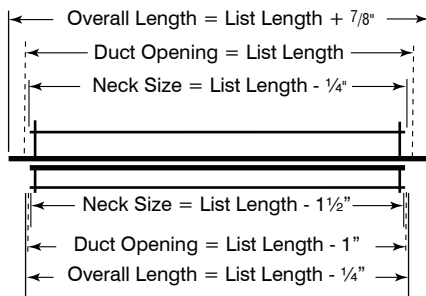
ALS10
without pattern-control damper

ALS17
with pattern-control damper



-GK Frame Gasket

Surface mounting (-E and -P options)



T-Bar mounting (-T option, N/A with -3)

✓	NO. OF SLOTS	B	W
	01	2 3/8"	3 1/2"
	02	4 3/8"	5 1/2"
	03	6 3/8"	7 1/2"
	04	8 3/8"	9 1/2"
	05	10 3/8"	11 1/2"
	06	12 3/8"	13 1/2"
	07	14 3/8"	15 1/2"
	08	16 3/8"	17 1/2"

Mounting		
<input type="checkbox"/> -P Plaster-In Frame 	<input type="checkbox"/> -E Surface Mounting 	<input type="checkbox"/> -T T-Bar mounting

Finish	
<input type="checkbox"/> /W White (Default)	<input type="checkbox"/> /C Custom (Please Specify)



Fastening Method			
<input type="checkbox"/> -1 No Fastening 	<input type="checkbox"/> -3 Screw Only with -T 	<input type="checkbox"/> -4 Concealed 	<input type="checkbox"/> -6 Adhesive tape tape

Schedule type: _____

Job: _____

Architect: _____

Engineer: _____

Contractor: _____

Plenums for ALF Flow Bar Diffusers and Returns with 1 Slot

Material: 20 gauge Aluminum.

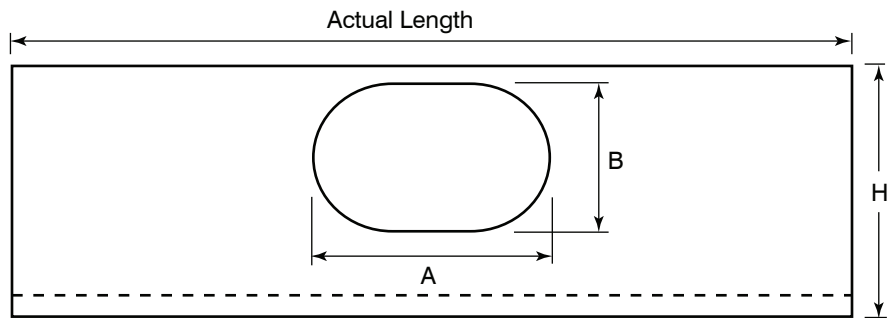
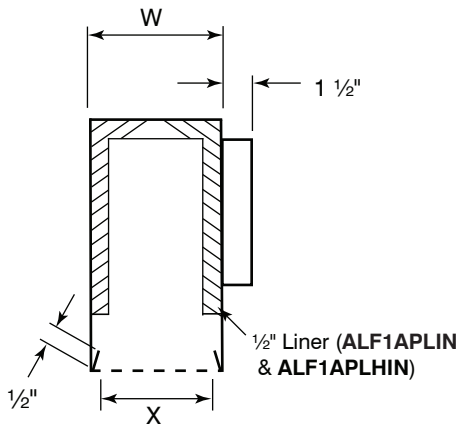


SUBMITTAL SHEET

 ALF1APL
 H = 8". Standard Plenum.

 ALF1APLIN - 1/2" Liner Insulation
 H = 8". Standard Plenum. - 1/2" Liner Insulation.

 ALF1APLH
 H = 11". High Plenum.

 ALF1APLHIN - 1/2" Liner Insulation
 H = 11". High Plenum. - 1/2" Liner Insulation.


✓	Inlet Size	With H=8"		With H=11"	
		A	B	A	B
	-04	4"	4"	-	-
	-05	5"	5"	-	-
	-06	6 1/4"	5 1/4"	6"	6"
	-08	9 3/8"	5 1/4"	9 3/8"	5 1/4"
	-08*	-	-	8"	8"
	-10	12 1/2"	5 1/4"	11"	8"
	-12**	-	-	14 1/8"	8"
	-14**	-	-	17 1/4"	8"

✓	Slots Width	W	X
	1"	3 3/8"	2 15/16"
	1 1/2"	4 3/8"	3 15/16"
	2"	5 3/8"	4 15/16"
	2 1/2"	6 3/8"	5 15/16"
	3"	7 3/8"	6 15/16"

*8" round neck available only with 11" high plenums

**12" & 14" oval neck available only with 11" high plenums

ALF10/ALF17/ALF18 Mounting

<input type="checkbox"/> -E Surface	Actual Length = Nominal Length
<input type="checkbox"/> -T T-bar Lay-in	Actual Length = Nominal Length - 1/4"
<input type="checkbox"/> -P Plaster-in	Actual Length = Nominal Length

Schedule type: _____

Job: _____

Architect: _____

Engineer: _____

Contractor: _____

SUBMITTAL SHEET

Linear 1" Linear Slot Diffuser - L-Shape

Material: Extruded aluminum construction

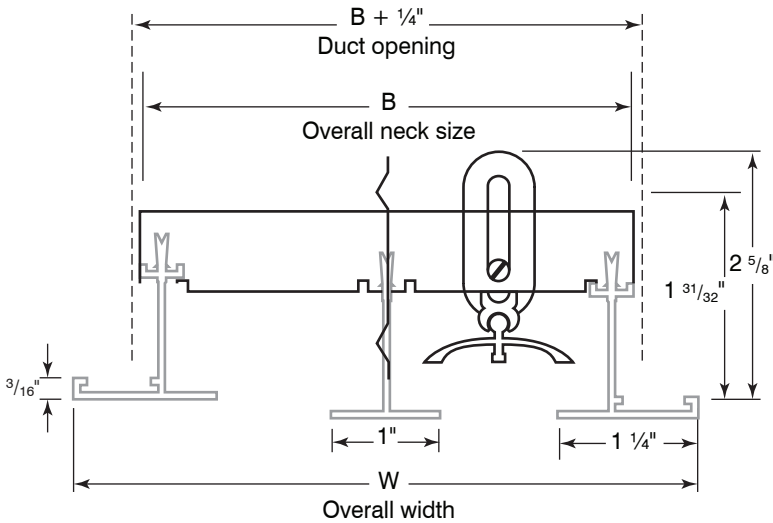
Mounting: Surface or Lay-in T-bar ceiling



ALS10 / ALS17
(ALS17 two slots shown here)
Corner Section
(No deflector in corner section)

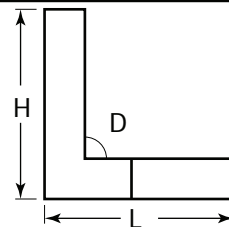
ALS10 (x=0)
without pattern-control damper

ALS17 (x=7)
with pattern-control damper



✓ NO. OF SLOTS	For -E and -T mounting type		For -P mounting type		C
	B	W	B'	W'	
01	2 3/8"	3 1/2"	2 13/16"	3 9/16"	12"
02	4 3/8"	5 1/2"	4 13/16"	5 9/16"	12"
03	6 3/8"	7 1/2"	6 13/16"	7 9/16"	12"
04	8 3/8"	9 1/2"	8 13/16"	9 9/16"	16"
05	10 3/8"	11 1/2"	10 13/16"	11 9/16"	16"
06	12 3/8"	13 1/2"	12 13/16"	13 9/16"	20"
07	14 3/8"	15 1/2"	14 13/16"	15 9/16"	20"
08	16 3/8"	17 1/2"	16 13/16"	17 9/16"	24"

Dimension



H (in inches): _____"
L (in inches): _____"
D (in degrees): _____°

Dimension Type (dd=FS, dd=LS or dd=NS)

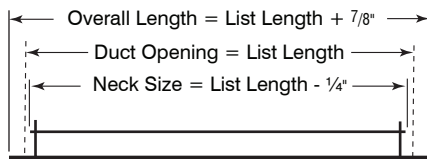
<input type="checkbox"/> -FS Face Size	<input type="checkbox"/> -LS List Size	<input type="checkbox"/> -NS Exact Neck Size
--	--	--

Supplied in species as follows:

- 1 pc. ALSEC1x-m-f-gg-dd HH #S /Finish
- 1 pc. ALSEC1x-m-f-gg-dd LL #S /Finish
- 1 pc. ALSMC1-m-f-gg-dd DD #S /Finish

-GK Frame Gasket (gg=GK)

Surface mounting (-E and -P options)



Mounting

<input type="checkbox"/> -P Plaster-In Frame 	<input type="checkbox"/> -E Surface Mounting 	<input type="checkbox"/> -T T-Bar mounting
---	---	---

Fastening Method

<input type="checkbox"/> -1 No Fastening 	<input type="checkbox"/> -3 Screw N/A with -T	<input type="checkbox"/> -4 Concealed
---	---	--

Finish

<input type="checkbox"/> /W White (Default)	<input type="checkbox"/> /C Custom (Please Specify) _____
---	---



Schedule type: _____

Job: _____

Architect: _____

Engineer: _____

Contractor: _____

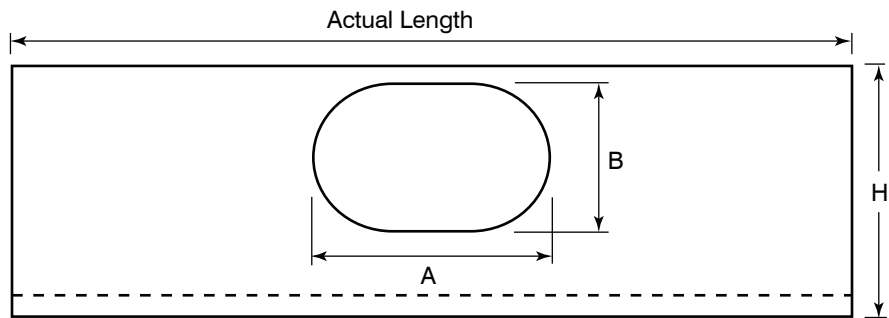
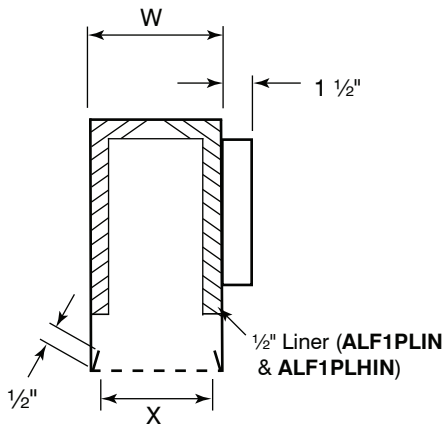
Plenums for ALF Flow Bar Diffusers and Returns with 1 Slot

Material: 24 gauge galvanized



SUBMITTAL SHEET

- | | |
|--|---|
| <input type="checkbox"/> ALF1PL
H = 8". Standard Plenum. | <input type="checkbox"/> ALF1PLIN
H = 8". Standard Plenum. - 1/2" Liner Insulation. |
| <input type="checkbox"/> ALF1PLH
H = 11". High Plenum. | <input type="checkbox"/> ALF1PLHIN
H = 11". High Plenum. - 1/2" Liner Insulation. |



✓	Inlet Size	With H=8"		With H=11"	
		A	B	A	B
	-04 4"	4"	4"	-	-
	-05 5"	5"	5"	-	-
	-06 6"	6 1/4"	5 1/4"	6"	6"
	-08 8"	9 3/8"	5 1/4"	9 3/8"	5 1/4"
	-08* 8"	-	-	8"	8"
	-10 10"	12 1/2"	5 1/4"	11"	8"
	-12** 12"	-	-	14 1/8"	8"
	-14** 14"	-	-	17 1/4"	8"

✓	Slots Width	W	X
	1"	3 3/8"	2 15/16"
	1 1/2"	4 3/8"	3 15/16"
	2"	5 3/8"	4 15/16"
	2 1/2"	6 3/8"	5 15/16"
	3"	7 3/8"	6 15/16"

*8" round neck available only with 11" high plenums

**12" & 14" oval neck available only with 11" high plenums

ALF10/ALF17/ALF18 Mounting

<input type="checkbox"/> -E Surface	Actual Length = Nominal Length
<input type="checkbox"/> -T T-bar Lay-in	Actual Length = Nominal Length - 1/4"
<input type="checkbox"/> -P Plaster-in	Actual Length = Nominal Length

Schedule type: _____

Job: _____

Architect: _____

Engineer: _____

Contractor: _____

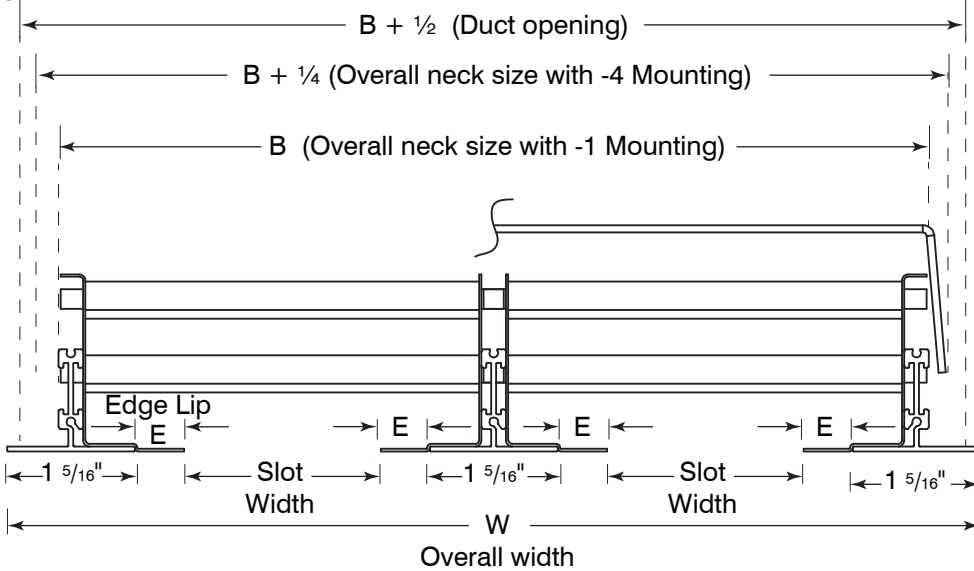
SUBMITTAL SHEET

Linear Flow Bar Diffuser - 2 Slot

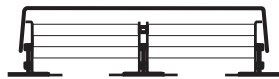
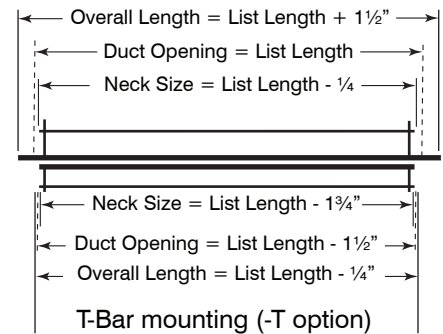
Material: Extruded aluminum construction
Mounting: Surface or Lay-in T-bar ceiling.
 Plaster-in Frame (Tape & Spackle)



ALF20 / ALF27 / ALF28 (ALF27 shown here)



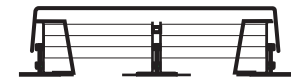
Surface mounting (-E and -P options)



ALF20
without pattern-control damper



ALF27
with high-flow slider



ALF28
with jet-flow baffles

Mounting		
<input type="checkbox"/> -P Plaster-In Frame	<input type="checkbox"/> -E Surface Mounting	<input type="checkbox"/> -T T-Bar mounting

Fastening Method		
<input type="checkbox"/> -1 No Fastening	<input type="checkbox"/> -3 Mounting Hole	<input type="checkbox"/> -4 Concealed

Option LS
Optional Return Hood/Light Shield Model

-LS

Finish	
<input type="checkbox"/> /W White (Default)	<input type="checkbox"/> /C Custom (Please Specify)



✓	Slot Width	B	W	C	E
	1"	4 7/8"	5 15/16"	1 1/2"	0"
	1 1/2"	6 7/8"	7 15/16"	1 1/2"	1/4"
	2"	8 7/8"	9 15/16"	1 3/4"	1/2"
	2 1/2"	10 7/8"	11 15/16"	1 3/4"	3/4"
	3"	12 7/8"	13 15/16"	1 3/4"	1"

Schedule type: _____

Job: _____

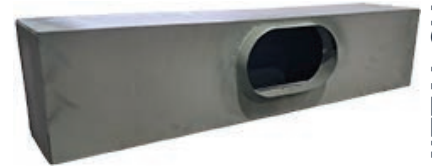
Architect: _____

Engineer: _____

Contractor: _____

Plenums for ALF Flow Bar Diffusers and Returns with 2 Slots

Material: 20 gauge Aluminum

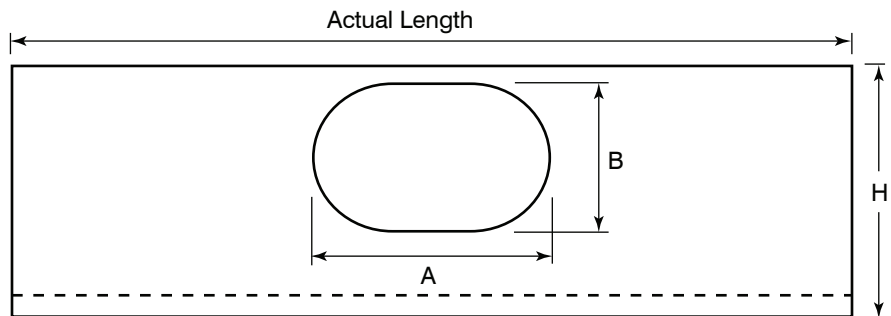
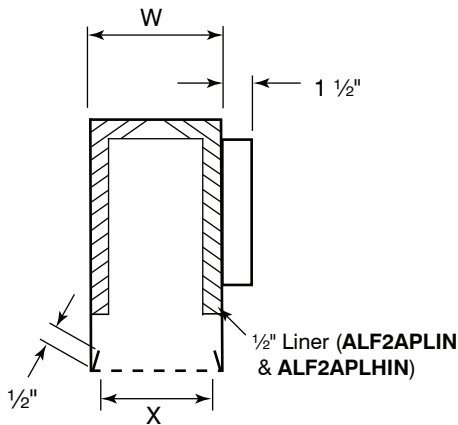


SUBMITTAL SHEET

 ALF2APL
H = 10"

 ALF2APLIN - 1/2" Liner Insulation
H = 10"

 ALF2APLH
H = 16"

 ALF2APLHIN - 1/2" Liner Insulation
H = 16"


✓	Inlet Size	With H=10"		With H=16"	
		A	B	A	B
	-08 8"	8"	8"	8"	8"
	-10 10"	10 15/16"	8"	10"	10"
	-12* 12"	14 3/32"	8"	12"	12"
	-14* 14"	17 1/2"	8"	14"	14"

✓	SLOTS WIDTH	W	X
	1"	5 11/16"	5 1/4"
	1 1/2"	7 11/16"	7 1/4"
	2"	9 11/16"	9 1/4"
	2 1/2"	11 11/16"	11 1/4"
	3"	13 11/16"	13 1/4"

ALS10/ALS18/ALS17 Mounting

<input type="checkbox"/> -E Surface	Actual Length = Nominal Length
<input type="checkbox"/> -T T-bar Lay-in	Actual Length = Nominal Length - 1/4"
<input type="checkbox"/> -P Plaster-in	Actual Length = Nominal Length

Schedule type: _____

Job: _____

Architect: _____

Engineer: _____

Contractor: _____

SUBMITTAL SHEET

ALF2PL / ALF2PLH / ALF2PLIN / ALF2PLHIN Series

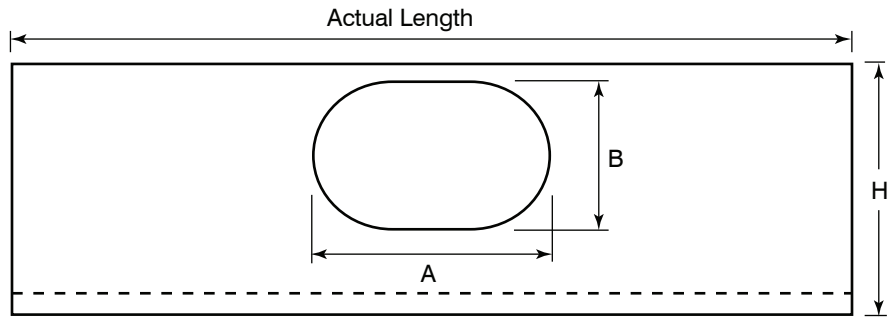
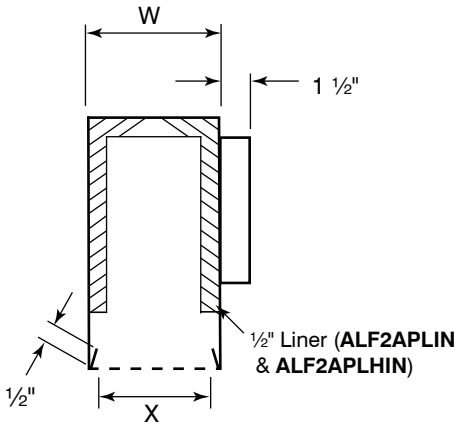
All dimensions are in inches

SUBMITTAL SHEET

Plenums for ALF Flow Bar Diffusers and Returns with 2 Slots

Material: 24 gauge galvalneal

- | | |
|--|---|
| <input type="checkbox"/> ALF2APL
H = 10". Standard Plenum. | <input type="checkbox"/> ALF2APLIN
H = 10". Standard Plenum. - 1/2" Liner Insulation. |
| <input type="checkbox"/> ALF2APLH
H = 16". High Plenum. | <input type="checkbox"/> ALF2APLHIN
H = 16". High Plenum. - 1/2" Liner Insulation. |



✓	Inlet Size	With H=10"		With H=16"	
		A	B	A	B
	-08 8"	8"	8"	8"	8"
	-10 10"	10 15/16"	8"	10"	10"
	-12* 12"	14 3/32"	8"	12"	12"
	-14* 14"	17 1/2"	8"	14"	14"

✓	SLOTS WIDTH	W	X
	1"	5 11/16"	5 1/4"
	1 1/2"	7 11/16"	7 1/4"
	2"	9 11/16"	9 1/4"
	2 1/2"	11 11/16"	11 1/4"
	3"	13 11/16"	13 1/4"

ALS10/ALS18/ALS17 Mounting			
<input type="checkbox"/> -E Surface	Actual Length	=	Nominal Length
<input type="checkbox"/> -T T-bar Lay-in	Actual Length	=	Nominal Length - 1/4"
<input type="checkbox"/> -P Plaster-in	Actual Length	=	Nominal Length

Schedule type: _____

Job: _____

Architect: _____

Engineer: _____

Contractor: _____

Linear 3/4" Slot Diffuser

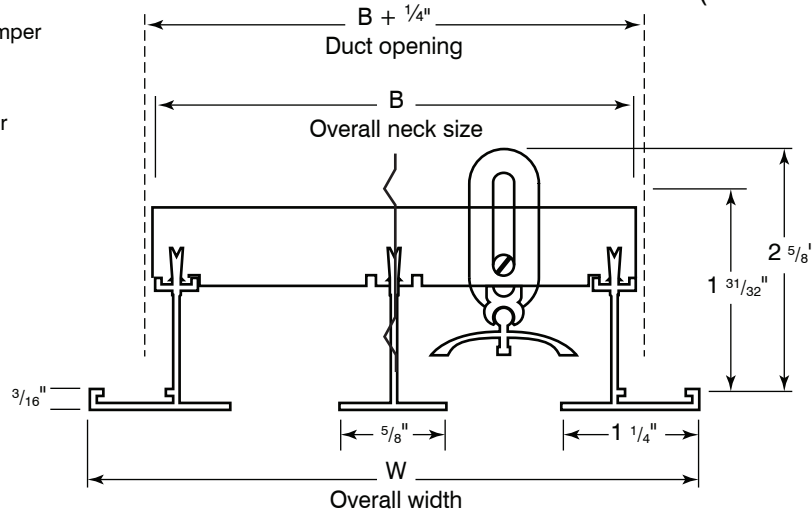
Material: Extruded aluminum construction
Mounting: Surface or Lay-in T-bar ceiling.
 Plaster-in Frame (Tape & Spackle)



ALS30 / ALS37
 (ALS27 two slots shown here)

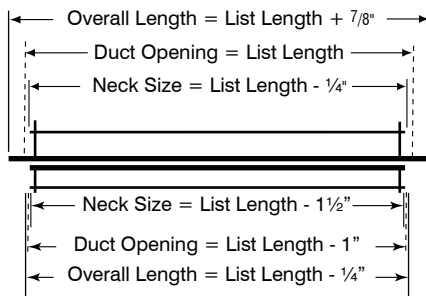
ALS30
 without pattern-control damper

ALS37
 with pattern-control damper



-GK Frame Gasket

Surface mounting (-E and -P options)



T-Bar mounting (-T option, N/A with -3)

✓ NO. OF SLOTS	For -E and -T mounting type		For -P mounting type	
	B	W	B'	W'
01	1 13/16"	2 15/16"	2 1/8"	3 1/4"
02	3 1/4"	4 3/8"	3 1/2"	4 3/8"
03	4 11/16"	5 13/16"	4 7/8"	6"
04	6 1/8"	7 1/4"	6 1/4"	7 3/8"
05	7 9/16"	8 11/16"	7 5/8"	8 3/4"
06	9"	10 1/8"	9 3/8"	10 1/8"
07	10 7/16"	11 9/16"	10 13/16"	11 9/16"
08	11 7/8"	13"	12 1/4"	13"

Mounting		
<input type="checkbox"/> -P Plaster-In Frame 	<input type="checkbox"/> -E Surface Mounting 	<input type="checkbox"/> -T T-Bar mounting

Fastening Method			
<input type="checkbox"/> -1 No Fastening 	<input type="checkbox"/> -3 Screw Only with -T 	<input type="checkbox"/> -4 Concealed 	<input type="checkbox"/> -6 Adhesive tape tape

Finish	
<input type="checkbox"/> /W White (Default)	<input type="checkbox"/> /C Custom (Please Specify)



Schedule type: _____

Job: _____

Architect: _____

Engineer: _____

Contractor: _____

Plenums for ALS30/37 - 3/4" Slot Diffusers and Returns

Material: 20 gauge aluminum.

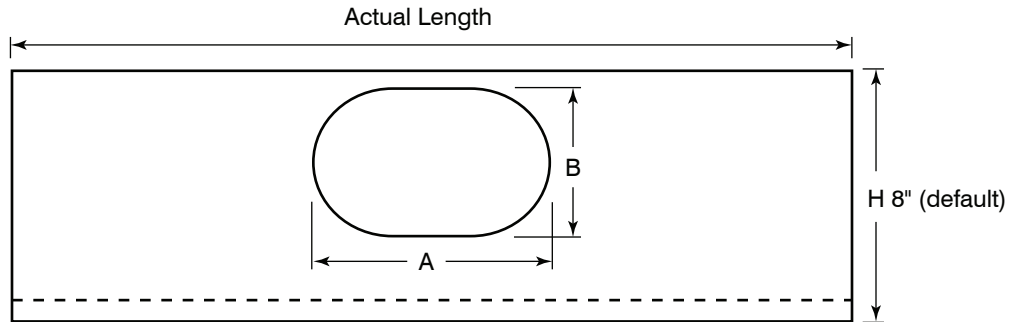
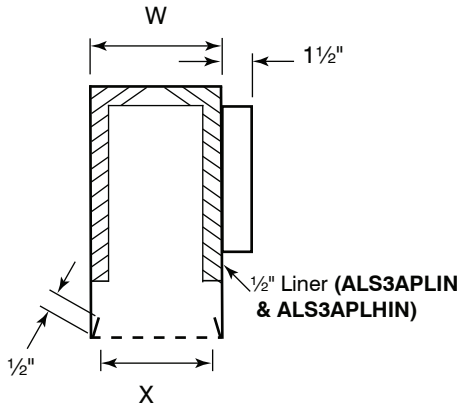


ALS3APL
 H = 8". Standard Plenum.

ALS3APLIN
 H = 8". Standard Plenum. - 1/2" Liner Insulation.

ALS3APLH
 H = 11". High Plenum.

ALS3APLHIN
 H = 11". High Plenum. - 1/2" Liner Insulation.



Standard Plenum. H = 8" (default)

✓		Inlet Size	Neck Shape	A	B
	-04	4"	○	4"	4"
	-05	5"	○	5"	5"
	-06	6"	○	6"	6"
	-08	8"	○	9 3/8"	5 1/4"
	-10	10"	○	14"	5 1/4"

High Plenum. H = 11"

✓		Inlet Size	Neck Shape	A	B
	-08	8"	○	8"	8"
	-10	10"	○	14"	5 1/4"
	-12	12"	○	13 1/2"	8 1/2"
	-14	14"	○	17 1/2"	8 1/2"
	-16	16"	○	22 1/2"	8 1/2"

✓	NO. OF SLOTS	For -E and -T mounting type		For -P mounting type	
		X	W	X'	W'
	01	2 1/16"	2 7/16"	2 11/16"	3 1/16"
	02	3 1/2"	3 7/8"	4 1/8"	4 1/2"
	03	4 15/16"	5 5/16"	5 5/8"	6"
	04	6 3/8"	6 3/4"	7 1/16"	7 7/16"
	05	7 13/16"	8 3/16"	8 1/2"	8 7/16"
	06	9 1/4"	9 5/8"	9 15/16"	10 5/16"
	07	10 11/16"	11 1/16"	11 3/8"	11 6/8"
	08	12 1/8"	12 1/2"	12 7/8"	13 1/4"

Options

-AN Angled Plenums

ALS30/ALS37 Mounting

<input type="checkbox"/> -E Surface	Actual Length = Nominal Length
<input type="checkbox"/> -T T-bar Lay-in	Actual Length = Nominal Length - 1 1/8"
<input type="checkbox"/> -P Plaster-in	Actual Length = Nominal Length

-Rxx Option. Variable Height Plenum For Round Collar > 8"

✓		Inlet Size	Neck Shape	A	B	H	Dimensions
	-R10	10"	○	10"	10"	13"	(available for collar > 8")
	-R12	12"	○	12"	12"	15"	
	-R14	14"	○	14"	14"	17"	
	-R16	16"	○	16"	16"	19"	

Schedule type: _____

Job: _____

Architect: _____

Engineer: _____

Contractor: _____

Plenums for ALS30/37 - 3/4" Slot Diffusers and Returns

Material: 24 gauge galvaneal.

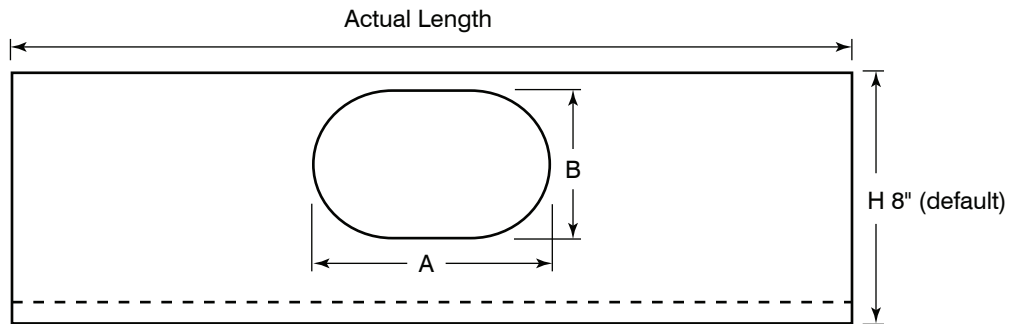
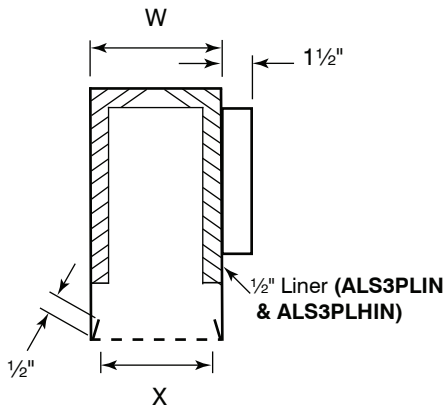


SUBMITTAL SHEET

 ALS3PL
H = 8". Standard Plenum.

 ALS3PLIN
H = 8". Standard Plenum. - 1/2" Liner Insulation.

 ALS3PLH
H = 11". High Plenum.

 ALS3PLHIN
H = 11". High Plenum. - 1/2" Liner Insulation.


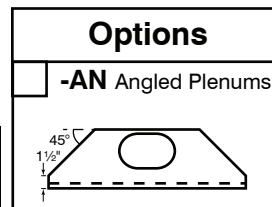
Standard Plenum. H = 8" (default)

✓		Inlet Size	Neck Shape	A	B
	-04	4"	○	4"	4"
	-05	5"	○	5"	5"
	-06	6"	○	6"	6"
	-08	8"	○	9 3/8"	5 1/4"
	-10	10"	○	14"	5 1/4"

High Plenum. H = 11"

✓		Inlet Size	Neck Shape	A	B
	-08	8"	○	8"	8"
	-10	10"	○	14"	5 1/4"
	-12	12"	○	13 1/2"	8 1/2"
	-14	14"	○	17 1/2"	8 1/2"
	-16	16"	○	22 1/2"	8 1/2"

✓	NO. OF SLOTS	For -E and -T mounting type		For -P mounting type	
		X	W	X'	W'
	01	2 1/16"	2 7/16"	2 11/16"	3 1/16"
	02	3 1/2"	3 7/8"	4 1/8"	4 1/2"
	03	4 15/16"	5 5/16"	5 5/8"	6"
	04	6 3/8"	6 3/4"	7 1/16"	7 7/16"
	05	7 13/16"	8 3/16"	8 1/2"	8 7/16"
	06	9 1/4"	9 5/8"	9 15/16"	10 5/16"
	07	10 11/16"	11 1/16"	11 3/8"	11 6/8"
	08	12 1/8"	12 1/2"	12 7/8"	13 1/4"



ALS30/ALS37 Mounting		
<input type="checkbox"/> -E Surface	Actual Length =	Nominal Length
<input type="checkbox"/> -T T-bar Lay-in	Actual Length =	Nominal Length - 1 1/8"
<input type="checkbox"/> -P Plaster-in	Actual Length =	Nominal Length

-Rxx Option. Variable Height Plenum For Round Collar > 8"

✓		Inlet Size	Neck Shape	A	B	H	Dimensions
	-R10	10"	○	10"	10"	13"	(available for collar > 8")
	-R12	12"	○	12"	12"	15"	
	-R14	14"	○	14"	14"	17"	
	-R16	16"	○	16"	16"	19"	

Schedule type: _____

Job: _____

Architect: _____

Engineer: _____

Contractor: _____

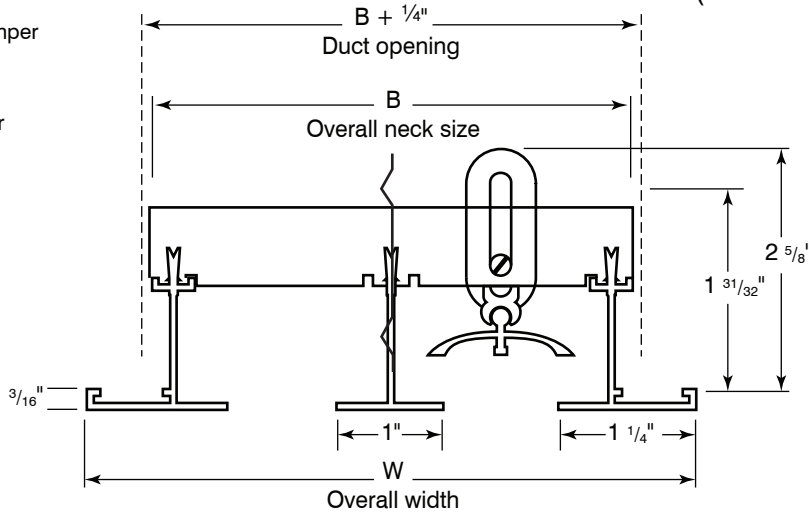
Linear 1 1/4" Slot Diffuser

Material: Extruded aluminum construction
Mounting: Surface or Lay-in T-bar ceiling.
 Plaster-in Frame (Tape & Spackle)



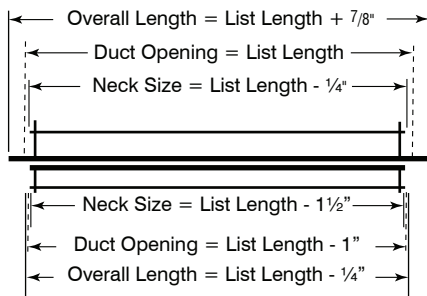
ALS40 / ALS47
 (ALS27 two slots shown here)

- ALS40**
without pattern-control damper
- ALS47**
with pattern-control damper



- GK Frame Gasket**

Surface mounting (-E and -P options)



T-Bar mounting (-T option, N/A with -3)

✓ NO. OF SLOTS	B	W
01	2 5/8"	3 3/4"
02	4 7/8"	6"
03	7 1/8"	8 1/4"
04	9 3/8"	10 1/2"
05	11 5/8"	12 3/4"
06	13 7/8"	15"
07	16 1/8"	17 1/4"
08	18 3/8"	19 1/2"

Mounting		
<input type="checkbox"/> -P Plaster-In Frame 	<input type="checkbox"/> -E Surface Mounting 	<input type="checkbox"/> -T T-Bar mounting

Finish	
<input type="checkbox"/> /W White (Default)	<input type="checkbox"/> /C Custom (Please Specify)



Fastening Method			
<input type="checkbox"/> -1 No Fastening 	<input type="checkbox"/> -3 Screw Only with -T 	<input type="checkbox"/> -4 Concealed 	<input type="checkbox"/> -6 Adhesive tape tape

Schedule type: _____

Job: _____

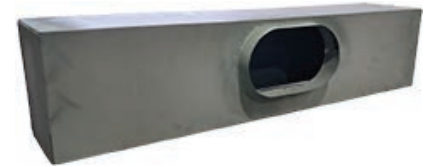
Architect: _____

Engineer: _____

Contractor: _____

Plenums for ALS40/47 - 1 1/4" Slot Diffusers and Returns

Material: 20 gauge aluminum.

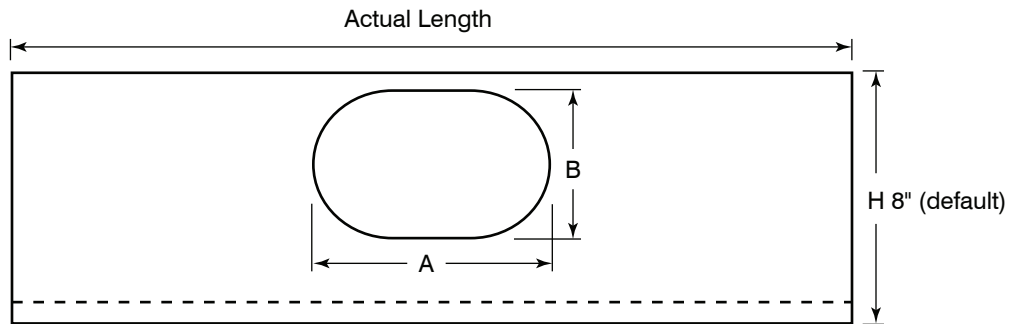
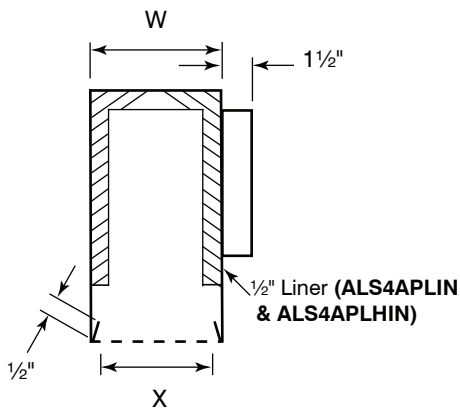


SUBMITTAL SHEET

 ALS4APL
H = 8". Standard Plenum.

 ALS4APLIN
H = 8". Standard Plenum. - 1/2" Liner Insulation.

 ALS4APLH
H = 11". High Plenum.

 ALS4APLHIN
H = 11". High Plenum. - 1/2" Liner Insulation.


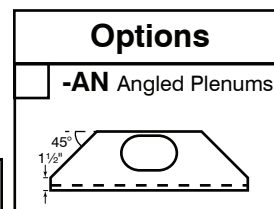
Standard Plenum. H = 8" (default)

✓		Inlet Size	Neck Shape	A	B
	-04	4"	○	4"	4"
	-05	5"	○	5"	5"
	-06	6"	○	6"	6"
	-08	8"	○	9 3/8"	5 1/4"
	-10	10"	○	14"	5 1/4"

High Plenum. H = 11"

✓		Inlet Size	Neck Shape	A	B
	-08	8"	○	8"	8"
	-10	10"	○	14"	5 1/4"
	-12	12"	○	13 1/2"	8 1/2"
	-14	14"	○	17 1/2"	8 1/2"
	-16	16"	○	22 1/2"	8 1/2"

✓	NO. OF SLOTS	X	W
	01	2 7/8"	3 3/8"
	02	5 1/8"	5 1/2"
	03	7 3/8"	7 3/4"
	04	9 5/8"	10"
	05	11 7/8"	12 2/8"
	06	14 1/8"	14 1/2"
	07	16 3/8"	16 3/4"
	08	18 5/8"	19"



ALS10/ALS17 Mounting

<input type="checkbox"/> -E Surface	Actual Length = Nominal Length
<input type="checkbox"/> -T T-bar Lay-in	Actual Length = Nominal Length - 1 1/8"
<input type="checkbox"/> -P Plaster-in	Actual Length = Nominal Length

-Rxx Option. Variable Height Plenum For Round Collar > 8"

✓		Inlet Size	Neck Shape	A	B	H	Dimensions
	-R10	10"	○	10"	10"	13"	(available for collar > 8")
	-R12	12"	○	12"	12"	15"	
	-R14	14"	○	14"	14"	17"	
	-R16	16"	○	16"	16"	19"	

Schedule type: _____

Job: _____

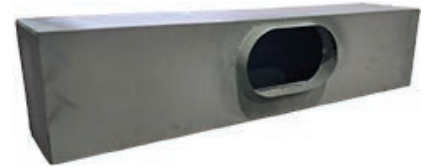
Architect: _____

Engineer: _____

Contractor: _____

Plenums for ALS40/47 - 1 1/4" Slot Diffusers and Returns

Material: 24 gauge galvalneal.

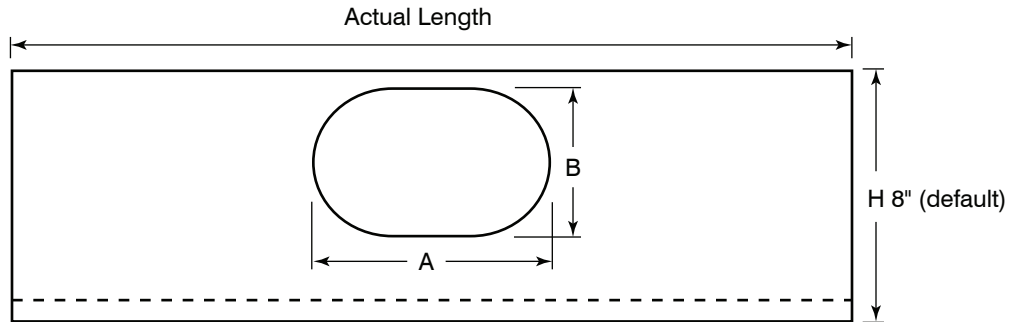
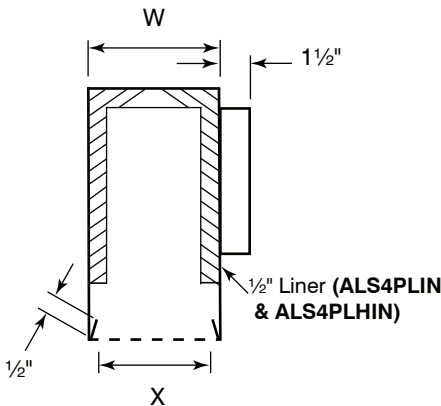


ALS4PL
H = 8". Standard Plenum.

ALS4PLIN
H = 8". Standard Plenum. - 1/2" Liner Insulation.

ALS4PLH
H = 11". High Plenum.

ALS4PLHIN
H = 11". High Plenum. - 1/2" Liner Insulation.



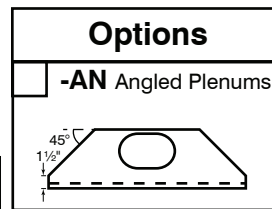
Standard Plenum. H = 8" (default)

✓		Inlet Size	Neck Shape	A	B
	-04	4"	○	4"	4"
	-05	5"	○	5"	5"
	-06	6"	○	6"	6"
	-08	8"	○	9 3/8"	5 1/4"
	-10	10"	○	14"	5 1/4"

High Plenum. H = 11"

✓		Inlet Size	Neck Shape	A	B
	-08	8"	○	8"	8"
	-10	10"	○	14"	5 1/4"
	-12	12"	○	13 1/2"	8 1/2"
	-14	14"	○	17 1/2"	8 1/2"
	-16	16"	○	22 1/2"	8 1/2"

✓	NO. OF SLOTS	X	W
	01	2 7/8"	3 3/8"
	02	5 1/8"	5 1/2"
	03	7 3/8"	7 3/4"
	04	9 5/8"	10"
	05	11 7/8"	12 2/8"
	06	14 1/8"	14 1/2"
	07	16 3/8"	16 3/4"
	08	18 5/8"	19"



ALS10/ALS17 Mounting

<input type="checkbox"/> -E Surface	Actual Length = Nominal Length
<input type="checkbox"/> -T T-bar Lay-in	Actual Length = Nominal Length - 1 1/8"
<input type="checkbox"/> -P Plaster-in	Actual Length = Nominal Length

-Rxx Option. Variable Height Plenum For Round Collar > 8"

✓		Inlet Size	Neck Shape	A	B	H	Dimensions
	-R10	10"	○	10"	10"	13"	(available for collar > 8")
	-R12	12"	○	12"	12"	15"	
	-R14	14"	○	14"	14"	17"	
	-R16	16"	○	16"	16"	19"	

Schedule type: _____

Job: _____

Architect: _____

Engineer: _____

Contractor: _____

Linear 1½" Slot Diffuser

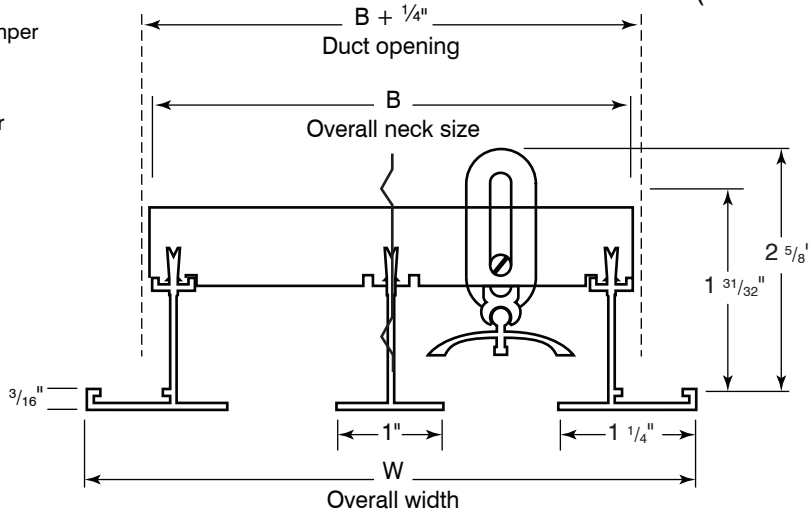
Material: Extruded aluminum construction
Mounting: Surface or Lay-in T-bar ceiling.
 Plaster-in Frame (Tape & Spackle)



ALS50 / ALS57
 (ALS27 two slots shown here)

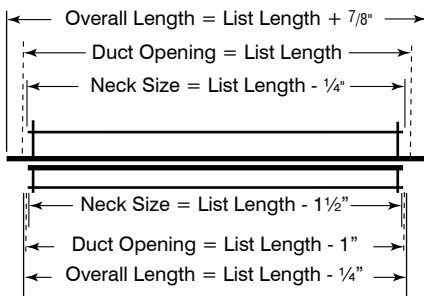
ALS50
 without pattern-control damper

ALS57
 with pattern-control damper



-GK Frame Gasket

Surface mounting (-E and -P options)



T-Bar mounting (-T option, N/A with -3)

✓	NO. OF SLOTS	B	W
	01	2 7/8"	4"
	02	5 3/8"	6 1/2"
	03	7 7/8"	9"
	04	10 3/8"	11 1/2"
	05	12 7/8"	14"
	06	15 3/8"	16 1/2"
	07	17 7/8"	19"
	08	20 3/8"	21 1/2"

Mounting		
<input type="checkbox"/> -P Plaster-In Frame 	<input type="checkbox"/> -E Surface Mounting 	<input type="checkbox"/> -T T-Bar mounting

Finish	
<input type="checkbox"/> /W White (Default)	<input type="checkbox"/> /C Custom (Please Specify)



Fastening Method			
<input type="checkbox"/> -1 No Fastening 	<input type="checkbox"/> -3 Screw Only with -T 	<input type="checkbox"/> -4 Concealed 	<input type="checkbox"/> -6 Adhesive tape tape

Schedule type: _____

Job: _____

Architect: _____

Engineer: _____

Contractor: _____

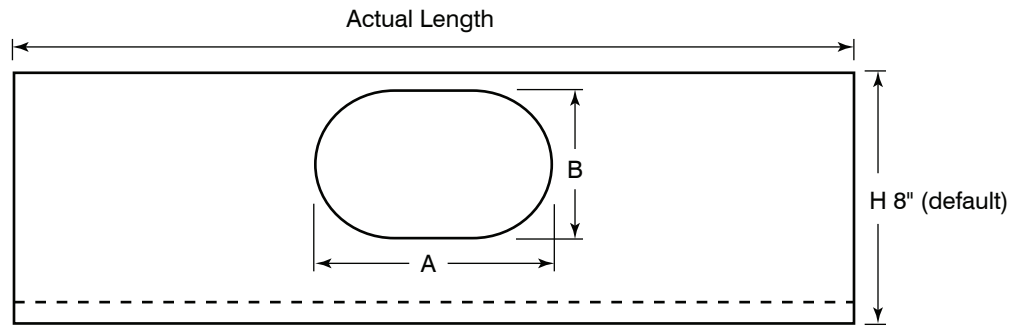
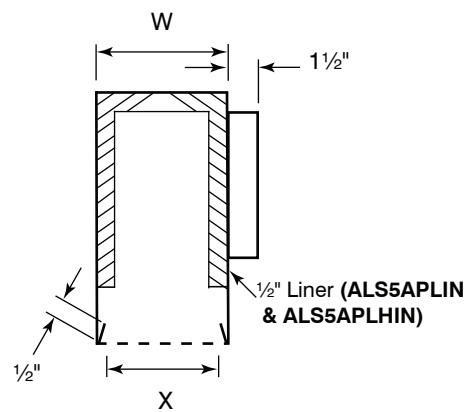
SUBMITTAL SHEET

Plenums for ALS50/57 - 1 1/2" Slot Diffusers and Returns

Material: 20 gauge aluminum.



- ALS5APL**
H = 8". Standard Plenum.
- ALS5APLH**
H = 11". High Plenum.
- ALS5APLIN**
H = 8". Standard Plenum. - 1/2" Liner Insulation.
- ALS5APLHIN**
H = 11". High Plenum. - 1/2" Liner Insulation.



Standard Plenum. H = 8" (default)

✓		Inlet Size	Neck Shape	A	B
	-04	4"	○	4"	4"
	-05	5"	○	5"	5"
	-06	6"	○	6"	6"
	-08	8"	○	9 3/8"	5 1/4"
	-10	10"	○	14"	5 1/4"

High Plenum. H = 11"

✓		Inlet Size	Neck Shape	A	B
	-08	8"	○	8"	8"
	-10	10"	○	14"	5 1/4"
	-12	12"	○	13 1/2"	8 1/2"
	-14	14"	○	17 1/2"	8 1/2"
	-16	16"	○	22 1/2"	8 1/2"

✓	NO. OF SLOTS	X	W
	01	3 1/8"	3 1/2"
	02	5 5/8"	6"
	03	8 1/8"	8 1/2"
	04	10 5/8"	11"
	05	13 1/8"	13 1/2"
	06	15 5/8"	16"
	07	18 1/8"	18 1/2"
	08	20 5/8"	21"

Options

-AN Angled Plenums

ALS10/ALS17 Mounting		
<input type="checkbox"/> -E Surface	Actual Length =	Nominal Length
<input type="checkbox"/> -T T-bar Lay-in	Actual Length =	Nominal Length - 1 1/8"
<input type="checkbox"/> -P Plaster-in	Actual Length =	Nominal Length

-Rxx Option. Variable Height Plenum For Round Collar > 8"

✓		Inlet Size	Neck Shape	A	B	H	Dimensions
	-R10	10"	○	10"	10"	13"	(available for collar > 8")
	-R12	12"	○	12"	12"	15"	
	-R14	14"	○	14"	14"	17"	
	-R16	16"	○	16"	16"	19"	

Schedule type: _____

Job: _____

Architect: _____

Engineer: _____

Contractor: _____

Plenums for ALS50/57 - 1 1/2" Slot Diffusers and Returns

Material: 24 gauge galvalume.

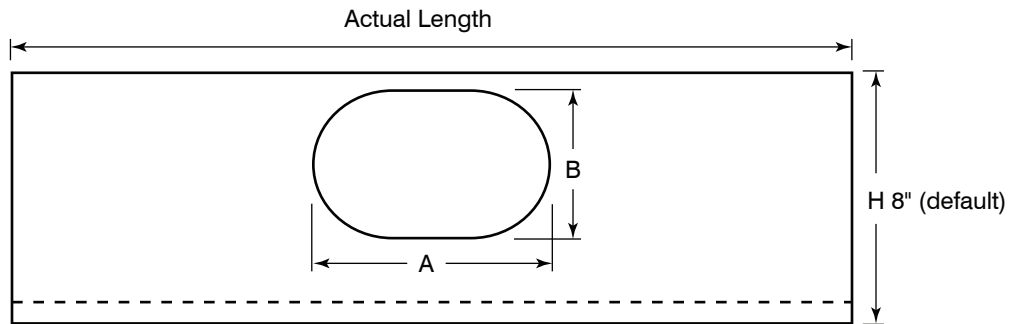
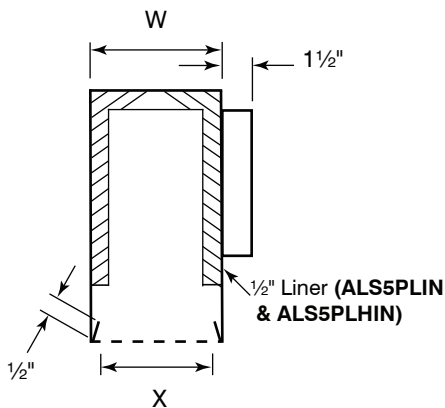


SUBMITTAL SHEET

 ALS5PL
 H = 8". Standard Plenum.

 ALS5PLIN
 H = 8". Standard Plenum. - 1/2" Liner Insulation.

 ALS5PLH
 H = 11". High Plenum.

 ALS5PLHIN
 H = 11". High Plenum. - 1/2" Liner Insulation.


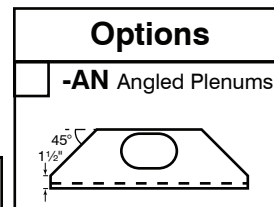
Standard Plenum. H = 8" (default)

✓		Inlet Size	Neck Shape	A	B
	-04	4"	○	4"	4"
	-05	5"	○	5"	5"
	-06	6"	○	6"	6"
	-08	8"	○	9 3/8"	5 1/4"
	-10	10"	○	14"	5 1/4"

High Plenum. H = 11"

✓		Inlet Size	Neck Shape	A	B
	-08	8"	○	8"	8"
	-10	10"	○	14"	5 1/4"
	-12	12"	○	13 1/2"	8 1/2"
	-14	14"	○	17 1/2"	8 1/2"
	-16	16"	○	22 1/2"	8 1/2"

✓	NO. OF SLOTS	X	W
	01	3 1/8"	3 1/2"
	02	5 5/8"	6"
	03	8 1/8"	8 1/2"
	04	10 5/8"	11"
	05	13 1/8"	13 1/2"
	06	15 5/8"	16"
	07	18 1/8"	18 1/2"
	08	20 5/8"	21"



ALS10/ALS17 Mounting

<input type="checkbox"/> -E Surface	Actual Length = Nominal Length
<input type="checkbox"/> -T T-bar Lay-in	Actual Length = Nominal Length - 1 1/8"
<input type="checkbox"/> -P Plaster-in	Actual Length = Nominal Length

-Rxx Option. Variable Height Plenum For Round Collar > 8"

✓		Inlet Size	Neck Shape	A	B	H	Dimensions
	-R10	10"	○	10"	10"	13"	(available for collar > 8")
	-R12	12"	○	12"	12"	15"	
	-R14	14"	○	14"	14"	17"	
	-R16	16"	○	16"	16"	19"	

Schedule type: _____

Job: _____

Architect: _____

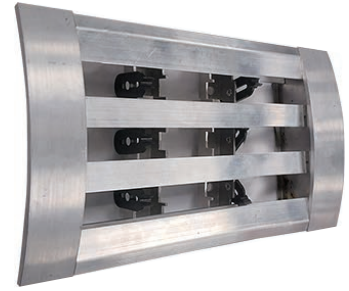
Engineer: _____

Contractor: _____

SUBMITTAL SHEET

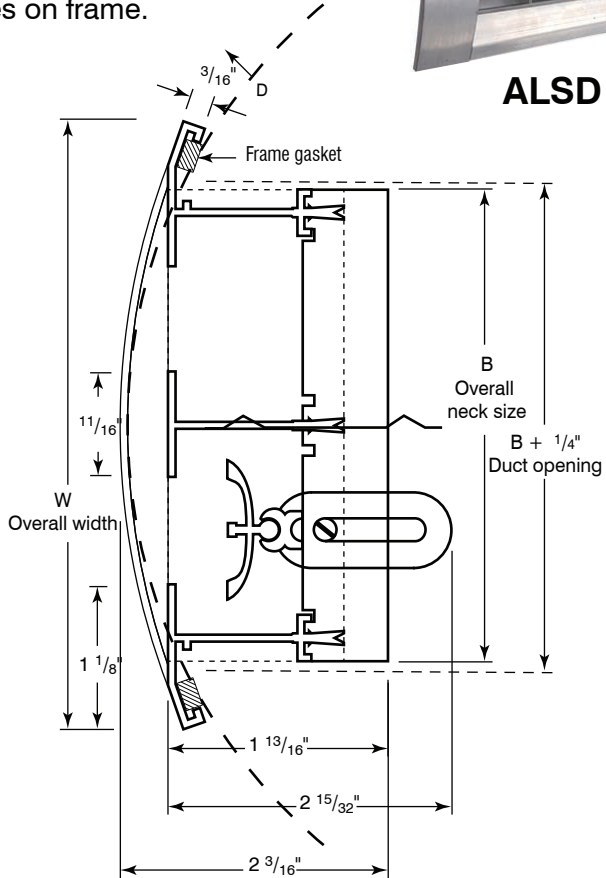
Spiral Duct Linear 1" Slot Diffuser

Material: Extruded aluminum construction.
Mounting: Surface for round ducts.
Finish: Powder paint coating - white.
Fastening Method: Countersunk mounting holes on frame.



ALSD

- ALSD10**
without pattern-control damper
- ALSD17**
with pattern-control damper
- ALSD18**
with air scoop



✓	NO. OF SLOTS	B	W
	01	2 3/8"	2 5/8"
	02	4 3/8"	4 5/8"
	03	6 3/8"	6 5/8"
	04	8 3/8"	8 5/8"

✓	Duct D	Duct cut out opening			
		1 slot	2 slots	3 slots	4 slots
	10	2 3/8"	4 1/2"		
	12	2 3/8"	4 1/2"		
	14	2 3/8"	4 1/2"	6 5/8"	
	16	2 3/8"	4 1/2"	6 1/2"	8 3/4"
	18	2 3/8"	4 3/8"	6 1/2"	8 3/4"
	20	2 3/8"	4 3/8"	6 1/2"	8 5/8"
	24	2 3/8"	4 3/8"	6 1/2"	8 1/2"
	30	2 3/8"	4 3/8"	6 3/8"	8 1/2"
	40&over	2 3/8"	4 3/8"	6 3/8"	8 1/2"

Finish	
<input type="checkbox"/> /W White (Default)	<input type="checkbox"/> /C Custom (Please Specify)



Schedule type: _____

Job: _____

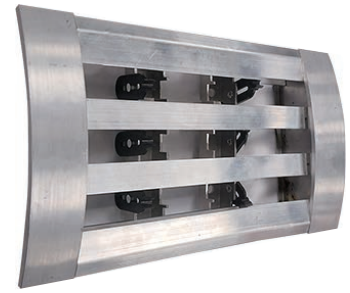
Architect: _____

Engineer: _____

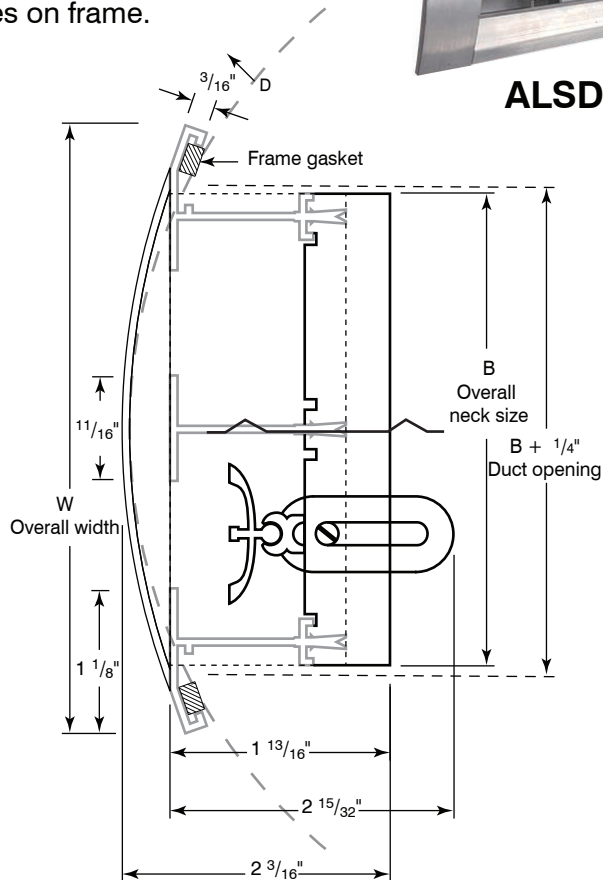
Contractor: _____

Linear 1/2" Slot Diffuser for Round Ducts

Material: Extruded aluminum construction.
Mounting: Surface for round ducts.
Finish: Powder paint coating - white.
Fastening Method: Countersunk mounting holes on frame.


ALSD

- ALSD20**
without pattern-control damper
- ALSD27**
with pattern-control damper
- ALSD28**
with air scoop



✓	NO. OF SLOTS	B	W
	01	2 9/16"	2 13/16"
	02	2 3/4"	3"
	03	3 15/16"	4 3/16"
	04	5 1/4"	5 1/2"

✓	Duct D	Duct cut out opening			
		1 slot	2 slots	3 slots	4 slots
	10	2 9/16"	2 5/8"		
	12	2 9/16"	2 5/8"		
	14	2 9/16"	2 5/8"	3 1/2"	
	16	2 9/16"	2 3/4"	3 3/8"	5 5/8"
	18	2 9/16"	2 3/4"	3 3/8"	5 5/8"
	20	2 9/16"	2 3/4"	3 3/8"	5 1/2"
	24	2 9/16"	2 3/4"	3 3/8"	5 3/8"
	30	2 9/16"	2 3/4"	3 15/16"	5 3/8"
	40&over	2 9/16"	2 3/4"	3 15/16"	5 3/8"

Finish	
<input type="checkbox"/> /W White (Default)	<input type="checkbox"/> /C Custom (Please Specify)

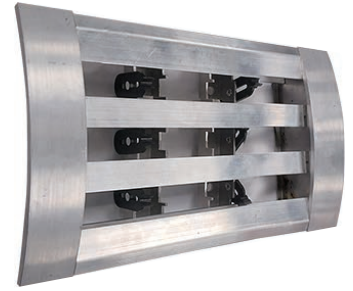


Schedule type: _____
 Job: _____
 Architect: _____
 Engineer: _____
 Contractor: _____

SUBMITTAL SHEET

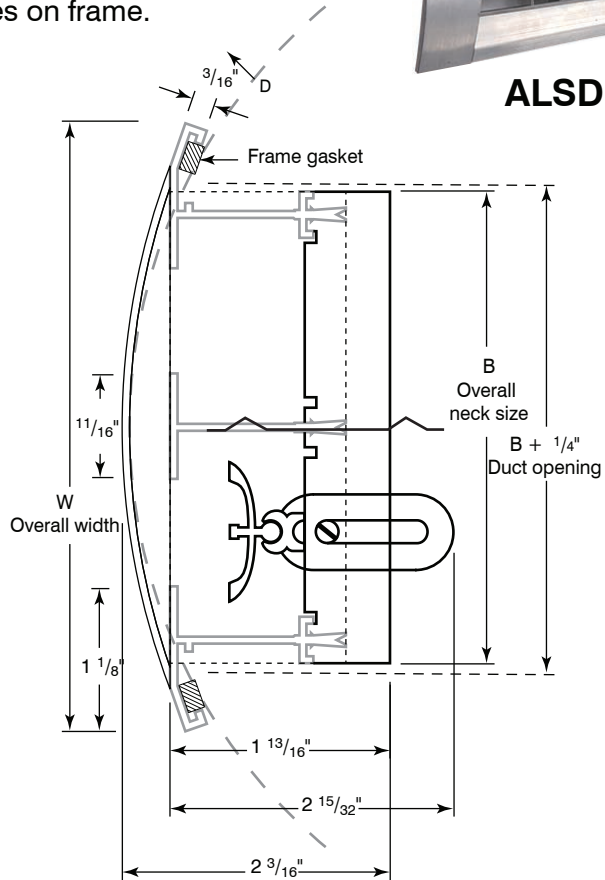
Linear 3/4" Slot Diffuser for Round Ducts

- Material:** Extruded aluminum construction.
Mounting: Surface for round ducts.
Finish: Powder paint coating - white.
Fastening Method: Countersunk mounting holes on frame.



ALSD

- ALSD30**
without pattern-control damper
- ALSD37**
with pattern-control damper
- ALSD38**
with air scoop



✓	NO. OF SLOTS	B	W
	01	1 13/16"	1 1/16"
	02	3 1/4"	3 1/2"
	03	4 11/16"	4 15/16"
	04	6 1/8"	6 3/8"

✓	Duct D	Duct cut out opening			
		1 slot	2 slots	3 slots	4 slots
	10	1 13/16"	3 5/8"		
	12	1 13/16"	3 5/8"		
	14	1 13/16"	3 5/8"	4 15/16"	
	16	1 13/16"	3 1/4"	4 13/8"	7 7/8"
	18	1 13/16"	3 1/4"	4 13/8"	7 7/8"
	20	1 13/16"	3 1/4"	4 13/8"	6 3/4"
	24	1 13/16"	3 1/4"	4 13/8"	6 5/8"
	30	1 13/16"	3 1/4"	4 11/16"	6 5/8"
	40&over	1 13/16"	3 1/4"	4 11/16"	6 5/8"

Finish	
<input type="checkbox"/> /W White (Default)	<input type="checkbox"/> /C Custom (Please Specify)



Schedule type: _____

Job: _____

Architect: _____

Engineer: _____

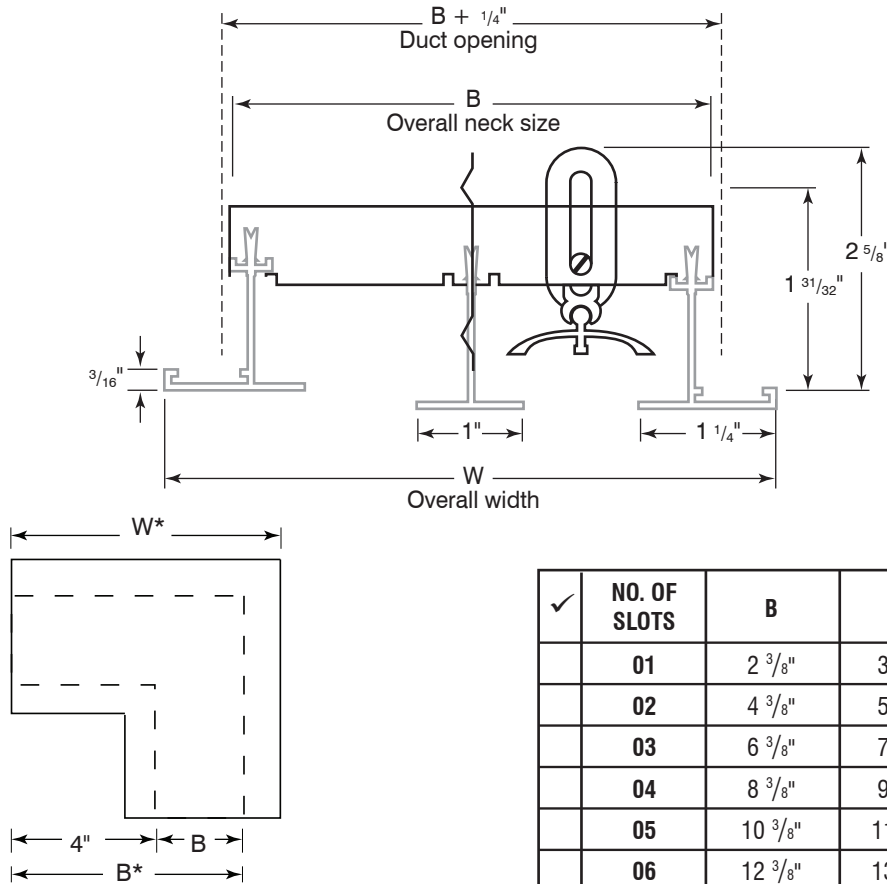
Contractor: _____

Linear 1" Slot Diffuser - Mitered Corner

Material: Extruded aluminum construction.
Mounting: Surface or Lay-in T-bar ceiling.


ALSMC1

SUBMITTAL SHEET



✓	NO. OF SLOTS	B	W	B*	W*
	01	2 3/8"	3 17/32"	6 3/8"	6 15/16"
	02	4 3/8"	5 17/32"	8 3/8"	8 15/16"
	03	6 3/8"	7 17/32"	10 3/8"	10 15/16"
	04	8 3/8"	9 17/32"	12 3/8"	12 15/16"
	05	10 3/8"	11 17/32"	14 3/8"	14 15/16"
	06	12 3/8"	13 17/32"	16 3/8"	16 15/16"
	07	14 3/8"	15 17/32"	18 3/8"	18 15/16"
	08	16 3/8"	17 17/32"	20 3/8"	20 15/16"

 -GK Frame Gasket

Mounting	
<input type="checkbox"/> -E Surface mounting	<input type="checkbox"/> -T T-bar mounting (N/A with -3)

Fastening Method		
<input type="checkbox"/> -1 No Fastening 	<input type="checkbox"/> -3 Screw N/A with -T	<input type="checkbox"/> -4 Concealed

Finish	
<input type="checkbox"/> /W White (Default)	<input type="checkbox"/> /C Custom (Please Specify) _____



Schedule type: _____

Job: _____

Architect: _____

Engineer: _____

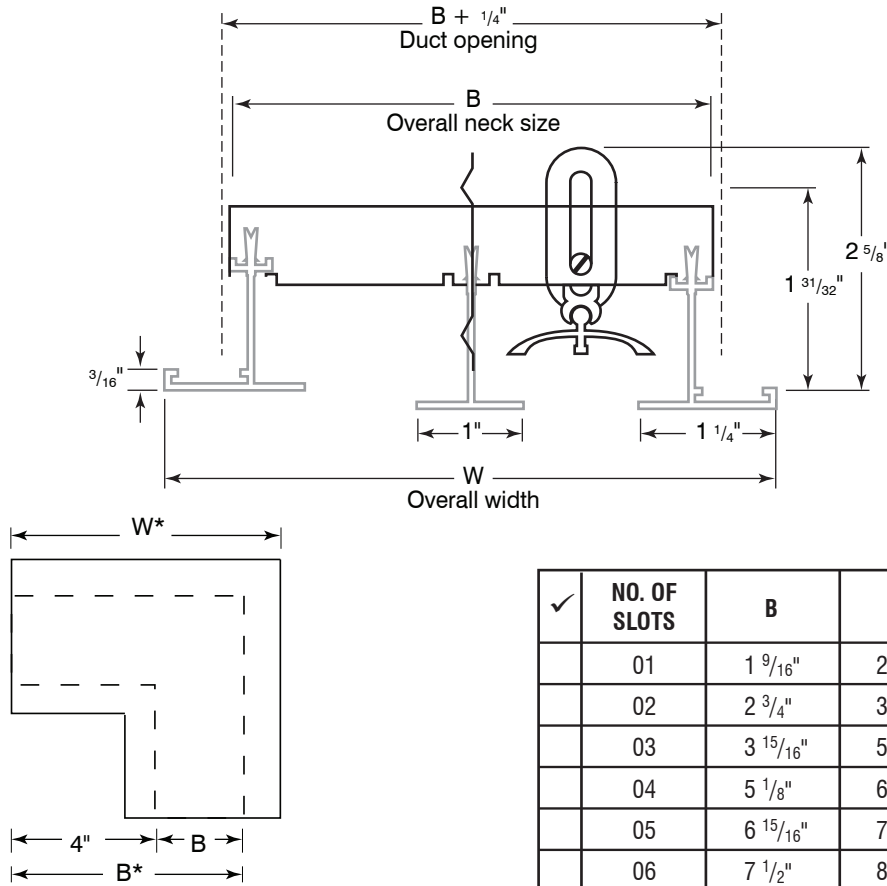
Contractor: _____

Linear 1/2" Slot Diffuser - Mitered Corner

Material: Extruded aluminum construction.
Mounting: Surface or Lay-in T-bar ceiling.



ALSMC2



✓	NO. OF SLOTS	B	W	B*	W*
	01	1 9/16"	2 11/16"	5 9/16"	6 1/8"
	02	2 3/4"	3 15/16"	6 3/4"	7 5/16"
	03	3 15/16"	5 1/8"	7 15/16"	8 9/16"
	04	5 1/8"	6 9/32"	9 1/8"	9 11/16"
	05	6 15/16"	7 15/16"	10 15/16"	11 9/16"
	06	7 1/2"	8 11/16"	11 1/2"	12 1/16"
	07	8 11/16"	9 7/8"	12 11/16"	13 7/16"
	08	9 7/8"	11 1/16"	13 7/8"	14 5/8"

-GK Frame Gasket

Mounting	
<input type="checkbox"/> -E Surface mounting	<input type="checkbox"/> -T T-bar mounting (N/A with -3)

Fastening Method		
<input type="checkbox"/> -1 No Fastening 	<input type="checkbox"/> -3 Screw N/A with -T 	<input type="checkbox"/> -4 Concealed

Finish	
<input type="checkbox"/> /W White (Default)	<input type="checkbox"/> /C Custom (Please Specify) _____

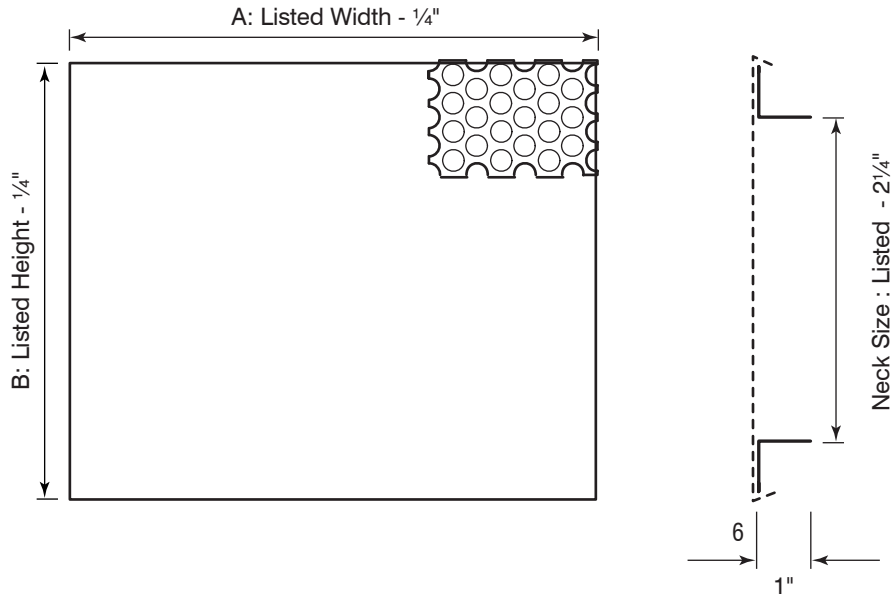


Schedule type: _____
 Job: _____
 Architect: _____
 Engineer: _____
 Contractor: _____

Aluminum Ceiling Return Air Diffuser

- Material:** High capacity all aluminum construction. Full face perforated panel with 3/16" holes on 1/4" staggered centres and 51% open area.
- Finish:** Powder paint white finish.
- Mounting:** For surface mounting or T-bar lay-in ceiling grids.

SUBMITTAL SHEET



✓	Model #	Face Dim. A x B
	APRT 1212	11 ³ / ₄ " x 11 ³ / ₄ "
	APRT 2412	23 ³ / ₄ " x 11 ³ / ₄ "
	APRT 2424	23 ³ / ₄ " x 23 ³ / ₄ "

Finish		
<input type="checkbox"/> /W White (Default)	<input type="checkbox"/> /M Mill Finish	<input type="checkbox"/> /C Custom (Please Specify)

Schedule type: _____
Job: _____
Architect: _____
Engineer: _____
Contractor: _____

SUBMITTAL SHEET

Perforated Face Supply Diffuser Fixed Face - Baffle Deflector

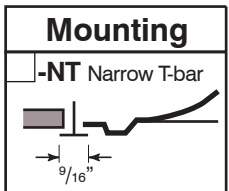
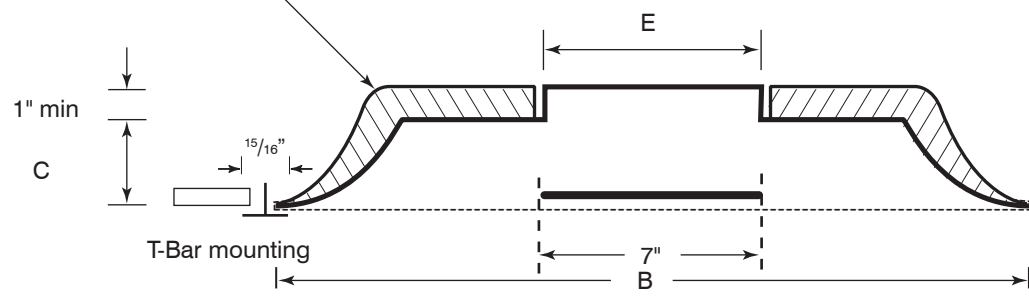
- Material:** Stamped heavy gauge steel back panel.
Aluminum perforated face with 3/16" diam. round holes on 1/4" staggered centers, affords 53% free area.
- Finish:** Powder paint coating - white.
- Air pattern:** Fixed horizontal 360° diffusion.
- Safety:** Seismic tabs.
- Mounting:** Lay-in T-bar ceiling.



APSM
(Aluminum)

Optional fiberglass insulation on back panel, complies with A.S.T.M. E84 flame and smoke test. (Available only on models with 24" x 24" face)

-R4 -R6



Finish

/W White (Default) /C Custom (Please Specify)



✓	Model #	Duct Size	E	Face Dim B x B	C
	APSM 2406	6	5 7/8"	23 7/8" x 23 7/8"	2 7/8"
	APSM 2408	8	7 7/8"	23 7/8" x 23 7/8"	2 7/8"
	APSM 2410	10	9 7/8"	23 7/8" x 23 7/8"	2 7/8"
	APSM 2412	12	11 7/8"	23 7/8" x 23 7/8"	2 7/8"
	APSM 2414	14	13 7/8"	23 7/8" x 23 7/8"	2 7/8"

Schedule type: _____

Job: _____

Architect: _____

Engineer: _____

Contractor: _____

Perforated Face Supply Diffuser Fixed face - Directional Louvers Deflectors

- Material:** Stamped heavy gauge steel back panel.
Aluminum perforated face with 3/16" diam. round holes on 1/4" staggered centers, affords 53% free area.
- Finish:** Powder paint coating - white.
- Air pattern:** Fixed horizontal 360° diffusion.
- Safety:** Seismic tabs.
- Mounting:** Lay-in T-bar ceiling.

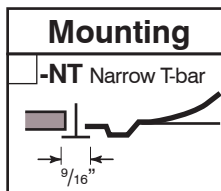
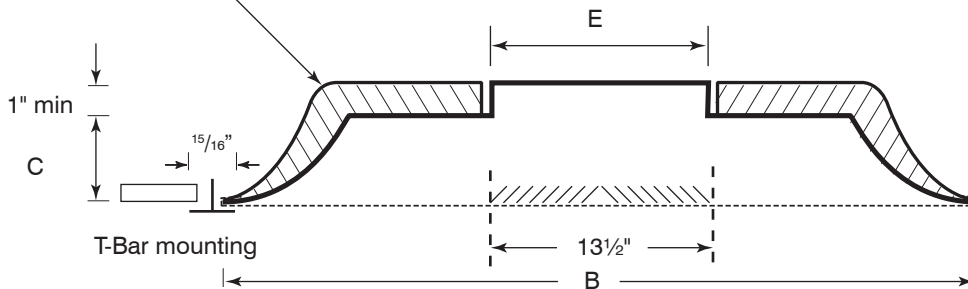


APSMML
(Aluminum)

SUBMITTAL SHEET

Optional fiberglass insulation on back panel, complies with A.S.T.M. E84 flame and smoke test. (Available only on models with 24" x 24" face)

-R4 -R6



Finish	
<input type="checkbox"/> /W White (Default)	<input type="checkbox"/> /C Custom (Please Specify)



✓	Model #	Duct Size	E	Face Dim B x B	C
	APSMML 2406	6	5 7/8"	23 7/8" x 23 7/8"	2 7/8"
	APSMML 2408	8	7 7/8"	23 7/8" x 23 7/8"	2 7/8"
	APSMML 2410	10	9 7/8"	23 7/8" x 23 7/8"	2 7/8"
	APSMML 2412	12	11 7/8"	23 7/8" x 23 7/8"	2 7/8"
	APSMML 2414	14	13 7/8"	23 7/8" x 23 7/8"	2 7/8"

Schedule type: _____

Job: _____

Architect: _____

Engineer: _____

Contractor: _____

Architectural Sidewall Linear Bar Grille

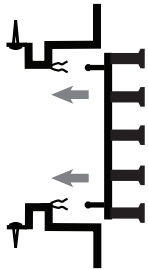
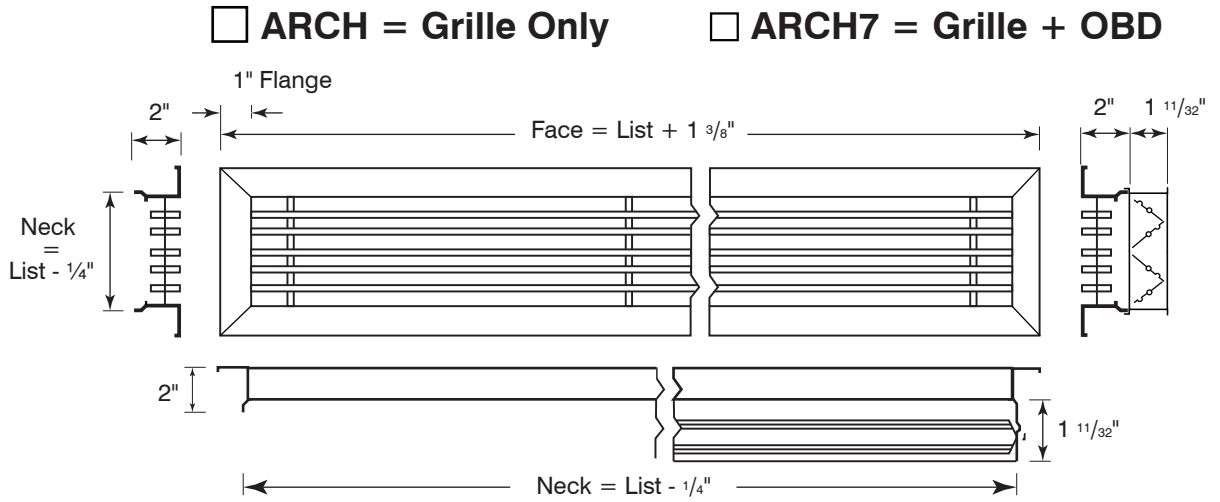
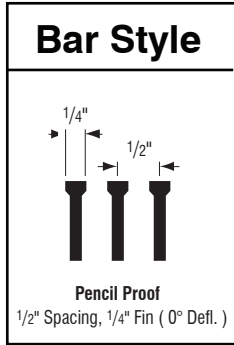
Material: Extruded aluminum
Lengths over 72 inches supplied as multiple sections

Opposed Blade Damper (optional):
Key-operated through grille face or by removing core

Other Styles Available:
Order using ALB model and switch options.
Equivalent ARCH = ALB60-F-5-RM
Equivalent ARCH7 = ALB67-F-5-RM



ARCH / ARCH7



Concealed Screw Holes
Removable Core with Spring Clips



Finish					
<input type="checkbox"/> /W Powder Coated White	<input type="checkbox"/> /M Mill Finish	<input type="checkbox"/> /SI Silver Aluminum Powder Coat	<input type="checkbox"/> /B Brushed Aluminum	<input type="checkbox"/> /L Brushed and Lacquered	<input type="checkbox"/> /Custom Specify here

Options	
<input type="checkbox"/> -CW Security Ceiling Wire	<input type="checkbox"/> -GK Frame Gasket

Schedule type: _____
 Job: _____
 Architect: _____
 Engineer: _____
 Contractor: _____

Dimensions shown contain expansion tolerances based on temperature rise of 40°F above the ambient temperature at which the material is fabricated.

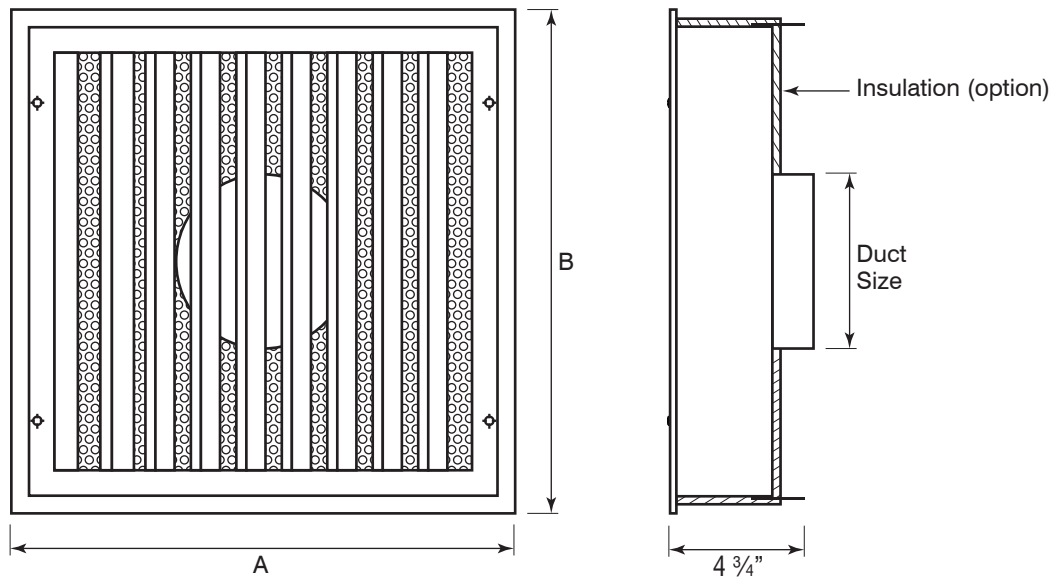
1 Way Radial Air Flow Diffuser Flush Face

- Material:** Aluminum frame.
Finish: Coated steel perforated face with 3/16" diam. round holes on 1/4" staggered centers, affords 53% free area.
Air Pattern: Powder paint coating - white.
Safety: Surface or lay-in T-bar ceiling.
Mounting:



SUBMITTAL SHEET

ARF10
(ARF20 shown here)



✓	Model #	Duct Size	Listed Size	Face Dim A x B
	ARF10 2424	8	24"x24"	23 3/4" x 23 3/4"
	ARF10 2424	10	24"x24"	23 3/4" x 23 3/4"
	ARF10 2448	10	24"x48"	23 3/4" x 47 3/4"
	ARF10 2448	12	24"x48"	23 3/4" x 47 3/4"

Face Option		Mounting	
<input type="checkbox"/> -PFB (default) Perforated face in the back 	<input type="checkbox"/> -PFF Perforated face in the front 	<input type="checkbox"/> -E Surface Mounting 	<input type="checkbox"/> -T T-Bar mounting

Finish	
<input type="checkbox"/> /W White (Default)	<input type="checkbox"/> /C Custom (Please Specify)



Insulation (Option)	Damper (Option)	
<input type="checkbox"/> -R6 fiberglass back 	Refer to N4 Opposed Blade	Refer to N5 Sliding Blade

Schedule type: _____

Job: _____

Architect: _____

Engineer: _____

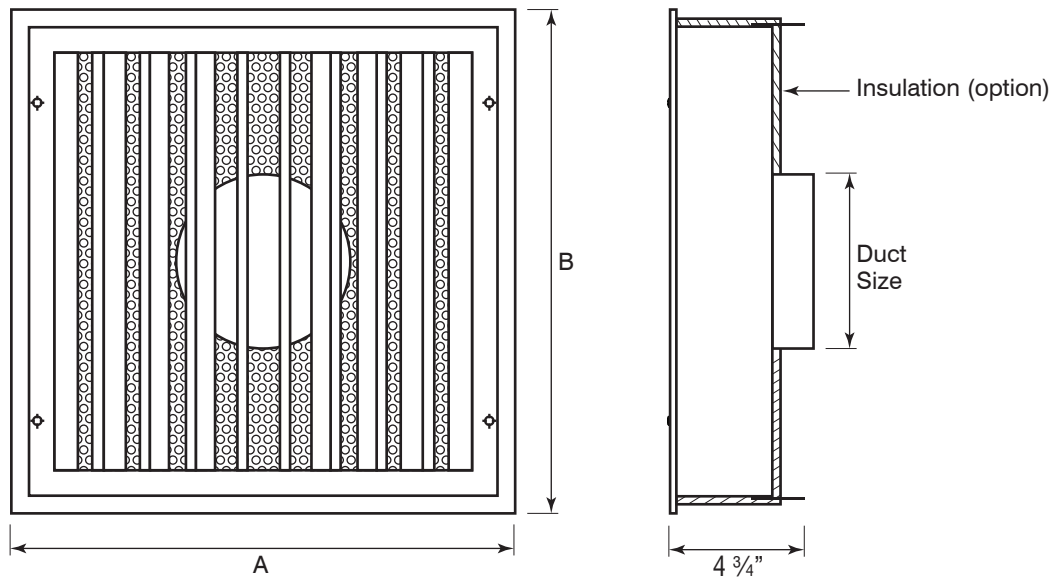
Contractor: _____

2 Way Radial Air Flow Diffuser Flush Face



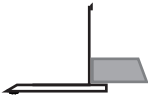

- Material:** Aluminum frame.
- Finish:** Coated steel perforated face with 3/16" diam. round holes on 1/4" staggered centers, affords 53% free area.
- Air Pattern:**
- Safety:** Powder paint coating - white.
- Mounting:** Surface or lay-in T-bar ceiling.










ARF20



✓	Model #	Duct Size	Listed Size	Face Dim A x B
	ARF20 2424	8	24"x24"	23 3/4" x 23 3/4"
	ARF20 2424	10	24"x24"	23 3/4" x 23 3/4"
	ARF20 2448	10	24"x48"	23 3/4" x 47 3/4"
	ARF20 2448	12	24"x48"	23 3/4" x 47 3/4"

Face Option		Mounting	
<input type="checkbox"/> -PFB (default) Perforated face in the back 	<input type="checkbox"/> -PFF Perforated face in the front 	<input type="checkbox"/> -E Surface Mounting 	<input type="checkbox"/> -T T-Bar mounting 

Insulation (Option)	Damper (Option)		
<input type="checkbox"/> -R6 fiberglass back 	<table style="width: 100%;"> <tr> <td style="width: 50%;"> Refer to N4  Opposed Blade </td> <td style="width: 50%;"> Refer to N5  Sliding Blade </td> </tr> </table>	Refer to N4  Opposed Blade	Refer to N5  Sliding Blade
Refer to N4  Opposed Blade	Refer to N5  Sliding Blade		

Finish	
<input type="checkbox"/> /W White (Default)	<input type="checkbox"/> /C Custom (Please Specify) _____



Schedule type: _____

Job: _____

Architect: _____

Engineer: _____

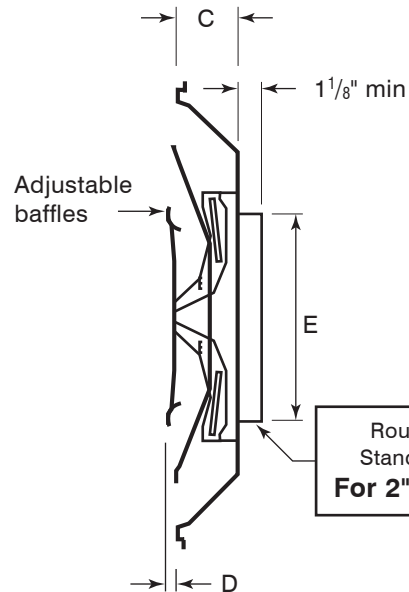
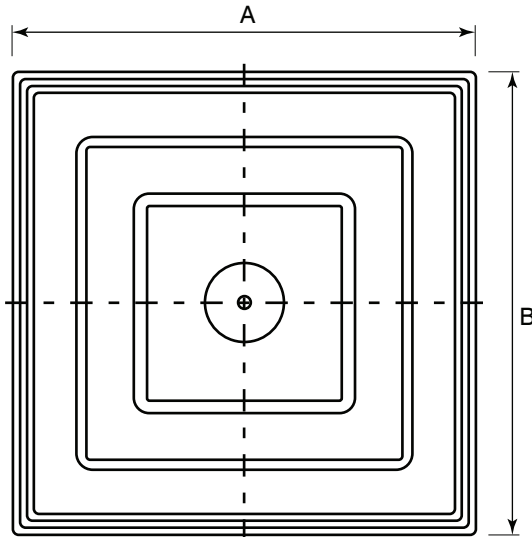
Contractor: _____

Ceiling Supply Air Diffuser 3 Cone Adjustable

- Material:** Stamped heavy gauge steel.
Finish: Powder paint coating - white.
Air Pattern: Adjustable air pattern from horizontal for cooling to vertical for heating, full face.
Safety: Seismic tabs.
Mounting: Surface or lay-in T-bar ceiling.
Core Removal: Unlock hanger brackets by swiveling lever down. Holding cone L at opposite sides, push upwards, then turn clockwise and drop core free from back plenum.


DA3

SUBMITTAL SHEET



Optional fiberglass insulation on back panel, complies with A.S.T.M. E84 flame and smoke test. (Available only on models with 24" x 24" face)



✓	Model #	Duct Size	Overall Face Dimension "A" x "B"	Depth Of Unit Dimension "C"	Exposed Depth Dimension "D"	Collar Diameter "E"
	DA3 1206	6	11 3/4" x 11 3/4"	1 3/4"	7/16"	5 7/8"
	DA3 1208	8	11 3/4" x 11 3/4"	1 3/4"	7/16"	7 7/8"
	DA3 2406	6	23 3/4" x 23 3/4"	2 7/8"	7/8"	5 7/8"
	DA3 2408	8	23 3/4" x 23 3/4"	2 7/8"	7/8"	7 7/8"
	DA3 2410	10	23 3/4" x 23 3/4"	2 7/8"	7/8"	9 7/8"
	DA3 2412	12	23 3/4" x 23 3/4"	2 7/8"	7/8"	11 7/8"
	DA3 2414	14	23 3/4" x 23 3/4"	2 7/8"	7/8"	13 7/8"

Finish	
<input type="checkbox"/> /W White (Default)	<input type="checkbox"/> /C Custom (Please Specify)



Schedule type: _____

Job: _____

Architect: _____

Engineer: _____

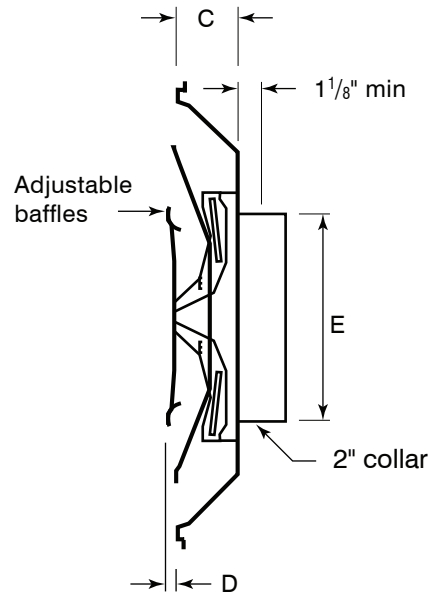
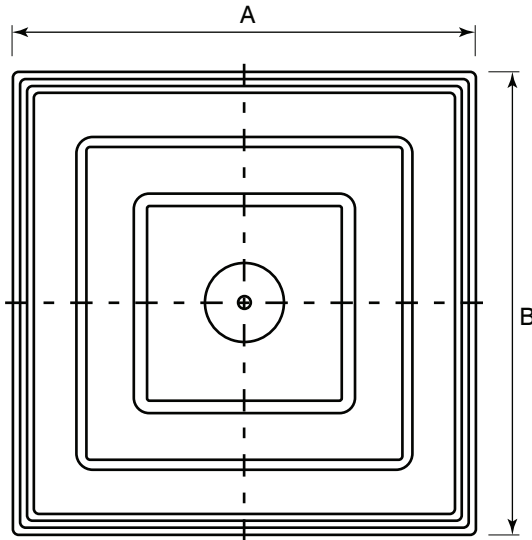
Contractor: _____

Ceiling Supply Air Diffuser 3 Cone Adjustable - 2" High Collar

- Material:** Stamped heavy gauge aluminum.
- Finish:** Powder paint coating - white.
- Air Pattern:** Adjustable air pattern from horizontal for cooling to vertical for heating, full face.
- Safety:** Seismic tabs.
- Mounting:** Surface or lay-in T-bar ceiling.
- Core Removal:** Unlock hanger brackets by swiveling lever down. Holding cone L at opposite sides, push upwards, then turn clockwise and drop core free from back plenum.



DA3D
All Aluminum



Optional fiberglass insulation on back panel, complies with A.S.T.M. E84 flame and smoke test. (Available only on models with 24" x 24" face)

-R4 -R6

✓	Model #	Duct Size	Overall Face Dimension "A" x "B"	Depth Of Unit Dimension "C"	Exposed Depth Dimension "D"	Collar Diameter "E"
	DA3D 1206	6	11 3/4" x 11 3/4"	1 3/4"	7/16"	5 7/8"
	DA3D 1208	8	11 3/4" x 11 3/4"	1 3/4"	7/16"	7 7/8"
	DA3D 2406	6	23 3/4" x 23 3/4"	2 7/8"	7/8"	5 7/8"
	DA3D 2408	8	23 3/4" x 23 3/4"	2 7/8"	7/8"	7 7/8"
	DA3D 2410	10	23 3/4" x 23 3/4"	2 7/8"	7/8"	9 7/8"
	DA3D 2412	12	23 3/4" x 23 3/4"	2 7/8"	7/8"	11 7/8"
	DA3D 2414	14	23 3/4" x 23 3/4"	2 7/8"	7/8"	13 7/8"

Finish	
<input type="checkbox"/> /W White (Default)	<input type="checkbox"/> /C Custom (Please Specify)



Schedule type: _____

Job: _____

Architect: _____

Engineer: _____

Contractor: _____

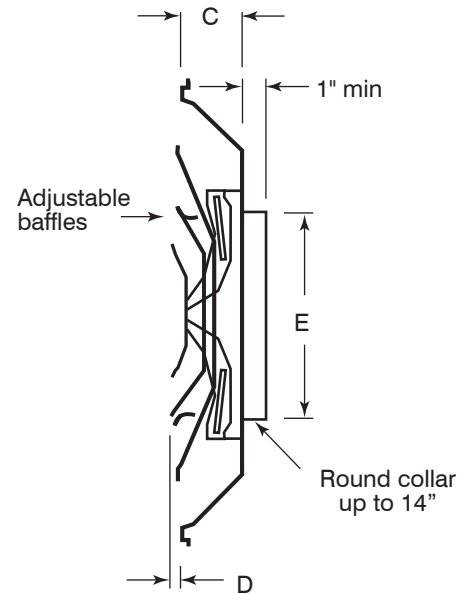
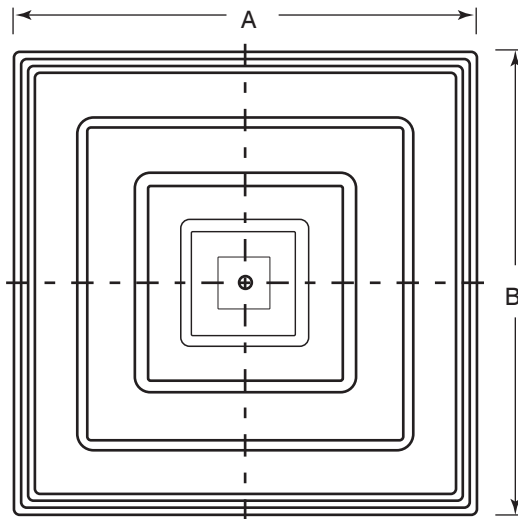
Ceiling Supply Air Diffuser 4 Cone Adjustable

- Material:** Stamped heavy gauge steel.
Finish: Powder paint coating - white.
Air Pattern: Adjustable air pattern from horizontal for cooling to vertical for heating, full face.
Safety: Seismic tabs.
Mounting: Surface or lay-in T-bar ceiling.
Core Removal: Unlock hanger brackets by swiveling lever down. Holding cone L at opposite sides, push upwards, then turn clockwise and drop core free from back plenum.



DA4

SUBMITTAL SHEET



Optional fiberglass insulation on back panel, complies with A.S.T.M. E84 flame and smoke test. (Available only on models with 24" x 24" face)

-R4 -R6



✓	Model #	Duct Size	Overall Face Dimension "A" x "B"	Depth Of Unit Dimension "C"	Exposed Depth Dimension "D"	Collar Diameter "E"
	ADA4 1206	6	11 3/4" x 11 3/4"	1 3/4"	7/16"	5 7/8"
	ADA4 1208	8	11 3/4" x 11 3/4"	1 3/4"	7/16"	7 7/8"
	ADA4 2406	6	23 3/4" x 23 3/4"	2 7/8"	7/8"	5 7/8"
	ADA4 2408	8	23 3/4" x 23 3/4"	2 7/8"	7/8"	7 7/8"
	ADA4 2410	10	23 3/4" x 23 3/4"	2 7/8"	7/8"	9 7/8"
	ADA4 2412	12	23 3/4" x 23 3/4"	2 7/8"	7/8"	11 7/8"
	ADA4 2414	14	23 3/4" x 23 3/4"	2 7/8"	7/8"	13 7/8"

Finish	
<input type="checkbox"/> /W White (Default)	<input type="checkbox"/> /C Custom (Please Specify)

Schedule type: _____

Job: _____

Architect: _____

Engineer: _____

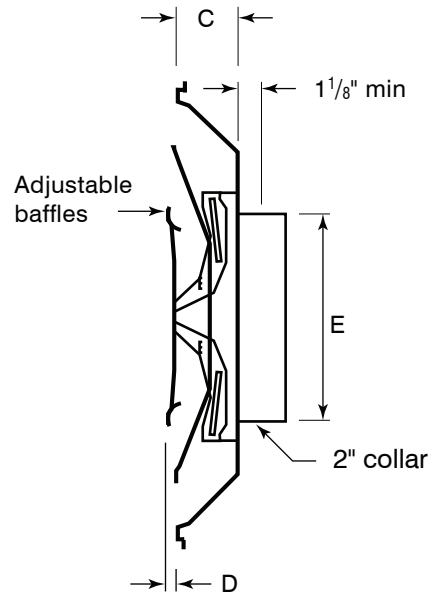
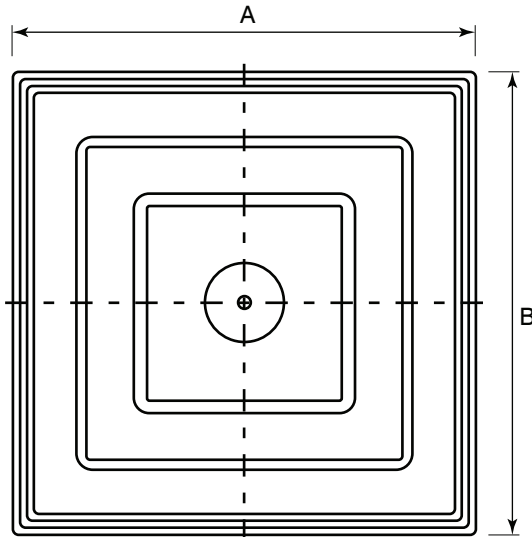
Contractor: _____

Ceiling Supply Air Diffuser 3 Cone Adjustable - 2" High Collar

- Material:** Stamped heavy gauge aluminum.
- Finish:** Powder paint coating - white.
- Air Pattern:** Adjustable air pattern from horizontal for cooling to vertical for heating, full face.
- Safety:** Seismic tabs.
- Mounting:** Surface or lay-in T-bar ceiling.
- Core Removal:** Unlock hanger brackets by swiveling lever down. Holding cone L at opposite sides, push upwards, then turn clockwise and drop core free from back plenum.



DA3D
All Aluminum



Optional fiberglass insulation on back panel, complies with A.S.T.M. E84 flame and smoke test. (Available only on models with 24" x 24" face)

-R4 -R6

✓	Model #	Duct Size	Overall Face Dimension "A" x "B"	Depth Of Unit Dimension "C"	Exposed Depth Dimension "D"	Collar Diameter "E"
	DA3D 1206	6	11 3/4" x 11 3/4"	1 3/4"	7/16"	5 7/8"
	DA3D 1208	8	11 3/4" x 11 3/4"	1 3/4"	7/16"	7 7/8"
	DA3D 2406	6	23 3/4" x 23 3/4"	2 7/8"	7/8"	5 7/8"
	DA3D 2408	8	23 3/4" x 23 3/4"	2 7/8"	7/8"	7 7/8"
	DA3D 2410	10	23 3/4" x 23 3/4"	2 7/8"	7/8"	9 7/8"
	DA3D 2412	12	23 3/4" x 23 3/4"	2 7/8"	7/8"	11 7/8"
	DA3D 2414	14	23 3/4" x 23 3/4"	2 7/8"	7/8"	13 7/8"

Finish	
<input type="checkbox"/> /W White (Default)	<input type="checkbox"/> /C Custom (Please Specify)



Schedule type: _____

Job: _____

Architect: _____

Engineer: _____

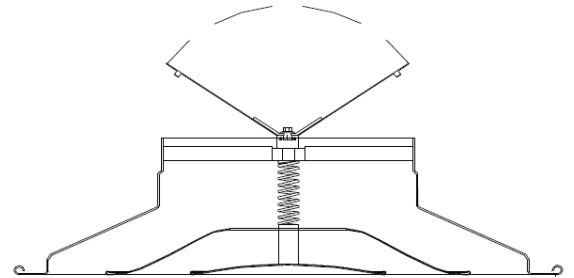
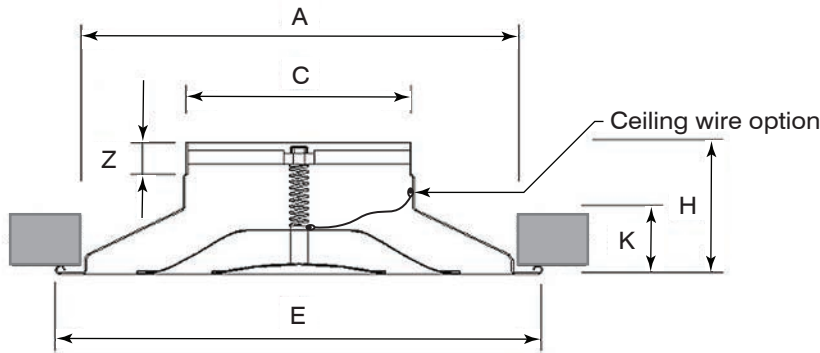
Contractor: _____

High Ceiling Round Diffuser Spun Aluminum Fully Adjustable

- Material:** Heavy gauge spun aluminum.
Finish: Powder paint coating - white.
Air Pattern: 360° diffusion, vertically adjustable.
Mounting: Surface or open ceiling.
Core Adjustment: Rotate the core clockwise or counterclockwise to adjust for horizontal or vertical flow.


DCG

SUBMITTAL SHEET


DCG-R3G

Model	Duct Size	A (in)	C (in)	E (in)	H (in)	K (in)	Z (in)
DCG 06	6"	11 59/64	5 3/4	13 5/16	4 15/16	1 47/64	1
DCG 08	8"	15 5/32	7 3/4	16 47/64	4 17/32	2 9/32	1
DCG 10	10"	18 17/64	9 3/4	19 3/8	4 31/64	2 1/4	1
DCG 12	12"	22 13/64	11 3/4	23 17/64	6 19/32	3 5/32	1
DCG 14	14"	24 13/16	13 29/32	26 1/16	5 33/64	3 17/64	1
DCG 16	16"	24 13/16	15 43/64	26 1/16	5 5/32	2 59/64	1
DCG 18	18"	31 7/32	17 19/32	32 3/4	6 13/16	4 11/64	1
DCG 20	20"	31 7/32	19 9/16	32 3/4	6 27/64	3 13/16	1

Model	Duct Size	A (in)	C (in)	E (in)	H (in)	K (in)	Z (in)
DCG-R3G 08	8"	15 5/32	7 3/4	16 47/64	4 17/32	2 9/32	1
DCG-R3G 10	10"	18 17/64	9 3/4	19 3/8	4 31/64	2 1/4	1
DCG-R3G 14	14"	24 13/16	13 29/32	26 1/16	5 33/64	3 17/64	1
DCG-R3G 16	16"	24 13/16	15 43/64	26 1/16	5 5/32	2 59/64	1
DCG-R3G 18	18"	31 7/32	17 19/32	32 3/4	6 13/16	4 11/64	1
DCG-R3G 20	20"	31 7/32	19 9/16	32 3/4	6 27/64	3 13/16	1

DCG 06 and DCG 12 can't be supplied with R3G but are compatible with N4 opposed blade dampers and N5 sliding blade dampers. Dimensions available with R3G are **not** compatible with N4 and N5 dampers.

Option	
<input type="checkbox"/>	-CW Security Ceiling Wire

Finish	
<input type="checkbox"/> /W White (default)	<input type="checkbox"/> Custom (Please Specify) _____



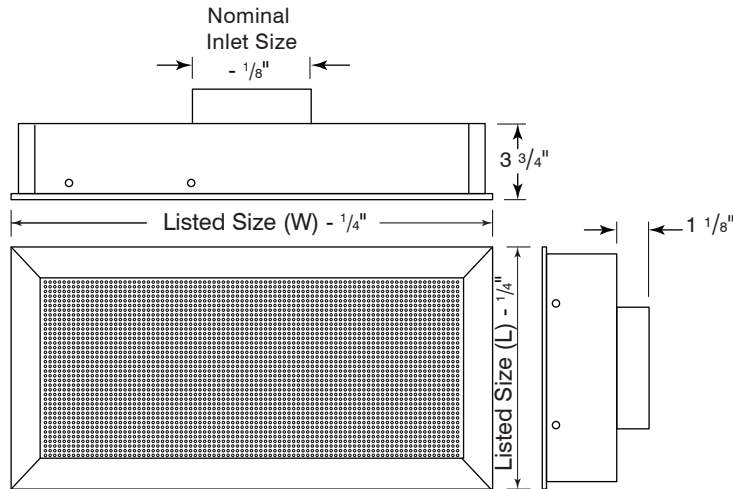
Schedule type: _____
Job: _____
Architect: _____
Engineer: _____
Contractor: _____

Ceiling-Mounted Displacement Diffusers

- Material:** Perforated face steel.
 Aluminum frame and equalization baffle.
 Stamped heavy gauge galvannel steel plenum.
- Finish:** Powder paint coating - white.
- Mounting:** Surface or Lay-in T-bar ceiling.



DDC



✓	Model #	✓ Inlet Size					Face Dim W x H
		6	8	10	12	14	
	DDC 1224						11 3/4" x 23 3/4"
	DDC 2424						23 3/4" x 23 3/4"
	DDC 1248						11 3/4" x 47 3/4"
	DDC 2448						23 3/4" x 47 3/4"
	DDC 2460						23 3/4" x 59 3/4"
	DDC 2472						23 3/4" x 71 3/4"
	DDC <u> </u> x <u> </u> A (Length) B (Width)						W - 1/4" x H - 1/4"

Face Finish				
<input type="checkbox"/> /W	<input type="checkbox"/> /G	<input type="checkbox"/> /BK	<input type="checkbox"/> /B	<input type="checkbox"/> /C Custom (Please Specify)
White (Default)	Grey	Black	Brushed Aluminum	

Schedule type: _____

Job: _____

Architect: _____

Engineer: _____

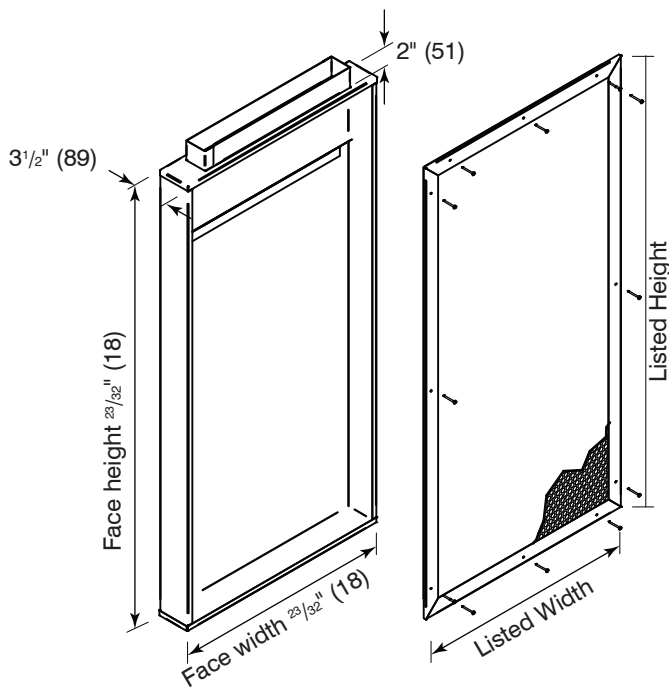
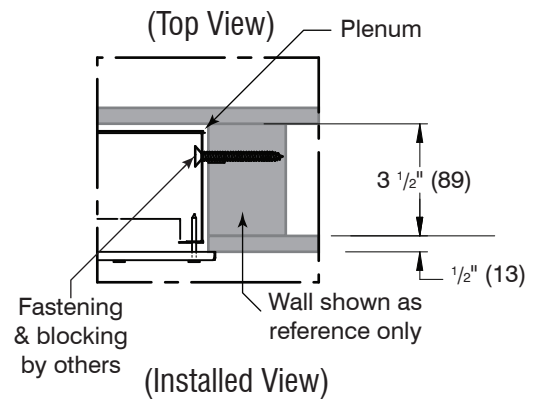
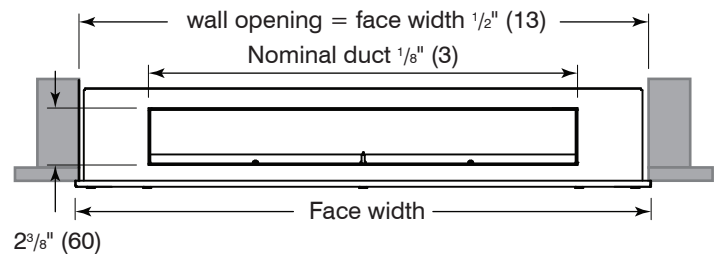
Contractor: _____

Displacement Flow Side-Wall Diffusers

- Material:** Perforated face steel.
 Aluminum frame and equalization baffle.
 Stamped heavy gauge galvannel steel plenum.
- Finish:** Powder paint coating - white.
- Mounting:** Surface Mount.



SUBMITTAL SHEET


DDW


Inlet Size		
-D12 12" x 2 1/2" for face width < 20"	-D18 18" x 2 1/2" for face width ≥ to 20"	-D20 20" x 2 1/2" for face width ≥ to 22"

Face Finish				
/W White (Default)	/G Grey	/BK Black	/B Brushed Aluminum	/C Custom (Please Specify)

Size limits	Width A	
	in	mm
Minimum	15" x 15"	(381 x 381)
Maximum	48" x 24"	(1219 x 610)

Schedule type: _____

Job: _____

Architect: _____

Engineer: _____

Contractor: _____

SUBMITTAL SHEET

Ceiling Square Diffuser - 3 Cone Fixed air pattern

- Material:** Stamped heavy gauge steel.
- Finish:** Powder paint coating - white.
- Air Pattern:** Fixed horizontal 360° diffusion.
- Safety:** Seismic tabs.
- Mounting:** Surface or Lay-in T-bar ceiling.
- Core Removal:** Unlock hanger brackets by swiveling lever down. Holding cone L at opposite sides, push upwards, then turn clockwise and drop core free from back plenum.

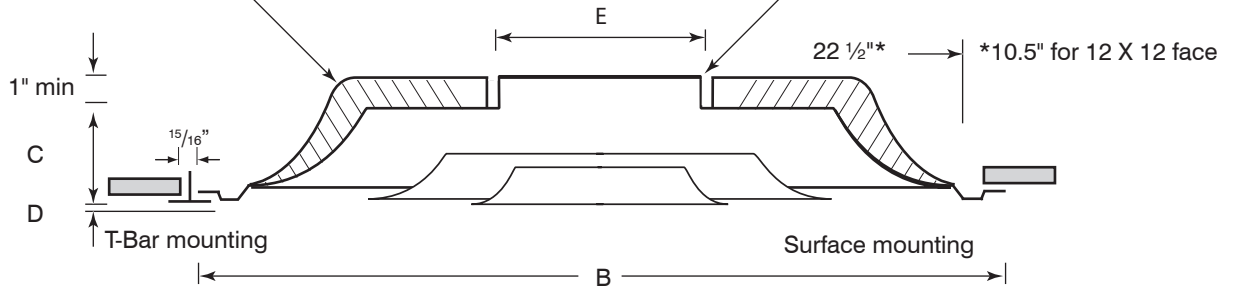


DF3

Optional fiberglass insulation on back panel, complies with A.S.T.M. E84 flame and smoke test. (Available only on models with 24" x 24" face)

- R4 -R6

Round collar up to 14".
Standard height is 1 1/8".
For 2" collar, see DF3D



Mounting (Opt)

-NT Narrow T-bar

Round Collar Baffles

<input type="checkbox"/> W1 1 Way	<input type="checkbox"/> WC 2 Way Corner	<input type="checkbox"/> WO 2 Way Opposed	<input type="checkbox"/> W3 3 Way	<input type="checkbox"/> W4 4 Way (default)

Panel Option for T-bar lay-in Ceiling

	Steel (WxH)	Aluminum (WxH)
<input type="checkbox"/>	-X2412	-Y2412
<input type="checkbox"/>	-X2424	-Y2424
<input type="checkbox"/>	-X2448	-Y2448
<input type="checkbox"/>	-X4824	-Y4824
<input type="checkbox"/>	-X2020	-Y2020

No fastening options available

✓	Model #	Duct Size	E	Face Dim B x B	C	D
	DF3 1206	6	5 7/8"	11 3/4" x 11 3/4"	1 3/4"	7/16"
	DF3 1208	8	7 7/8"	11 3/4" x 11 3/4"	1 3/4"	7/16"
	DF3 2406	6	5 7/8"	23 3/4" x 23 3/4"	2 7/8"	7/8"
	DF3 2408	8	7 7/8"	23 3/4" x 23 3/4"	2 7/8"	7/8"
	DF3 2410	10	9 7/8"	23 3/4" x 23 3/4"	2 7/8"	7/8"
	DF3 2412	12	11 7/8"	23 3/4" x 23 3/4"	2 7/8"	7/8"
	DF3 2414	14	13 7/8"	23 3/4" x 23 3/4"	2 7/8"	7/8"

Finish

/W White (Default) Custom (Please Specify)



<p>Equalizing Grid (Option)</p> <p>Refer to NEG</p>	<p>Damper (Option)</p> <p>Refer to N4 Refer to N5</p> <p>Opposed Blade Sliding Blade</p>		<p>Plaster Frame (Option)</p> <p>Refer to PF</p>

Schedule type: _____

Job: _____

Architect: _____

Engineer: _____

Contractor: _____

Ceiling Square Diffuser 3 Cone - Fixed air pattern - 2" High Collar

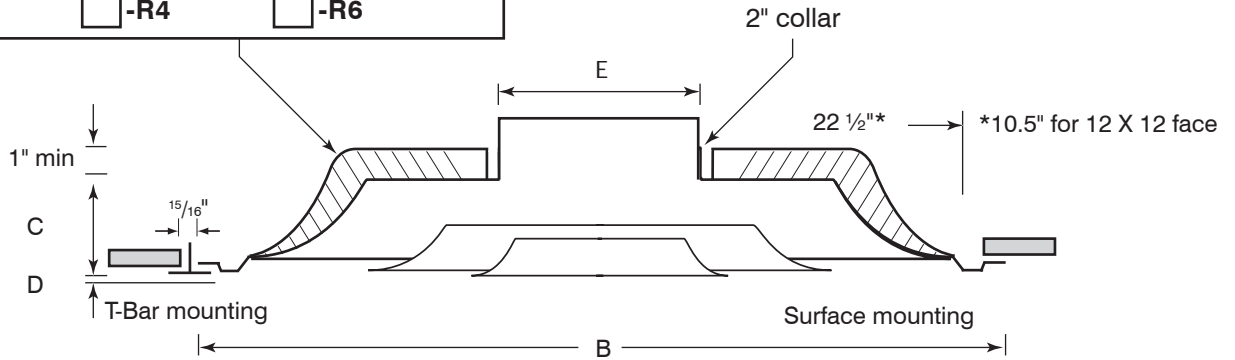
- Material:** Stamped heavy gauge steel.
Finish: Powder paint coating - white.
Air Pattern: Fixed horizontal 360° diffusion.
Safety: Seismic tabs.
Mounting: Surface or Lay-in T-bar ceiling.
 Unlock hanger brackets by swiveling lever down. Holding cone L at opposite sides, push upwards, then turn clockwise and drop core free from back plenum.


DF3D

SUBMITTAL SHEET

Optional fiberglass insulation on back panel, complies with A.S.T.M. E84 flame and smoke test. (Available only on models with 24" x 24" face)

-R4 -R6



Mounting (Opt)

-NT Narrow T-bar

Round Collar Baffles

<input type="checkbox"/> W1 1 Way	<input type="checkbox"/> WC 2 Way Corner	<input type="checkbox"/> WO 2 Way Opposed	<input type="checkbox"/> W3 3 Way	<input type="checkbox"/> W4 4 Way (default)

Panel Option for T-bar lay-in Ceiling

	Steel (WxH)	Aluminum (WxH)
<input type="checkbox"/>	-X2412	-Y2412
<input type="checkbox"/>	-X2424	-Y2424
<input type="checkbox"/>	-X2448	-Y2448
<input type="checkbox"/>	-X4824	-Y4824
<input type="checkbox"/>	-X2020	-Y2020

No fastening options available

✓	Model #	Duct Size	E	Face Dim B x B	C	D
	DF3D 1206	6	5 7/8"	11 3/4" x 11 3/4"	1 3/4"	7/16"
	DF3D 1208	8	7 7/8"	11 3/4" x 11 3/4"	1 3/4"	7/16"
	DF3D 2406	6	5 7/8"	23 3/4" x 23 3/4"	2 5/16"	1 3/8"
	DF3D 2408	8	7 7/8"	23 3/4" x 23 3/4"	2 5/16"	1 3/8"
	DF3D 2410	10	9 7/8"	23 3/4" x 23 3/4"	2 5/16"	1 3/8"
	DF3D 2412	12	11 7/8"	23 3/4" x 23 3/4"	2 5/16"	1 3/8"
	DF3D 2414	14	11 7/8"	23 3/4" x 23 3/4"	2 5/16"	1 3/8"

Finish

/W White (Default) /C Custom (Please Specify)



Equalizing Grid (Option) Refer to NEG 	Damper (Option) Refer to N4 Refer to N5 Opposed Blade Sliding Blade		Plaster Frame (Option) Refer to PF
---	--	--	--

Schedule type: _____

Job: _____

Architect: _____

Engineer: _____

Contractor: _____

Ceiling Square Diffuser 3 Cone - Fixed air pattern

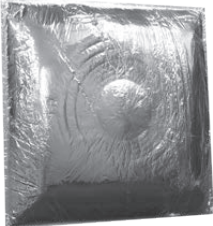
- Material:** Stamped heavy gauge steel.
- Finish:** Powder paint coating - white.
- Air Pattern:** Fixed horizontal 360° diffusion.
- Safety:** Seismic tabs.
- Mounting:** Lay-in T-bar ceiling.
- Core Removal:** Unlock hanger brackets by swiveling lever down. Holding cone L at opposite sides, push upwards, then turn clockwise and drop core free from back plenum.

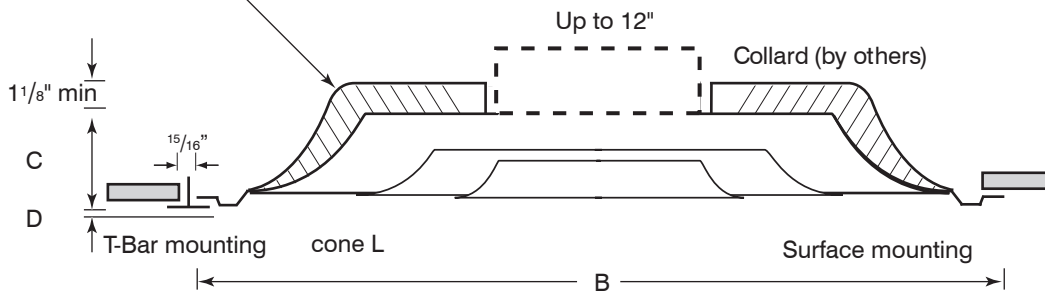


DF3I

NR6MFG fiberglass back complies with A.S.T.M. E84 flame and smoke test.

Scored for collar sizes up to 12" D.
Contractor to install job-specific collar in field. For size 14", please refer to model ADF3-R6 2414.





Model #	Face Dim B x B	C	D
DF3I	23 3/4" x 23 3/4"	2 7/8"	7/8"

Finish	
<input type="checkbox"/> /W	<input type="checkbox"/> /C Custom (Please Specify)
White (Default)	_____



Schedule type: _____

Job: _____

Architect: _____

Engineer: _____

Contractor: _____

Ceiling Square Diffuser - 4 Cone Fixed air pattern

- Material:** Stamped heavy gauge steel.
Finish: Powder paint coating - white.
Air Pattern: Fixed horizontal 360° diffusion.
Safety: Seismic tabs.
Mounting: Surface or Lay-in T-bar ceiling.
 Unlock hanger brackets by swiveling lever down. Holding cone L at opposite sides, push upwards, then turn clockwise and drop core free from back plenum.

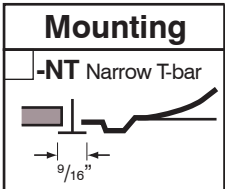
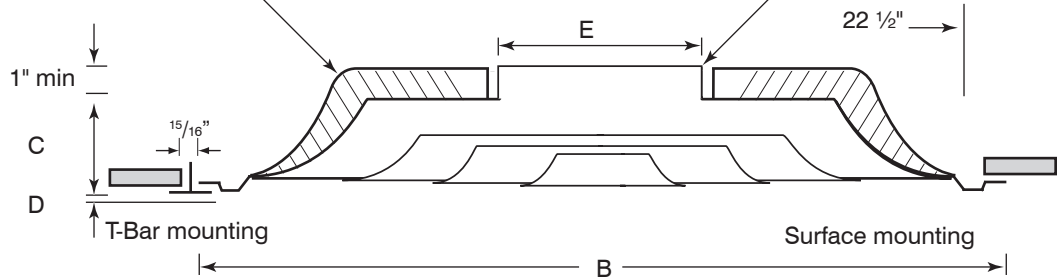

DF4

SUBMITTAL SHEET

Optional fiberglass insulation on back panel, complies with A.S.T.M. E84 flame and smoke test. (Available only on models with 24" x 24" face)

-R4 -R6

Round collar up to 14".
Standard height is 1 1/8".
For 2" collar, see DF4D



Round Collar Baffles

<input type="checkbox"/> W1 1 Way	<input type="checkbox"/> WC 2 Way Corner	<input type="checkbox"/> WO 2 Way Opposed	<input type="checkbox"/> W3 3 Way	<input type="checkbox"/> W4 4 Way (default)

Panel Option for T-bar lay-in Ceiling

	Steel (WxH)	Aluminum (WxH)
	<input type="checkbox"/> -X2412	<input type="checkbox"/> -Y2412
	<input type="checkbox"/> -X2424	<input type="checkbox"/> -Y2424
	<input type="checkbox"/> -X2448	<input type="checkbox"/> -Y2448
	<input type="checkbox"/> -X4824	<input type="checkbox"/> -Y4824
	<input type="checkbox"/> -X2020	<input type="checkbox"/> -Y2020

No fastening options available

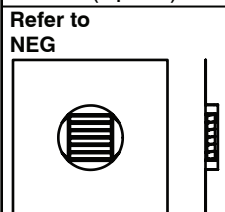
<input checked="" type="checkbox"/>	Model #	Duct Size	E	Face Dim B x B	C	D
	DF4 2406	6	5 7/8"	23 3/4" x 23 3/4"	2 5/16"	1 3/8"
	DF4 2408	8	7 7/8"	23 3/4" x 23 3/4"	2 5/16"	1 3/8"
	DF4 2410	10	9 7/8"	23 3/4" x 23 3/4"	2 5/16"	1 3/8"
	DF4 2412	12	11 7/8"	23 3/4" x 23 3/4"	2 5/16"	1 3/8"
	DF4 2414	14	11 7/8"	23 3/4" x 23 3/4"	2 5/16"	1 3/8"

Finish

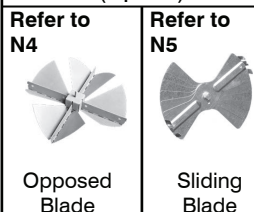
/W White (Default) /C Custom (Please Specify)



Equalizing Grid (Option)



Damper (Option)



Plaster Frame (Option)



Schedule type: _____
 Job: _____
 Architect: _____
 Engineer: _____
 Contractor: _____

SUBMITTAL SHEET

Ceiling Square Diffuser 4 Cone - Fixed air pattern - 2" High Collar

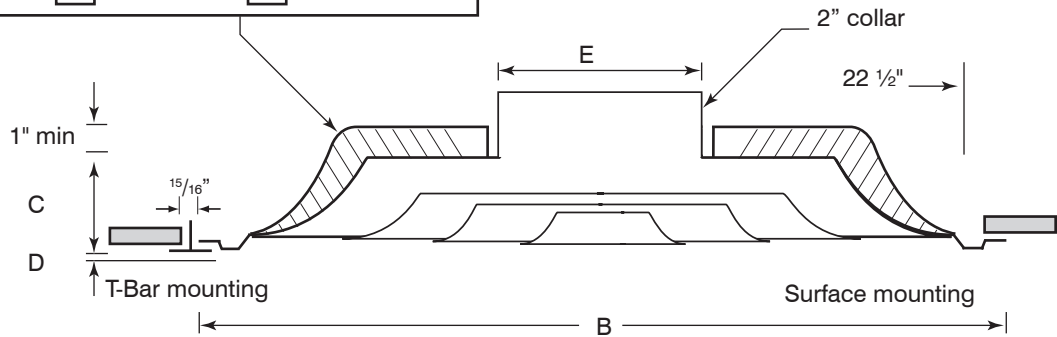
- Material:** Stamped heavy gauge steel.
- Finish:** Powder paint coating - white.
- Air Pattern:** Fixed horizontal 360° diffusion.
- Safety:** Seismic tabs.
- Mounting:** Surface or Lay-in T-bar ceiling.
Unlock hanger brackets by swiveling lever down. Holding cone L at opposite sides, push upwards, then turn clockwise and drop core free from back plenum.



DF4D

Optional fiberglass insulation on back panel, complies with A.S.T.M. E84 flame and smoke test. (Available only on models with 24" x 24" face)

- R4
- R6



Mounting

-NT Narrow T-bar

Round Collar Baffles

<input type="checkbox"/> W1 1 Way	<input type="checkbox"/> WC 2 Way Corner	<input type="checkbox"/> WO 2 Way Opposed	<input type="checkbox"/> W3 3 Way	<input type="checkbox"/> W4 4 Way (default)

Panel Option for T-bar lay-in Ceiling

	Steel (WxH)	Aluminum (WxH)
<input type="checkbox"/>	-X2412	-Y2412
<input type="checkbox"/>	-X2424	-Y2424
<input type="checkbox"/>	-X2448	-Y2448
<input type="checkbox"/>	-X4824	-Y4824
<input type="checkbox"/>	-X2020	-Y2020

No fastening options available

✓	Model #	Duct Size	E	Face Dim B x B	C	D
	DF4D 2406	6	5 7/8"	23 3/4" x 23 3/4"	2 5/16"	1 3/8"
	DF4D 2408	8	7 7/8"	23 3/4" x 23 3/4"	2 5/16"	1 3/8"
	DF4D 2410	10	9 7/8"	23 3/4" x 23 3/4"	2 5/16"	1 3/8"
	DF4D 2412	12	11 7/8"	23 3/4" x 23 3/4"	2 5/16"	1 3/8"
	DF4D 2414	14	11 7/8"	23 3/4" x 23 3/4"	2 5/16"	1 3/8"

Finish

/W White (Default)

/C Custom (Please Specify)



<p>Equalizing Grid (Option)</p> <p>Refer to NEG</p>	<p>Damper (Option)</p> <p>Refer to N4</p> <p>Opposed Blade</p> <p>Refer to N5</p> <p>Sliding Blade</p>	<p>Plaster Frame (Option)</p> <p>Refer to PF</p>
--	---	---

Schedule type: _____

Job: _____

Architect: _____

Engineer: _____

Contractor: _____

Ceiling Square Diffuser 4 Cone - Fixed air pattern

- Material:** Stamped heavy gauge steel.
- Finish:** Powder paint coating - white.
- Air Pattern:** Fixed horizontal 360° diffusion.
- Safety:** Seismic tabs.
- Mounting:** Lay-in T-bar ceiling.
- Core Removal:** Unlock hanger brackets by swiveling lever down. Holding cone L at opposite sides, push upwards, then turn clockwise and drop core free from back plenum.

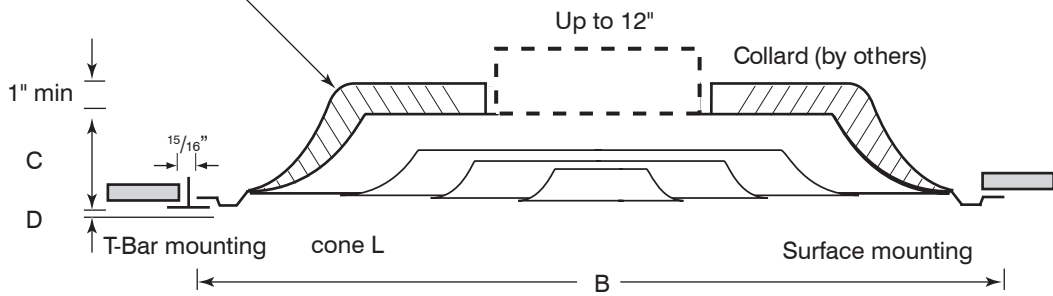


DF4I

SUBMITTAL SHEET

NR6MFG fiberglass back complies with A.S.T.M. E84 flame and smoke test.

Scored for collar sizes up to 12" D. Contractor to install job-specific collar in field. For size 14", please refer to model DF4-R6 2414.



Model #	Face Dim B x B	C	D
DF4I	23 3/4" X 23 3/4"	2 7/8"	7/8"

Finish	
<input type="checkbox"/> /W White (Default)	<input type="checkbox"/> /C Custom (Please Specify)



Schedule type: _____

Job: _____

Architect: _____

Engineer: _____

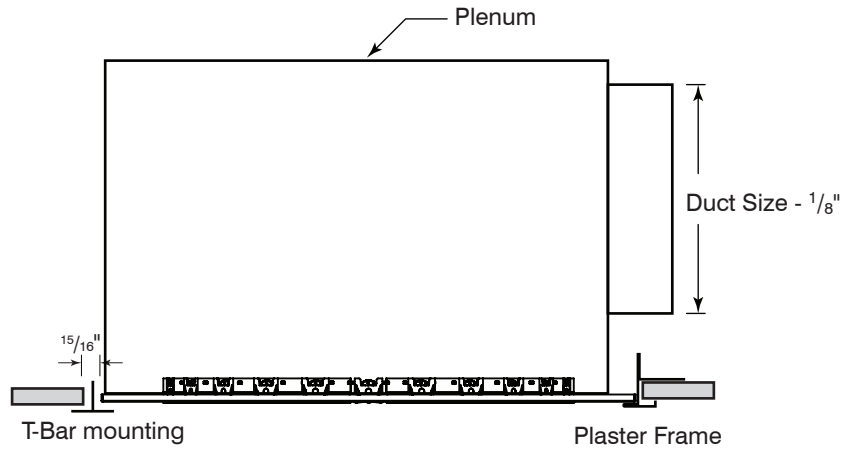
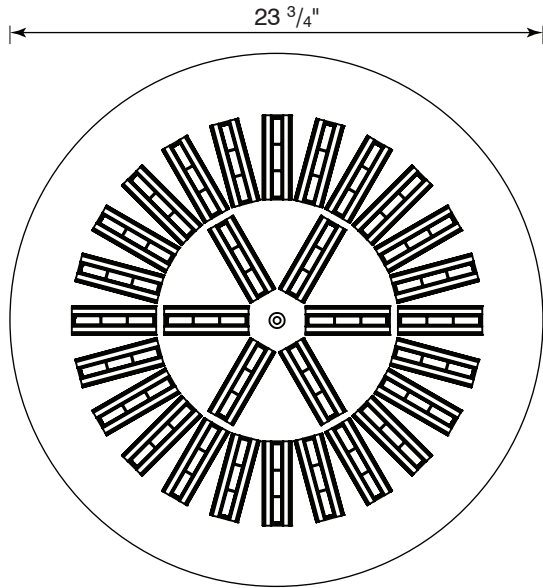
Contractor: _____

Round Nozzle Diffuser

- Material:** Stamped heavy gauge steel,
Fire resistant polypropylene nozzle.
- Finish:** Powder paint coating - white.
- Air Pattern:** Adjustable 360° spiral pattern.
- Mounting:** Lay-in T-bar ceiling or plaster frame.

DHIR No Plenum

DHIR-PL With Plenum



Nozzle Pattern and Quantité		
<input checked="" type="checkbox"/> Radial	<input checked="" type="checkbox"/> Peripheral	<input type="checkbox"/> Twist <i>coming soon</i>
-RA8	-PR8	-TW8
-RA16	-PR16	-TW16
-RA32	-PR32	-TW32
-RA42	-PR42	-TW42
-RA60	-PR60	-TW60

Duct Size		Plenum Inlet Location	
<input checked="" type="checkbox"/> -6	6	<input type="checkbox"/> -TP Top	<input type="checkbox"/> -SD Side
<input type="checkbox"/> -8	8		
<input type="checkbox"/> -10	10		
<input type="checkbox"/> -12	12		
<input type="checkbox"/> -14	14		

Nozzle Color		
<input type="checkbox"/> /W White (Default)	<input type="checkbox"/> /BK Black	<input type="checkbox"/> /C Custom (Please Specify) _____

Finish		
<input type="checkbox"/> /W White (Default)	<input type="checkbox"/> /BK Black	<input type="checkbox"/> /C Custom (Please Specify) _____



Schedule type: _____

Job: _____

Architect: _____

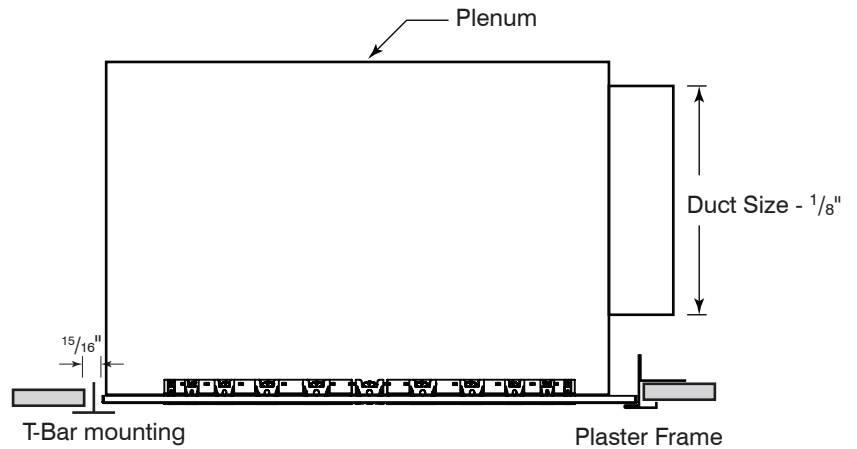
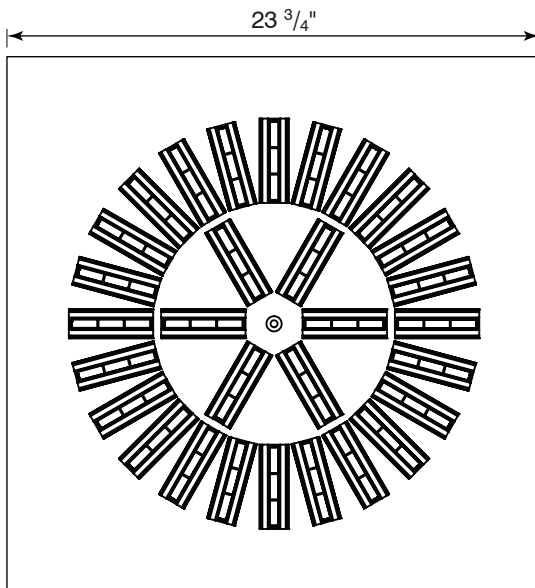
Engineer: _____

Contractor: _____

Square Nozzle Diffuser

- Material:** Stamped heavy gauge steel,
Fire resistant polypropylene nozzle.
- Finish:** Powder paint coating - white.
- Air Pattern:** Adjustable 360° spiral pattern.
- Mounting:** Lay-in T-bar ceiling or plaster frame.


DHIS
 DHIS No Plenum

 DHIS-PL With Plenum


Nozzle Pattern and Quantité		
<input checked="" type="checkbox"/> Radial	<input checked="" type="checkbox"/> Square	<input checked="" type="checkbox"/> Twist
-RA8	-SQ8	-TW8
-RA16	-SQ16	-TW16
-RA32	-SQ32	-TW32
-RA42	-SQ42	-TW42
-RA60	-SQ60	-TW60
<input checked="" type="checkbox"/> Duct Size	Plenum Inlet Location	
-6 6	<input type="checkbox"/> -TP Top	<input type="checkbox"/> -SD Side
-8 8		
-10 10		
-12 12		
-14 14		

Nozzle Color		
<input type="checkbox"/> /W White (Default)	<input type="checkbox"/> /BK Black	<input type="checkbox"/> /C Custom (Please Specify) _____
Finish		
<input type="checkbox"/> /W White (Default)	<input type="checkbox"/> /BK Black	<input type="checkbox"/> /C Custom (Please Specify) _____



Schedule type: _____

Job: _____

Architect: _____

Engineer: _____

Contractor: _____

SUBMITTAL SHEET

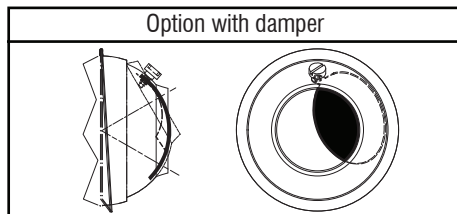
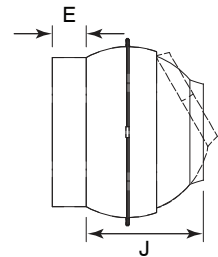
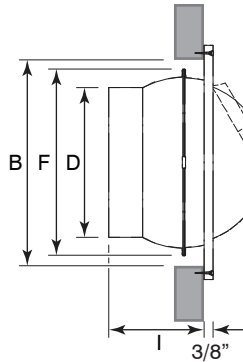
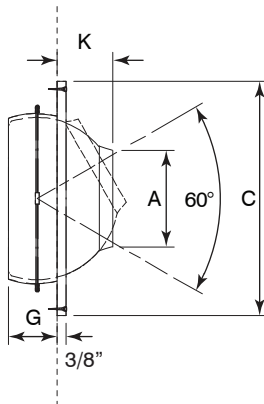
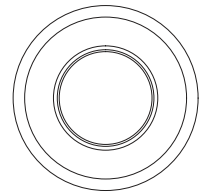
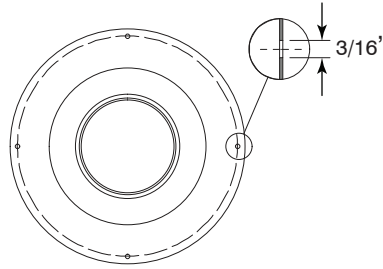
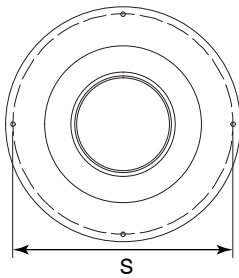
High Ceiling Round Diffuser Spun Aluminum Fully Adjustable Short Pipe

Material: Aluminum.
Finish: Powder paint coating - white.
Adjustment: Jet nozzles, discharge angle 30°



DKS1

- | | | |
|--|--|--|
| <input type="checkbox"/> DKS10 Without damper | <input type="checkbox"/> DKS20 Without damper | <input type="checkbox"/> DKS30 Without damper |
| <input type="checkbox"/> DKS11 With damper | <input type="checkbox"/> DKS21 With damper | <input type="checkbox"/> DKS31 With damper |



Finish	
<input type="checkbox"/> /W White (Default)	<input type="checkbox"/> /C Custom (Please Specify)



✓	Duct Size	A	B	C	D	E	F	G	I	J	K	S
	6	4"	8 5/8"	9 3/4"	5 3/4"	4 7/16"	7 11/16"	2"	4"	4 7/8"	2 5/16"	9 3/16"
	8	5 5/16"	10 3/16"	11 3/4"	7 7/8"	1 1/2"	9 3/4"	2 11/16"	4 9/16"	5 9/16"	2 1/2"	10 5/8"
	10	6 7/8"	12 3/16"	14 5/16"	9 13/16"	1 11/16"	11 5/16"	3 3/16"	5 1/8"	6 3/8"	2 15/16"	12 5/8"
	12	8 1/2"	14 7/8"	17 13/16"	11 3/4"	5"	14"	4"	6 1/8"	7 7/8"	3 1/8"	15 3/8"
	16	15 3/4"	20 1/16"	23 7/8"	15 3/4"	2 3/8"	17 5/16"	17 3/4"	7 7/16"	10 1/8"	5 1/16"	22 7/16"

Schedule type: _____

Job: _____

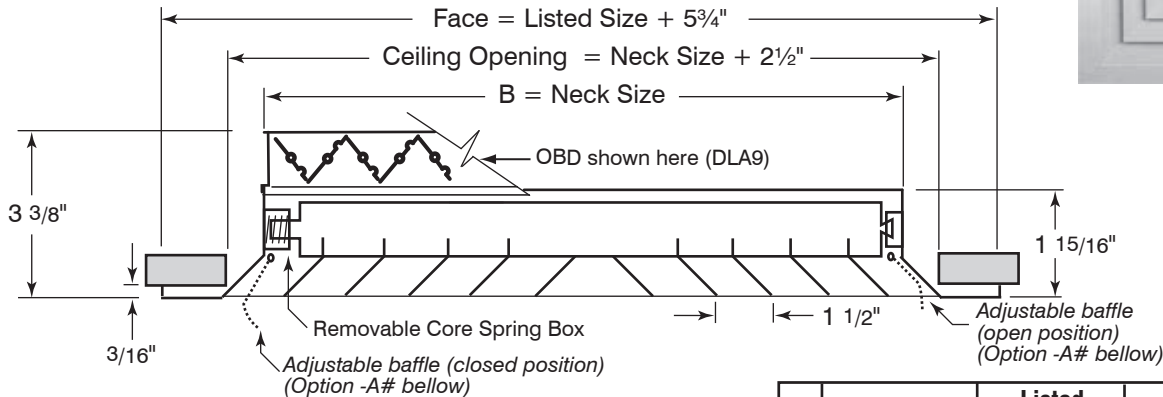
Architect: _____

Engineer: _____

Contractor: _____

Ceiling Diffuser - Aluminum Louvered Face Directional Fixed Air Pattern - Square

- Material:** Heavy gauge aluminum.
Finish: Powder paint coating - white.
Mounting: Surface or Lay-in T-bar ceiling.
Volume Control: Available with pre-installed aluminum OBD (Model# DLA9).


DLA

 -ES Square Equalizing Grid

Border Type

<input type="checkbox"/> -F Flat Frame (Default)	<input type="checkbox"/> -B Beveled Frame

Mounting

<input type="checkbox"/> -NT Narrow T-bar	<input type="checkbox"/> -O Lay-In	<input type="checkbox"/> -1 Screw Holes	<input type="checkbox"/> -4 Concealed

Core Selection (-W) & Adjustable Baffles (-A)

<input type="checkbox"/> -W1 1 Way	<input type="checkbox"/> -WC 2 Way Corner	<input type="checkbox"/> -WO 2 Way Opposed	<input type="checkbox"/> -W3 3 Way	<input type="checkbox"/> -W4 4 Way (Default)
<input type="checkbox"/> -A1 shown here in dotted line	<input type="checkbox"/> -AC shown here in dotted line	<input type="checkbox"/> -AO shown here in dotted line	<input type="checkbox"/> -A3 shown here in dotted line	<input type="checkbox"/> -A4 shown here in dotted line

Panel Option for T-bar lay-in Ceiling

	Steel (WxH)	Aluminum (WxH)
	<input type="checkbox"/> -X2412	<input type="checkbox"/> -Y2412
	<input type="checkbox"/> -X2424	<input type="checkbox"/> -Y2424
	<input type="checkbox"/> -X4812	<input type="checkbox"/> -Y4812
	<input type="checkbox"/> -X4824	<input type="checkbox"/> -Y4824

No mounting options available

<input checked="" type="checkbox"/>	Model #	Listed Size	Neck Size B	Face Size
	DLA 0606	6" x 6"	5 15/16" x 5 15/16"	11 3/4" x 11 3/4"
	DLA 0909	9" x 9"	8 15/16" x 8 15/16"	14 3/4" x 14 3/4"
	DLA 1212	12" x 12"	11 15/16" x 11 15/16"	17 3/4" x 17 3/4"
	DLA 1515	15" x 15"	14 15/16" x 14 15/16"	20 3/4" x 20 3/4"
	DLA 1818	18" x 18"	17 15/16" x 17 15/16"	23 3/4" x 23 3/4"
	DLA9 0606	6" x 6"	6 3/16" x 6 3/16"	11 3/4" x 11 3/4"
	DLA9 0909	9" x 9"	9 3/16" x 9 3/16"	14 3/4" x 14 3/4"
	DLA9 1212	12" x 12"	12 3/16" x 12 3/16"	17 3/4" x 17 3/4"
	DLA9 1515	15" x 15"	14 3/16" x 14 3/16"	20 3/4" x 20 3/4"
	DLA9 1818	18" x 18"	17 3/16" x 17 3/16"	23 3/4" x 23 3/4"

Plaque options Only with -W4

<input type="checkbox"/> -PQ1	<input type="checkbox"/> -PQ2	<input type="checkbox"/> -PQ3	<input type="checkbox"/> -PQ4

Finish

<input type="checkbox"/> /W White (Default)	<input type="checkbox"/> /C Custom (Please Specify)
---	---



Schedule type: _____
 Job: _____
 Architect: _____
 Engineer: _____
 Contractor: _____

SUBMITTAL SHEET

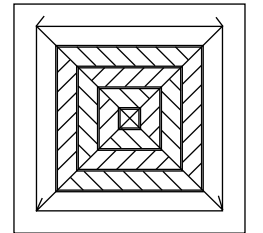
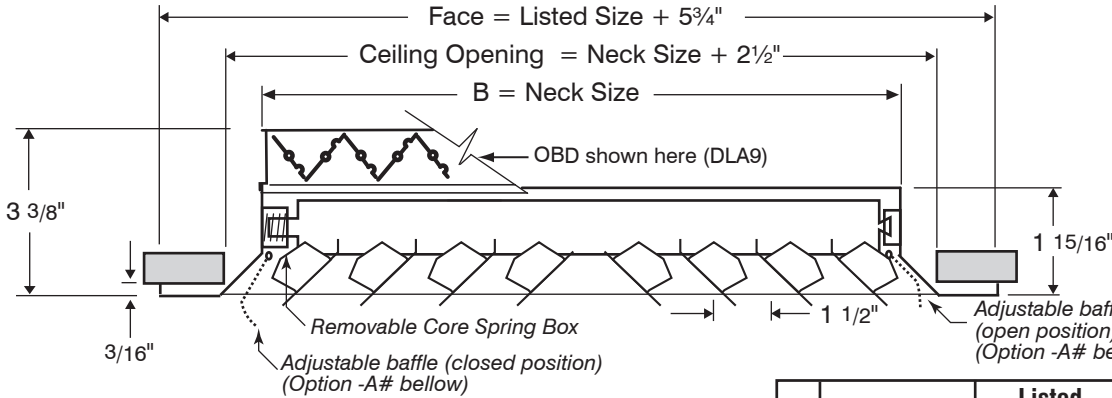
SUBMITTAL SHEET

Ceiling Diffuser - Aluminum Louvered Face Directional Fixed Air Pattern - Square Neck

- Material:** Heavy gauge aluminum.
- Finish:** Powder paint coating - white.
- Mounting:** Surface or Lay-in T-bar ceiling.
- Volume Control:** Available with pre-installed aluminum OBD (Model# DLA9-HI).



DLA-HI



High Induction Vanes

-ES Square Equalizing Grid

Border Type

<input type="checkbox"/> -F Flat Frame	<input type="checkbox"/> -B Beveled Frame
--	---

Mounting

<input type="checkbox"/> -NT Narrow T-bar	<input type="checkbox"/> -0 Lay-In	<input type="checkbox"/> -1 Screw Holes	<input type="checkbox"/> -4 Concealed
---	------------------------------------	---	---------------------------------------

Core Selection (-W) & Adjustable Baffles (-A)

<input type="checkbox"/> -W1 1 Way	<input type="checkbox"/> -WC 2 Way Corner	<input type="checkbox"/> -WO 2 Way Opposed	<input type="checkbox"/> -W3 3 Way	<input type="checkbox"/> -W4 4 Way (Default)
------------------------------------	---	--	------------------------------------	--

<input type="checkbox"/> -A1 shown here in dotted line	<input type="checkbox"/> -AC shown here in dotted line	<input type="checkbox"/> -A0 shown here in dotted line	<input type="checkbox"/> -A3 shown here in dotted line	<input type="checkbox"/> -A4 shown here in dotted line
--	--	--	--	--

✓	Model #	Listed Size	Neck Size B	Face Size
	DLA 0606	6" x 6"	5 15/16" x 5 15/16"	11 3/4" x 11 3/4"
	DLA 0909	9" x 9"	8 15/16" x 8 15/16"	14 3/4" x 14 3/4"
	DLA 1212	12" x 12"	11 15/16" x 11 15/16"	17 3/4" x 17 3/4"
	DLA 1515	15" x 15"	14 15/16" x 14 15/16"	20 3/4" x 20 3/4"
	DLA 1818	18" x 18"	17 15/16" x 17 15/16"	23 3/4" x 23 3/4"
	DLA9 0606	6" x 6"	6 3/16" x 6 3/16"	11 3/4" x 11 3/4"
	DLA9 0909	9" x 9"	9 3/16" x 9 3/16"	14 3/4" x 14 3/4"
	DLA9 1212	12" x 12"	12 3/16" x 12 3/16"	17 3/4" x 17 3/4"
	DLA9 1515	15" x 15"	14 3/16" x 14 3/16"	20 3/4" x 20 3/4"
	DLA9 1818	18" x 18"	17 3/16" x 17 3/16"	23 3/4" x 23 3/4"

Plaque options Only with -W4

<input type="checkbox"/> -PQ1	<input type="checkbox"/> -PQ2	<input type="checkbox"/> -PQ3	<input type="checkbox"/> -PQ4
-------------------------------	-------------------------------	-------------------------------	-------------------------------

Finish

<input type="checkbox"/> /W White (Default)	<input type="checkbox"/> /C Custom (Please Specify)
---	---



Panel Option for T-bar lay-in Ceiling

	Steel (WxH)	Aluminum (WxH)
	<input type="checkbox"/> -X2412	<input type="checkbox"/> -Y2412
	<input type="checkbox"/> -X2424	<input type="checkbox"/> -Y2424
	<input type="checkbox"/> -X4812	<input type="checkbox"/> -Y4812
	<input type="checkbox"/> -X4824	<input type="checkbox"/> -Y4824

No mounting options available

Schedule type: _____

Job: _____

Architect: _____

Engineer: _____

Contractor: _____

Ceiling Diffuser - Aluminum Louvered Face Directional Fixed Air Pattern, Insulated Back

Material: Heavy gauge aluminum and molded fiberglass.
Finish: Powder paint coating - white.
Mounting: Lay-in T-bar ceiling.

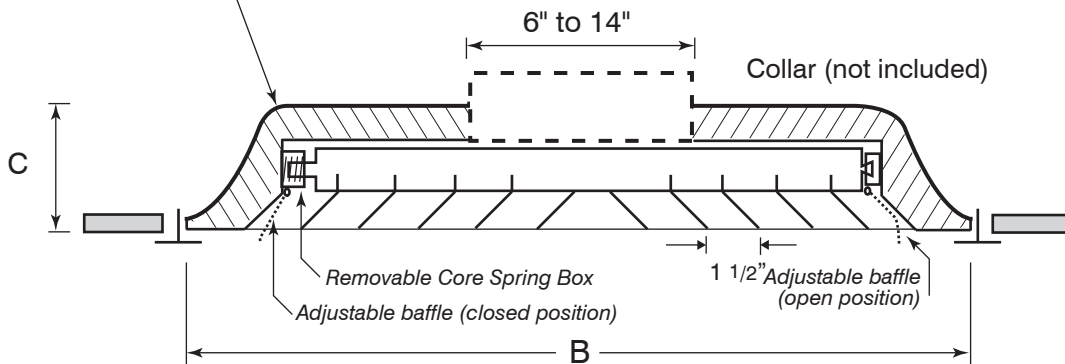
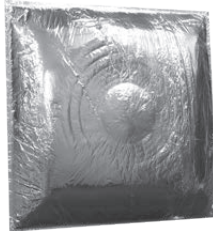


DLAI

SUBMITTAL SHEET

R6 fiberglass back complies with A.S.T.M. E84 flame and smoke test.

Scored for collar sizes up to 14" D.
Contractor to install job-specific collar in field.



Model #	Face Dim B x B	C
DLAI	23 3/4" x 23 3/4"	3 7/8"

Finish	
<input type="checkbox"/> /W White (Default)	<input type="checkbox"/> /C Custom _____ (Please Specify)



Core Selection (-W) & Adjustable Baffles (-A)				
-W1 1 Way	-WC 2 Way Corner	-WO 2 Way Opposed	-W3 3 Way	-W4 4 Way (Default)
-A1 shown here in dotted line	-AC shown here in dotted line	-AO shown here in dotted line	-A3 shown here in dotted line	-A4 shown here in dotted line

Schedule type: _____

Job: _____

Architect: _____

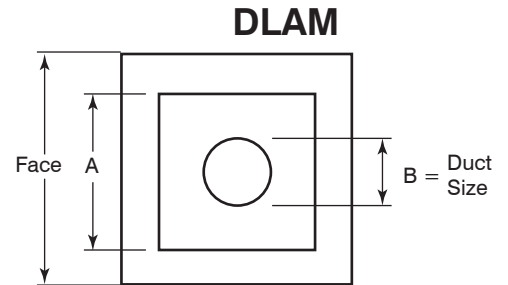
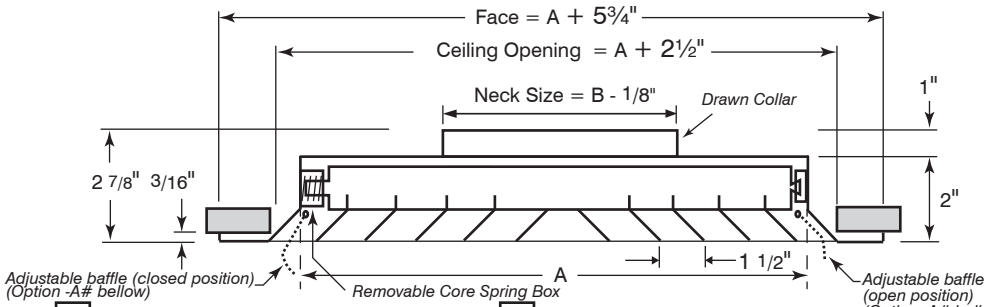
Engineer: _____

Contractor: _____

SUBMITTAL SHEET

Ceiling Diffuser - Aluminum Louvered Face Directional Fixed Air Pattern, Round Neck

Material: Heavy gauge aluminum.
Finish: Powder paint coating - white.
Mounting: Surface or Lay-in T-bar ceiling.
Volume Control: Available with pre-installed opposed blade damper (Model# DLAM4) or radial sliding blade damper (Model# DLAM5).



- DLAM** No Damper
- DLAM4** Pre-Installed N4 Opposed Blade Damper
- DLAM5** Pre-Installed N5 Radial Sliding Blade Damper

Border Type

- F** Flat Frame (Default)
- B** Beveled Frame

Mounting

- NT** Narrow T-bar
- O** Lay-In
- 1** Screw Holes
- 4** Concealed

Core Selection (-W) & Adjustable Baffles (-A)

- W1** 1 Way
- WC** 2 Way Corner
- WO** 2 Way Opposed
- W3** 3 Way
- W4** 4 Way (Default)

Adjustable Baffles (-A): -A1, -AC, -AO, -A3, -A4 (shown here in dotted line)

Finish

- /W** White (Default)
- /C** Custom (Please Specify)

Panel Option for T-bar lay-in Ceiling

	Steel (WxH)	Aluminum (WxH)
<input type="checkbox"/> -X1224	<input type="checkbox"/> -Y1224	
<input type="checkbox"/> -X2412	<input type="checkbox"/> -Y2412	
<input type="checkbox"/> -X2424	<input type="checkbox"/> -Y2424	
<input type="checkbox"/> -X2448	<input type="checkbox"/> -Y2448	
<input type="checkbox"/> -X4824	<input type="checkbox"/> -Y4824	
<input type="checkbox"/> -X2020	<input type="checkbox"/> -Y2020	

No fastening options available

- ES** Square Equalizing Grid

✓	Model #	A	B	Neck Size	Face Size
	0606 06	6 x 6	6	5 7/8	11 3/4 x 11 3/4
	0909 06	9 x 9	6	5 7/8	14 3/4 x 14 3/4
	0909 08	9 x 9	8	7 7/8	14 3/4 x 14 3/4
	1212 06	12 x 12	6	5 7/8	17 3/4 x 17 3/4
	1212 08	12 x 12	8	7 7/8	17 3/4 x 17 3/4
	1212 10	12 x 12	10	9 7/8	17 3/4 x 17 3/4
	1212 12	12 x 12	12	11 7/8	17 3/4 x 17 3/4
	1515 06	15 x 15	6	5 7/8	20 3/4 x 20 3/4
	1515 08	15 x 15	8	7 7/8	20 3/4 x 20 3/4
	1515 10	15 x 15	10	9 7/8	20 3/4 x 20 3/4
	1515 12	15 x 15	12	11 7/8	20 3/4 x 20 3/4
	1515 14 ¹	15 x 15	14	13 7/8	20 3/4 x 20 3/4
	1818 06	18 x 18	6	5 7/8	23 3/4 x 23 3/4
	1818 08	18 x 18	8	7 7/8	23 3/4 x 23 3/4
	1818 10	18 x 18	10	9 7/8	23 3/4 x 23 3/4
	1818 12	18 x 18	12	11 7/8	23 3/4 x 23 3/4
	1818 14 ¹	18 x 18	14	13 7/8	23 3/4 x 23 3/4
	1818 16 ²	18 x 18	16	15 7/8	23 3/4 x 23 3/4

¹ Size not available for DLAM5 ² Size not available for DLAM4 and DLAM5

Schedule type: _____

Job: _____

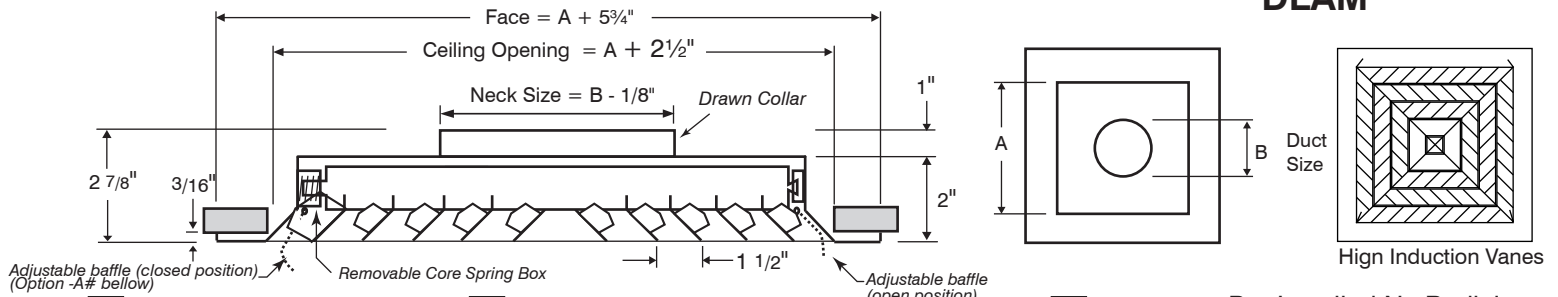
Architect: _____

Engineer: _____

Contractor: _____

Ceiling Diffuser - Aluminum Louvered Face Directional Fixed Air Pattern, Round Neck

- Material:** Heavy gauge aluminum.
Finish: Powder paint coating - white.
Mounting: Surface or Lay-in T-bar ceiling.
Volume Control: Available with pre-installed opposed blade damper (Model# DLAM4-HI) or radial sliding blade damper (Model# DLAM5-HI).


DLAM


- DLAM-HI** No Damper
 DLAM4-HI Pre-Installed N4 Opposed Blade Damper
 DLAM5 Pre-Installed N5 Radial Sliding Blade Damper

Border Type

-F Flat Frame (Default)
 -B Beveled Frame

Mounting

-NT Narrow T-bar
 -O Lay-in
 -1 Screw Holes
 -4 Concealed

Core Selection (-W) & Adjustable Baffles (-A)

-W1 1 Way
 -WC 2 Way Corner
 -WO 2 Way Opposed
 -W3 3 Way
 -W4 4 Way (Default)

-A1 shown here in dotted line
 -AC shown here in dotted line
 -AO shown here in dotted line
 -A3 shown here in dotted line
 -A4 shown here in dotted line

Finish

/W White (Default)
 /C Custom (Please Specify)

Panel Option for T-bar lay-in Ceiling

	Steel (WxH)	Aluminum (WxH)
<input type="checkbox"/>	-X1224	<input type="checkbox"/> -Y1224
<input type="checkbox"/>	-X2412	<input type="checkbox"/> -Y2412
<input type="checkbox"/>	-X2424	<input type="checkbox"/> -Y2424
<input type="checkbox"/>	-X2448	<input type="checkbox"/> -Y2448
<input type="checkbox"/>	-X4824	<input type="checkbox"/> -Y4824
<input type="checkbox"/>	-X2020	<input type="checkbox"/> -Y2020

No fastening options available

-ES Square Equalizing Grid

✓	Model #	A	B	Neck Size	Face Size
	0606 06	6 x 6	6	5 7/8	11 3/4 x 11 3/4
	0909 06	9 x 9	6	5 7/8	14 3/4 x 14 3/4
	0909 08	9 x 9	8	7 7/8	14 3/4 x 14 3/4
	1212 06	12 x 12	6	5 7/8	17 3/4 x 17 3/4
	1212 08	12 x 12	8	7 7/8	17 3/4 x 17 3/4
	1212 10	12 x 12	10	9 7/8	17 3/4 x 17 3/4
	1212 12	12 x 12	12	11 7/8	17 3/4 x 17 3/4
	1515 06	15 x 15	6	5 7/8	20 3/4 x 20 3/4
	1515 08	15 x 15	8	7 7/8	20 3/4 x 20 3/4
	1515 10	15 x 15	10	9 7/8	20 3/4 x 20 3/4
	1515 12	15 x 15	12	11 7/8	20 3/4 x 20 3/4
	1515 14¹	15 x 15	14	13 7/8	20 3/4 x 20 3/4
	1818 06	18 x 18	6	5 7/8	23 3/4 x 23 3/4
	1818 08	18 x 18	8	7 7/8	23 3/4 x 23 3/4
	1818 10	18 x 18	10	9 7/8	23 3/4 x 23 3/4
	1818 12	18 x 18	12	11 7/8	23 3/4 x 23 3/4
	1818 14¹	18 x 18	14	13 7/8	23 3/4 x 23 3/4
	1818 16²	18 x 18	16	15 7/8	23 3/4 x 23 3/4

¹ Size not available for DLAM5 ² Size not available for DLAM4 and DLAM5

Schedule type: _____

Job: _____

Architect: _____

Engineer: _____

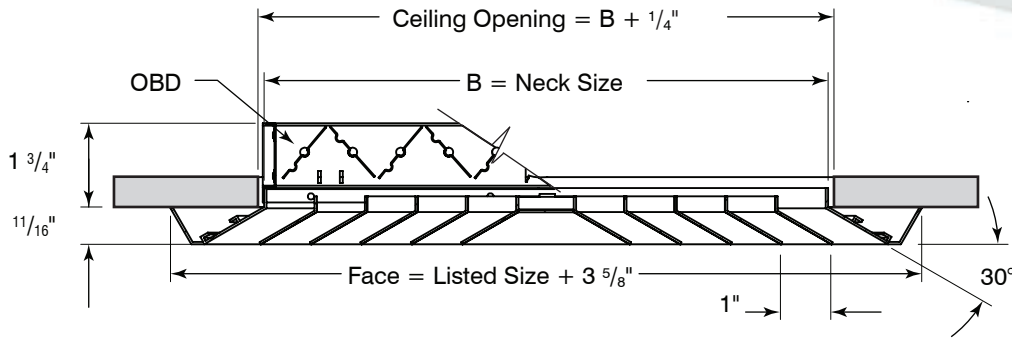
Contractor: _____

Diffuser (Louvered) Light Commercial

- Material:** Heavy gauge aluminum.
- Finish:** Powder paint coating - white.
- Mounting:** Surface mount.
- Volume Control:** Available with pre-installed aluminum OBD (Model# DLC7).



DLC



-ES Square Equalizing Grid

Border Type	
<input type="checkbox"/> -F Flat Frame (Default) 	<input type="checkbox"/> -B Beveled Frame

Mounting			
<input type="checkbox"/> -NT Narrow T-bar 	<input type="checkbox"/> -O Lay-In 	<input type="checkbox"/> -1 Screw Holes 	<input type="checkbox"/> -4 Concealed

Core Selection (-W) & Adjustable Baffles (-A)				
<input type="checkbox"/> -W1 1 Way 	<input type="checkbox"/> -WC 2 Way Corner 	<input type="checkbox"/> -WO 2 Way Opposed 	<input type="checkbox"/> -W3 3 Way 	<input type="checkbox"/> -W4 4 Way (Default)
-A1 shown here in dotted line	-AC shown here in dotted line	-A0 shown here in dotted line	-A3 shown here in dotted line	-A4 shown here in dotted line

Panel Option for T-bar lay-in Ceiling											
	<table style="width: 100%;"> <tr> <th style="text-align: left;">Steel (WxH)</th> <th style="text-align: left;">Aluminum (WxH)</th> </tr> <tr> <td><input type="checkbox"/> -X2412</td> <td><input type="checkbox"/> -Y2412</td> </tr> <tr> <td><input type="checkbox"/> -X2424</td> <td><input type="checkbox"/> -Y2424</td> </tr> <tr> <td><input type="checkbox"/> -X4812</td> <td><input type="checkbox"/> -Y4812</td> </tr> <tr> <td><input type="checkbox"/> -X4824</td> <td><input type="checkbox"/> -Y4824</td> </tr> </table>	Steel (WxH)	Aluminum (WxH)	<input type="checkbox"/> -X2412	<input type="checkbox"/> -Y2412	<input type="checkbox"/> -X2424	<input type="checkbox"/> -Y2424	<input type="checkbox"/> -X4812	<input type="checkbox"/> -Y4812	<input type="checkbox"/> -X4824	<input type="checkbox"/> -Y4824
Steel (WxH)	Aluminum (WxH)										
<input type="checkbox"/> -X2412	<input type="checkbox"/> -Y2412										
<input type="checkbox"/> -X2424	<input type="checkbox"/> -Y2424										
<input type="checkbox"/> -X4812	<input type="checkbox"/> -Y4812										
<input type="checkbox"/> -X4824	<input type="checkbox"/> -Y4824										
No mounting options available											

	Model #	Listed Size	Neck Size B	Face Size
✓	DLC 0606	6" x 6" (152 x 152)	5 3/4" x 5 3/4" (146 x 146)	9 5/8" x 9 5/8" (245 x 245)
	DLC 0808	8" x 8" (203 x 203)	7 3/4" x 7 3/4" (197 x 197)	11 5/8" x 11 5/8" (296 x 296)
	DLC 1010	10" x 10" (254 x 254)	9 3/4" x 9 3/4" (248 x 248)	13 5/8" x 13 5/8" (347 x 347)
	DLC 1212	12" x 12" (305 x 305)	11 3/4" x 11 3/4" (298 x 298)	15 5/8" x 15 5/8" (398 x 398)

Plaque options Only with -W4				
<input type="checkbox"/> -PQ1	<input type="checkbox"/> -PQ2	<input type="checkbox"/> -PQ3	<input type="checkbox"/> -PQ4	

Finish	
<input type="checkbox"/> /W White (Default)	<input type="checkbox"/> /C Custom (Please Specify) _____



Schedule type: _____

Job: _____

Architect: _____

Engineer: _____

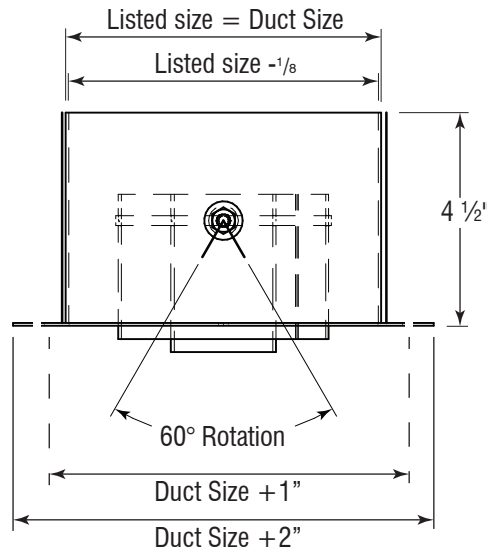
Contractor: _____

Concentric Ring Diffuser

- Material:** Powder coated heavy gauge steel.
Finish: Powder paint coating - white.
Air Pattern: Jetflow, 60° adjustable with hinge.
Mounting: Surface or open ceiling. Wall or side mounted.
Core Adjustment: Rotate the core upwards/downwards (or right/left) to adjust flow.


DRC18

SUBMITTAL SHEET



Model #	Duct Size
DRC 04	4"
DRC 05	5"
DRC 06	6"
DRC 08	8"
DRC 10	10"
DRC 12	12"
DRC 14	14"
DRC 15	15"
DRC 16	16"

Finish	
<input type="checkbox"/> /W White (Default)	<input type="checkbox"/> /C Custom (Please Specify) _____



Schedule type: _____
Job: _____
Architect: _____
Engineer: _____
Contractor: _____

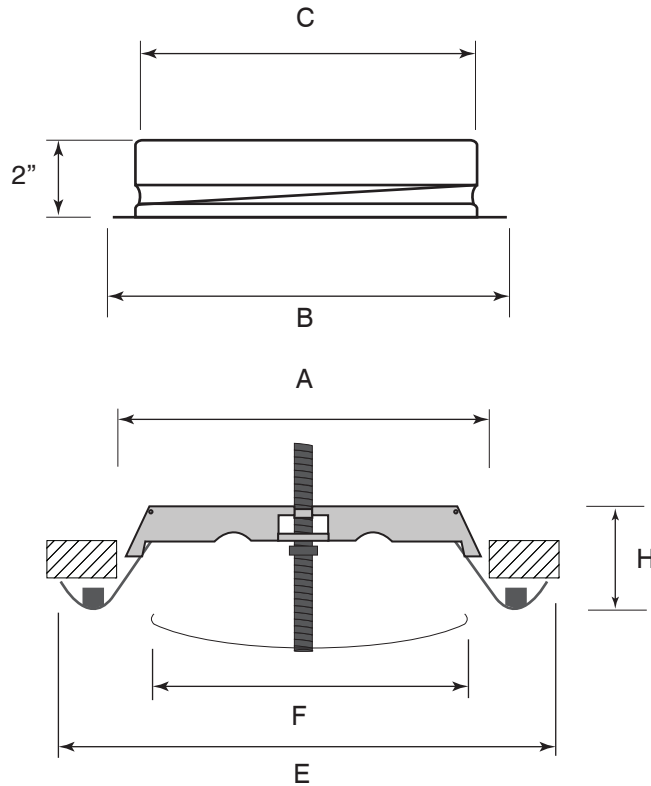
SUBMITTAL SHEET

Universal Valve Diffuser Pressed Steel, Adjustable Core

- Material:** Powder coated heavy gauge steel.
Galvanized steel mounting.
- Finish:** Powder paint coating - white.
- Air Pattern:** 360° diffusion, vertically adjustable.
- Mounting:** Surface or open ceiling.
- Core Adjustment:** Rotate the core clockwise or counterclockwise to adjust flow.



DRV



	Model	Duct Size	A	F	H	C	B	E
	DRV 03	3"	3.03	2.44"	1.58"	3.11"	4.13"	4.53"
	DRV 04	4"	4.09"	2.95"	1.57"	3.9"	4.92"	5.39"
	DRV 05	5"	5.08"	3.9"	1.81"	4.88"	5.91"	6.46"
	DRV 06	6"	6.65"	5.08"	2.13"	5.9"	6.91"	7.75"
	DRV 08	8"	8.23"	6.18"	2.48"	7.83"	8.85"	9.76"
	DRV 10	10"	10.45"	8.19"	2.19"	9.69"	11.28"	11.76"

Finish	
<input type="checkbox"/> /W	<input type="checkbox"/> /C Custom (Please Specify)
White (Default)	_____



Schedule type: _____

Job: _____

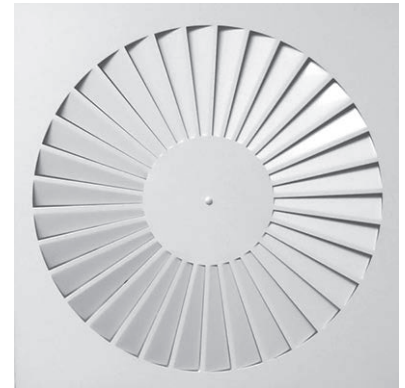
Architect: _____

Engineer: _____

Contractor: _____

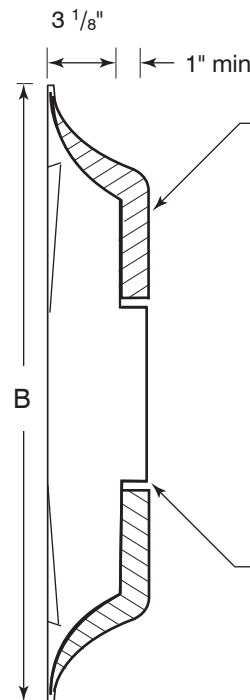
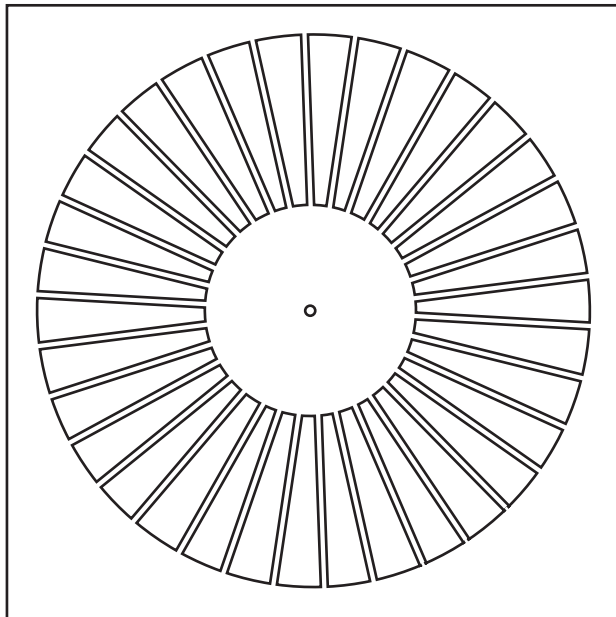
Swirl Face Supply Diffuser Fixed face

Material: Stamped heavy gauge steel.
Finish: Powder paint coating - white.
Air Pattern: Fixed 360° spiral pattern.
Mounting: Lay-in T-bar ceiling.



SUBMITTAL SHEET

DSW
All Aluminum



Optional fiberglass insulation on back panel, complies with A.S.T.M. E84 flame and smoke test. (Available only on models with 24" x 24" face)

-R4 -R6

Round collar up to 14".
Standard height is 1 1/8".
For 2" collar, see DSWD

✓	Model #	Duct Size	Neck Size	Face Dim B x B
	DSW 2406	6	5 7/8"	23 7/8" x 23 7/8"
	DSW 2408	8	7 7/8"	23 7/8" x 23 7/8"
	DSW 2410	10	9 7/8"	23 7/8" x 23 7/8"
	DSW 2412	12	11 7/8"	23 7/8" x 23 7/8"
	DSW 2414	14	13 7/8"	23 7/8" x 23 7/8"

Finish	
<input type="checkbox"/> /W White (Default)	<input type="checkbox"/> /C Custom (Please Specify)



Schedule type: _____

Job: _____

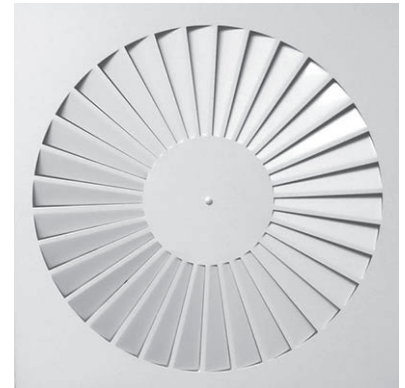
Architect: _____

Engineer: _____

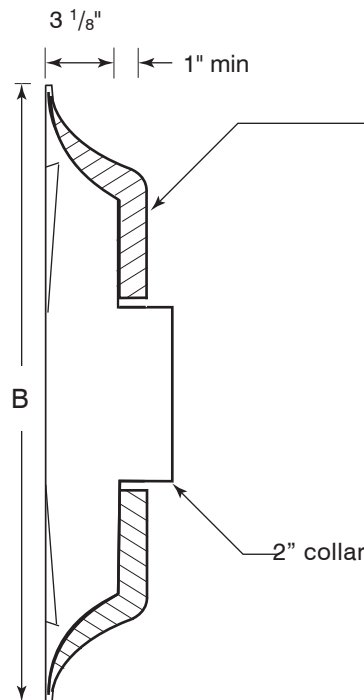
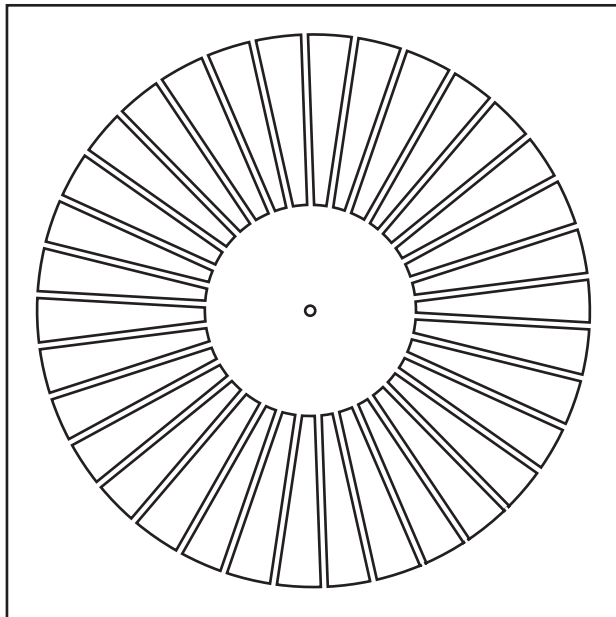
Contractor: _____

Swirl Face Supply Diffuser Fixed face - 2" Collar

Material: Stamped heavy gauge steel.
Finish: Powder paint coating - white.
Air Pattern: Fixed 360° spiral pattern.
Mounting: Lay-in T-bar ceiling.



DSWD
All Aluminum



Optional fiberglass insulation on back panel, complies with A.S.T.M. E84 flame and smoke test. (Available only on models with 24" x 24" face)

-R4 -R6

✓	Model #	Duct Size	Neck Size	Face Dim B x B
	DSWD 2406	6	5 7/8"	23 7/8" x 23 7/8"
	DSWD 2408	8	7 7/8"	23 7/8" x 23 7/8"
	DSWD 2410	10	9 7/8"	23 7/8" x 23 7/8"
	DSWD 2412	12	11 7/8"	23 7/8" x 23 7/8"
	DSWD 2414	14	13 7/8"	23 7/8" x 23 7/8"

Finish	
<input type="checkbox"/> /W White (Default)	<input type="checkbox"/> /C Custom (Please Specify)



Schedule type: _____

Job: _____

Architect: _____

Engineer: _____

Contractor: _____

Swirl Face Supply Diffuser Fixed face

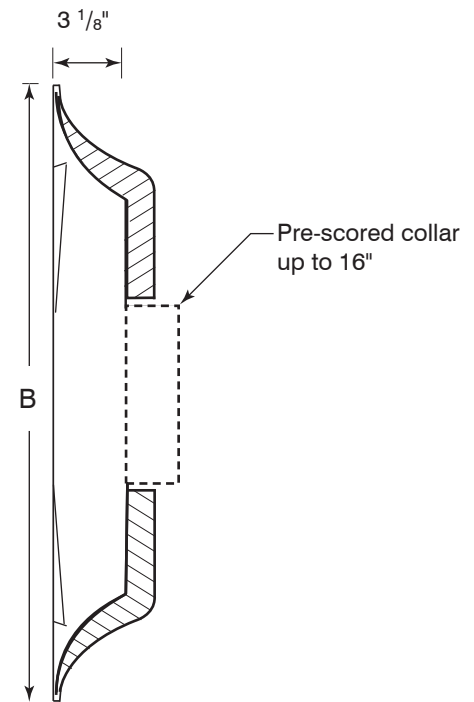
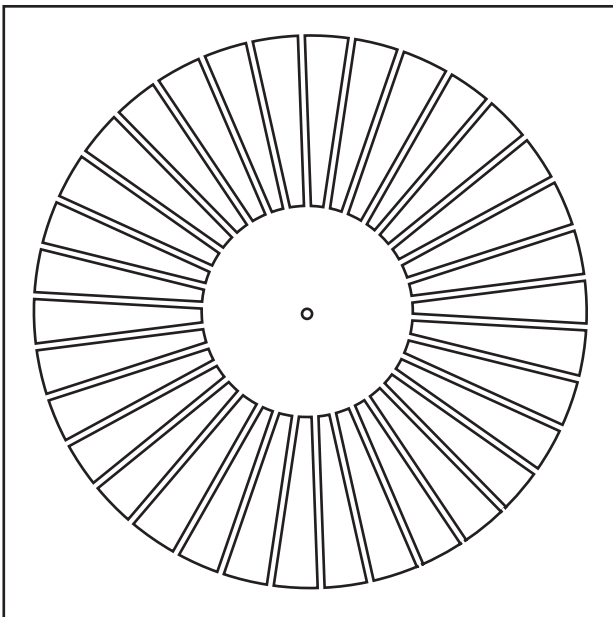
Material: Stamped heavy gauge steel back panel.
Finish: Powder paint coating - white.
Air Pattern: Fixed 360° spiral pattern.
Mounting: Lay-in T-bar ceiling.
Insulation: R6 Molded Fiberglass.



SUBMITTAL SHEET

ADSWI
 All Aluminum

Fiberglass back complies with
 A.S.T.M. E84 flame and smoke test.
 Scored for collar sizes up to 14" D.



Finish	
<input type="checkbox"/> /W	<input type="checkbox"/> /C Custom (Please Specify)
White (Default)	_____



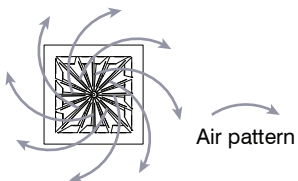
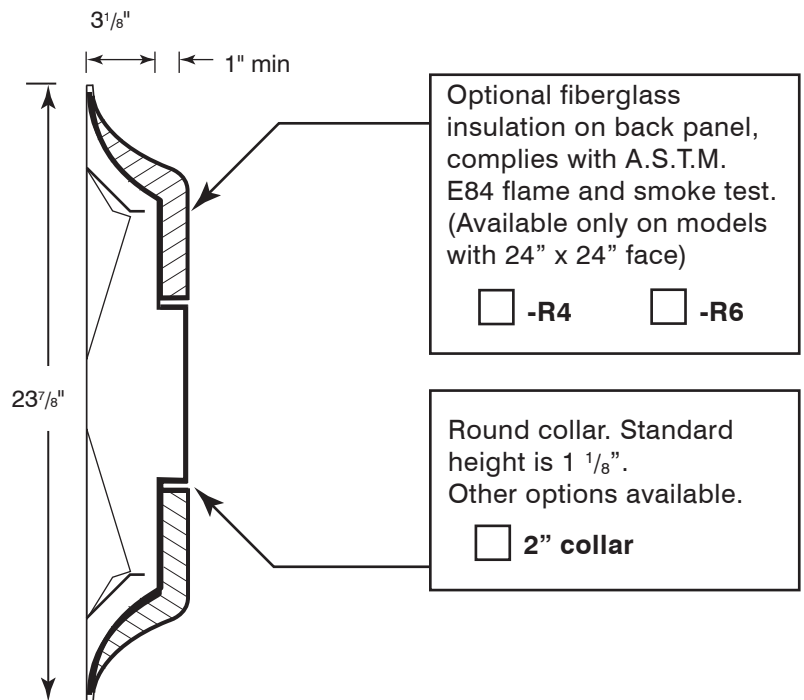
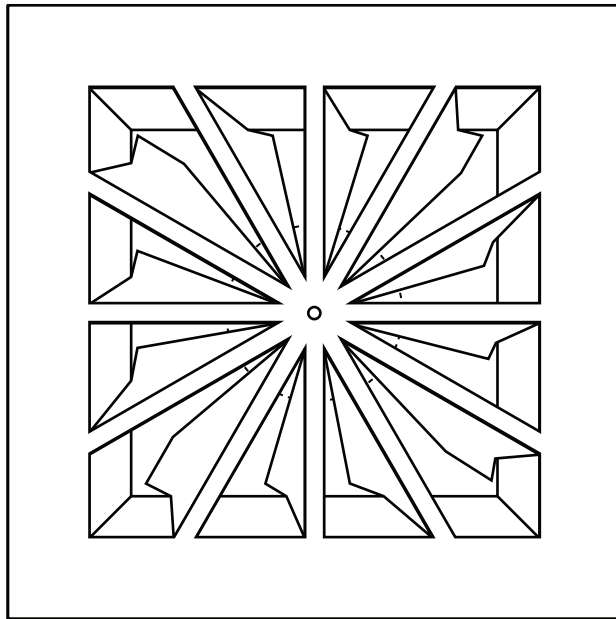
Schedule type: _____
 Job: _____
 Architect: _____
 Engineer: _____
 Contractor: _____

Stamped Twist Diffuser

Finish: Stamped heavy gauge steel.
Material: Powder paint coating - white.
Air Pattern: Fixed 360° spiral pattern.
Mounting: Lay-in T-bar ceiling.



DTW



✓	Model #	Duct Size	Neck Size	Face Dim B x B
	DTW 2406	6	5 7/8"	23 7/8" x 23 7/8"
	DTW 2408	8	7 7/8"	23 7/8" x 23 7/8"
	DTW 2410	10	9 7/8"	23 7/8" x 23 7/8"
	DTW 2412	12	11 7/8"	23 7/8" x 23 7/8"
	DTW 2414	14	13 7/8"	23 7/8" x 23 7/8"

Finish	
<input type="checkbox"/> /W White (Default)	<input type="checkbox"/> /C Custom (Please Specify)



Schedule type: _____

Job: _____

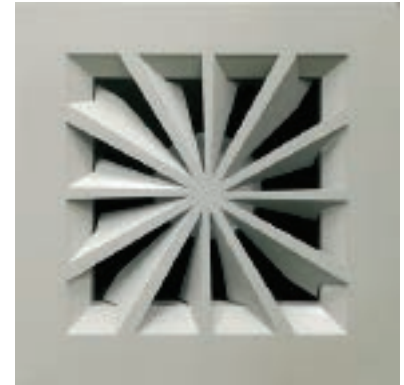
Architect: _____

Engineer: _____

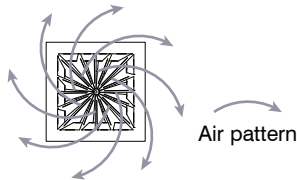
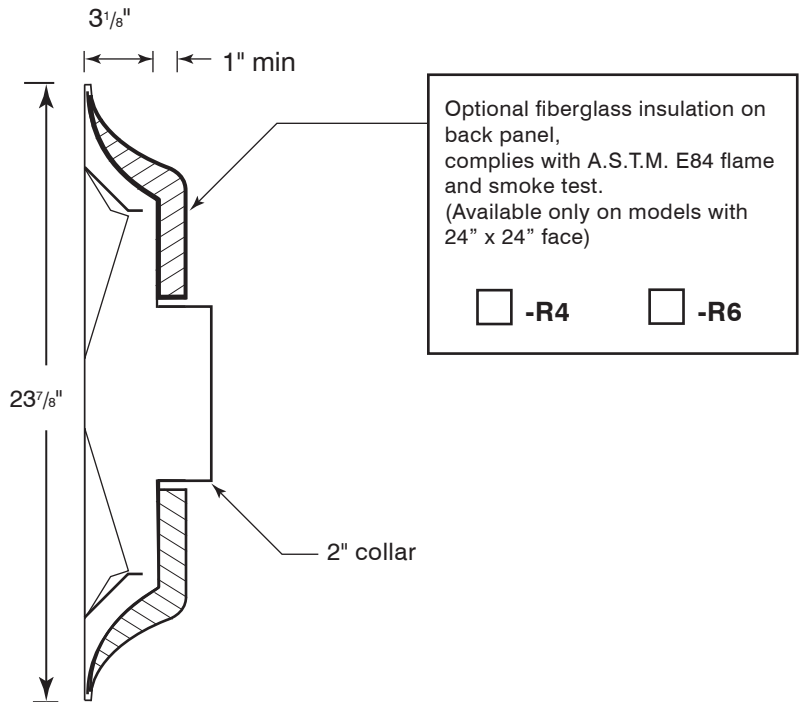
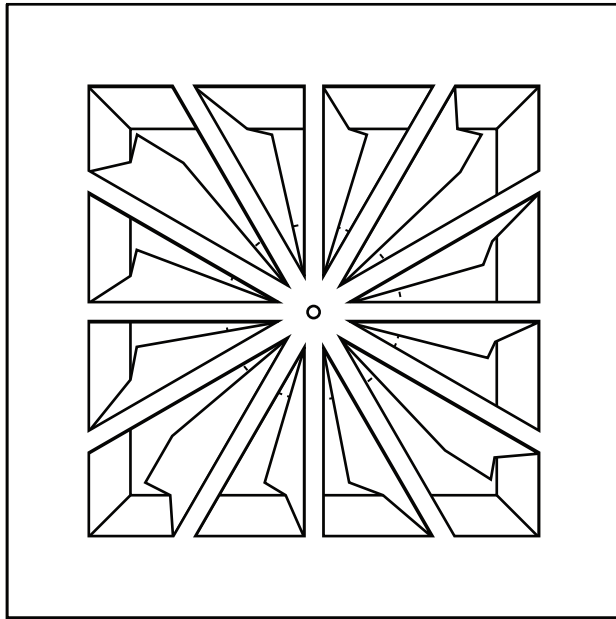
Contractor: _____

Stamped Twist Diffuser Fixed face - 2" Collar

Finish: Stamped heavy gauge steel.
Material: Powder paint coating - white.
Air Pattern: Fixed 360° spiral pattern.
Mounting: Lay-in T-bar ceiling.


DTWD

SUBMITTAL SHEET



Finish	
<input type="checkbox"/> /W White (Default)	<input type="checkbox"/> /C Custom (Please Specify)



Schedule type: _____

Job: _____

Architect: _____

Engineer: _____

Contractor: _____

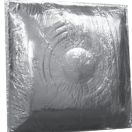
SUBMITTAL SHEET

Stamped Twist Diffuser Fixed Face - Fiberglass Insulation

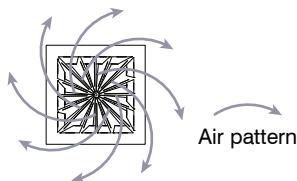
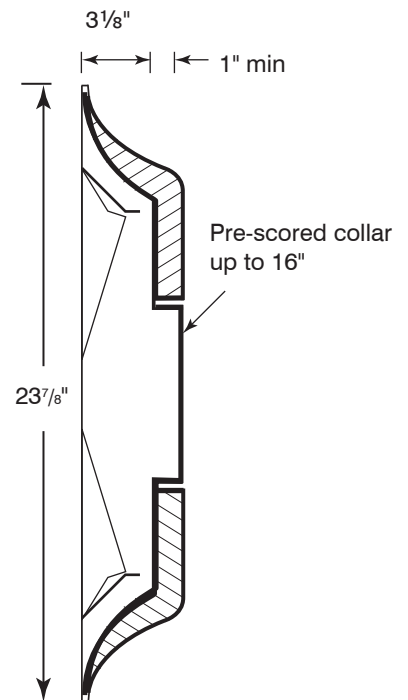
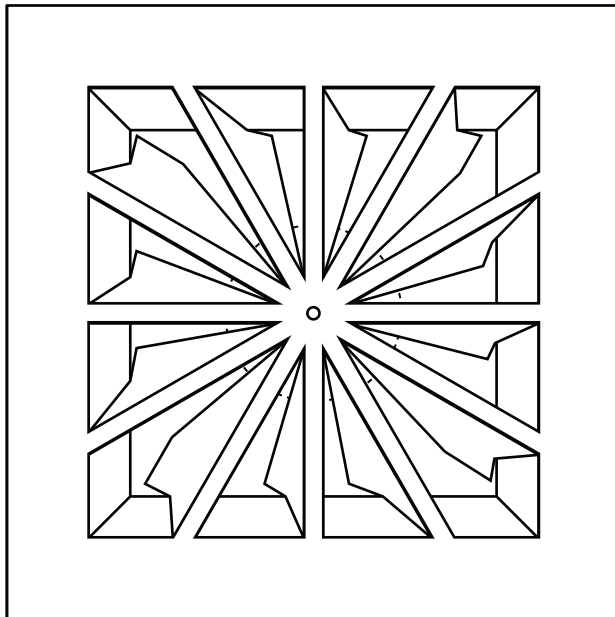
- Finish:** Stamped heavy gauge steel.back panel.
- Material:** Powder paint coating - white.
- Air Pattern:** Fixed 360° spiral pattern.
- Mounting:** Lay-in T-bar ceiling.
- Insulation:** R6 Molded Fiberglass.



DTWI



Fiberglass back complies with A.S.T.M. E84 flame and smoke test. Scored for collar sizes up to 14" D.



Finish	
<input type="checkbox"/> /W White (Default)	<input type="checkbox"/> /C Custom (Please Specify)



Schedule type: _____

Job: _____

Architect: _____

Engineer: _____

Contractor: _____

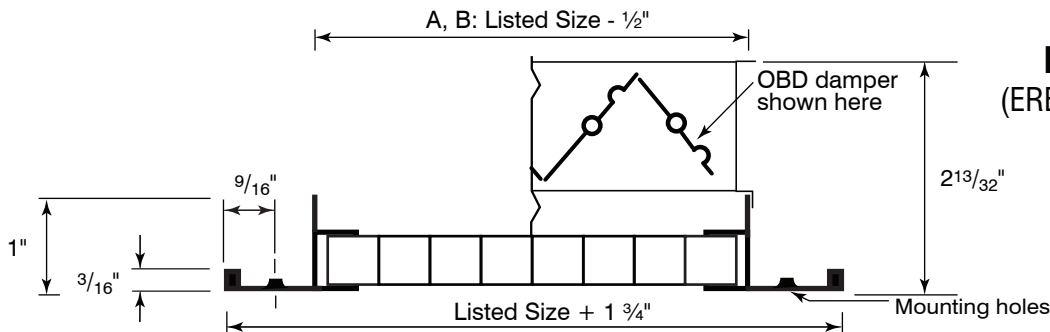
Egg Crate Return Grille for Surface Mount

- Material:** All aluminium construction.
- Mounting:** Drywall or any surface mounting.
Countersunk mounting holes on frame.
- Grid core:** Aluminum 1/2" x 1/2" x 1/2".



SUBMITTAL SHEET

- ERE** (without OBD damper) **ERE7** (with OBD damper)

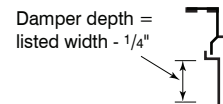
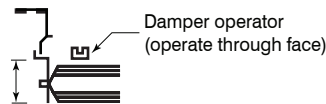


ERE / ERE7
(ERE 2424 shown here)

Size limits	Width A		Height B	
	in	mm	in	mm
Minimum	4	102	4	102
Maximum	48	1219	48	1219

#7 STEEL DAMPER FURNISHED ON LISTED WIDTHS OF 4" AND OVER (for 1" increments only)

#9 STEEL DAMPER FURNISHED ON LISTED WIDTHS UNDER 4"



Options			
-GK Flange Gasket	-GN Neck Gasket	-GR Rear Gasket	
-SF Supplied w/ sub frame	-DS Debris (Bird) Screen	-IS Insect Screen	-FB Fixed Blades 0 degrees

Fastening Method				
-1 No Fastening	-2 Spring clip	-3 Screw holes (Standard)	-4 Concealed	-6 Adhesive tape

Panel Option for T-bar lay-in Ceiling

	Steel (WxH)	Aluminum (WxH)
<input type="checkbox"/>	-X1212	-Y1212
<input type="checkbox"/>	-X1224	-Y1224
<input type="checkbox"/>	-X2412	-Y2412
<input type="checkbox"/>	-X2424	-Y2424
<input type="checkbox"/>	-X2448	-Y2448
<input type="checkbox"/>	-X4824	-Y4824
<input type="checkbox"/>	-X2020	-Y2020

No fastening options available

Finish				
<input type="checkbox"/> /W White (default)	<input type="checkbox"/> /B Brushed Aluminum	<input type="checkbox"/> /M Mill Finish	<input type="checkbox"/> /L Brushed & Lacquered	<input type="checkbox"/> /C Custom (Please Specify)



Schedule type: _____

Job: _____

Architect: _____

Engineer: _____

Contractor: _____

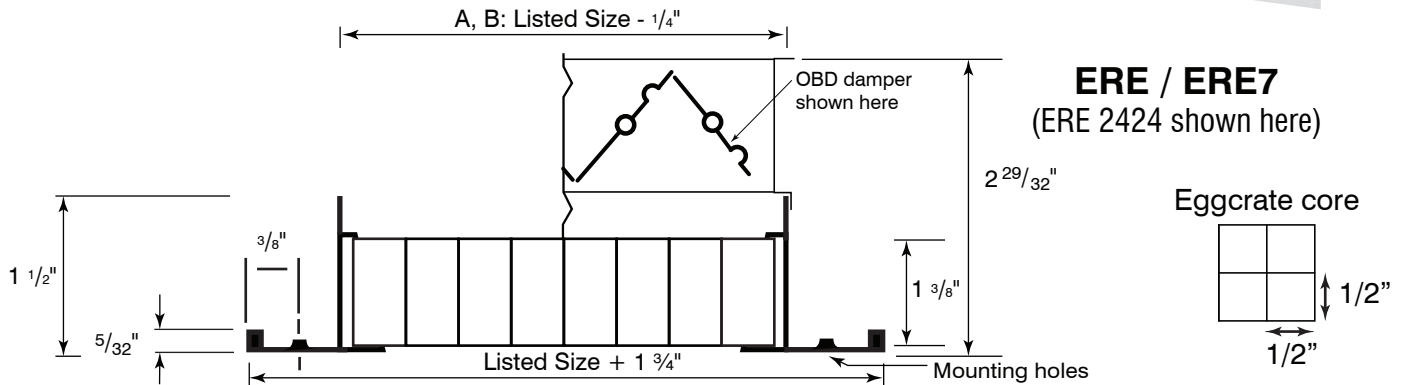
SUBMITTAL SHEET

Eggcrate Return Grille for Surface Mount

- Material:** All aluminium construction.
Mounting: Drywall or any surface mounting.
 Countersunk mounting holes on frame.
Grid core: Aluminum 1/2" x 1/2" x 1".



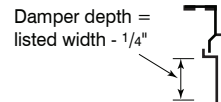
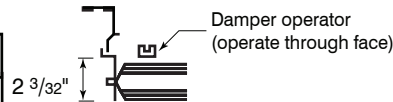
- ERE1** (without OBD damper) **ERE17** (with OBD damper)



Size limits	Width A		Height B	
	in	mm	in	mm
Minimum	4	102	4	102
Maximum	48	1219	48	1219

#7 STEEL DAMPER FURNISHED ON LISTED WIDTHS OF 4" AND OVER (for 1" increments only)

#9 STEEL DAMPER FURNISHED ON LISTED WIDTHS UNDER 4"



Options			
-GK Flange Gasket	-GN Neck Gasket	-GR Rear Gasket	
-SF Supplied w/ sub frame	-DS Debris (Bird) Screen	-IS Insect Screen	-FB Fixed Blades 0 degrees

Fastening Method				
-1 No Fastening	-2 Spring clip	-3 Screw holes (Standard)	-4 Concealed	-6 Adhesive tape

Panel Option for T-bar lay-in Ceiling

Steel (WxH)	Aluminum (WxH)
<input type="checkbox"/> -X1212	<input type="checkbox"/> -Y1212
<input type="checkbox"/> -X1224	<input type="checkbox"/> -Y1224
<input type="checkbox"/> -X2412	<input type="checkbox"/> -Y2412
<input type="checkbox"/> -X2424	<input type="checkbox"/> -Y2424
<input type="checkbox"/> -X2448	<input type="checkbox"/> -Y2448
<input type="checkbox"/> -X4824	<input type="checkbox"/> -Y4824
<input type="checkbox"/> -X2020	<input type="checkbox"/> -Y2020

No fastening options available

Finish				
<input type="checkbox"/> /W White (default)	<input type="checkbox"/> /B Brushed Aluminum	<input type="checkbox"/> /M Mill Finish	<input type="checkbox"/> /L Brushed & Lacquered	<input type="checkbox"/> /C Custom (Please Specify)



Schedule type: _____

Job: _____

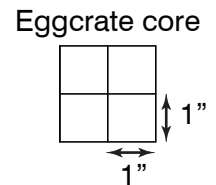
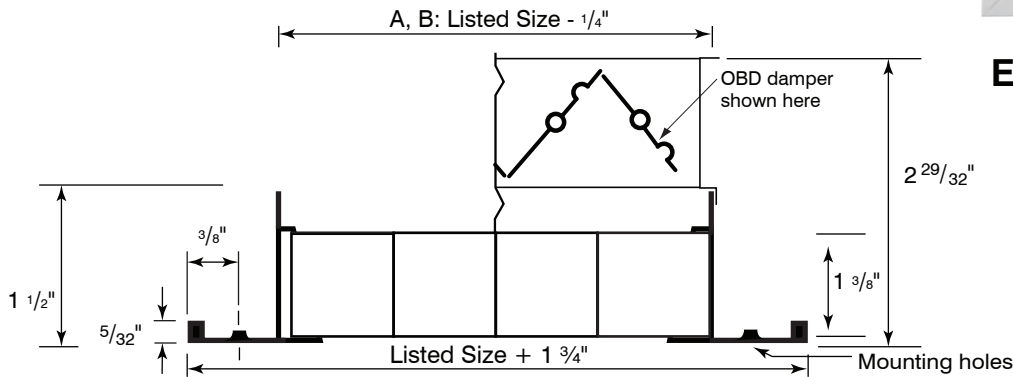
Architect: _____

Engineer: _____

Contractor: _____

Egg Crate Return Grille for Surface Mount 1" square cell size

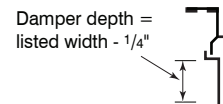
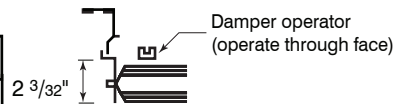
- Material:** All aluminium construction.
Mounting: Drywall or any surface mounting.
 Countersunk mounting holes on frame.
Grid core: Aluminum 1" x 1" x 1".


ERE3 / ERE37


Size limits	Width A		Height B	
	in	mm	in	mm
Minimum	4	102	4	102
Maximum	48	1219	48	1219

#7 STEEL DAMPER FURNISHED ON LISTED WIDTHS OF 4" AND OVER (for 1" increments only)

#9 STEEL DAMPER FURNISHED ON LISTED WIDTHS UNDER 4"



Options			
-GK Flange Gasket	-GN Neck Gasket	-GR Rear Gasket	
-SF Supplied w/ sub frame	-DS Debris (Bird) Screen	-IS Insect Screen	-FB Fixed Blades 0 degrees

Fastening Method				
-1 No Fastening	-2 Spring clip	-3 Screw holes (Standard)	-4 Concealed	-6 Adhesive tape

Panel Option for T-bar lay-in Ceiling

	Steel (WxH)	Aluminum (WxH)
	<input type="checkbox"/> -X1212	<input type="checkbox"/> -Y1212
	<input type="checkbox"/> -X1224	<input type="checkbox"/> -Y1224
	<input type="checkbox"/> -X2412	<input type="checkbox"/> -Y2412
	<input type="checkbox"/> -X2424	<input type="checkbox"/> -Y2424
	<input type="checkbox"/> -X2448	<input type="checkbox"/> -Y2448
	<input type="checkbox"/> -X4824	<input type="checkbox"/> -Y4824
	<input type="checkbox"/> -X2020	<input type="checkbox"/> -Y2020

No fastening options available

Finish				
<input type="checkbox"/> /W White (default)	<input type="checkbox"/> /B Brushed Aluminum	<input type="checkbox"/> /M Mill Finish	<input type="checkbox"/> /L Brushed & Lacquered	<input type="checkbox"/> /C Custom (Please Specify)

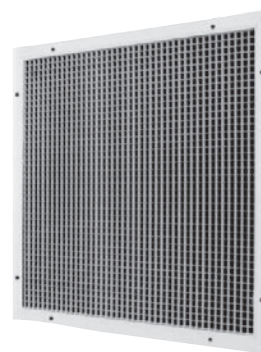


Schedule type: _____
 Job: _____
 Architect: _____
 Engineer: _____
 Contractor: _____

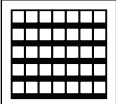
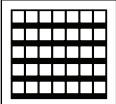
SUBMITTAL SHEET

Eggcrate Return Grille for Surface Mount 45° Angled Eggcrate

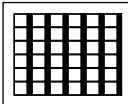
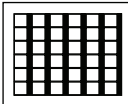
- Material:** All aluminium construction.
Mounting: Drywall or any surface mounting.
 Countersunk mounting holes on frame.
Grid core: Aluminum 1/2" x 1/2" x 1".



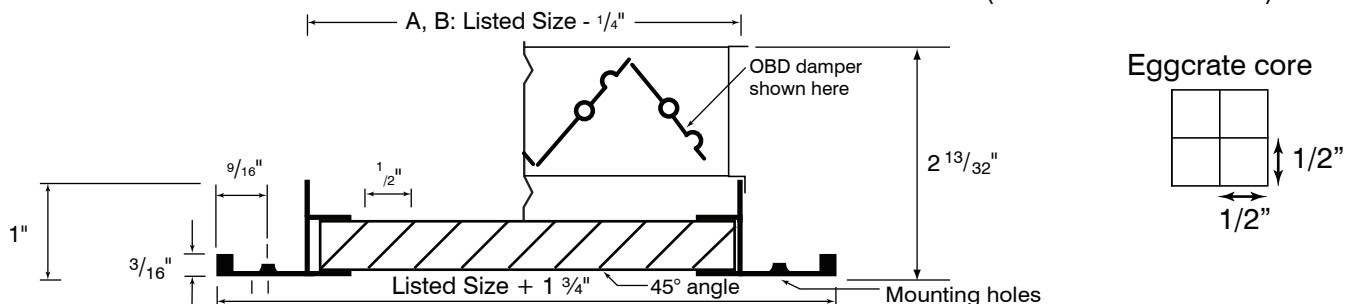
Horizontal Air Flow (Standard)

- ERE50** without OBD 
- ERE57** with OBD 

Vertical Face Bars

- ERE50-V** without OBD 
- ERE57-V** with OBD 

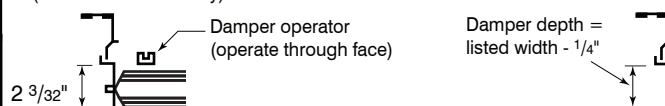
ERE5 / ERE57
(ERE 2424 shown here)



Size limits	Width A		Height B	
	in	mm	in	mm
Minimum	4	102	4	102
Maximum	48	1219	48	1219

#7 STEEL DAMPER FURNISHED ON LISTED WIDTHS OF 4" AND OVER (for 1" increments only)

#9 STEEL DAMPER FURNISHED ON LISTED WIDTHS UNDER 4"



Options			
-GK Flange Gasket	-GN Neck Gasket	-GR Rear Gasket	
-SF Supplied w/ sub frame	-DS Debris (Bird) Screen	-IS Insect Screen	-FB Fixed Blades 0 degrees

Fastening Method				
-1 No Fastening	-2 Spring clip	-3 Screw holes (Standard)	-4 Concealed	-6 Adhesive tape

Panel Option for T-bar lay-in Ceiling

	Steel (WxH)	Aluminum (WxH)
<input type="checkbox"/> -X1212	<input type="checkbox"/> -Y1212	
<input type="checkbox"/> -X1224	<input type="checkbox"/> -Y1224	
<input type="checkbox"/> -X2412	<input type="checkbox"/> -Y2412	
<input type="checkbox"/> -X2424	<input type="checkbox"/> -Y2424	
<input type="checkbox"/> -X2448	<input type="checkbox"/> -Y2448	
<input type="checkbox"/> -X4824	<input type="checkbox"/> -Y4824	
<input type="checkbox"/> -X2020	<input type="checkbox"/> -Y2020	

No fastening options available

Finish				
<input type="checkbox"/> /W White (default)	<input type="checkbox"/> /B Brushed Aluminum	<input type="checkbox"/> /M Mill Finish	<input type="checkbox"/> /L Brushed & Lacquered	<input type="checkbox"/> /C Custom (Please Specify)



Schedule type: _____

Job: _____

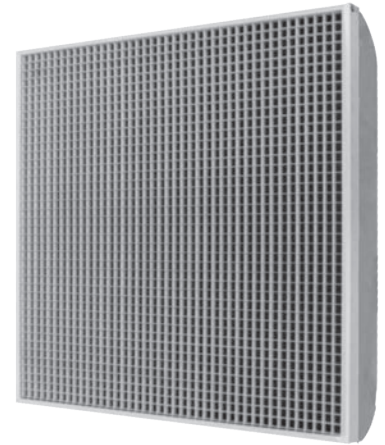
Architect: _____

Engineer: _____

Contractor: _____

Residential T-Bar Filter Return - Louvered Fixed air pattern

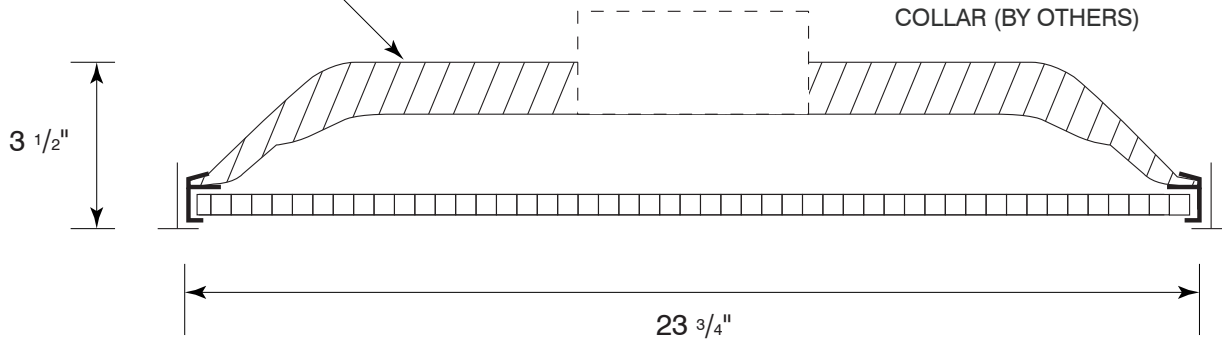
- Material:** Molded fiberglass back with aluminum foil vapor barrier scored for 6" to 14" D. in an extruded aluminum fixed frame.
- Grid core:** Aluminum 1/2" X 1/2" X 1/2".
- Finish:** Powder paint coating - white.
- Mounting:** T-bar Lay-in ceiling.


ERI

SUBMITTAL SHEET

Fiberglass back complies with
A.S.T.M. E84 flame and smoke test.
Scored for collar sizes up to 14" D.

 -R4

 -R6


Schedule type: _____

Job: _____

Architect: _____

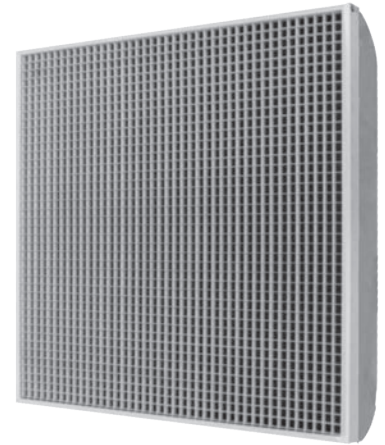
Engineer: _____

Contractor: _____

SUBMITTAL SHEET

Aluminum Egg Crate Return with Molded Fiberglass Back Panel 45° Angled Egg Crate

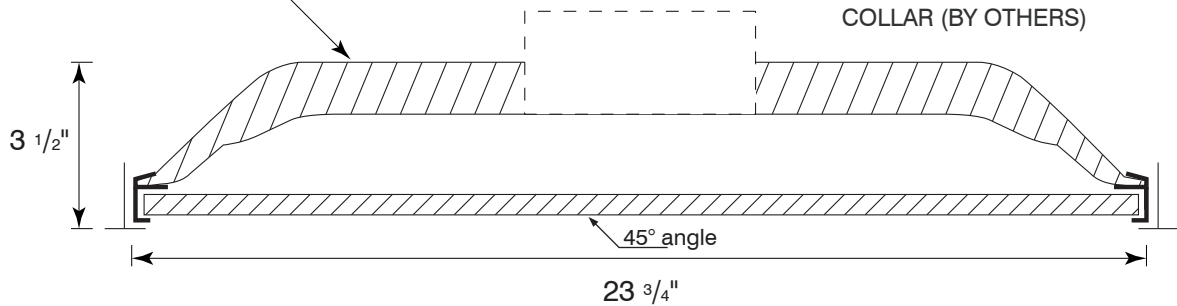
- Material:** Molded fiberglass back with aluminum foil vapor barrier scored for 6" to 14" D. in an extruded aluminum fixed frame.
- Grid core:** Aluminum 1/2" X 1/2" X 1/2" 45° Angled Eggcrate Core.
- Finish:** Powder paint coating - white.
- Mounting:** T-bar Lay-in ceiling.



ERI5

Fiberglass back complies with A.S.T.M. E84 flame and smoke test. Scored for collar sizes up to 14" D.

-R4 -R6



Schedule type: _____

Job: _____

Architect: _____

Engineer: _____

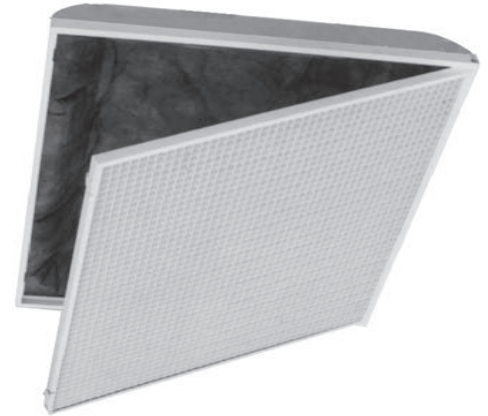
Contractor: _____

Aluminum Egg Crate Filter Return with Molded Fiberglass Back Panel Hinged face

Material: Molded fiberglass back with aluminum foil vapor barrier scored for 6" to 14" D. in an extruded aluminum fixed frame. Aluminum grid 1/2"x1/2"x1/2" in hinged extruded aluminum U frame, swing in and out of fixed frame for access to 20"x20" filter, by others.

Finish: Powder paint coating - white.

Mounting: T-bar Lay-in ceiling.

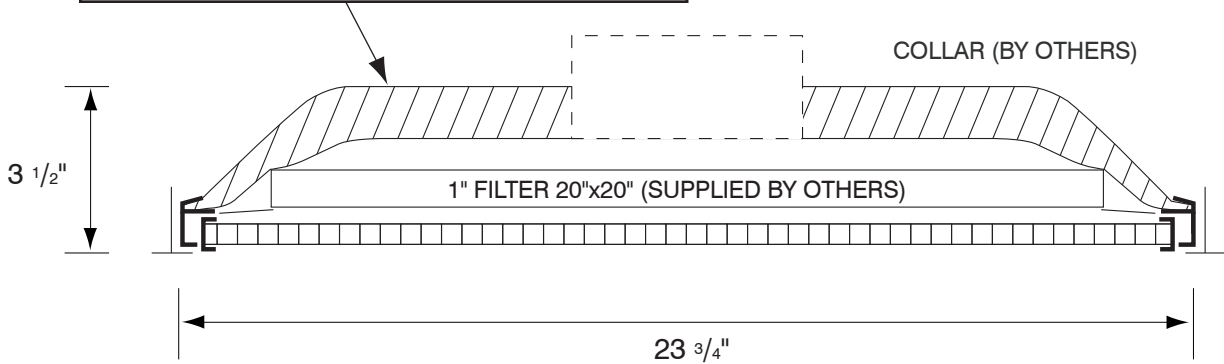


ERIF

SUBMITTAL SHEET

Fiberglass back complies with A.S.T.M. E84 flame and smoke test. Scored for collar sizes up to 14" D.

-R4 -R6



Schedule type: _____

Job: _____

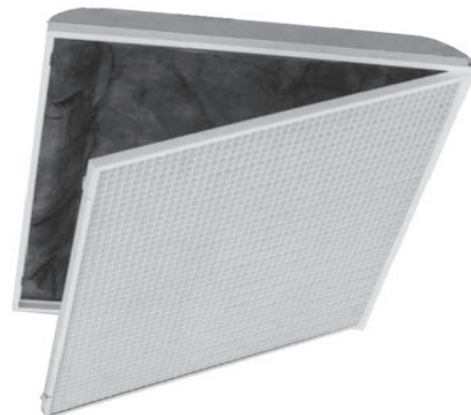
Architect: _____

Engineer: _____

Contractor: _____

SUBMITTAL SHEET

Aluminum Egg Crate Filter Return with Molded Fiberglass Back Panel Hinged face - 45° Angled Egg Crate



ERIF5

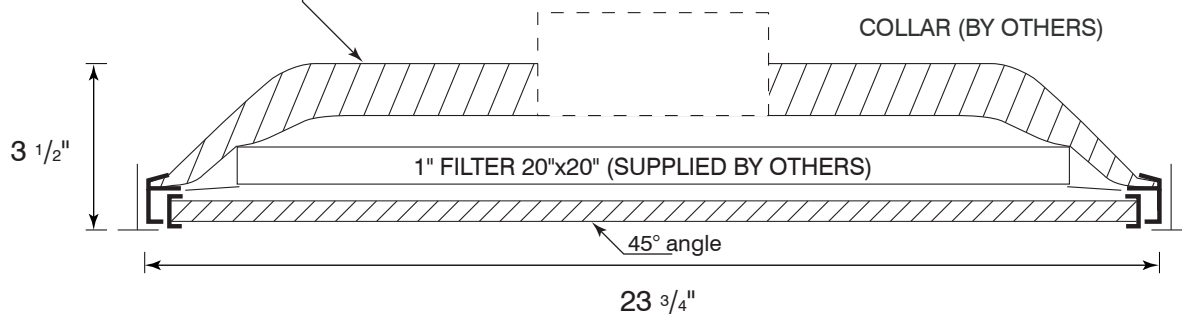
Material: Molded fiberglass back with aluminum foil vapor barrier scored for 6" to 14" D. in an extruded aluminum fixed frame. Aluminum grid 1/2"x1/2"x1/2" in hinged extruded aluminum U frame, swing in and out of fixed frame for access to 20"x20" filter, by others.

Finish: Powder paint coating - white.

Mounting: T-bar Lay-in ceiling.

Grid core: 45° Angled Eggcrate Core

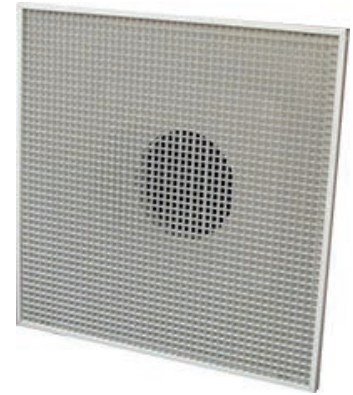
Fiberglass back complies with A.S.T.M. E84 flame and smoke test. Scored for collar sizes up to 14" D.
 -R4 -R6



Schedule type: _____
Job: _____
Architect: _____
Engineer: _____
Contractor: _____

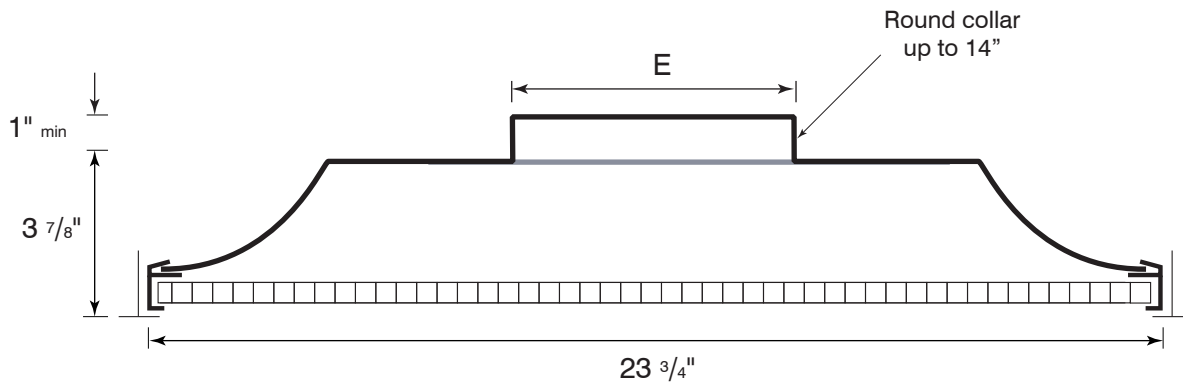
Aluminum Egg Crate Filter Return with Molded Fiberglass Back Panel Hinged face

- Material:** Stamped heavy gauge steel in an extruded aluminum fixed frame.
- Grid core:** Aluminum 1/2" x 1/2" x 1/2".
- Finish:** Powder paint coating - white.
- Safety:** Seismic tabs.
- Mounting:** T-bar Lay-in ceiling.



ERM

SUBMITTAL SHEET



✓	Model #	Duct Size	E	Face Dim
	ERM 1206	6	5 7/8"	11 3/4" x 11 3/4"
	ERM 1208	8	7 7/8"	11 3/4" x 11 3/4"
	ERM 2406	6	5 7/8"	23 3/4" x 23 3/4"
	ERM 2408	8	7 7/8"	23 3/4" x 23 3/4"
	ERM 2410	10	9 7/8"	23 3/4" x 23 3/4"
	ERM 2412	12	11 7/8"	23 3/4" x 23 3/4"
	ERM 2414	14	13 7/8"	23 3/4" x 23 3/4"
	ERM 2416	16	15 7/8"	23 3/4" x 23 3/4"

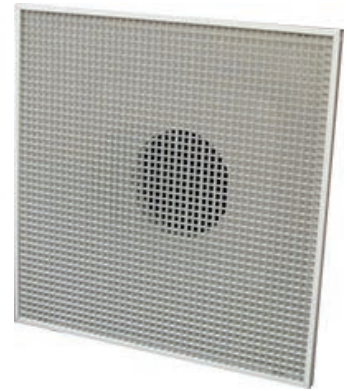
Finish	
<input type="checkbox"/> /W White (Default)	<input type="checkbox"/> /C Custom (Please Specify) _____



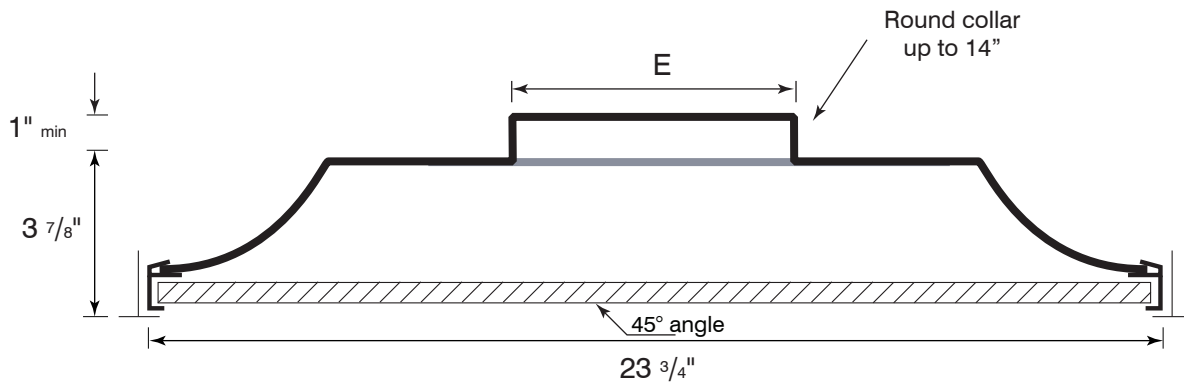
Schedule type: _____
Job: _____
Architect: _____
Engineer: _____
Contractor: _____

Aluminum Egg Crate Filter Return with Steel Back Panel 45° Angled Eggcrate

- Material:** Stamped heavy gauge steel in an extruded aluminum fixed frame.
- Grid core:** Aluminum 1/2" x 1/2" x 1/2" - 45° angled egg crate core.
- Finish:** Powder paint coating - white.
- Safety:** Seismic tabs.
- Mounting:** T-bar Lay-in ceiling.



ERM5



✓	Model #	Duct Size	E	Face Dim
	ERM5 1206	6	5 7/8"	11 3/4" x 11 3/4"
	ERM5 1208	8	7 7/8"	11 3/4" x 11 3/4"
	ERM5 2406	6	5 7/8"	23 3/4" x 23 3/4"
	ERM5 2408	8	7 7/8"	23 3/4" x 23 3/4"
	ERM5 2410	10	9 7/8"	23 3/4" x 23 3/4"
	ERM5 2412	12	11 7/8"	23 3/4" x 23 3/4"
	ERM5 2414	14	13 7/8"	23 3/4" x 23 3/4"
	ERM5 2416	16	15 7/8"	23 3/4" x 23 3/4"

Finish	
<input type="checkbox"/> /W White (Default)	<input type="checkbox"/> /C Custom (Please Specify)



Schedule type: _____

Job: _____

Architect: _____

Engineer: _____

Contractor: _____

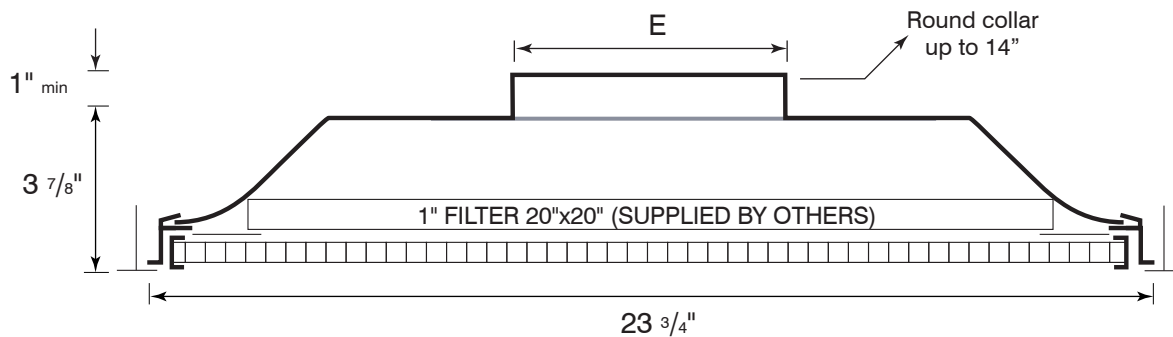
Aluminum Egg Crate Filter Return with Steel Back Panel Hinged face

- Material:** Stamped heavy gauge steel back panels with reinforcing corners.
- Grid core:** Aluminum grid 1/2" x 1/2" x 1/2" in hinged extruded aluminum U frame swings in and out of fixed frame for access to 20" x 20" filter, by others.
- Finish:** Powder paint coating - white.
- Safety:** Seismic tabs.
- Mounting:** T-bar Lay-in ceiling.



ERMF

SUBMITTAL SHEET



Finish	
<input type="checkbox"/> /W White (Default)	<input type="checkbox"/> /C Custom (Please Specify)



✓	Model #	Duct Size	E	Face Dim
	ERMF 2406	6	5 7/8"	23 3/4" x 23 3/4"
	ERMF 2408	8	7 7/8"	23 3/4" x 23 3/4"
	ERMF 2410	10	9 7/8"	23 3/4" x 23 3/4"
	ERMF 2412	12	11 7/8"	23 3/4" x 23 3/4"
	ERMF 2414	14	13 7/8"	23 3/4" x 23 3/4"

Schedule type: _____

Job: _____

Architect: _____

Engineer: _____

Contractor: _____

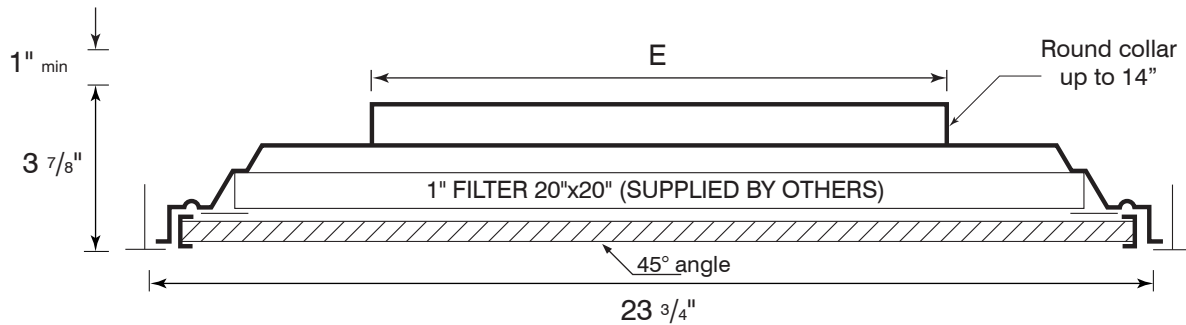
SUBMITTAL SHEET

Aluminum Egg Crate Filter Return with Steel Back Panel - Hinged face 45° Angled Eggcrate

- Material:** Stamped heavy gauge steel back panels with reinforcing corners.
Aluminum grid 1/2" x 1/2" x 1/2" in hinged extruded aluminum U frame swings in and out of fixed frame for access to 20" x 20" filter, by others.
- Grid core:** 45° Angled Eggcrate Core.
- Safety:** Seismic tabs.
- Finish:** Powder paint coating - white.
- Mounting:** T-bar Lay-in ceiling.



ERMF5



Finish	
<input type="checkbox"/> /W White (Default)	<input type="checkbox"/> /C Custom (Please Specify) _____



✓	Model #	Duct Size	E	Face Dim
	ERMF5 2406	6	5 7/8"	23 3/4" x 23 3/4"
	ERMF5 2408	8	7 7/8"	23 3/4" x 23 3/4"
	ERMF5 2410	10	9 7/8"	23 3/4" x 23 3/4"
	ERMF5 2412	12	11 7/8"	23 3/4" x 23 3/4"
	ERMF5 2414	14	13 7/8"	23 3/4" x 23 3/4"

Schedule type: _____

Job: _____

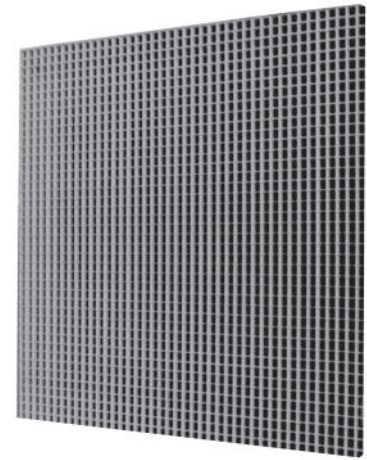
Architect: _____

Engineer: _____

Contractor: _____

Egg Crate Return Grille - Core Only

- Material:** All aluminum.
Aluminum grid $\frac{1}{2}" \times \frac{1}{2}" \times \frac{1}{2}"$.
- Grid core:** Custom face dimensions available up to 48" x 24".
- Finish:** Powder paint coating - white.
- Mounting:** T-bar Lay-in ceiling.



ERN
(Aluminum Grid Core)

SUBMITTAL SHEET



✓	Model Listed Size	Face Dim. A x B
	ERN 1212	11 $\frac{3}{4}" \times 11 \frac{3}{4}"$
	ERN 2412	23 $\frac{3}{4}" \times 11 \frac{3}{4}"$
	ERN 2424	23 $\frac{3}{4}" \times 23 \frac{3}{4}"$
	ERN 4824	47 $\frac{3}{4}" \times 23 \frac{3}{4}"$
	ERN $\frac{\quad}{\quad} \times \frac{\quad}{\quad}$ A (Length) B (Width) Max Size 48" x 24"	A - $\frac{1}{4}"$ x B - $\frac{1}{4}"$

Finish		
<input type="checkbox"/> /W White (Default)	<input type="checkbox"/> /M Mill	<input type="checkbox"/> /C Custom (Please Specify) _____



Schedule type: _____

Job: _____

Architect: _____

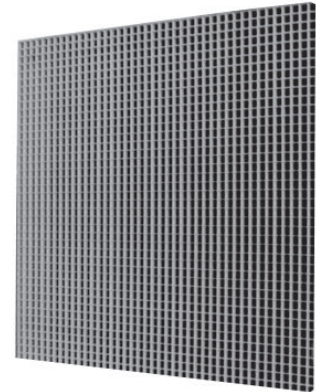
Engineer: _____

Contractor: _____

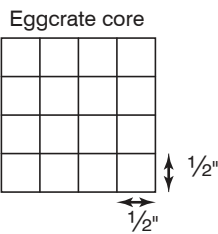
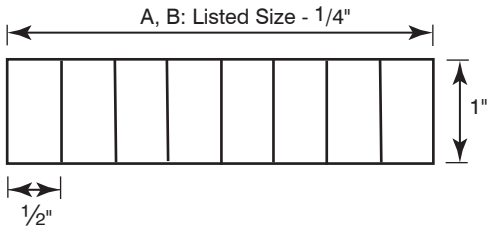
SUBMITTAL SHEET

Eggcrate Return Grille - Core Only

Material: All aluminum.
Mounting: Lay-in T-bar ceiling.
Grid cores: ERN1: 1/2" X 1/2" X 1".
 ERN3: 1" X 1" X 1".
 ERN5: 1/2" X 1/2" X 1/2".



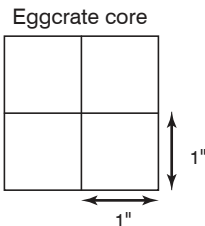
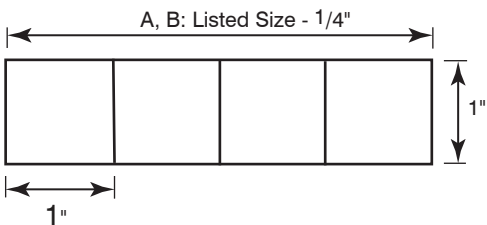
ERN1



ERN1 (Aluminum Grid Core)

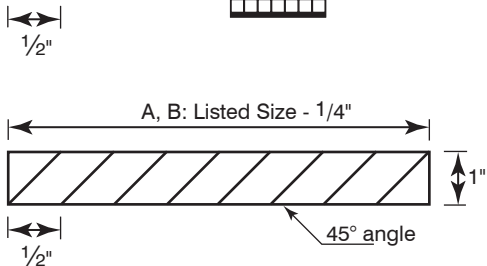
	ERN	Listed Size	Face Dim. A x B
<input checked="" type="checkbox"/>	1 3 5		
		1212	11 3/4" x 11 3/4"
		2406	23 3/4" x 5 3/4"
		2408	23 3/4" x 7 3/4"
		2412	23 3/4" x 11 3/4"
		2424	23 3/4" x 23 3/4"
		4806	47 3/4" x 5 3/4"
		4808	47 3/4" x 7 3/4"
		4812	47 3/4" x 11 3/4"
		4824	47 3/4" x 23 3/4"
		Custom Dim.	A - 1/4" x B - 1/4"
		X	
		A (Length) B (Width) (please specify) Max Size 48" x 24"	

ERN3

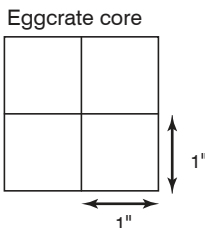


ERN5

Horizontal Air Flow (Standard)



Vertical Air Flow



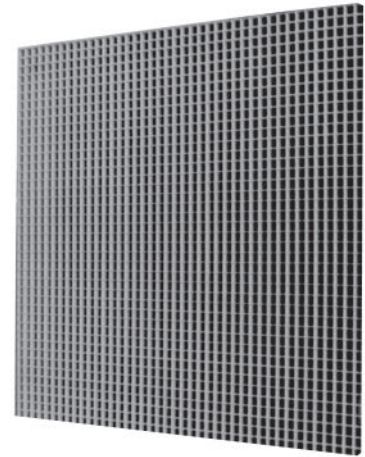
Finish		
<input type="checkbox"/> /W White (Default)	<input type="checkbox"/> /M Mill	<input type="checkbox"/> /C Custom (Please Specify)



Schedule type: _____
 Job: _____
 Architect: _____
 Engineer: _____
 Contractor: _____

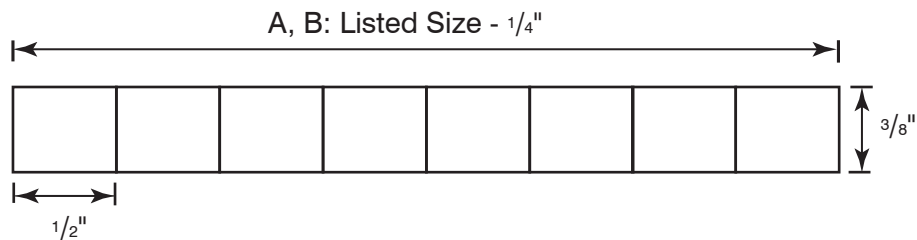
Eggcrate Return Grille - Core Only

- Material:** Polystyrene-based material.
Grid core: Plastic $\frac{1}{2}$ " x $\frac{1}{2}$ " x $\frac{3}{8}$ ".
Finish: White color.
Mounting: T-bar Lay-in ceiling.



ERN-P
(Plastic Grid Core)

SUBMITTAL SHEET

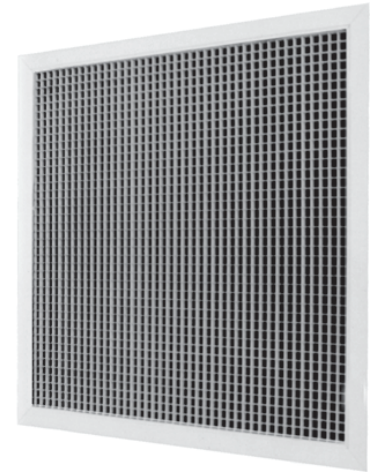


✓	Model Listed Size	Face Dim. A x B
	ERN-P 1212	11 $\frac{3}{4}$ " x 11 $\frac{3}{4}$ "
	ERN-P 2412	23 $\frac{3}{4}$ " x 11 $\frac{3}{4}$ "
	ERN-P 2424	23 $\frac{3}{4}$ " x 23 $\frac{3}{4}$ "
	ERN-P 4824	47 $\frac{3}{4}$ " x 23 $\frac{3}{4}$ "
	ERN-P $\frac{\quad}{\quad}$ x $\frac{\quad}{\quad}$ A (Length) B (Width) Max Size 48" x 24"	A - $\frac{1}{4}$ " x B - $\frac{1}{4}$ "

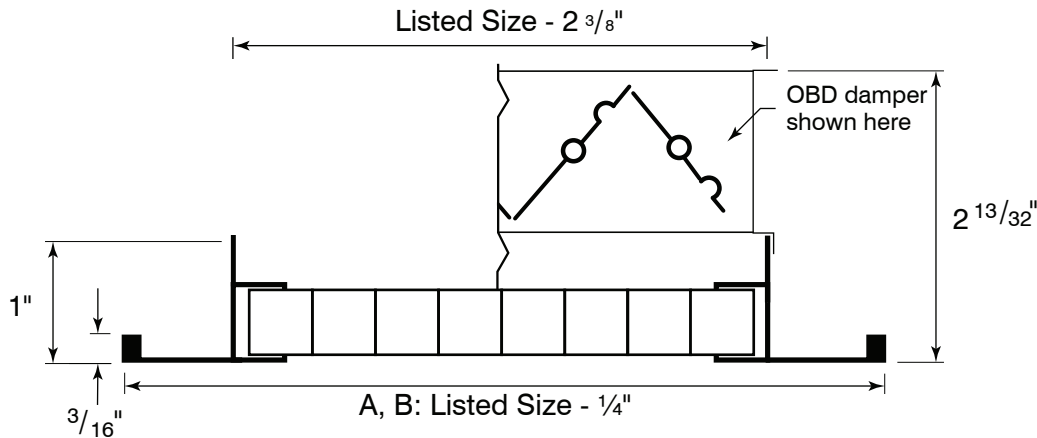
Schedule type: _____
Job: _____
Architect: _____
Engineer: _____
Contractor: _____

Egg Crate Return Grille, T-Bar Mount

- Material:** All aluminium construction.
- Mounting:** Lay-in T-bar ceiling.
No mounting holes. 1 1/4" Frame.
- Grid core:** Aluminum 1/2" x 1/2" x 1/2".

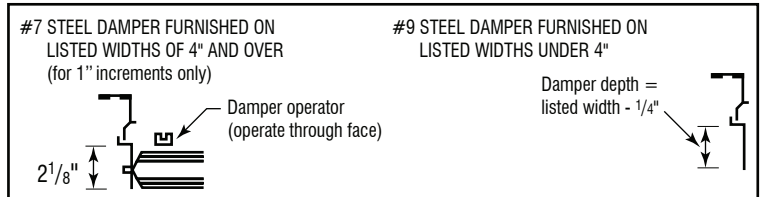


ERT / ERT7



✓	Model #	Face Dim. A x B	Neck
	ERT 1212	11 3/4" x 11 3/4"	9 5/8" x 9 5/8"
	ERT 2412	23 3/4" x 11 3/4"	21 5/8" x 9 5/8"
	ERT 2424	23 3/4" x 23 3/4"	21 5/8" x 21 5/8"
	ERT 4812	47 3/4" x 11 3/4"	46 5/8" x 9 5/8"
	ERT 4824	47 3/4" x 23 3/4"	46 5/8" x 21 5/8"
	ERT7 1212	11 3/4" x 11 3/4"	9 5/8" x 9 5/8"
	ERT7 2412	23 3/4" x 11 3/4"	21 5/8" x 9 5/8"
	ERT7 2424	23 3/4" x 23 3/4"	21 5/8" x 21 5/8"
	ERT7 4812	47 3/4" x 11 3/4"	46 5/8" x 9 5/8"
	ERT7 4824	47 3/4" x 23 3/4"	46 5/8" x 21 5/8"

Custom dimensions available upon request.



Panel Option for T-bar lay-in Ceiling

W	Steel (WxH)	Aluminum (WxH)
	<input type="checkbox"/> -X1212	<input type="checkbox"/> -Y1212
	<input type="checkbox"/> -X2412	<input type="checkbox"/> -Y2412
	<input type="checkbox"/> -X2424	<input type="checkbox"/> -Y2424
	<input type="checkbox"/> -X4812	<input type="checkbox"/> -Y4812
	<input type="checkbox"/> -X4824	<input type="checkbox"/> -Y4824

No fastening options available

Finish	
<input type="checkbox"/> /W White (Default)	<input type="checkbox"/> /C Custom (Please Specify)



Schedule type: _____

Job: _____

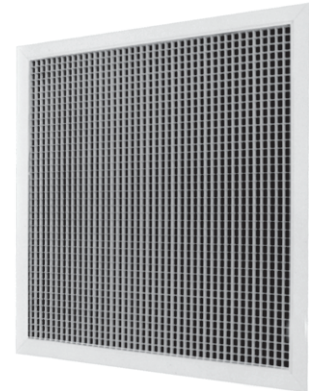
Architect: _____

Engineer: _____

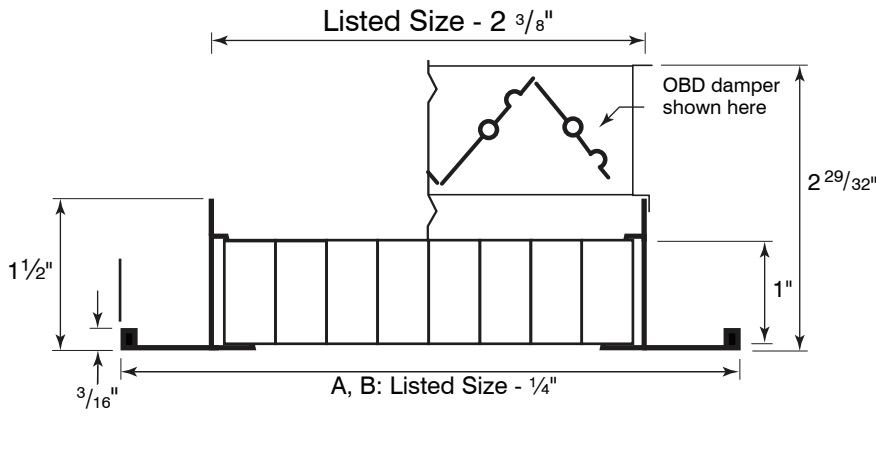
Contractor: _____

Egg Crate Return Grille, T-Bar Mount 1" thick core

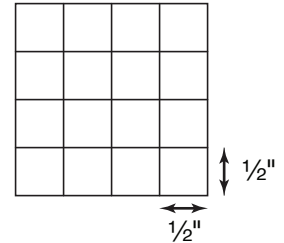
- Material:** All aluminium construction.
Mounting: Lay-in T-bar ceiling.
 No mounting holes, 1 1/4" Frame.
Grid core: Aluminum 1/2" x 1/2" x 1".



SUBMITTAL SHEET

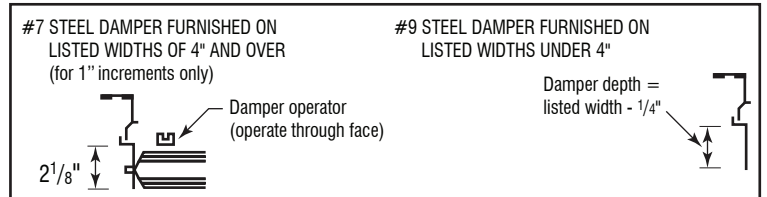

ERT1 / ERT17

Eggcrate core



✓	Model #	Face Dim. A x B	Neck
	ERT1 1212	11 3/4" x 11 3/4"	9 5/8" x 9 5/8"
	ERT1 2412	23 3/4" x 11 3/4"	21 5/8" x 9 5/8"
	ERT1 2424	23 3/4" x 23 3/4"	21 5/8" x 21 5/8"
	ERT1 4812	47 3/4" x 11 3/4"	46 5/8" x 9 5/8"
	ERT1 4824	47 3/4" x 23 3/4"	46 5/8" x 21 5/8"
	ERT17 1212	11 3/4" x 11 3/4"	9 5/8" x 9 5/8"
	ERT17 2412	23 3/4" x 11 3/4"	21 5/8" x 9 5/8"
	ERT17 2424	23 3/4" x 23 3/4"	21 5/8" x 21 5/8"
	ERT17 4812	47 3/4" x 11 3/4"	46 5/8" x 9 5/8"
	ERT17 4824	47 3/4" x 23 3/4"	46 5/8" x 21 5/8"

Custom dimensions available upon request.



Panel Option for T-bar lay-in Ceiling

W	Steel (WxH)		Aluminum (WxH)	
	□	□	□	□
H	□	-X1212	□	-Y1212
	□	-X2412	□	-Y2412
	□	-X2424	□	-Y2424
	□	-X4812	□	-Y4812
	□	-X4824	□	-Y4824

No fastening options available

Finish	
<input type="checkbox"/> /W White (Default)	<input type="checkbox"/> /C Custom (Please Specify)



Schedule type: _____

Job: _____

Architect: _____

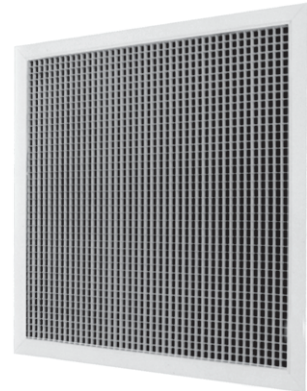
Engineer: _____

Contractor: _____

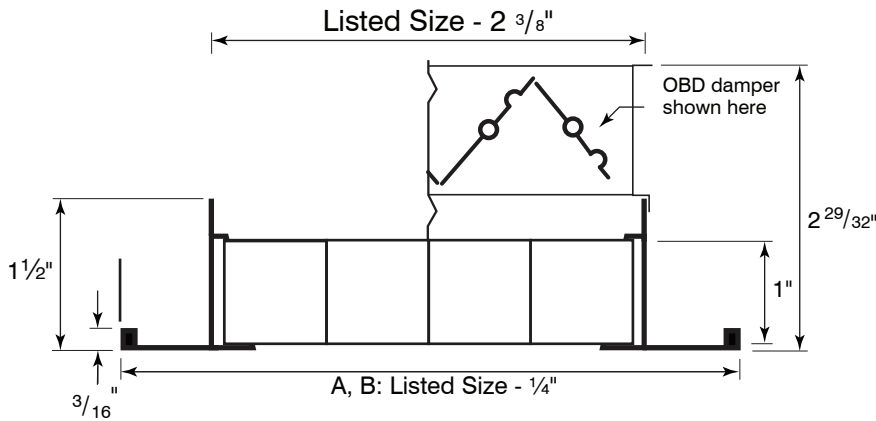
SUBMITTAL SHEET

Egg Crate Return Grille T-Bar Mount, 1" Square Cell Size

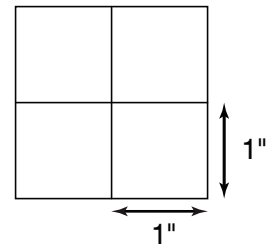
Material: Stamped heavy gauge steel.
Finish: Powder paint coating - white.
Air Pattern: Fixed.
Mounting: Lay-in T-bar ceiling.



ERT3 / ERT37



Eggcrate core



✓	Model #	Face Dim. A x B	Neck
	ERT3 1212	11 ³ / ₄ " x 11 ³ / ₄ "	9 ⁵ / ₈ " x 9 ⁵ / ₈ "
	ERT3 2412	23 ³ / ₄ " x 11 ³ / ₄ "	21 ⁵ / ₈ " x 9 ⁵ / ₈ "
	ERT3 2424	23 ³ / ₄ " x 23 ³ / ₄ "	21 ⁵ / ₈ " x 21 ⁵ / ₈ "
	ERT3 812	47 ³ / ₄ " x 11 ³ / ₄ "	46 ⁵ / ₈ " x 9 ⁵ / ₈ "
	ERT3 4824	47 ³ / ₄ " x 23 ³ / ₄ "	46 ⁵ / ₈ " x 21 ⁵ / ₈ "
	ERT37 1212	11 ³ / ₄ " x 11 ³ / ₄ "	9 ⁵ / ₈ " x 9 ⁵ / ₈ "
	ERT37 2412	23 ³ / ₄ " x 11 ³ / ₄ "	21 ⁵ / ₈ " x 9 ⁵ / ₈ "
	ERT37 2424	23 ³ / ₄ " x 23 ³ / ₄ "	21 ⁵ / ₈ " x 21 ⁵ / ₈ "
	ERT37 4812	47 ³ / ₄ " x 11 ³ / ₄ "	46 ⁵ / ₈ " x 9 ⁵ / ₈ "
	ERT37 4824	47 ³ / ₄ " x 23 ³ / ₄ "	46 ⁵ / ₈ " x 21 ⁵ / ₈ "

Custom dimensions available upon request.

#7 STEEL DAMPER FURNISHED ON LISTED WIDTHS OF 4" AND OVER (for 1" increments only)

2 1/8" Damper operator (operate through face)

#9 STEEL DAMPER FURNISHED ON LISTED WIDTHS UNDER 4"

Damper depth = listed width - 1/4"

Panel Option for T-bar lay-in Ceiling

	Steel (WxH)	Aluminum (WxH)
 No fastening options available	<input type="checkbox"/> -X2412	<input type="checkbox"/> -Y2412
	<input type="checkbox"/> -X2424	<input type="checkbox"/> -Y2424
	<input type="checkbox"/> -X2448	<input type="checkbox"/> -Y2448
	<input type="checkbox"/> -X4824	<input type="checkbox"/> -Y4824
	<input type="checkbox"/> -X2020	<input type="checkbox"/> -Y2020

Finish	
<input type="checkbox"/> /W White (Default)	<input type="checkbox"/> /C Custom (Please Specify)



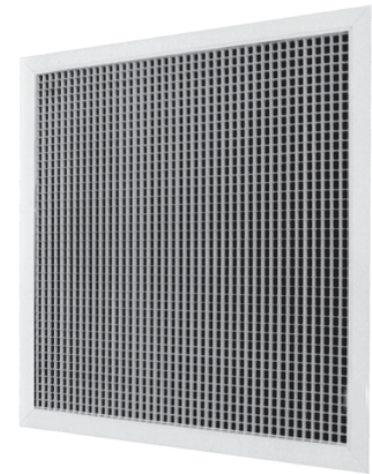
Schedule type: _____

Job: _____

Architect: _____

Engineer: _____

Contractor: _____

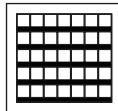


Egg Crate Return Grille, T-Bar Mount 45° Angled Eggcrate

- Material:** All aluminium construction.
- Mounting:** Lay-in T-bar ceiling.
No mounting holes. 1 1/4" Frame
- Grid core:** Aluminium 1/2" x 1/2" x 1/2"
45° Angled Eggcrate Core

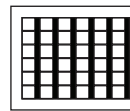
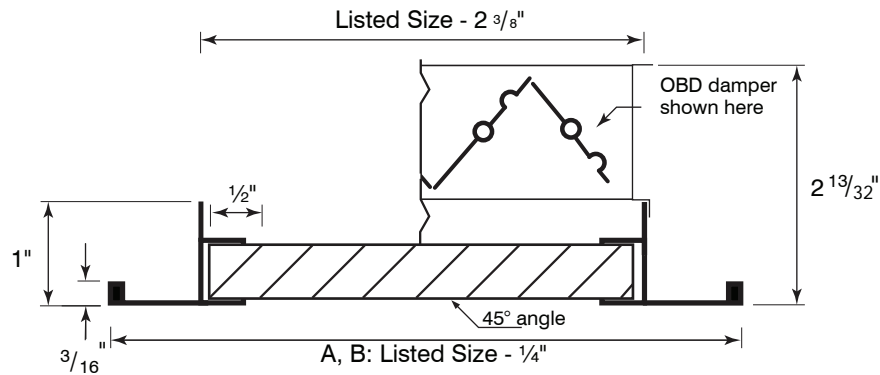
Horizontal Air Flow (Standard)

- ERT5**
- ERT57** with OBD



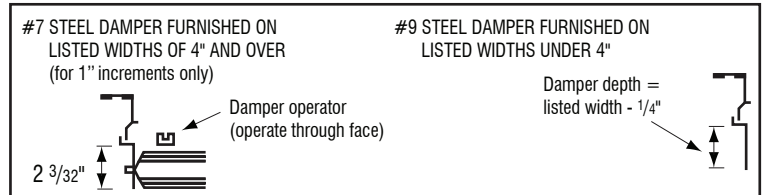
Vertical Face Bars

- ERT5-V**
- ERT57-V** with OBD


ERT5 / ERT57


✓	Model #	Face Dim. A x B	Neck
	ERT5 1212	11 3/4" x 11 3/4"	9 5/8" x 9 5/8"
	ERT5 2412	23 3/4" x 11 3/4"	21 5/8" x 9 5/8"
	ERT5 2424	23 3/4" x 23 3/4"	21 5/8" x 21 5/8"
	ERT5 4812	47 3/4" x 11 3/4"	46 5/8" x 9 5/8"
	ERT5 4824	47 3/4" x 23 3/4"	46 5/8" x 21 5/8"
	ERT57 1212	11 3/4" x 11 3/4"	9 5/8" x 9 5/8"
	ERT57 2412	23 3/4" x 11 3/4"	21 5/8" x 9 5/8"
	ERT57 2424	23 3/4" x 23 3/4"	21 5/8" x 21 5/8"
	ERT57 4812	47 3/4" x 11 3/4"	46 5/8" x 9 5/8"
	ERT57 4824	47 3/4" x 23 3/4"	46 5/8" x 21 5/8"

Custom dimensions available upon request.



Panel Option for T-bar lay-in Ceiling

W	Steel (WxH)	Aluminum (WxH)
	<input type="checkbox"/> -X1212	<input type="checkbox"/> -Y1212
	<input type="checkbox"/> -X2412	<input type="checkbox"/> -Y2412
	<input type="checkbox"/> -X2424	<input type="checkbox"/> -Y2424
	<input type="checkbox"/> -X4812	<input type="checkbox"/> -Y4812
	<input type="checkbox"/> -X4824	<input type="checkbox"/> -Y4824
	<input type="checkbox"/> -X4824	<input type="checkbox"/> -Y4824

No fastening options available

Finish

- /W White (Default)
- /C Custom (Please Specify)



Schedule type: _____

Job: _____

Architect: _____

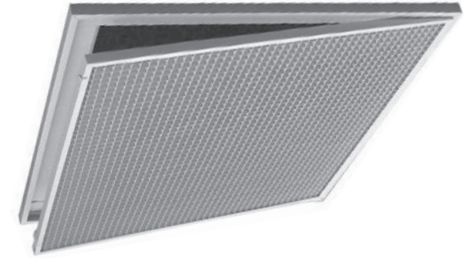
Engineer: _____

Contractor: _____

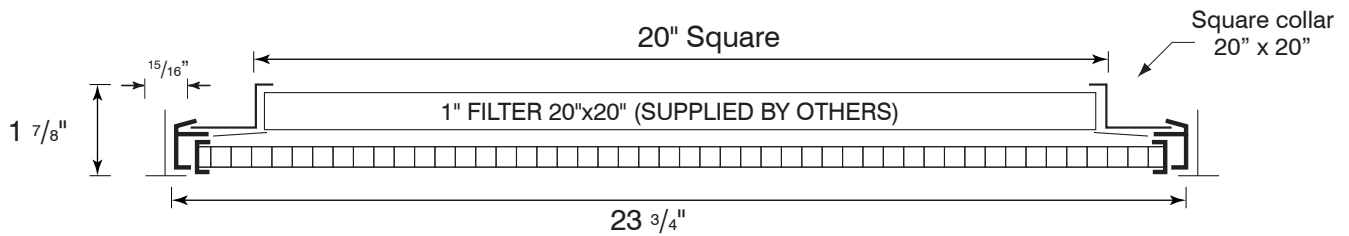
SUBMITTAL SHEET

Aluminum Egg Crate Filter Return with 20" x 20" Filter Frame Hinged face - Steel Back

- Material:** Steel filter frame will accept 20"x20" standard 1" filter. Aluminum egg crate grid 1/2"x1/2"x1/2" in hinged extruded aluminum U frame, swings in and out of fixed frame for access to 20" x 20" filter, by others.
- Finish:** Powder paint coating - white.
- Mounting:** T-bar Lay-in ceiling.



ERTF



Mounting	
<input checked="" type="checkbox"/> -NT	Narrow T-bar

Finish	
<input type="checkbox"/> /W	White (Default)
<input type="checkbox"/> /C	Custom (Please Specify)



Schedule type: _____

Job: _____

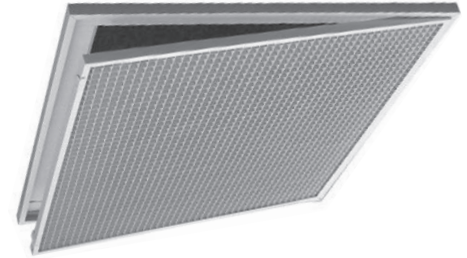
Architect: _____

Engineer: _____

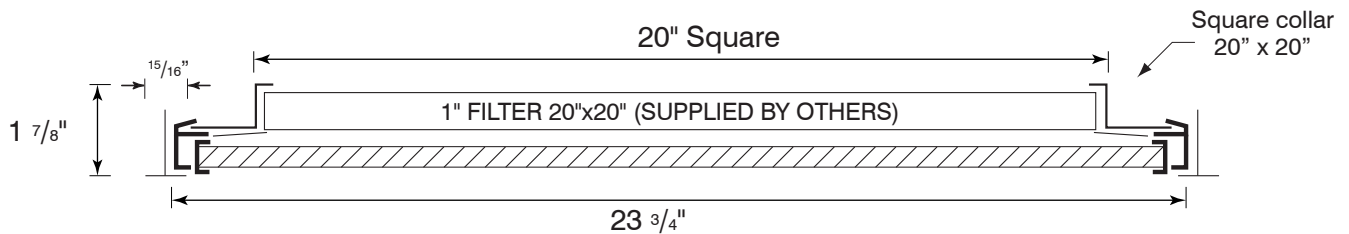
Contractor: _____


Aluminum Egg Crate Filter Return with 20" x 20" Filter Frame Hinged face - Steel Back 45° Angled Egg Crate

- Material:** Steel filter frame will accept 20"x20" standard 1" filter. Aluminum egg crate grid 1/2" x 1/2" x 1/2" in hinged extruded aluminum U frame, swings in and out of fixed frame for access to 20" x 20" filter, by others.
- Grid core:** 45° Angled egg crate Core
- Finish:** Powder paint coating - white.
- Mounting:** T-bar Lay-in ceiling.


ERTF5

SUBMITTAL SHEET



Mounting	
<input type="checkbox"/> -NT	Narrow T-bar
	

Finish	
<input type="checkbox"/> /W	White (Default)
<input type="checkbox"/> /C	Custom (Please Specify)



Schedule type: _____

Job: _____

Architect: _____

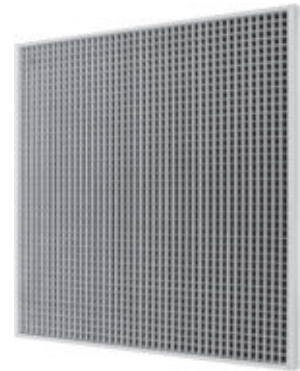
Engineer: _____

Contractor: _____

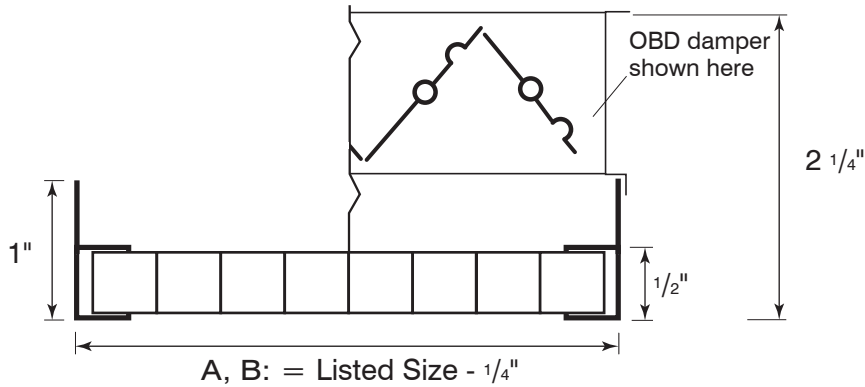
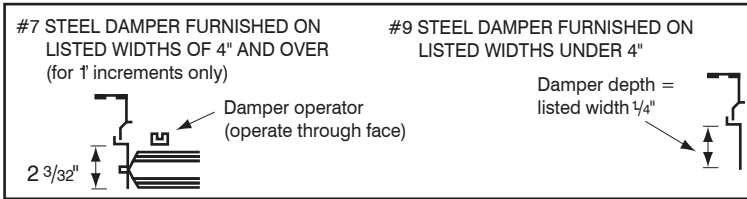
SUBMITTAL SHEET

Egg Crate Return Grille with "U" Frame

- Material:** All aluminium construction.
Mounting: Lay-in T-bar ceiling.
 No mounting holes.
Grid core: Aluminum 1/2" x 1/2" x 1/2".



ERU / ERU7
(ERU 2424 shown here)



✓	Model #	Face Dim. A x B	Neck
	ERU 1212	11 3/4" x 11 3/4"	12" x 12"
	ERU 2412	23 3/4" x 11 3/4"	24" x 12"
	ERU 2424	23 3/4" x 23 3/4"	24" x 24"
	ERU 4812	47 3/4" x 11 3/4"	48" x 12"
	ERU 4824	47 3/4" x 23 3/4"	48" x 24"
	ERU7 1212	11 3/4" x 11 3/4"	12" x 12"
	ERU7 2412	23 3/4" x 11 3/4"	24" x 12"
	ERU7 2424	23 3/4" x 23 3/4"	24" x 24"
	ERU7 4812	47 3/4" x 11 3/4"	48" x 12"
	ERU7 4824	47 3/4" x 23 3/4"	48" x 24"

Custom dimensions available upon request.

Finish	
<input type="checkbox"/> /W White (Default)	<input type="checkbox"/> /C Custom (Please Specify)



Schedule type: _____

Job: _____

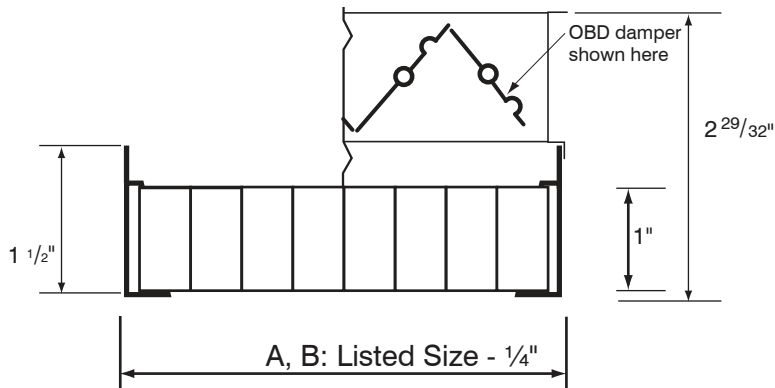
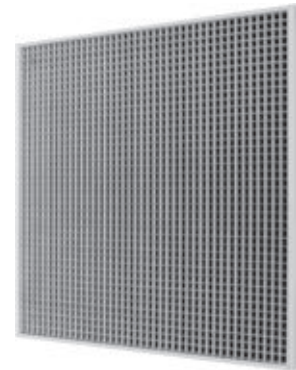
Architect: _____

Engineer: _____

Contractor: _____

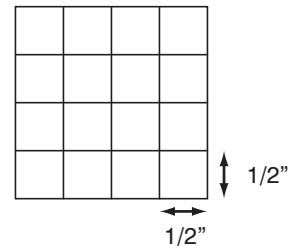
Egg Crate Return Grille with "U" Frame, 1" thick core

- Material:** All aluminium construction.
T-bar lay-in.
- Mounting:** No mounting holes.
- Grid core:** Aluminum 1/2" x 1/2" x 1".



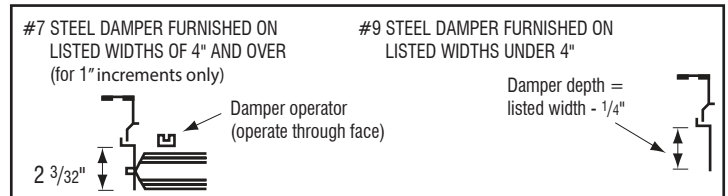
ERU1 / ERU17

Egg Crate core



✓	Model #	Face Dim. A x B	Neck
	ERU1 1212	11 ³ / ₄ " x 11 ³ / ₄ "	12" x 12"
	ERU1 2412	23 ³ / ₄ " x 11 ³ / ₄ "	24" x 12"
	ERU1 2424	23 ³ / ₄ " x 23 ³ / ₄ "	24" x 24"
	ERU1 4812	47 ³ / ₄ " x 11 ³ / ₄ "	48" x 12"
	ERU1 4824	47 ³ / ₄ " x 23 ³ / ₄ "	48" x 24"
	ERU17 1212	11 ³ / ₄ " x 11 ³ / ₄ "	12" x 12"
	ERU17 2412	23 ³ / ₄ " x 11 ³ / ₄ "	24" x 12"
	ERU17 2424	23 ³ / ₄ " x 23 ³ / ₄ "	24" x 24"
	ERU17 4812	47 ³ / ₄ " x 11 ³ / ₄ "	48" x 12"
	ERU17 4824	47 ³ / ₄ " x 23 ³ / ₄ "	48" x 24"

Custom dimensions available upon request.



Panel Option for T-bar lay-in Ceiling

W	H	Steel (WxH)	Aluminum (WxH)
<input type="checkbox"/>	<input type="checkbox"/>	-X2412	-Y2412
<input type="checkbox"/>	<input type="checkbox"/>	-X2424	-Y2424
<input type="checkbox"/>	<input type="checkbox"/>	-X2448	-Y2448
<input type="checkbox"/>	<input type="checkbox"/>	-X4824	-Y4824
<input type="checkbox"/>	<input type="checkbox"/>	-X2020	-Y2020

No fastening options available

Finish	
<input type="checkbox"/> /W White (Default)	<input type="checkbox"/> /C Custom (Please Specify)



Schedule type: _____

Job: _____

Architect: _____

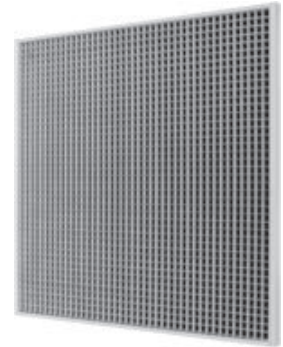
Engineer: _____

Contractor: _____

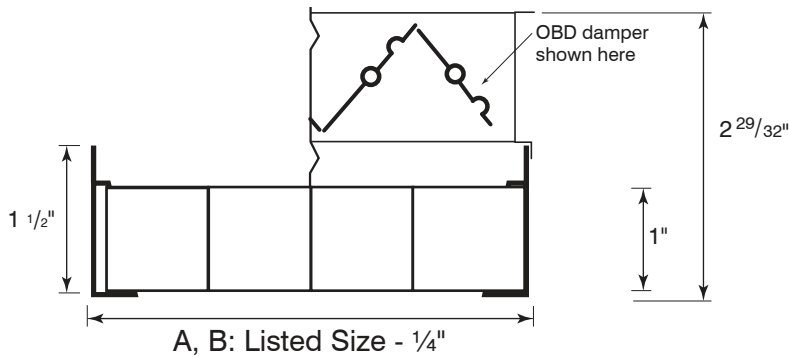
SUBMITTAL SHEET

Egg Crate Return Grille with "U" Frame 1" square cell size

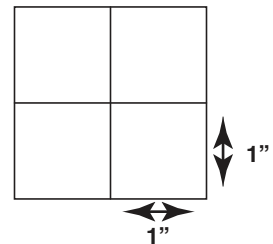
- Material:** All aluminium construction.
Mounting: T-bar lay-in.
 No mounting holes.
Grid core: Aluminum 1" x 1" x 1".



ERU3 / ERU37
(ERU 2424 shown here)

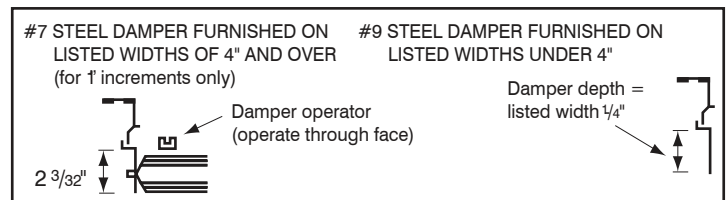


Egg Crate core



✓	Model #	Face Dim. A x B	Neck
	ERU3 1212	11 ³ / ₄ " x 11 ³ / ₄ "	12" x 12"
	ERU3 2412	23 ³ / ₄ " x 11 ³ / ₄ "	24" x 12"
	ERU3 2424	23 ³ / ₄ " x 23 ³ / ₄ "	24" x 24"
	ERU3 4812	47 ³ / ₄ " x 11 ³ / ₄ "	48" x 12"
	ERU3 4824	47 ³ / ₄ " x 23 ³ / ₄ "	48" x 24"
	ERU37 1212	11 ³ / ₄ " x 11 ³ / ₄ "	12" x 12"
	ERU37 2412	23 ³ / ₄ " x 11 ³ / ₄ "	24" x 12"
	ERU37 2424	23 ³ / ₄ " x 23 ³ / ₄ "	24" x 24"
	ERU37 4812	47 ³ / ₄ " x 11 ³ / ₄ "	48" x 12"
	ERU37 4824	47 ³ / ₄ " x 23 ³ / ₄ "	48" x 24"

Custom dimensions available upon request.



Panel Option for T-bar lay-in Ceiling

W	Steel (WxH)	Aluminum (WxH)
	<input type="checkbox"/> -X1212	<input type="checkbox"/> -Y1212
	<input type="checkbox"/> -X2412	<input type="checkbox"/> -Y2412
	<input type="checkbox"/> -X2424	<input type="checkbox"/> -Y2424
	<input type="checkbox"/> -X4812	<input type="checkbox"/> -Y4812
	<input type="checkbox"/> -X4824	<input type="checkbox"/> -Y4824
	No fastening options available	

Finish	
<input type="checkbox"/> /W White (Default)	<input type="checkbox"/> /C Custom (Please Specify)



Schedule type: _____

Job: _____

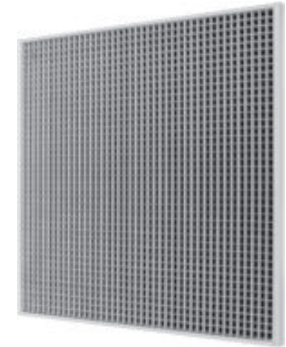
Architect: _____

Engineer: _____

Contractor: _____

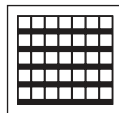
Egg Crate Return Grille with "U" Frame 45° Angled Eggcrate

- Material:** All aluminium construction.
- Mounting:** T-bar lay-in.
No mounting holes.
- Grid core:** Aluminum 1/2" x 1/2" x 1/2".
45° Angled Egg Crate Core



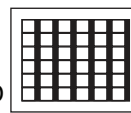
Horizontal Air Flow (Standard)

- ERU5
- ERU57 with OBD

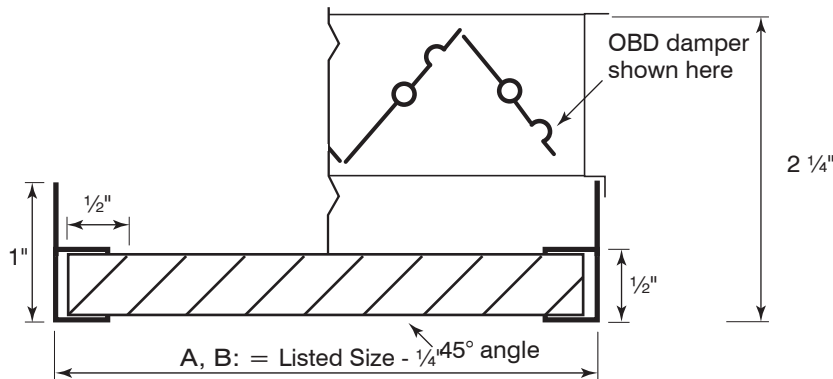


Vertical Face Bars

- ERU5-V
- ERU57-V with OBD



ERU5 / ERU57
(ERU5 2424 shown here)



✓	Model #	Face Dim. A x B	Neck
	ERU5 1212	11 3/4" x 11 3/4"	12" x 12"
	ERU5 2412	23 3/4" x 11 3/4"	24" x 12"
	ERU5 2424	23 3/4" x 23 3/4"	24" x 24"
	ERU5 4812	47 3/4" x 11 3/4"	48" x 12"
	ERU5 4824	47 3/4" x 23 3/4"	48" x 24"
	ERU57 1212	11 3/4" x 11 3/4"	12" x 12"
	ERU57 2412	23 3/4" x 11 3/4"	24" x 12"
	ERU57 2424	23 3/4" x 23 3/4"	24" x 24"
	ERU57 4812	47 3/4" x 11 3/4"	48" x 12"
	ERU57 4824	47 3/4" x 23 3/4"	48" x 24"

Custom dimensions available upon request.

#7 STEEL DAMPER FURNISHED ON LISTED WIDTHS OF 4" AND OVER (for 1" increments only)

2 3/32"

#9 STEEL DAMPER FURNISHED ON LISTED WIDTHS UNDER 4"

Damper depth = listed width - 1/4"

Damper operator (operate through face)

Finish	
<input type="checkbox"/> /W White (default)	<input type="checkbox"/> /C Custom (please specify) _____



Schedule type: _____

Job: _____

Architect: _____

Engineer: _____

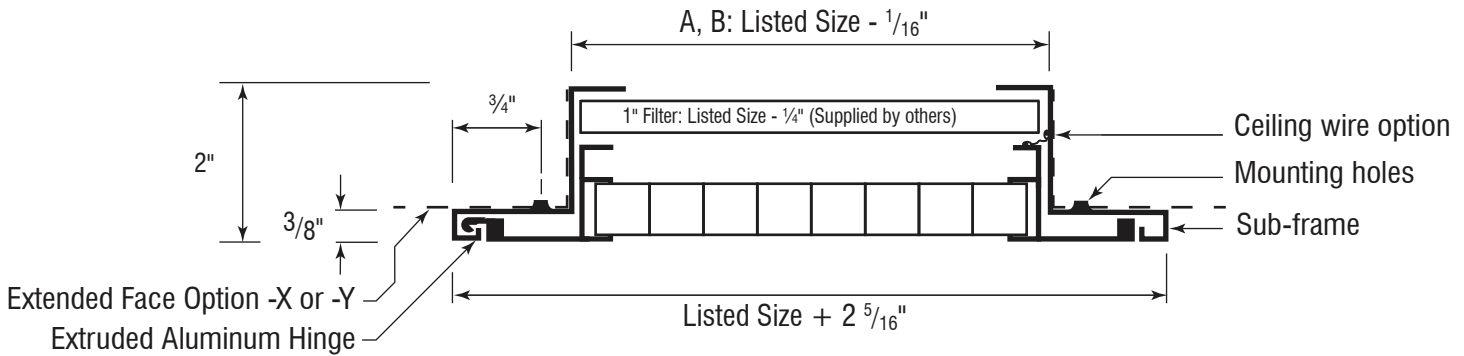
Contractor: _____

Eggcrate Filter Return Grille for Surface Mount

- Material:** All aluminium construction
Hinged extrusion on one end, easy pry-open or push-close clip
- Mounting:** Surface mounting
Countersunk mounting holes on sub-frame.
- Grid core:** Aluminum 1/2" x 1/2" x 1/2"
- Filter:** 1" filter: Listed size - 1/4" (supplied by others)



FERE



Filter Options				
-F0 No Filter <small>N/A with -C</small>	-F0.5 0.5" Filter	-F1 1" Filter	-F2 2" Filter	-F4 4" Filter

Options		
-CW Security Ceiling Wire	-DS Debris (Bird) Screen	-IS Insect Screen


Size limits	Width A		Height B	
	in	mm	in	mm
Minimum	4	102	4	102
Maximum	48	1219	48	1219

Panel Option for T-bar lay-in Ceiling		
	Steel (WxH)	Aluminum (WxH)
	<input type="checkbox"/> -X1212	<input type="checkbox"/> -Y1212
	<input type="checkbox"/> -X2412	<input type="checkbox"/> -Y2412
	<input type="checkbox"/> -X2424	<input type="checkbox"/> -Y2424
	<input type="checkbox"/> -X4824	<input type="checkbox"/> -Y4824
	<input type="checkbox"/> -X2020	<input type="checkbox"/> -Y2020

No mounting options available

Latching Options			
-C (Default) Concealed Clip Easy pry-open push-close clip <small>N/A with -C</small>	-S Screen Tabs <i>Coming Soon</i>	-TS Thumb Screw	-CS Countersunk Screw

Finish		
<input type="checkbox"/> /W White (Default)	<input type="checkbox"/> /M Mill	<input type="checkbox"/> /C Custom (Please Specify)



Schedule type: _____

Job: _____

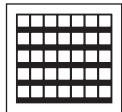
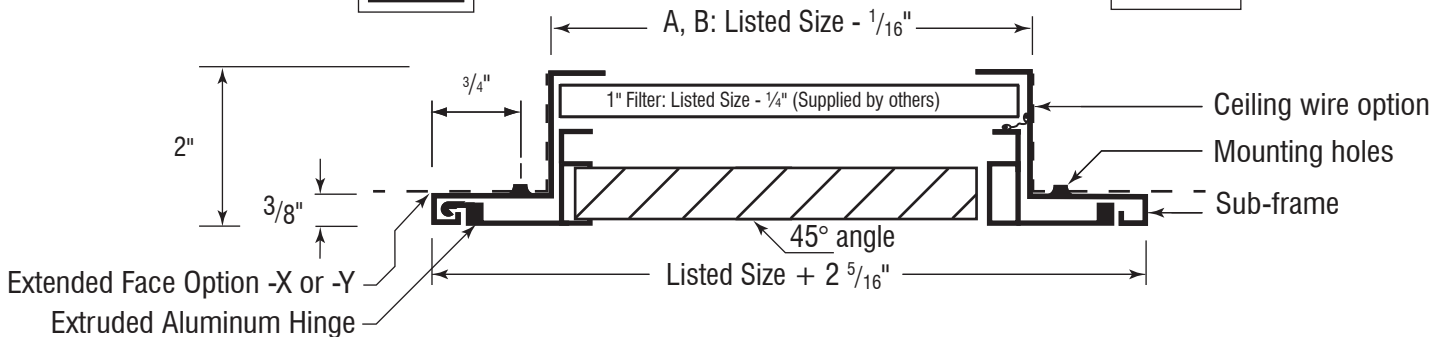
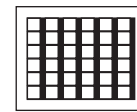
Architect: _____

Engineer: _____

Contractor: _____

Egg Crate Filter Return Grille for Surface Mount 45° Angled Egg Crate

- Material:** All aluminium construction
Hinged extrusion on one end, easy pry-open or push-close clip
- Mounting:** Surface mounting
Countersunk mounting holes on sub-frame.
- Grid core:** Aluminum 1/2" x 1/2" x 1/2" - 45° Angled Eggcrate Core
- Filter:** 1" filter: Listed size - 1/4" (supplied by others)


FERES5
Horizontal Air Flow (Standard)
 FERES5

Vertical Air Flow
 FERES5-V

Filter Options

-F0 No Filter	-F0.5 0.5" Filter	-F1 1" Filter	-F2 2" Filter	-F4 4" Filter
N/A with -C				

Options

-CW Security Ceiling Wire	-DS Debris (Bird) Screen	-IS Insect Screen
------------------------------	-----------------------------	----------------------

Size limits	Width A		Height B	
	in	mm	in	mm
Minimum	4	102	4	102
Maximum	48	1219	48	1219

Latching Options

-C (Default) Concealed Clip Easy pry-open push-close clip N/A with -C	-S Screen Tabs Coming Soon	-TS Thumb Screw	-CS Countersunk Screw
--	----------------------------------	--------------------	--------------------------

Finish

/W White (Default)	/M Mill	/C Custom (Please Specify)
-----------------------	------------	----------------------------


Panel Option for T-bar lay-in Ceiling

W	H	Steel (WxH)		Aluminum (WxH)	
		<input type="checkbox"/> -X1212	<input type="checkbox"/> -Y1212	<input type="checkbox"/> -X2412	<input type="checkbox"/> -Y2412
		<input type="checkbox"/> -X2424	<input type="checkbox"/> -Y2424	<input type="checkbox"/> -X4824	<input type="checkbox"/> -Y4824
		<input type="checkbox"/> -X2020	<input type="checkbox"/> -Y2020		
		No mounting options available			

Schedule type: _____

Job: _____

Architect: _____

Engineer: _____

Contractor: _____

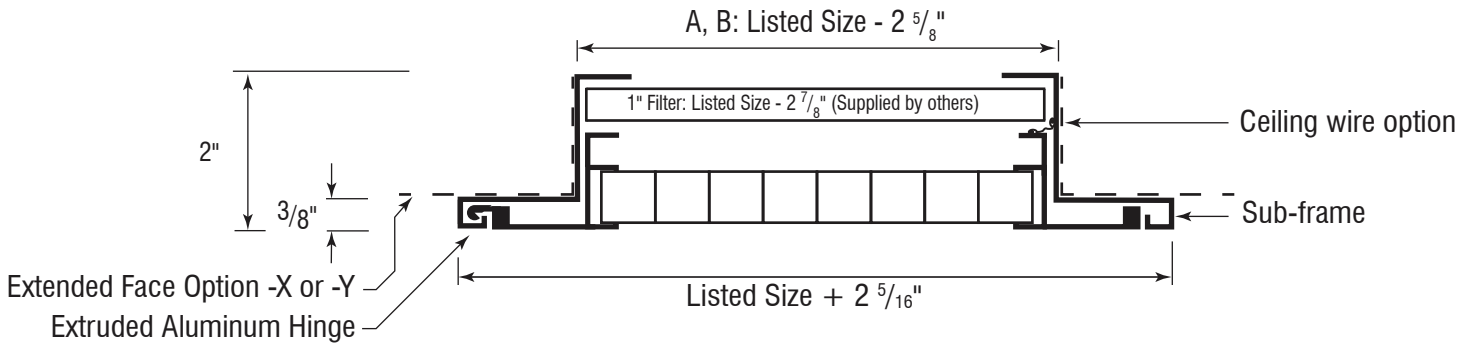
SUBMITTAL SHEET

Egg Crate Filter Return Grille for T-Bar Mount

- Material:** All aluminium construction
Hinged extrusion on one end, easy pry-open or push-close clip.
- Mounting:** Lay-in T-bar ceiling.
No mounting holes on sub-frame.
- Grid core:** Aluminum 1/2 x 1/2 x 1/2.
- Filter:** 1" filter: Listed size - 2 7/8" (supplied by others).



FERT



Filter Options				
-F0 No Filter N/A with -C	-F0.5 0.5" Filter	-F1 1" Filter	-F2 2" Filter	-F4 4" Filter

Options		
-CW Security Ceiling Wire	-DS Debris (Bird) Screen	-IS Insect Screen

Size limits	Width A		Height B	
	in	mm	in	mm
Minimum	4	102	4	102
Maximum	48	1219	48	1219

Latching Options			
-C (Default) Concealed Clip Easy pry-open push-close clip N/A with -C	-S Screen Tabs Coming Soon	-TS Thumb Screw	-CS Countersunk Screw

Finish		
<input type="checkbox"/> /W White (Default)	<input type="checkbox"/> /M Mill	<input type="checkbox"/> Custom (Please Specify)



Panel Option for T-bar lay-in Ceiling				
W	Steel (WxH)		Aluminum (WxH)	
		H		
	<input type="checkbox"/> -X1212	<input type="checkbox"/> -Y1212	<input type="checkbox"/> -X2412	<input type="checkbox"/> -Y2412
	<input type="checkbox"/> -X2424	<input type="checkbox"/> -Y2424	<input type="checkbox"/> -X4812	<input type="checkbox"/> -Y4812
	<input type="checkbox"/> -X4824	<input type="checkbox"/> -Y4824		
	No mounting options available			

Schedule type: _____

Job: _____

Architect: _____

Engineer: _____

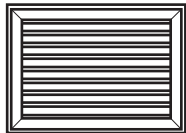
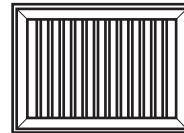
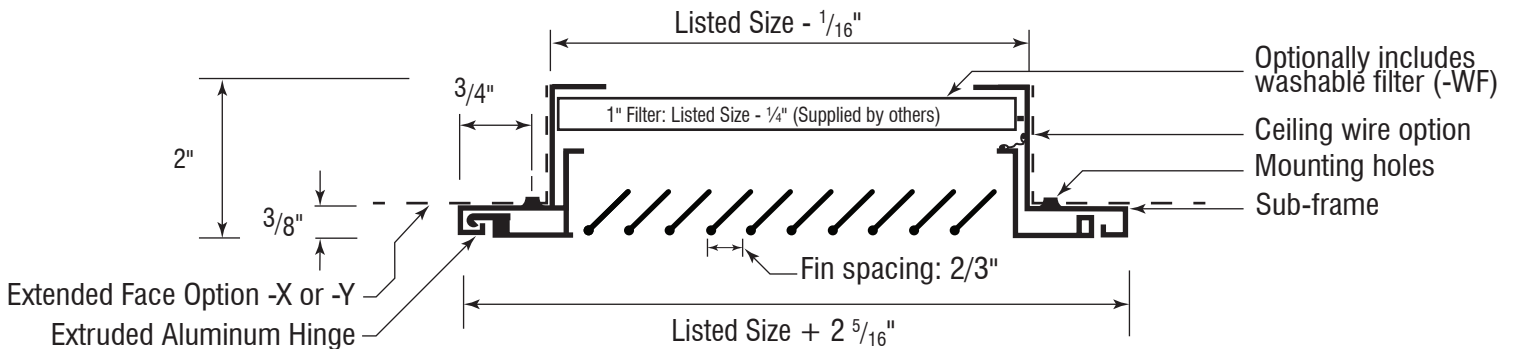
Contractor: _____

Filter Return Grille for Surface Mount

- Material:** Aluminum frame and fins
Hinged extrusion on one end, easy pry-open or push-close clip
- Mounting:** Surface mounting
Countersunk mounting holes on sub-frame.
- Grille core:** Fin spacing: 2/3"
- Filter:** Filter: 1" filter: Listed size - 1/4" (supplied by others)


FGAA

SUBMITTAL SHEET


 FGAA

 FGAA-V


Filter Options				
-F0 No Filter 	-F0.5 0.5" Filter 	-F1 1" Filter 	-F2 2" Filter 	-F4 4" Filter

Options					Fins
-CW Security Ceiling Wire 	-DS Debris (Bird) Screen 	-IS Insect Screen 	-R Removable Core Hinge removed for wall-mount application 	-WF Washable Filters 	-FB 0° deflection

Panel Option for T-bar lay-in Ceiling		
	Steel (WxH)	Aluminum (WxH)
	<input type="checkbox"/> -X1212	<input type="checkbox"/> -Y1212
	<input type="checkbox"/> -X2412	<input type="checkbox"/> -Y2412
	<input type="checkbox"/> -X2424	<input type="checkbox"/> -Y2424
	<input type="checkbox"/> -X4824	<input type="checkbox"/> -Y4824
	<input type="checkbox"/> -X2020	<input type="checkbox"/> -Y2020

No mounting options available

Latching Options			
-C (Default) Concealed Clip Easy pry-open push-close clip N/A with -C	-S Screen Tabs Coming Soon	-TS Thumb Screw 	-CS Countersunk Screw

Finish		
<input type="checkbox"/> /W White (Default)	<input type="checkbox"/> /M Mill	<input type="checkbox"/> Custom (Please Specify)



Schedule type: _____

Job: _____

Architect: _____

Engineer: _____

Contractor: _____

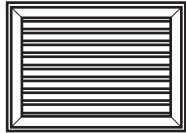
SUBMITTAL SHEET

Filter Return Grille for T-Bar Mount

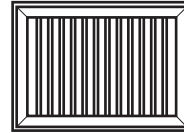
- Material:** Aluminum frame and fins
Hinged extrusion on one end, easy pry-open or push-close clip
- Mounting:** Lay-in T-bar ceiling.
No mounting holes on sub-frame.
- Grille core:** Fin spacing: 2/3"
- Filter:** 1" filter: Listed size - 2 7/8" (supplied by others)



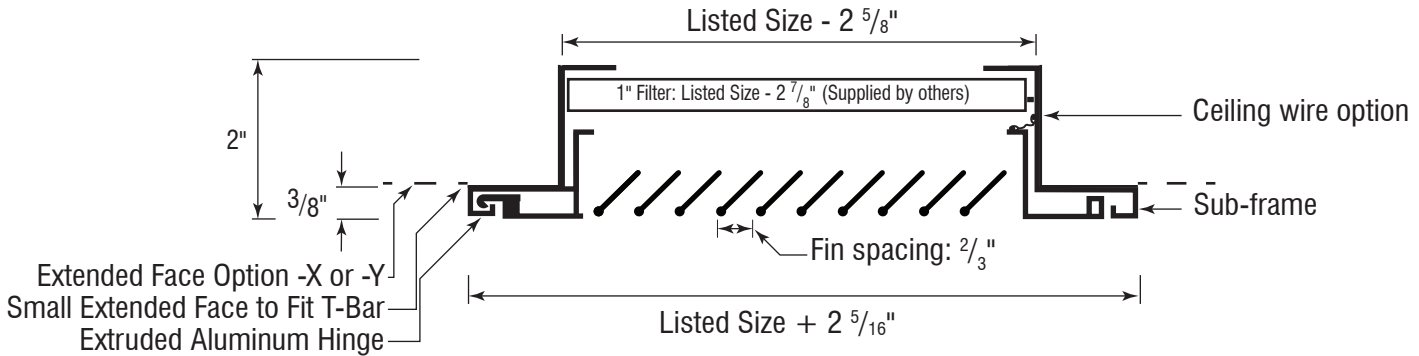
FGRT



FGRT



FGRT-V



Filter Options				
-F0 No Filter N/A with -C	-F0.5 0.5" Filter 	-F1 1" Filter 	-F2 2" Filter 	-F4 4" Filter

Options			Fins
-CW Security Ceiling Wire	-DS Debris (Bird) Screen	-IS Insect Screen	-FB 0° deflection

Panel Option for T-bar lay-in Ceiling		
	Steel (WxH)	Aluminum (WxH)
	<input type="checkbox"/> -X1212	<input type="checkbox"/> -Y1212
	<input type="checkbox"/> -X2412	<input type="checkbox"/> -Y2412
	<input type="checkbox"/> -X2424	<input type="checkbox"/> -Y2424
	<input type="checkbox"/> -X4824	<input type="checkbox"/> -Y4824
	<input type="checkbox"/> -X2020	<input type="checkbox"/> -Y2020

No mounting options available

Latching Options			
-C (Default) Concealed Clip Easy pry-open push-close clip N/A with -C	-S Screen Tabs Coming Soon	-TS Thumb Screw 	-CS Countersunk Screw

Finish		
<input type="checkbox"/> /W White (Default)	<input type="checkbox"/> /M Mill	<input type="checkbox"/> Custom (Please Specify)



Schedule type: _____

Job: _____

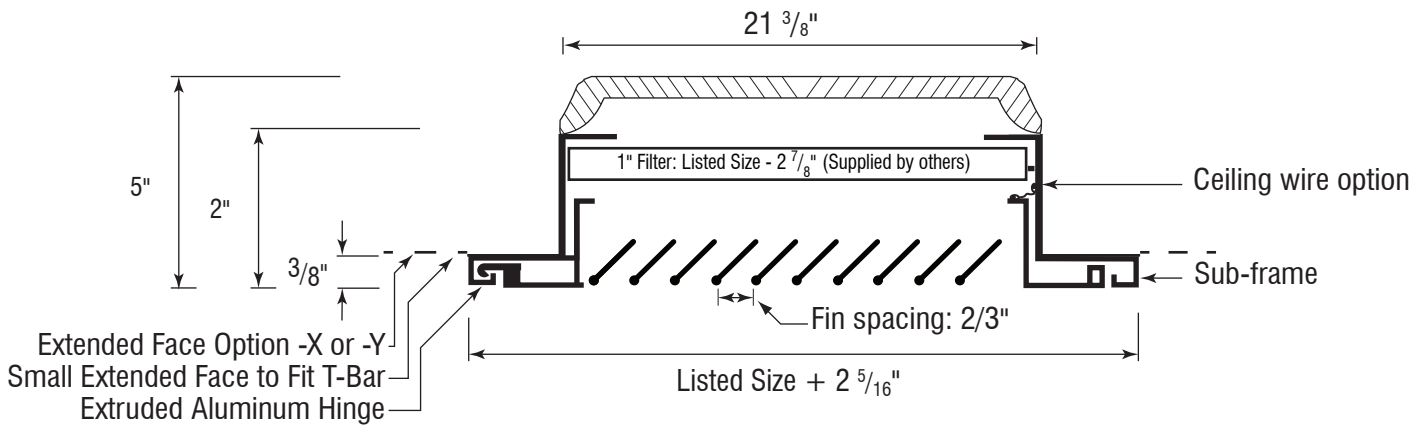
Architect: _____

Engineer: _____

Contractor: _____

Filter Return Grille for T-Bar Mount

- Material:** Aluminum frame and fins
Hinged extrusion on one end, easy pry-open or push-close clip
- Mounting:** Lay-in T-bar ceiling.
No mounting holes on sub-frame.
- Grille core:** Fin spacing: 2/3"
- Filter:** 1" filter: Listed size - 2 7/8" (supplied by others)
- Insulation:** R6 Moded Fiberglass


FGRTI


Latching Options			
<input type="checkbox"/> -C (Default) Concealed Clip Easy pry-open push-close clip N/A with -C	<input type="checkbox"/> -S Screen Tabs Coming Soon	<input type="checkbox"/> -TS Thumb Screw	<input type="checkbox"/> -CS Countersunk Screw

Finish		
<input type="checkbox"/> /W White (Default)	<input type="checkbox"/> /M Mill	<input type="checkbox"/> Custom (Please Specify)



Filter Options	Options	Fins
<input type="checkbox"/> -F0 No Filter N/A with -C	<input type="checkbox"/> -F1 1" Filter (Default) 	<input type="checkbox"/> -CW Security Ceiling Wire
		<input type="checkbox"/> -FB 0° deflection

Schedule type: _____

Job: _____

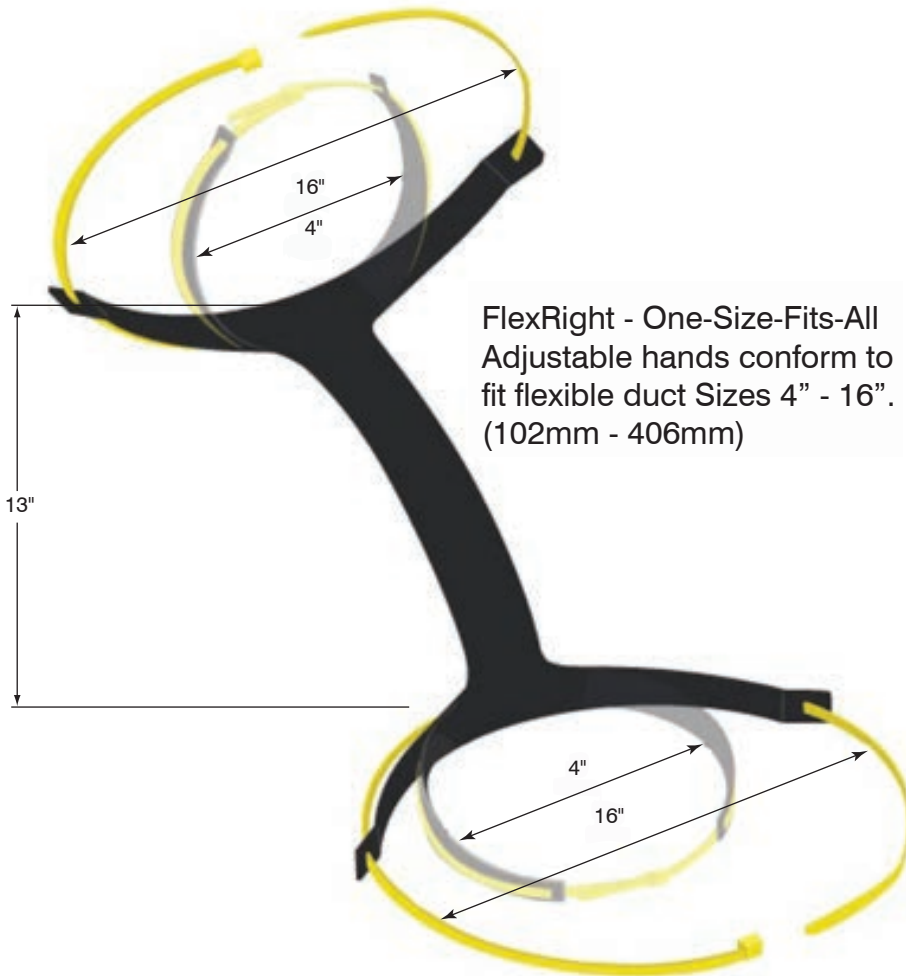
Architect: _____

Engineer: _____

Contractor: _____

FlexRight - Radius forming brace for flexible ducts

- Material:** 100% recycled, UL listed materials.
- Mounting:** Install on diffuser collar and round flex duct. Fits collars and flex ducts 4" - 16".



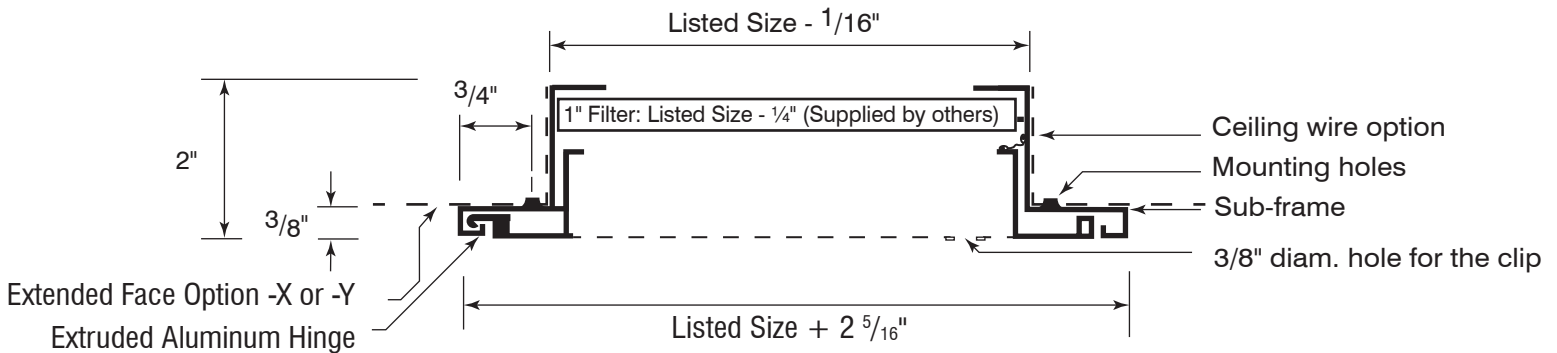
Schedule type: _____
Job: _____
Architect: _____
Engineer: _____
Contractor: _____

Perforated Filter Return Grille for Surface Mount

- Material:** Aluminum frame
Steel perforated face with 3/16" diam. holes
Hinged extrusion on one end,
easy pry-open or push-close clip
- Mounting:** Surface mounting
Countersunk mounting holes on sub-frame.
- Filter:** 1" filter: Listed size - 1/4" (supplied by others)



FPPE



Filter Options			
-F0 No Filter 	-F1 1" Filter 	-F3 2" Filter 	-F4 4" Filter

Options			Fins
-CW Security Ceiling Wire	-DS Debris (Bird) Screen	-IS Insect Screen	-FB 0° deflection

Panel Option for T-bar lay-in Ceiling		
	Steel (WxH)	Aluminum (WxH)
	<input type="checkbox"/> -X1212	<input type="checkbox"/> -Y1212
	<input type="checkbox"/> -X2412	<input type="checkbox"/> -Y2412
	<input type="checkbox"/> -X2424	<input type="checkbox"/> -Y2424
	<input type="checkbox"/> -X4824	<input type="checkbox"/> -Y4824
	<input type="checkbox"/> -X2020	<input type="checkbox"/> -Y2020

No mounting options available

Latching Options			
-C (Default) Concealed Clip 	-S Screen Tabs 	-TS Thumb Screw 	-CS Countersunk Screw

Finish		
<input type="checkbox"/> /W White (Default)	<input type="checkbox"/> /M Mill	<input type="checkbox"/> Custom (Please Specify)



Schedule type: _____

Job: _____

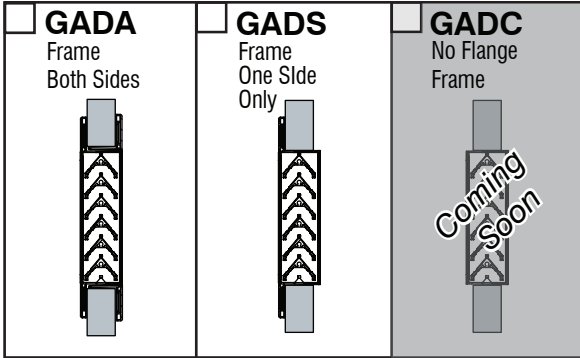
Architect: _____

Engineer: _____

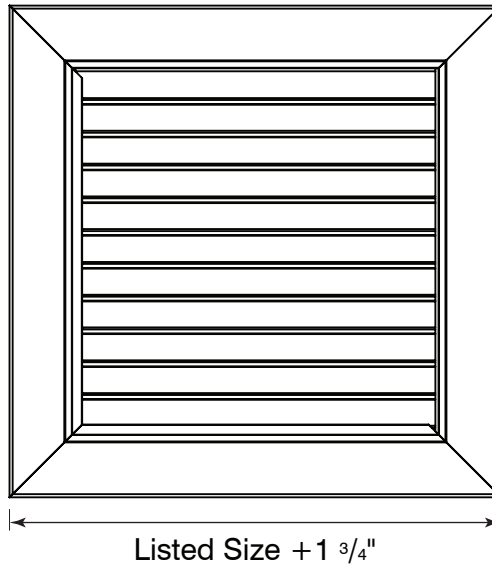
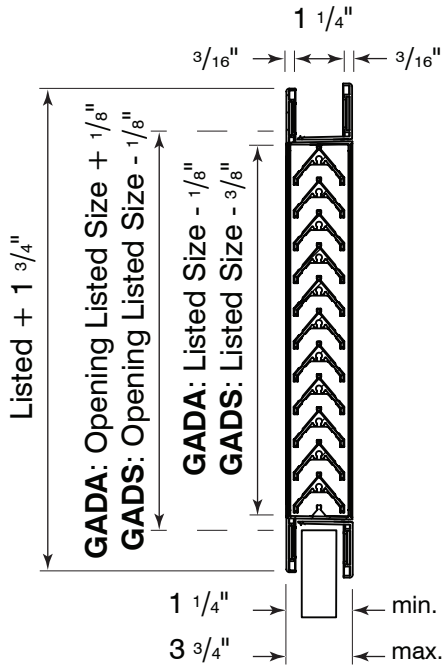
Contractor: _____

SUBMITTAL SHEET

Sight Proof Heavy Duty Aluminum Transfer Air Door Grille



GADA



Finish		
<input type="checkbox"/> /W White <small>(default)</small>	<input type="checkbox"/> /M Mill	<input type="checkbox"/> Custom _____ <small>(please specify)</small>

Schedule type: _____
Job: _____
Architect: _____
Engineer: _____
Contractor: _____

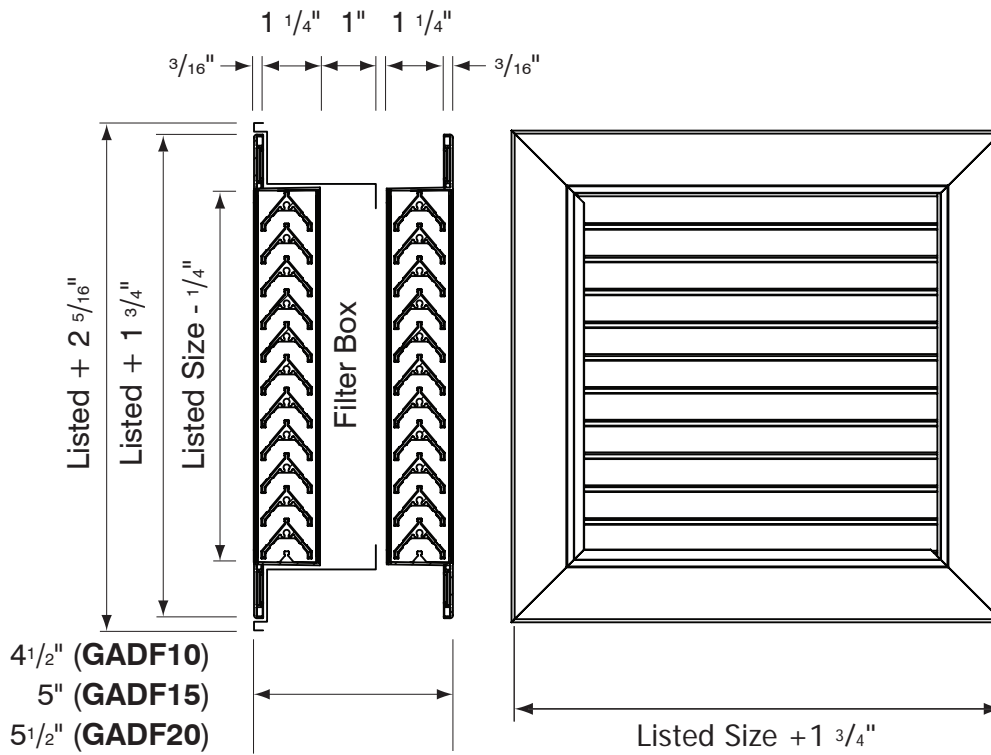
Filter Model GADF

- GADF10 1" filter
- GADF15 1.5" filter
- GADF20 2" filter



GADF
(Filter Door Grille)

SUBMITTAL SHEET



Finish		
<input type="checkbox"/> /W White <small>(default)</small>	<input type="checkbox"/> /M Mill	<input type="checkbox"/> Custom _____ <small>(please specify)</small>

Schedule type: _____
Job: _____
Architect: _____
Engineer: _____
Contractor: _____

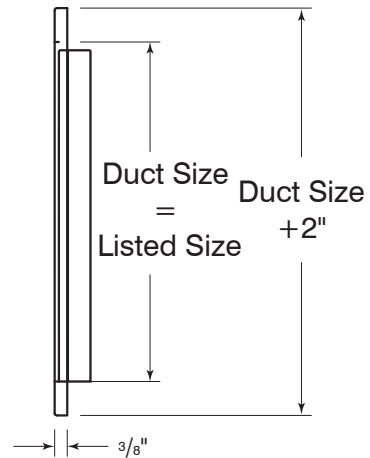
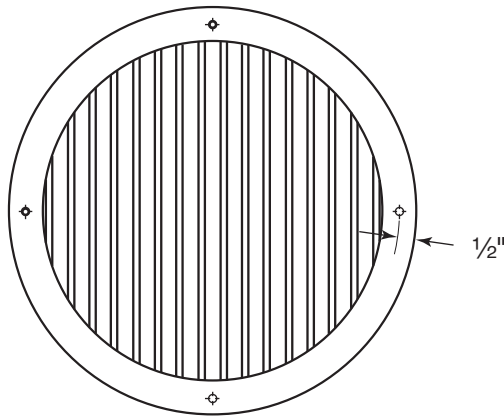
Round Single Deflection Grille

Material: Heavy gauge aluminum, roll-formed fins.
Finish: Powder paint coating - white.
Mounting: Surface mounting.
 Countersunk mounting holes on frame.



Fin spacing

- GAR11** (Default)
- GAR12**
- GAR13**



✓	Model #	Duct Size
	GAR1 06	6"
	GAR1 08	8"
	GAR1 10	10"
	GAR1 12	12"
	GAR1 14	14"
	GAR1 16	16"
	GAR1 18	18"
	GAR1 20	20"
	GAR1 22	22"
	GAR1 24	24"

Finish	
<input type="checkbox"/> /W White (Default)	<input type="checkbox"/> /C Custom (Please Specify)



Schedule type: _____

Job: _____

Architect: _____

Engineer: _____

Contractor: _____

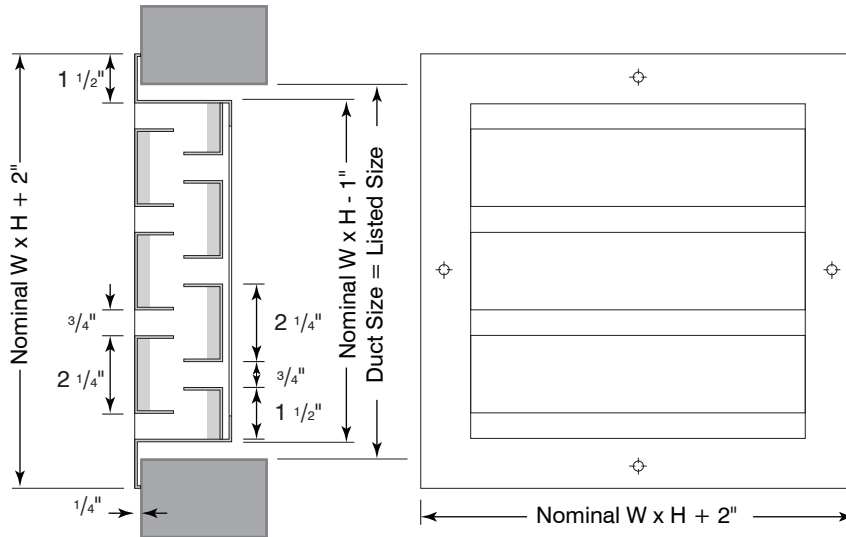
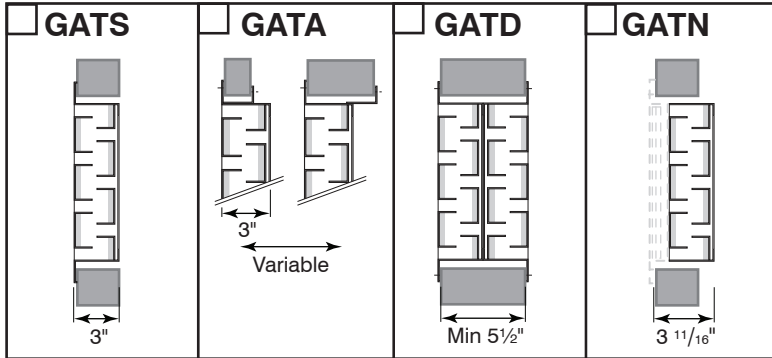
Acoustic Transfer Grille

Material: Extruded Aluminum.
Finish: Powder paint coating - white.
Mounting: Surface mounting.



GATS

SUBMITTAL SHEET



Nominal Width	Nominal Height
6" min. to 41" max.	5" min. to 41" max. in 3" increments

Finish	
<input type="checkbox"/> /W White (Default)	<input type="checkbox"/> /C Custom (Please Specify)



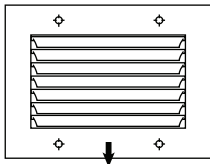
Schedule type: _____
 Job: _____
 Architect: _____
 Engineer: _____
 Contractor: _____

1 Way Adjustable Curved Blade Supply Grille Recessed Blades

- Material:** Extruded aluminum with mechanically fastened corners.
- Mounting:** Drywall or any surface mounting. Countersunk mounting holes on frame.
- Air Pattern:** 90° Diffusion.
Adjustable blades 2/3" spacing.



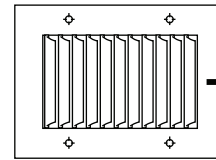
GCB10



(Default)

Standard discharge pattern (Vertical)

- GCB10-WV**
- GCB17-WV With OBD**



Alternate discharge pattern (Horizontal)

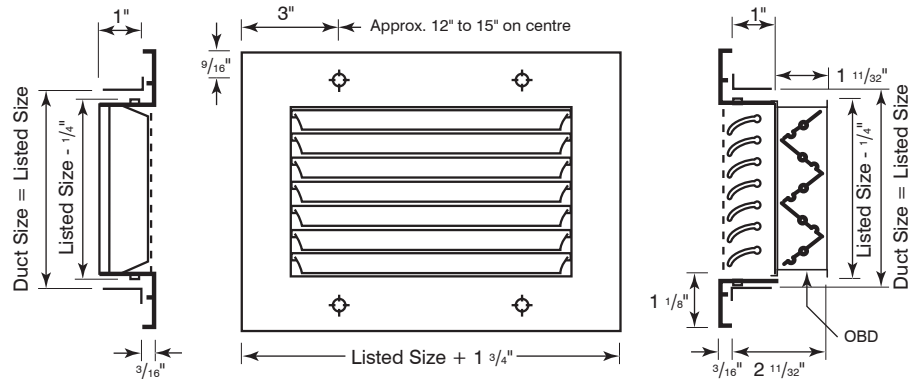
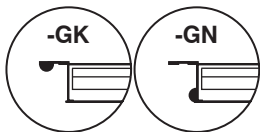
- GCB10-WH**
- GCB17-WH With OBD**

Blade Deflection Options

- Adjustable Blades (default) **-AB**
- Fixed Blades **-FB**

Options

- Supplied w/sub frame **-SF**
- Debris (Bird) Screen **-DS**
- Insect Screen **-IS**
- Flange Gasket **-GK**
- Neck Gasket **-GN**
- One Piece **-U**



Panel Option for T-bar lay-in Ceiling

	Steel (WxH)	Aluminum (WxH)
<input type="checkbox"/>	-X1212	-Y1212
<input type="checkbox"/>	-X1224	-Y1224
<input type="checkbox"/>	-X2412	-Y2412
<input type="checkbox"/>	-X2424	-Y2424
<input type="checkbox"/>	-X2448	-Y2448
<input type="checkbox"/>	-X4824	-Y4824
<input type="checkbox"/>	-X2020	-Y2020

No fastening options available

Fastening Method				
-1 No Fastening	-2 Spring clip	-3 Screw holes (Standard)	-4 Concealed	-6 Adhesive tape

Finish				
<input type="checkbox"/> /W White (default)	<input type="checkbox"/> /B Brushed Aluminum	<input type="checkbox"/> /M Mill Finish	<input type="checkbox"/> /L Brushed & Lacquered	<input type="checkbox"/> /C Custom (Please Specify)



Schedule type: _____

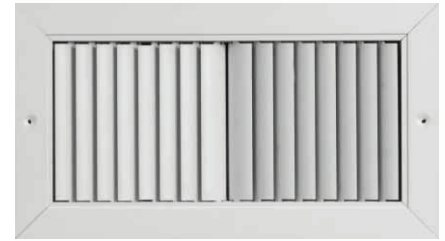
Job: _____

Architect: _____

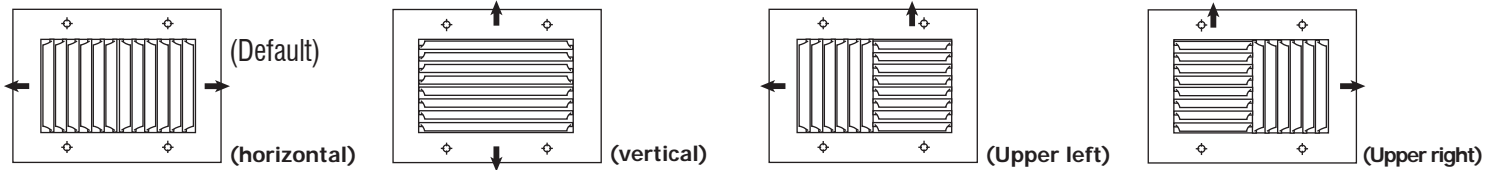
Engineer: _____

Contractor: _____

2 Way Adjustable Curved Blade Supply Grille Recessed Blades


GCB20

- Material:** Extruded aluminum with mechanically fastened corners.
- Mounting:** Drywall or any surface mounting. Countersunk mounting holes on frame.
- Air Pattern:** 90° or 180° Diffusion. Adjustable blades 2/3" spacing.



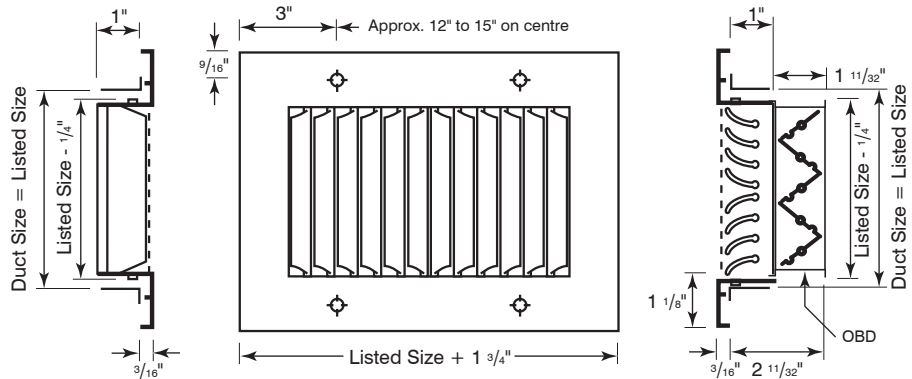
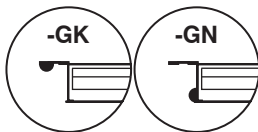
- | | | | |
|---|--|--|--|
| <input type="checkbox"/> Standard discharge pattern | <input type="checkbox"/> Alternate discharge pattern | <input type="checkbox"/> Alternate discharge pattern | <input type="checkbox"/> Alternate discharge pattern |
| <input type="checkbox"/> GCB20-WOH | <input type="checkbox"/> GCB20-WOV | <input type="checkbox"/> GCB20-WUL | <input type="checkbox"/> GCB20-WUR |
| <input type="checkbox"/> GCB27-WOH With OBD | <input type="checkbox"/> GCB27-WOV With OBD | <input type="checkbox"/> GCB27-WUL With OBD | <input type="checkbox"/> GCB27-WUR With OBD |

Blade Deflection Options

- Adjustable Blades (default) **-AB**
- Fixed Blades **-FB**

Options

- Supplied w/sub frame **-SF**
- Debris (Bird) Screen **-DS**
- Insect Screen **-IS**
- Flange Gasket **-GK**
- Neck Gasket **-GN**
- One Piece **-U**



Panel Option for T-bar lay-in Ceiling

	Steel (WxH)	Aluminum (WxH)
	<input type="checkbox"/> -X1212	<input type="checkbox"/> -Y1212
	<input type="checkbox"/> -X1224	<input type="checkbox"/> -Y1224
	<input type="checkbox"/> -X2412	<input type="checkbox"/> -Y2412
	<input type="checkbox"/> -X2424	<input type="checkbox"/> -Y2424
	<input type="checkbox"/> -X2448	<input type="checkbox"/> -Y2448
	<input type="checkbox"/> -X4824	<input type="checkbox"/> -Y4824
	<input type="checkbox"/> -X2020	<input type="checkbox"/> -Y2020
	No fastening options available	

Fastening Method

-1	-2	-3	-4	-6
No Fastening	Spring clip	Screw holes (Standard)	Concealed	Adhesive tape

Finish

/W	/B	/M	/L	/C Custom (Please Specify)
White (default)	Brushed Aluminum	Mill Finish	Brushed & Lacquered	



Schedule type: _____

Job: _____

Architect: _____

Engineer: _____

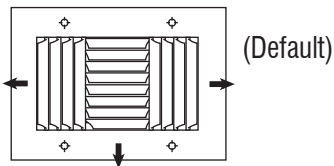
Contractor: _____

3 Way Adjustable Curved Blade Supply Grille Recessed Blades

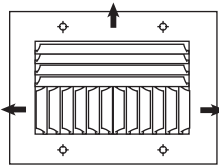
- Material:** Extruded aluminum with mechanically fastened corners.
- Mounting:** Drywall or any surface mounting. Countersunk mounting holes on frame.
- Air Pattern:** 270° Diffusion. Adjustable blades 2/3" spacing.



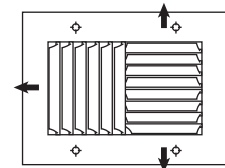
GCB30



- Standard discharge pattern**
- GCB30-WS**
 - GCB37-WS** With OBD



- Alternate discharge pattern (long)**
- GCB30-WL**
 - GCB37-WL** With OBD



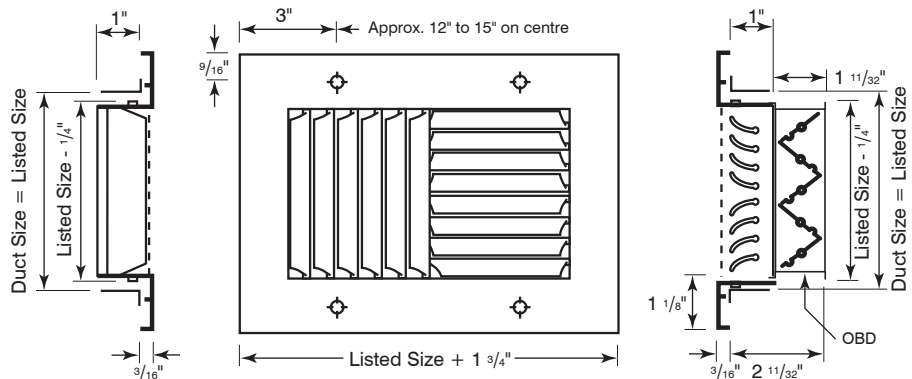
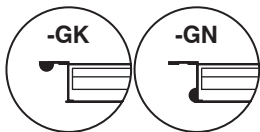
- Alternate discharge pattern**
- GCB30-WA**
 - GCB37-WA** With OBD

Blade Deflection Options

- Adjustable Blades (default) **-AB**
- Fixed Blades **-FB**

Options

- Supplied w/sub frame **-SF**
- Debris (Bird) Screen **-DS**
- Insect Screen **-IS**
- Flange Gasket **-GK**
- Neck Gasket **-GN**
- One Piece **-U**



Fastening Method

-1 No Fastening	-2 Spring clip	-3 Screw holes (Standard)	-4 Concealed	-6 Adhesive tape

Finish

<input type="checkbox"/> /W White (default)	<input type="checkbox"/> /B Brushed Aluminum	<input type="checkbox"/> /M Mill Finish	<input type="checkbox"/> /L Brushed & Lacquered	<input type="checkbox"/> /C Custom (Please Specify)
--	---	--	--	---



Panel Option for T-bar lay-in Ceiling

	Steel (WxH)	Aluminum (WxH)
	<input type="checkbox"/> -X1212	<input type="checkbox"/> -Y1212
	<input type="checkbox"/> -X1224	<input type="checkbox"/> -Y1224
	<input type="checkbox"/> -X2412	<input type="checkbox"/> -Y2412
	<input type="checkbox"/> -X2424	<input type="checkbox"/> -Y2424
	<input type="checkbox"/> -X2448	<input type="checkbox"/> -Y2448
	<input type="checkbox"/> -X4824	<input type="checkbox"/> -Y4824
	<input type="checkbox"/> -X2020	<input type="checkbox"/> -Y2020

No fastening options available

Schedule type: _____

Job: _____

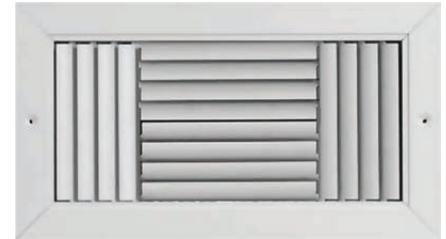
Architect: _____

Engineer: _____

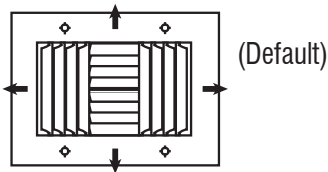
Contractor: _____

4 Way Adjustable Curved Blade Supply Grille Recessed Blades

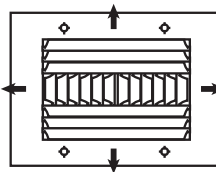
- Material:** Extruded aluminum with mechanically fastened corners.
- Mounting:** Drywall or any surface mounting. Countersunk mounting holes on frame.
- Air Pattern:** 360° Diffusion.
Adjustable blades 2/3" spacing.


GCB40

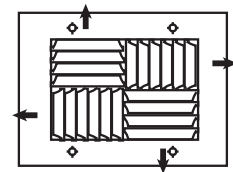
SUBMITTAL SHEET


Standard Discharge Pattern

- GCB40-WS**
- GCB47-WS** With OBD


Alternate Discharge Pattern (long)

- GCB40-WL**
- GCB47-WL** With OBD


Alternate Discharge Pattern

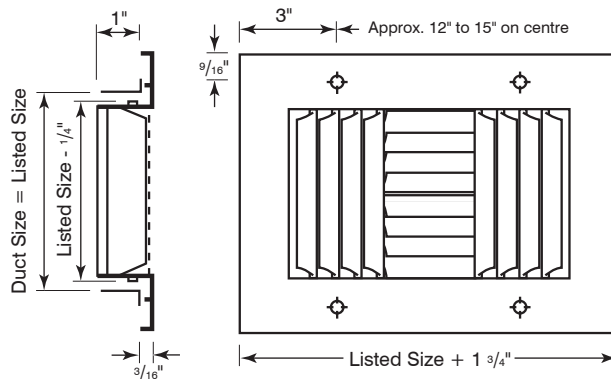
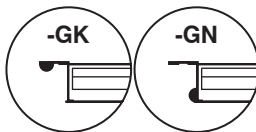
- GCB40-WA**
- GCB47-WA** With OBD

Blade Deflection Options

- Adjustable Blades (default) **-AB**
- Fixed Blades **-FB**

Options

- Supplied w/sub frame **-SF**
- Debris (Bird) Screen **-DS**
- Insect Screen **-IS**
- Flange Gasket **-GK**
- Neck Gasket **-GN**
- One Piece **-U**



Panel Option for T-bar lay-in Ceiling

	Steel (WxH)	Aluminum (WxH)
	<input type="checkbox"/> -X1212	<input type="checkbox"/> -Y1212
	<input type="checkbox"/> -X1224	<input type="checkbox"/> -Y1224
	<input type="checkbox"/> -X2412	<input type="checkbox"/> -Y2412
	<input type="checkbox"/> -X2424	<input type="checkbox"/> -Y2424
	<input type="checkbox"/> -X2448	<input type="checkbox"/> -Y2448
	<input type="checkbox"/> -X4824	<input type="checkbox"/> -Y4824
	<input type="checkbox"/> -X2020	<input type="checkbox"/> -Y2020
	No fastening options available	

Fastening Method

-1	-2	-3	-4	-6
No Fastening	Spring clip	Screw holes (Standard)	Concealed	Adhesive tape

Finish

/W	/B	/M	/L	/C Custom (Please Specify)
White (default)	Brushed Aluminum	Mill Finish	Brushed & Lacquered	



Schedule type: _____

Job: _____

Architect: _____

Engineer: _____

Contractor: _____

SUBMITTAL SHEET

Single Deflection Spiral Duct Grille Adjustable Air Pattern

- Material:** Aluminum construction.
Adjustable blades.
- Finish:** Powder paint coating - white.
- Mounting:** Countersunk mounting holes on frame.
- Spacing:** 2/3" Blade Spacing



GDA10

Horizontal Face Blades

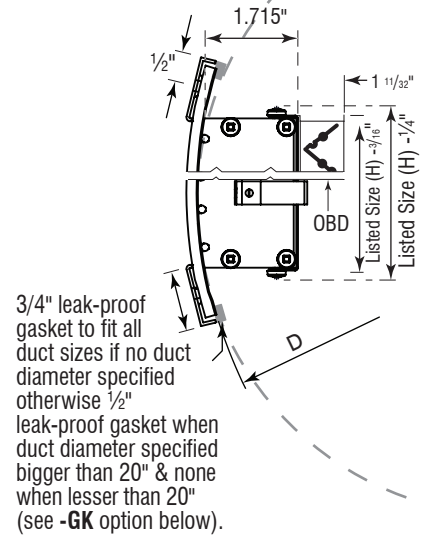
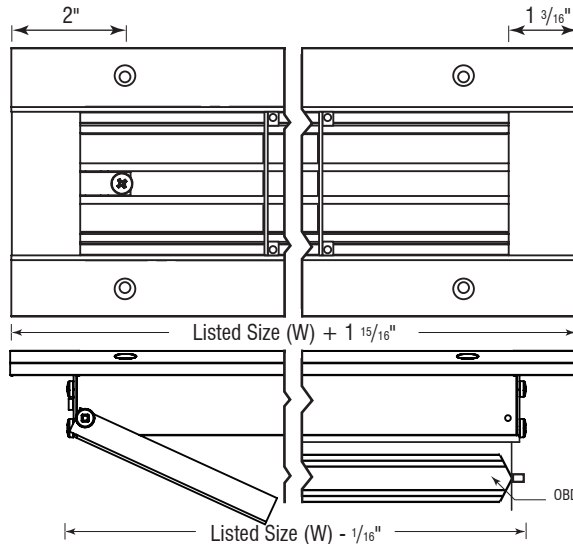
- GDA10-H** Aluminum Fins
- GDA17-H** Steel Opposed Blade Damper
- GDA18-H** Aluminum Fins with Air Scoop

Vertical Face Blades

- GDA10-V** Aluminum Fins
- GDA17-V** Steel Opposed Blade Damper
- GDA18-V** Aluminum Fins with Air Scoop

Nice feature: Fins follow the curve on the face of the grille.

- Super easy to order and keep stock!
- No need to specify duct dimension!
- Just width and height of the grille!



Duct D (in inches)	Duct Cut Out Opening (H)					
	3"	4"	6"	8"	10"	12"
-D06	3"	4 ^{3/8} "				
-D08	3"	4 ^{1/4} "	6 ^{3/4} "			
-D10	3"	4 ^{1/8} "	6 ^{1/4} "	9 ^{1/4} "		
-D12	3"	4 ^{1/8} "	6 ^{1/4} "	8 ^{3/4} "	11 ^{3/4} "	
-D14	3"	4"	6 ^{1/4} "	8 ^{1/4} "	11 ^{1/8} "	14 ^{3/8} "
-D16	3"	4"	6 ^{1/8} "	8 ^{3/8} "	10 ^{3/4} "	13 ^{1/4} "
-D18	3"	4"	6 ^{1/8} "	8 ^{1/4} "	10 ^{5/8} "	13 ^{1/8} "
-D20	3"	4"	6 ^{1/8} "	8 ^{1/4} "	10 ^{1/4} "	12 ^{7/8} "
-D22	3"	4"	6 ^{1/8} "	8 ^{1/4} "	10 ^{3/8} "	12 ^{3/4} "
-D24	3"	4"	6"	8 ^{1/8} "	10 ^{1/4} "	12 ^{1/4} "
-D26	3"	4"	6"	8 ^{1/8} "	10 ^{1/4} "	12 ^{1/4} "
-D34	3"	4"	6"	8"	10 ^{1/8} "	12 ^{1/4} "
-D44	3"	4"	6"	8"	10"	12 ^{1/8} "
Over 64	3"	4"	6"	8"	10"	12"
Universal/Default Duct Diameter	-D10*	-D08*	-D14*	-D18*	-D26*	-D26*

Options

-GK (1/2" x 1/2" thick)
Flange Gasket (included over 20" D)



Finish

/W White (Default) /M Mill Finish **Custom** (Please Specify)

Schedule type: _____

Job: _____

Architect: _____

Engineer: _____

Contractor: _____

See bold-border box in the column above.

Can specify exact duct diameter or not. If no diameter specified, then **universal/default** duct diameter is used and a 3/4" leak-proof gasket is used to fit all duct sizes.

Not recommended, grille neck blocking air flow. Try smaller height and longer grille. Must **specify exact duct diameter** if you really want this size.

Not possible. Will not fit the duct. Universal/Default duct diameter will not fit for these duct sizes. Must **specify exact duct diameter** if you really want this size. Best to try smaller height and longer grille in order to use a **universal/default** sized grille.

Double Deflection Spiral Duct Grille Adjustable Air Pattern

- Material:** Aluminum construction.
Adjustable blades.
- Finish:** Powder paint coating - white.
- Mounting:** Countersunk mounting holes on frame.
- Spacing:** 2/3" Blade Spacing


GDA28

Horizontal Face Blades

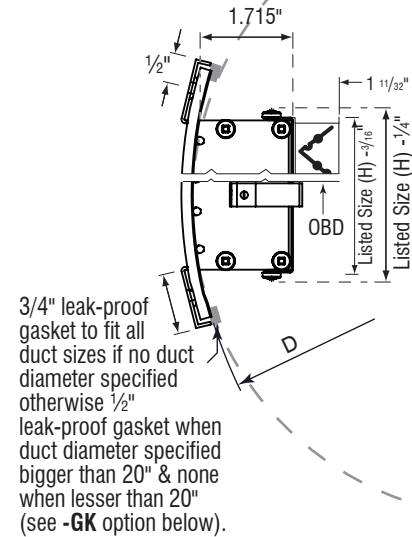
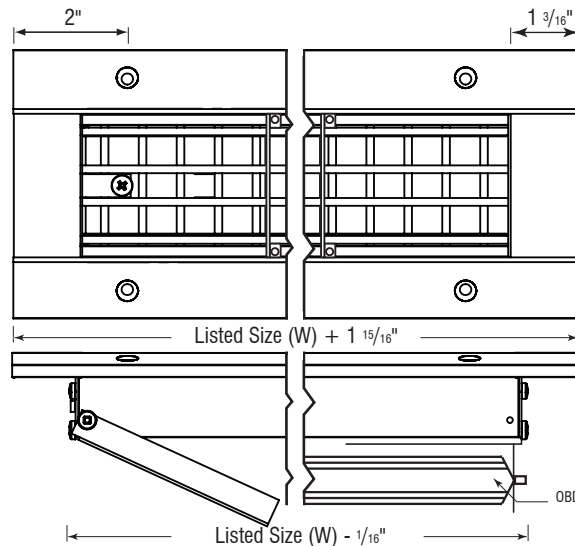
- GDA20-H** Aluminum Fins
- GDA27-H** Steel Opposed Blade Damper
- GDA28-H** Aluminum Fins with Air Scoop

Vertical Face Blades

- GDA20-V** Aluminum Fins
- GDA27-V** Steel Opposed Blade Damper
- GDA28-V** Aluminum Fins with Air Scoop

Nice feature: Fins follow the curve on the face of the grille.

- Super easy to order and keep stock!
- No need to specify duct dimension!
- Just width and height of the grille!



Duct D (in inches)	Duct Cut Out Opening (H)					
	3"	4"	6"	8"	10"	12"
-D06	3"	4 ^{3/8} "				
-D08	3"	4 ^{1/4} "	6 ^{3/4} "			
-D10	3"	4 ^{1/8} "	6 ^{1/4} "	9 ^{1/4} "		
-D12	3"	4 ^{1/8} "	6 ^{1/4} "	8 ^{3/4} "	11 ^{3/4} "	
-D14	3"	4"	6 ^{1/4} "	8 ^{1/4} "	11 ^{1/8} "	14 ^{3/8} "
-D16	3"	4"	6 ^{1/8} "	8 ^{3/8} "	10 ^{3/4} "	13 ^{1/4} "
-D18	3"	4"	6 ^{1/8} "	8 ^{1/4} "	10 ^{5/8} "	13 ^{1/8} "
-D20	3"	4"	6 ^{1/8} "	8 ^{1/4} "	10 ^{1/4} "	12 ^{7/8} "
-D22	3"	4"	6 ^{1/8} "	8 ^{1/4} "	10 ^{3/8} "	12 ^{3/4} "
-D24	3"	4"	6"	8 ^{1/8} "	10 ^{1/4} "	12 ^{1/4} "
-D26	3"	4"	6"	8 ^{1/8} "	10 ^{1/4} "	12 ^{1/4} "
-D34	3"	4"	6"	8"	10 ^{1/8} "	12 ^{1/4} "
-D44	3"	4"	6"	8"	10"	12 ^{1/8} "
Over 64	3"	4"	6"	8"	10"	12"
Universal/Default Duct Diameter	-D10*	-D08*	-D14*	-D18*	-D26*	-D26*

*See bold-border box in the column above.

Can specify exact duct diameter or not. If no diameter specified, then **universal/default** duct diameter is used and a 3/4" leak-proof gasket is used to fit all duct sizes.

Not recommended, grille neck blocking air flow. Try smaller height and longer grille. Must **specify exact duct diameter** if you really want this size.

Not possible. Will not fit the duct. Universal/Default duct diameter will not fit for these duct sizes. Must **specify exact duct diameter** if you really want this size. Best to try smaller height and longer grille in order to use a **universal/default** sized grille.

Options

-GK (1/2" x 1/2" thick)

Flange Gasket
(included over 20" D)



Finish

/W White (Default) /M Mill Finish **Custom** (Please Specify)

Schedule type: _____

Job: _____

Architect: _____

Engineer: _____

Contractor: _____

SUBMITTAL SHEET

Single Deflection Spiral Duct Grille Adjustable Air Pattern

Material: Aluminum construction.
Extruded aluminum frame.
Coated steel perforated face with 3/16" diam. round holes on 1/4" staggered centers, affords 53% free area.

Finish: Powder paint coating - white.

Mounting: Screw holes mounting.

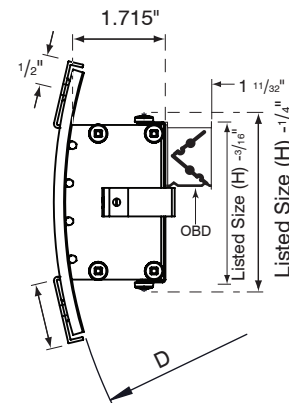
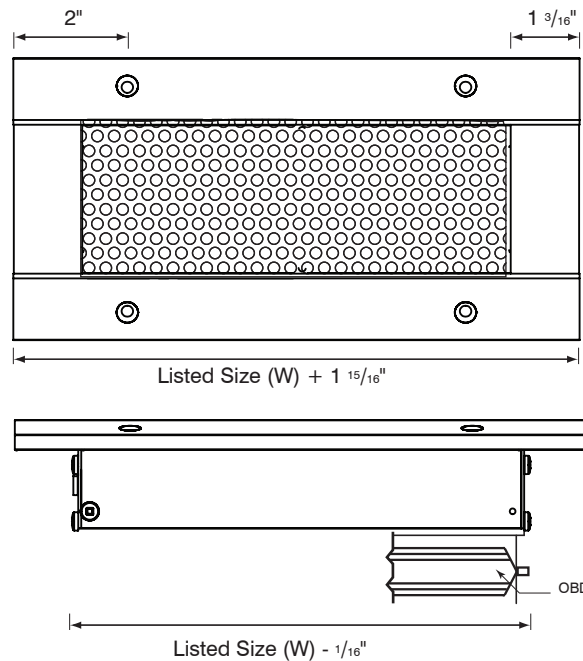
Spacing: 2/3" Blade Spacing.



GDPA

Perforated Face Grille

- GDPA0** Perforated Face
- GDPA7** Steel Opposed Blade Damper



Options

-GK (1/2"x 1/2" thick)

Flange Gasket
(included over 20" D)



Duct D	Duct Cut Out Opening					
	H = 3"	H = 4"	H = 6"	H = 8"	H = 10"	H = 12"
6"	3"					
8"	3"	4 1/4"				
10"	3"	4 1/8"	6 1/4"			
12"	3"	4 1/8"	6 1/4"	8 3/4"		
14"	3"	4"	6 1/4"	8 1/4"	11 1/8"	
16"	3"	4"	6 1/8"	8 3/8"	10 3/4"	13 1/4"
18"	3"	4"	6 1/8"	8 1/4"	10 5/8"	13 1/8"
20"	3"	4"	6 1/8"	8 1/4"	10 1/4"	12 7/8"
22"	3"	4"	6 1/8"	8 1/4"	10 3/8"	12 3/4"
24"	3"	4"	6"	8 1/8"	10 1/4"	12 1/4"
34"	3"	4"	6"	8"	10 1/8"	12 1/4"
44"	3"	4"	6"	8"	10"	12 1/8"
Over 64"	3"	4"	6"	8"	10"	12"

Finish		
<input type="checkbox"/> /W White (Default)	<input type="checkbox"/> /M Mill Finish	<input type="checkbox"/> Custom (Please Specify)

Schedule type: _____

Job: _____

Architect: _____

Engineer: _____

Contractor: _____

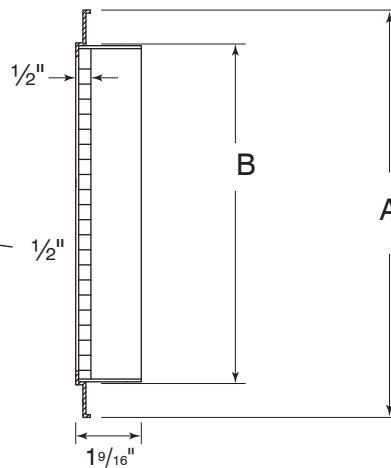
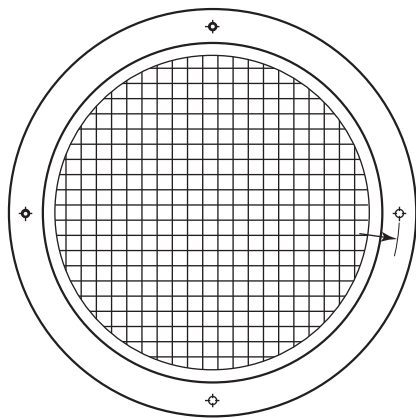
Round Egg Crate Grille

- Material:** All Aluminum, Aluminum grille 1/2" x 1/2" x 1/2".
- Finish:** Powder paint coating - white.
- Mounting:** Surface mounting.
Countersunk mounting holes on frame.
- Grid core:** Aluminum 1/2" x 1/2" x 1/2".

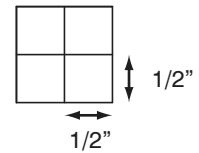


GER

SUBMITTAL SHEET



Egg crate core



✓	Model #	B	A
	GER 04	3 3/4"	8 7/8"
	GER 05	4 3/4"	7 7/8"
	GER 06	5 3/4"	8 7/8"
	GER 08	7 11/16"	11 13/16"
	GER 10	9 5/8"	13 13/16"
	GER 12	11 5/8"	14 3/8"

Finish	
<input type="checkbox"/> /W White (Default)	<input type="checkbox"/> /C Custom (Please Specify) _____



Schedule type: _____

Job: _____

Architect: _____

Engineer: _____

Contractor: _____

Double Deflection Heavy Duty Grille

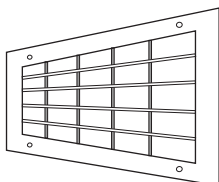
Material: Heavy duty extruded aluminum frame

Air Pattern: Adjustable air pattern

Horizontal Face Bars (Standard)

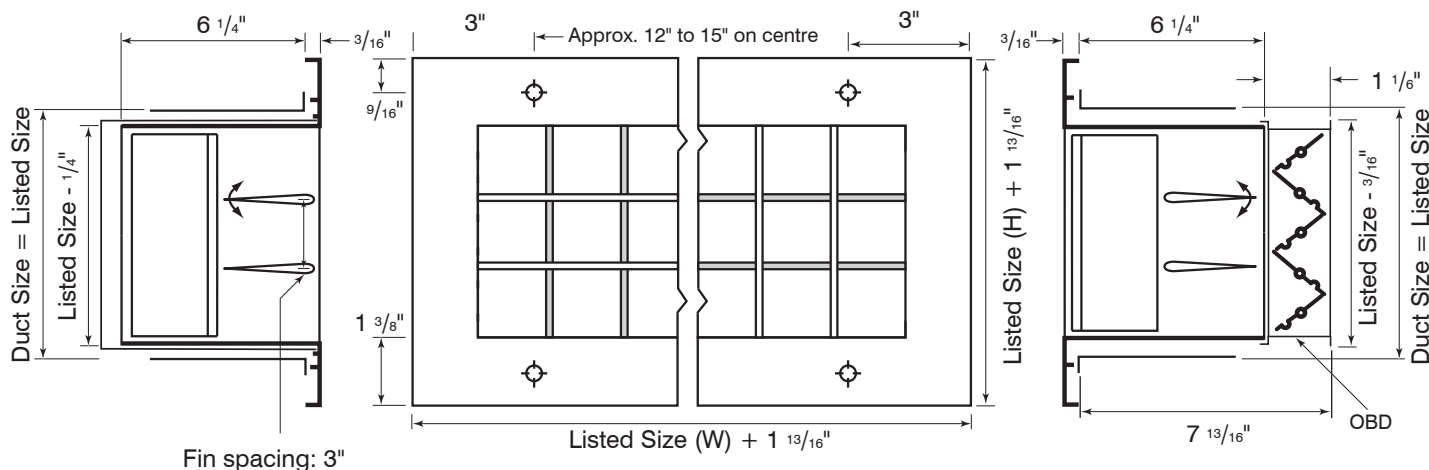
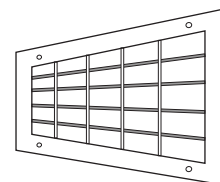
(Mullion required for w > 18")

- GHA20** Aluminum fins
- GHA27** Aluminum fins with steel OBD
- GHA29** Aluminum fins with alum. OBD



Vertical Face Bars

- GHA20-V** Aluminum fins
- GHA27-V** Aluminum fins with steel OBD
- GHA29-V** Aluminum fins with alum. OBD



Options				
<input type="checkbox"/> -GK Flange Gasket	<input type="checkbox"/> -GN Neck Gasket	<input type="checkbox"/> -GR Rear Gasket		
<input type="checkbox"/> -SF Supplied w/ sub frame	<input type="checkbox"/> -DS Debris (Bird) Screen	<input type="checkbox"/> -IS Insect Screen	<input type="checkbox"/> -HB Hemmed bracket for -4 option	<input type="checkbox"/> -FB Fixed Blades 0 degrees



Finish				
<input type="checkbox"/> /W White (default)	<input type="checkbox"/> /B Brushed Aluminium	<input type="checkbox"/> /M Mill Finish	<input type="checkbox"/> /L Brushed and Lacquered	<input type="checkbox"/> /C Custom (Please Specify)

Panel Option for T-bar lay-in Ceiling		
	Steel (WxH)	Aluminum (WxH)
	<input type="checkbox"/> -X1212	<input type="checkbox"/> -Y1212
	<input type="checkbox"/> -X1224	<input type="checkbox"/> -Y1224
	<input type="checkbox"/> -X2412	<input type="checkbox"/> -Y2412
	<input type="checkbox"/> -X2424	<input type="checkbox"/> -Y2424
	<input type="checkbox"/> -X2448	<input type="checkbox"/> -Y2448
	<input type="checkbox"/> -X4824	<input type="checkbox"/> -Y4824
	<input type="checkbox"/> -X2020	<input type="checkbox"/> -Y2020
No fastening options available		

Fastening Method				
<input type="checkbox"/> -1 No Fastening	<input type="checkbox"/> -2 Spring clip	<input type="checkbox"/> -3 Screw holes (Standard)	<input type="checkbox"/> -4 Concealed <small>See -HB option</small>	<input type="checkbox"/> -6 Adhesive tape
Schedule type: _____ Job: _____ Architect: _____ Engineer: _____ Contractor: _____				

Plenums for all grilles (GSA/GAA/ALB/ARCH/RAF/REAL)

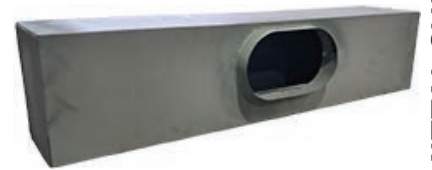
Material: 24 gauge galvalneal

GPL
H = 8"

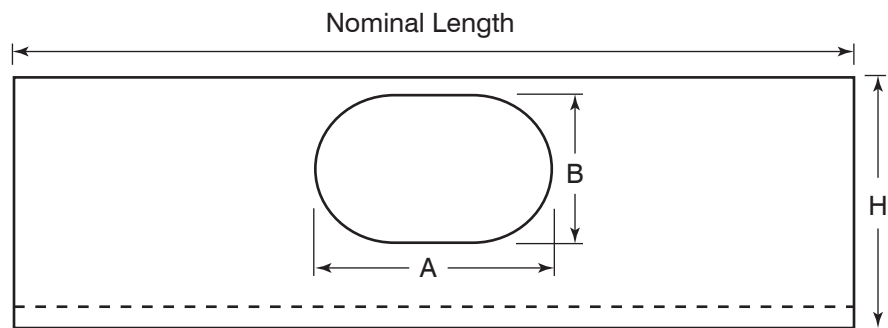
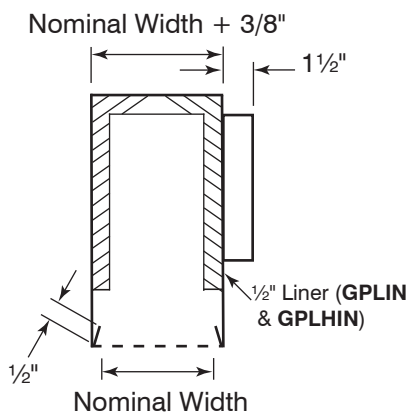
GPLIN - 1/2" Liner Insulation
H = 8"

GPLH
H = 11"

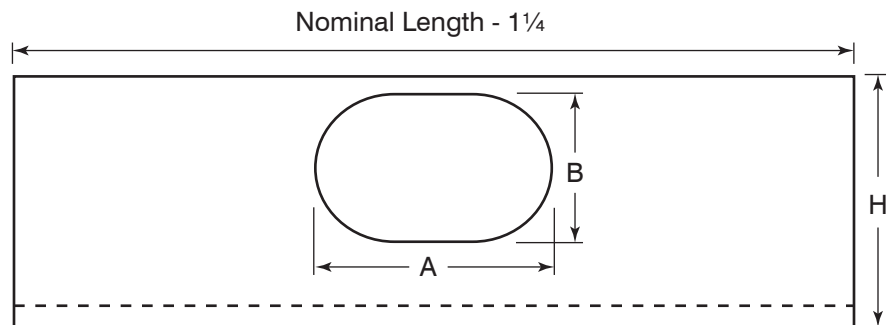
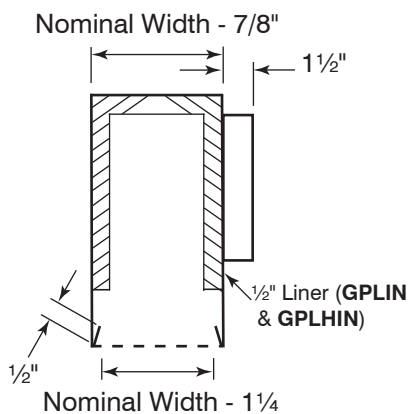
GPLHIN - 1/2" Liner Insulation
H = 11"



For standard surface mount application



For T-Bar Application only (Option -T) also for GRT



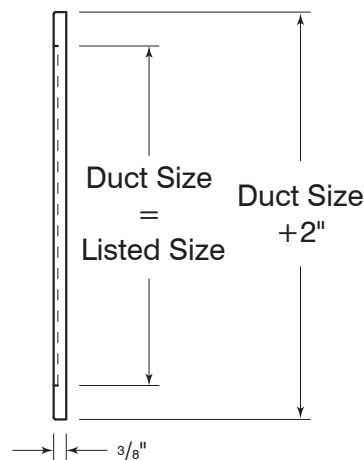
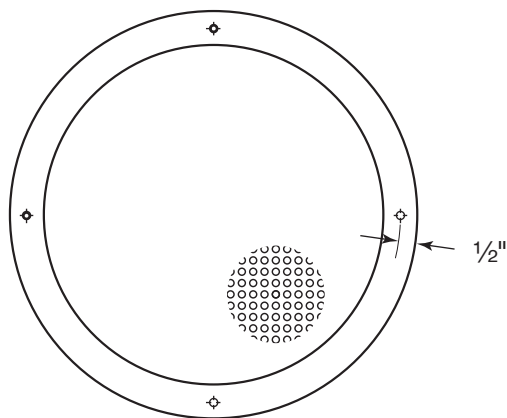
✓		Inlet Size	A	B
	-04	4"	4"	4"
	-05	5"	5"	5"
	-06	6"	6 ¹ / ₄ "	5 ¹ / ₄ "
	-08	8"	9 ³ / ₈ "	5 ¹ / ₄ "
	-10	10"	12 ¹ / ₂ "	5 ¹ / ₄ "
	-12*	12"	14 ¹ / ₈ "	7 ⁷ / ₈ "

* 12" oval neck available only with 11" high plenums

Schedule type: _____
Job: _____
Architect: _____
Engineer: _____
Contractor: _____

Round Perforated Flat Grilles

- Material:** Heavy gauge aluminum, face perforated.
- Finish:** Powder paint coating - white.
- Mounting:** Surface mounting.
Countersunk mounting holes on frame.



✓	Model #	Duct Size
	GPR 04	4"
	GPR 06	6"
	GPR 08	8"
	GPR 10	10"
	GPR 12	12"
	GPR 14	14"
	GPR 16	16"

Finish	
<input type="checkbox"/> /W White (Default)	<input type="checkbox"/> /C Custom (Please Specify)



Schedule type: _____

Job: _____

Architect: _____

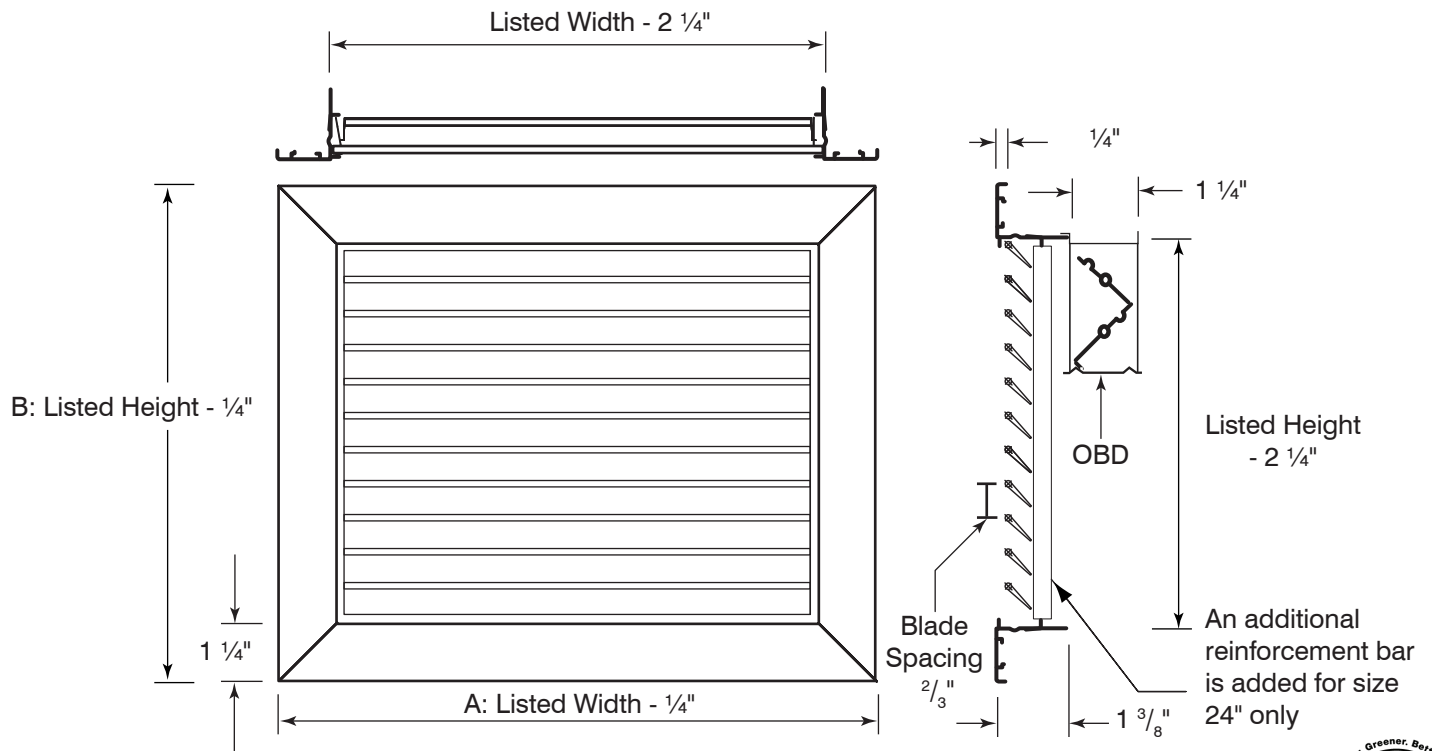
Engineer: _____

Contractor: _____

Ceiling Return Grille/Diffuser

Material: Aluminum construction.
 Fixed blades.
Finish: Powder paint white finish.
Mounting: For T-bar lay-in ceiling grids.

 GRT without Damper (default)

 GRT7 with Damper


✓	Model #	Face Dim. A x B	Neck Size.
	GRT/7 1212	11 $\frac{3}{4}"$ x 11 $\frac{3}{4}"$	10" x 10"
	GRT/7 2412	23 $\frac{3}{4}"$ x 11 $\frac{3}{4}"$	22" x 10"
	GRT/7 2424	23 $\frac{3}{4}"$ x 23 $\frac{3}{4}"$	22" x 22"
	GRT/7 4812	47 $\frac{3}{4}"$ x 11 $\frac{3}{4}"$	46" x 10"
	GRT/7 4824	47 $\frac{3}{4}"$ x 23 $\frac{3}{4}"$	46" x 22"

Finish		
<input type="checkbox"/> /W White <small>(default)</small>	<input type="checkbox"/> /M Mill	<input type="checkbox"/> /C Custom <small>(please specify)</small>

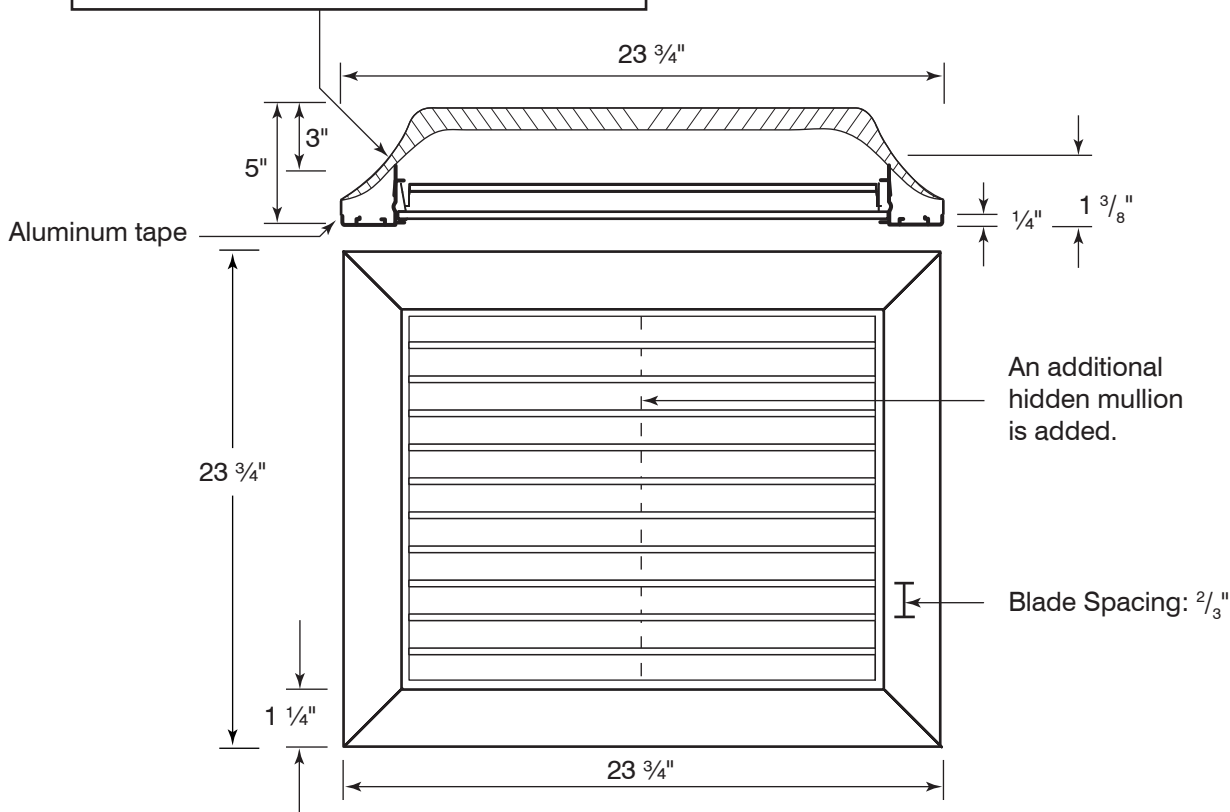
Schedule type: _____
 Job: _____
 Architect: _____
 Engineer: _____
 Contractor: _____

SUBMITTAL SHEET

Ceiling Return Grille/Diffuser

- Material:** Aluminum construction.
Fixed blades.
- Finish:** Powder paint white finish.
- Mounting:** For T-bar lay-in ceiling grids.
- Insulation:** -R6 opt. Molded Fiberglass.

Fiberglass back complies with A.S.T.M. E84 flame and smoke test. Scored for collar sizes up to 14" D.



Finish		
<input type="checkbox"/> /W White <small>(default)</small>	<input type="checkbox"/> /M Mill	<input type="checkbox"/> /C Custom <small>(please specify)</small>

Schedule type: _____

Job: _____

Architect: _____

Engineer: _____

Contractor: _____

Ceiling Return Grille/Diffuser

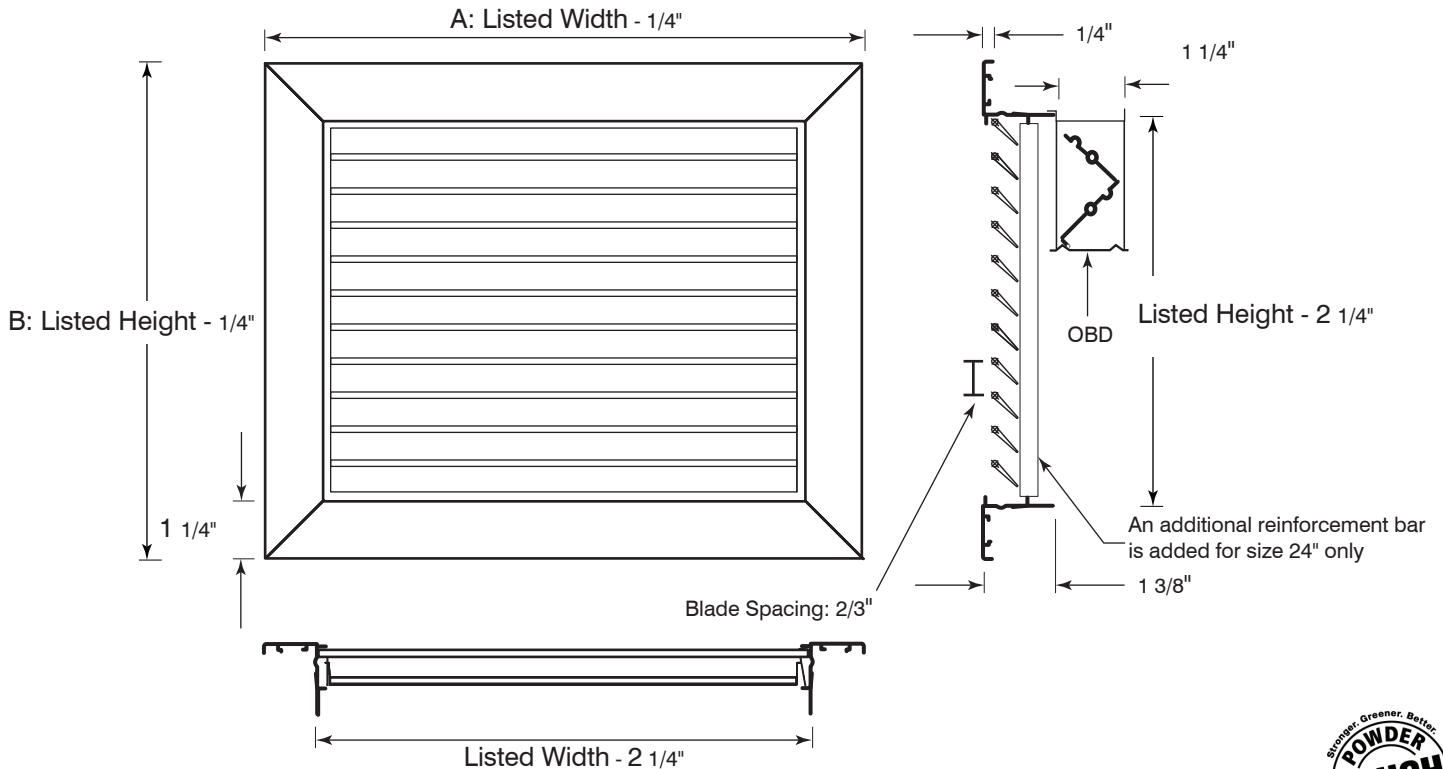
- Material:** Extruded aluminum frame.
Fixed blades.
- Finish:** Powder paint white finish.
- Mounting:** For T-bar lay-in ceiling grids.

Steel Bars

- GRTS** without Damper (default)
- GRTS7** with Damper

Aluminum Bars

- GRTA** without Damper (default)
- GRTA7** with Damper



✓	Model #	Face Dim. A x B	Neck Size
	GRTS/7 1212	11 3/4" x 11 3/4"	10" x 10"
	GRTS/7 2412	23 3/4" x 11 3/4"	22" x 10"
	GRTS/7 2424	23 3/4" x 23 3/4"	22" x 22"
	GRTS/7 4812	47 3/4" x 11 3/4"	46" x 10"
	GRTS/7 4824	47 3/4" x 23 3/4"	46" x 22"

Finish		
<input type="checkbox"/> /W White <small>(default)</small>	<input type="checkbox"/> /M Mill	<input type="checkbox"/> /C Custom <small>(please specify)</small>

Schedule type: _____

Job: _____

Architect: _____

Engineer: _____

Contractor: _____

Single Deflection Supply Grille Adjustable Air Pattern

Material: Extruded aluminum frame, roll-formed fins, some unapparent steel subcomponents.

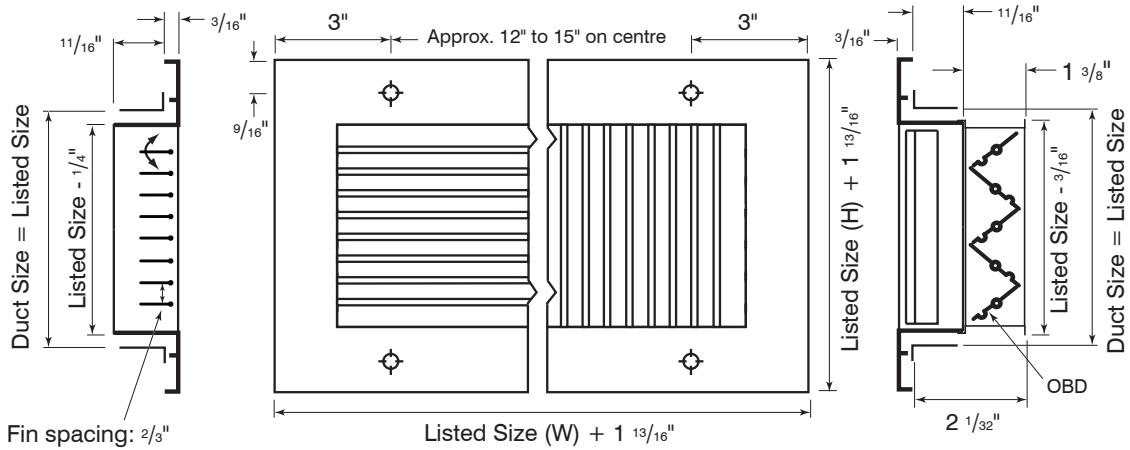
Horizontal Face Bars (Standard)
(Mullion required for w > 18")

- GSA10** Steel
- GSA17** Steel with OBD
- GAA10** Aluminum
- GAA17** Aluminum with OBD



Vertical Face Bars

- GSA10-V** Steel
- GSA17-V** Steel wwith OBD
- GAA10-V** Aluminum
- GAA17-V** Aluminum with OBD



Options			
-GK Flange Gasket	-GN Neck Gasket	-GR Rear Gasket	
-SF Supplied w/ sub frame	-DS Debris (Bird) Screen	-IS Insect Screen	-FB Fixed Blades 0 degrees

Fastening Method				
-1 No Fastening	-2 Spring clip	-3 Screw holes (Standard)	-4 Concealed	-6 Adhesive tape tape

Panel Option for T-bar lay-in Ceiling		
	Steel (WxH)	Aluminum (WxH)
	<input type="checkbox"/> -X1212	<input type="checkbox"/> -Y1212
	<input type="checkbox"/> -X1224	<input type="checkbox"/> -Y1224
	<input type="checkbox"/> -X2412	<input type="checkbox"/> -Y2412
	<input type="checkbox"/> -X2424	<input type="checkbox"/> -Y2424
	<input type="checkbox"/> -X2448	<input type="checkbox"/> -Y2448
	<input type="checkbox"/> -X4824	<input type="checkbox"/> -Y4824
	<input type="checkbox"/> -X2020	<input type="checkbox"/> -Y2020
	No fastening options available	

Finish				
<input type="checkbox"/> /W White (default)	<input type="checkbox"/> /B Brushed Aluminum	<input type="checkbox"/> /M Mill Finish	<input type="checkbox"/> /L Brushed & Lacquered	<input type="checkbox"/> /C Custom (Please Specify)



Schedule type: _____

Job: _____

Architect: _____

Engineer: _____

Contractor: _____

Double Deflection Supply Grille

Material: Extruded aluminum frame, roll-formed fins, some unapparent steel subcomponents.

Air Pattern: Adjustable Air Pattern

Horizontal Face Bars (Standard)

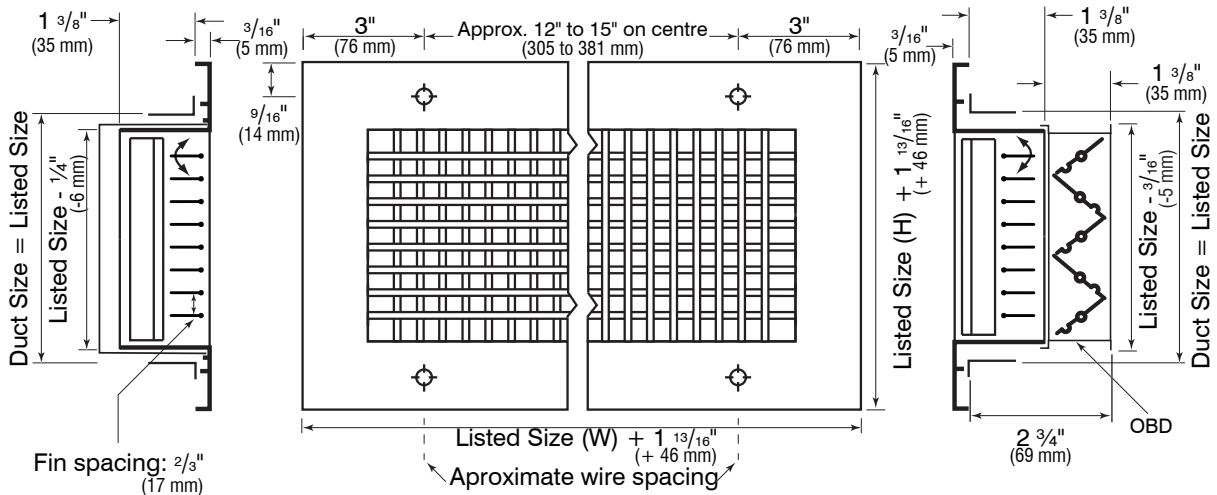
(Mullion required for w > 18")

- GSA20** Steel fins
- GSA27** Steel fins with OBD
- GAA20** Aluminum fins
- GAA27** Aluminum fins with OBD



Vertical Face Bars

- GSA20-V** Steel fins
- GSA27-V** Steel fins with OBD
- GAA20-V** Aluminum fins
- GAA27-V** Aluminum fins with OBD



Options		
-GK Flange Gasket	-GN Neck Gasket	-GR Rear Gasket
-SF Supplied w/ sub frame	-DS Debris (Bird) Screen	-IS Insect Screen

Fastening Method				
-1 No Fastening	-2 Spring clip	-3 Screw holes (Standard)	-4 Concealed	-6 Adhesive tape

Panel Option for T-bar lay-in Ceiling		
	Steel (WxH)	Aluminum (WxH)
	<input type="checkbox"/> -X1212	<input type="checkbox"/> -Y1212
	<input type="checkbox"/> -X1224	<input type="checkbox"/> -Y1224
	<input type="checkbox"/> -X2412	<input type="checkbox"/> -Y2412
	<input type="checkbox"/> -X2424	<input type="checkbox"/> -Y2424
	<input type="checkbox"/> -X2448	<input type="checkbox"/> -Y2448
	<input type="checkbox"/> -X4824	<input type="checkbox"/> -Y4824
	<input type="checkbox"/> -X2020	<input type="checkbox"/> -Y2020
	No fastening options available	

Finish				
<input type="checkbox"/> /W White (default)	<input type="checkbox"/> /B Brushed Aluminum	<input type="checkbox"/> /M Mill Finish	<input type="checkbox"/> /L Brushed & Lacquered	<input type="checkbox"/> /C Custom (Please Specify)



Schedule type: _____

Job: _____

Architect: _____

Engineer: _____

Contractor: _____

Fixed 45 degree Deflection Return Grille

Material: Extruded aluminum frame, roll-formed fins, some unapparent steel subcomponents.

Horizontal Face Bars (Standard)

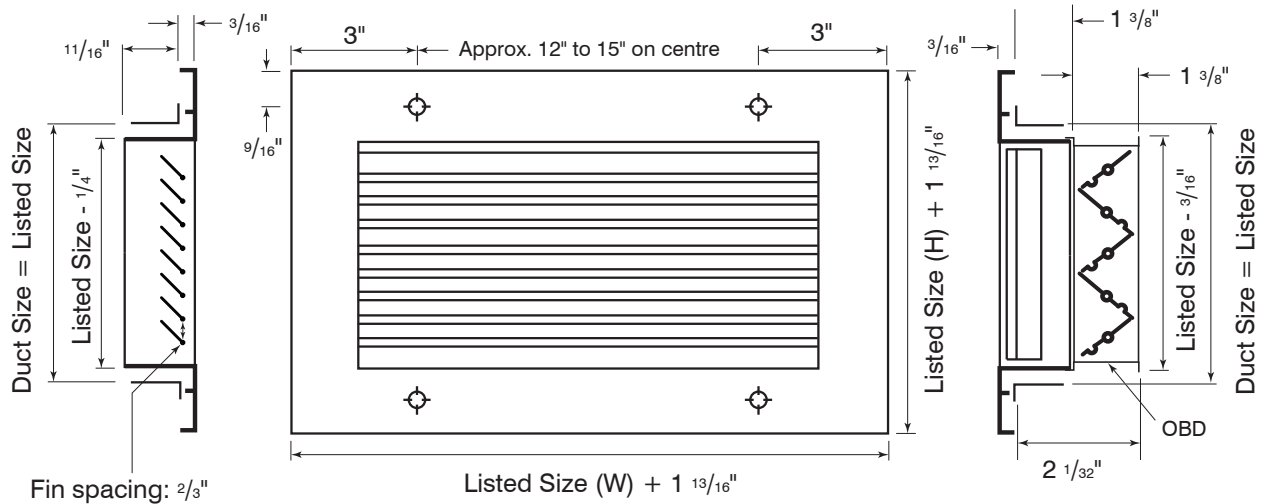
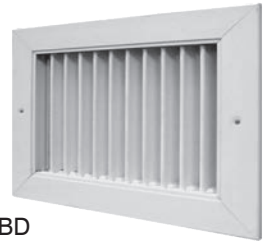
(Mullion required for w > 18")

- GSA40** Steel
- GSA47** Steel with OBD
- GAA40** Aluminum
- GAA47** Aluminum with OBD



Vertical Face Bars

- GSA40-V** Steel
- GSA47-V** Steel with OBD
- GAA40-V** Aluminum
- GAA47-V** Aluminum with OBD



Options		
<input type="checkbox"/> -GK Flange Gasket	<input type="checkbox"/> -GN Neck Gasket	<input type="checkbox"/> -GR Rear Gasket
<input type="checkbox"/> -SF Supplied w/ sub frame	<input type="checkbox"/> -DS Debris (Bird) Screen	<input type="checkbox"/> -IS Insect Screen

Options Ext.
<input type="checkbox"/> -EXT Reinforced for Outside

Fastening Method				
<input type="checkbox"/> -1 No Fastening	<input type="checkbox"/> -2 Spring clip	<input type="checkbox"/> -3 Screw holes (Standard)	<input type="checkbox"/> -4 Concealed	<input type="checkbox"/> -6 Adhesive tape

Panel Option for T-bar lay-in Ceiling		
	Steel (WxH)	Aluminum (WxH)
	<input type="checkbox"/> -X1212	<input type="checkbox"/> -Y1212
	<input type="checkbox"/> -X1224	<input type="checkbox"/> -Y1224
	<input type="checkbox"/> -X2412	<input type="checkbox"/> -Y2412
	<input type="checkbox"/> -X2424	<input type="checkbox"/> -Y2424
	<input type="checkbox"/> -X2448	<input type="checkbox"/> -Y2448
	<input type="checkbox"/> -X4824	<input type="checkbox"/> -Y4824
	<input type="checkbox"/> -X2020	<input type="checkbox"/> -Y2020
	No fastening options available	

Finish				
<input type="checkbox"/> /W White (default)	<input type="checkbox"/> /B Brushed Aluminum	<input type="checkbox"/> /M Mill Finish	<input type="checkbox"/> /L Brushed & Lacquered	<input type="checkbox"/> /C Custom (Please Specify)



Schedule type: _____

Job: _____

Architect: _____

Engineer: _____

Contractor: _____

Fixed 45 degree Deflection Return Grille

Material: Extruded aluminum frame, roll-formed fins, some unapparent steel subcomponents.

Horizontal Face Bars (Standard)

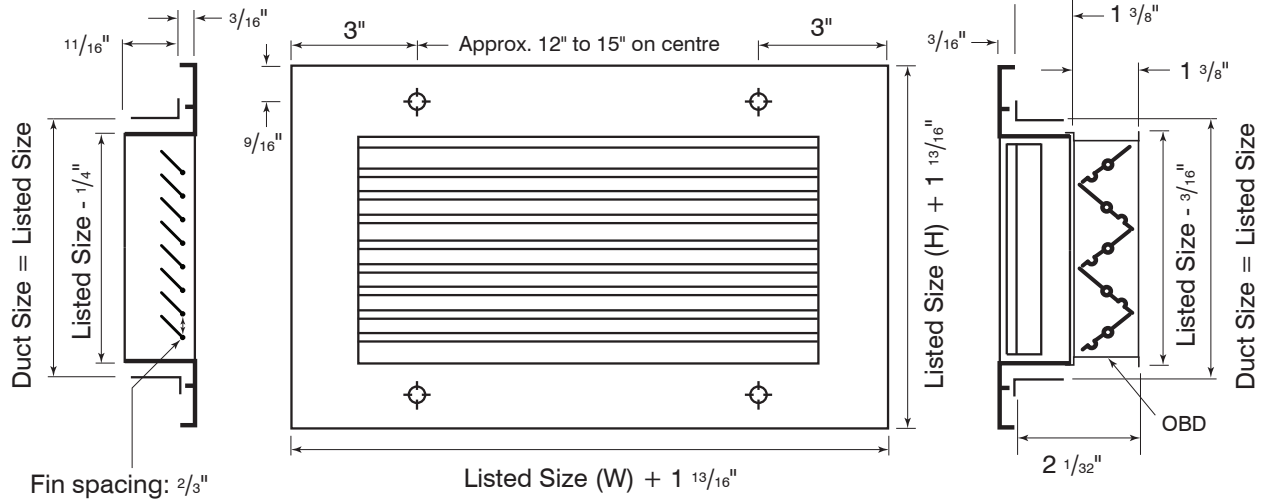
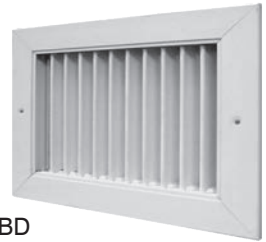
(Mullion required for w > 18")

- GSA40** Steel
- GSA47** Steel with OBD
- GAA40** Aluminum
- GAA47** Aluminum with OBD



Vertical Face Bars

- GSA40-V** Steel
- GSA47-V** Steel with OBD
- GAA40-V** Aluminum
- GAA47-V** Aluminum with OBD



Options			
-GK Flange Gasket	-GN Neck Gasket	-GR Rear Gasket	
-SF Supplied w/ sub frame	-DS Debris (Bird) Screen	-IS Insect Screen	-FB Fixed Blades 0 degrees

Options Ext.	Filter Options
-EXT Reinforced for Outside	-F0.5 0.5" Filter Add 0.5

Fastening Method				
-1 No Fastening	-2 Spring clip	-3 Screw holes (Standard)	-4 Concealed	-6 Adhesive tape tape

Panel Option for T-bar lay-in Ceiling		
	Steel (WxH)	Aluminum (WxH)
	<input type="checkbox"/> -X1212	<input type="checkbox"/> -Y1212
	<input type="checkbox"/> -X1224	<input type="checkbox"/> -Y1224
	<input type="checkbox"/> -X2412	<input type="checkbox"/> -Y2412
	<input type="checkbox"/> -X2424	<input type="checkbox"/> -Y2424
	<input type="checkbox"/> -X2448	<input type="checkbox"/> -Y2448
	<input type="checkbox"/> -X4824	<input type="checkbox"/> -Y4824
	<input type="checkbox"/> -X2020	<input type="checkbox"/> -Y2020
	No fastening options available	

Finish				
<input type="checkbox"/> /W White (default)	<input type="checkbox"/> /B Brushed Aluminum	<input type="checkbox"/> /M Mill Finish	<input type="checkbox"/> /L Brushed & Lacquered	<input type="checkbox"/> /C Custom (Please Specify)



Schedule type: _____

Job: _____

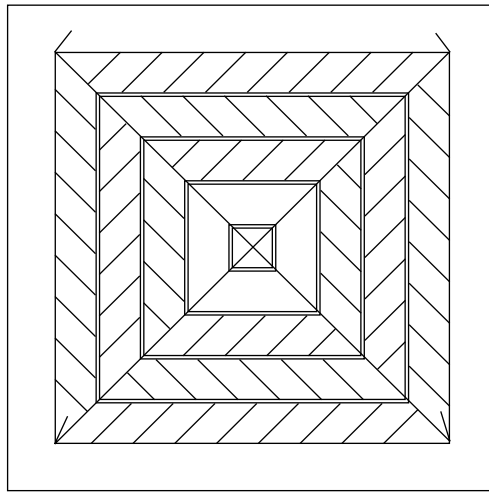
Architect: _____

Engineer: _____

Contractor: _____

High Induction Vanes

Material: Aluminum vanes crimped on the back of the diffuser's face.
Pushes air in alternate centrifugal directions to create induction.
Promotes rapid mixing of room air and supply air.



Finish		
<input type="checkbox"/> /W White <small>(default)</small>	<input type="checkbox"/> /M Mill	<input type="checkbox"/> /C Custom _____ <small>(please specify)</small>

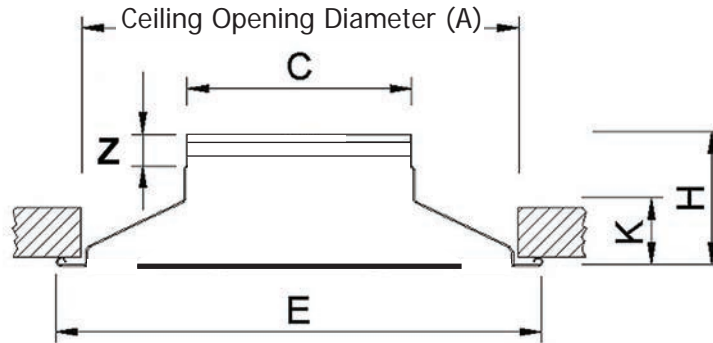
Schedule type: _____
Job: _____
Architect: _____
Engineer: _____
Contractor: _____

High Ceiling Round Diffuser Spun Aluminum

Material: Heavy gauge spun aluminum.
Finish: Powder paint coating - white.
Air Pattern: 360° diffusion, vertically adjustable.
Mounting: Surface or open ceiling.


ICG

SUBMITTAL SHEET



Model	Duct Size	A (in)	C (in)	E (in)	H (in)	K (in)	Z (in)
ICG 06	6"	11 59/64	5 3/4	13 5/16	4 15/16	1 47/64	1
ICG 08	8"	15 5/32	7 3/4	16 47/64	4 17/32	2 9/32	1
ICG 10	10"	18 17/64	9 3/4	19 3/8	4 31/64	2 1/4	1
ICG 12	12"	22 13/64	11 3/4	23 17/64	6 19/32	3 5/32	1
ICG 14	14"	24 13/16	13 29/32	26 1/16	5 33/64	3 17/64	1
ICG 16	16"	24 13/16	15 43/64	26 1/16	5 5/32	2 59/64	1
ICG 18	18"	31 7/32	17 19/32	32 3/4	6 13/16	4 11/64	1
ICG 20	20"	31 7/32	19 9/16	32 3/4	6 27/64	3 13/16	1

Finish	
<input type="checkbox"/> /W White (Default)	<input type="checkbox"/> /C Custom _____ (Please Specify)



Schedule type: _____
Job: _____
Architect: _____
Engineer: _____
Contractor: _____

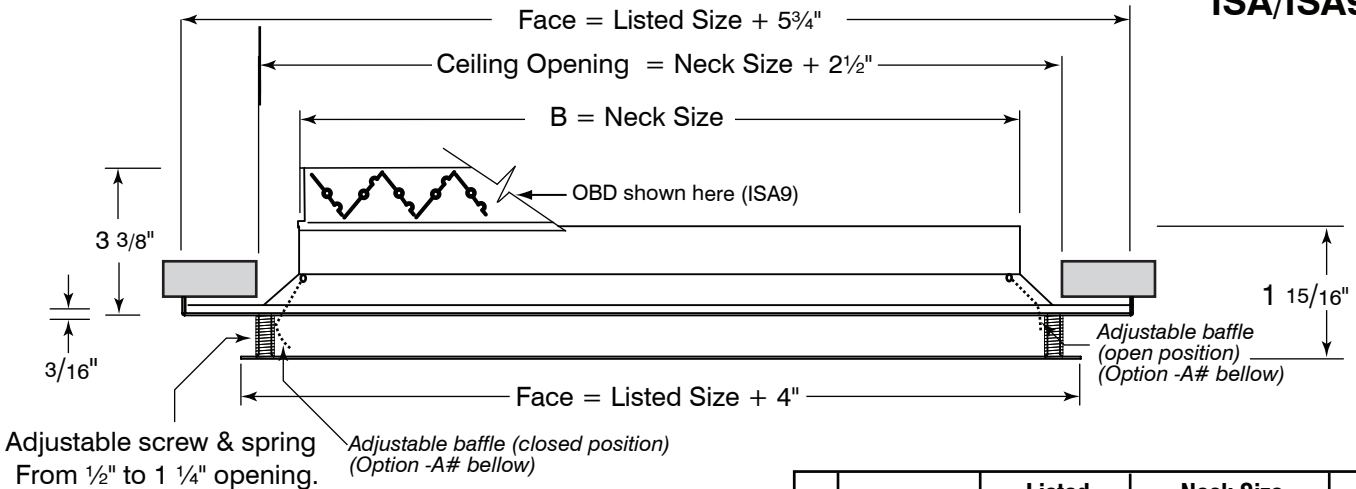
SUBMITTAL SHEET

Ceiling Diffuser - Adjustable Plaque Diffusers Directional Fixed Air Pattern - Square Neck

- Material:** Heavy gauge aluminum.
- Finish:** Powder paint coating - white.
- Mounting:** Surface or Lay-in T-bar ceiling.
- Volume Control:** Available with pre-installed aluminum OBD (Model# ISA9).

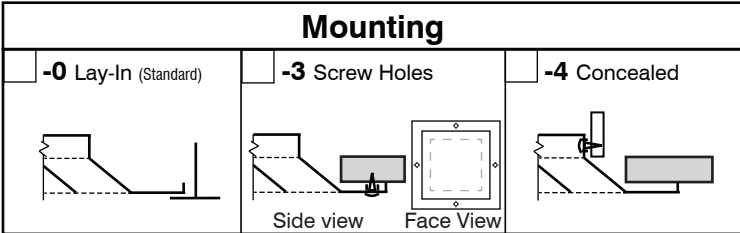
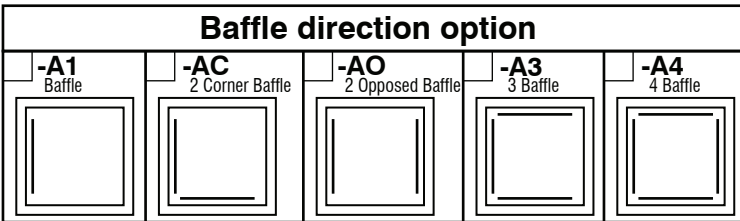


ISA/ISA9



Adjustable screw & spring
From 1/2" to 1 1/4" opening.

Adjustable baffle (closed position)
(Option -A# below)



Panel Option for T-bar lay-in Ceiling

	Steel (WxH)	Aluminum (WxH)
	<input type="checkbox"/> -X2412	<input type="checkbox"/> -Y2412
	<input type="checkbox"/> -X2424	<input type="checkbox"/> -Y2424
	<input type="checkbox"/> -X4812	<input type="checkbox"/> -Y4812
	<input type="checkbox"/> -X4824	<input type="checkbox"/> -Y4824
	<input type="checkbox"/> -X2020	<input type="checkbox"/> -Y2020

No mounting options available

✓	Model #	Listed Size	Neck Size B	Face Size
	ISA 0606	6" x 6"	5 15/16" x 5 15/16"	11 3/4" x 11 3/4"
	ISA 0909	9" x 9"	8 15/16" x 8 15/16"	14 3/4" x 14 3/4"
	ISA 1212	12" x 12"	11 15/16" x 11 15/16"	17 3/4" x 17 3/4"
	ISA 1515	15" x 15"	15 15/16" x 15 15/16"	20 3/4" x 20 3/4"
	ISA 1818	18" x 18"	18 15/16" x 18 15/16"	23 3/4" x 23 3/4"
	ISA9 0606	6" x 6"	6 3/16" x 6 3/16"	11 3/4" x 11 3/4"
	ISA9 0909	9" x 9"	9 3/16" x 9 3/16"	14 3/4" x 14 3/4"
	ISA9 1212	12" x 12"	12 3/16" x 12 3/16"	17 3/4" x 17 3/4"
	ISA9 1515	15" x 15"	15 3/16" x 15 3/16"	20 3/4" x 20 3/4"
	ISA9 1818	18" x 18"	18 3/16" x 18 3/16"	23 3/4" x 23 3/4"

Finish

<input type="checkbox"/> /W White (Default)	<input type="checkbox"/> /C Custom (Please Specify)
---	---



Schedule type: _____

Job: _____

Architect: _____

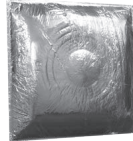
Engineer: _____

Contractor: _____

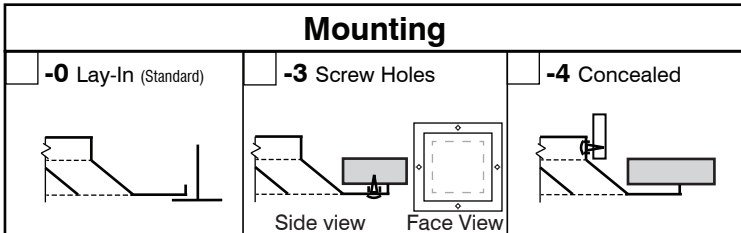
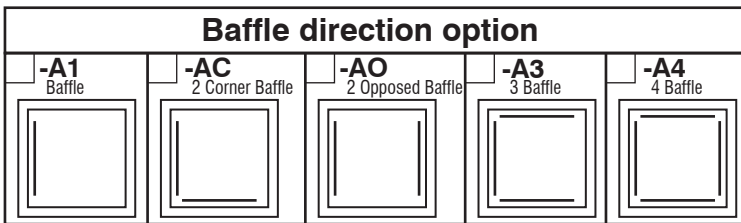
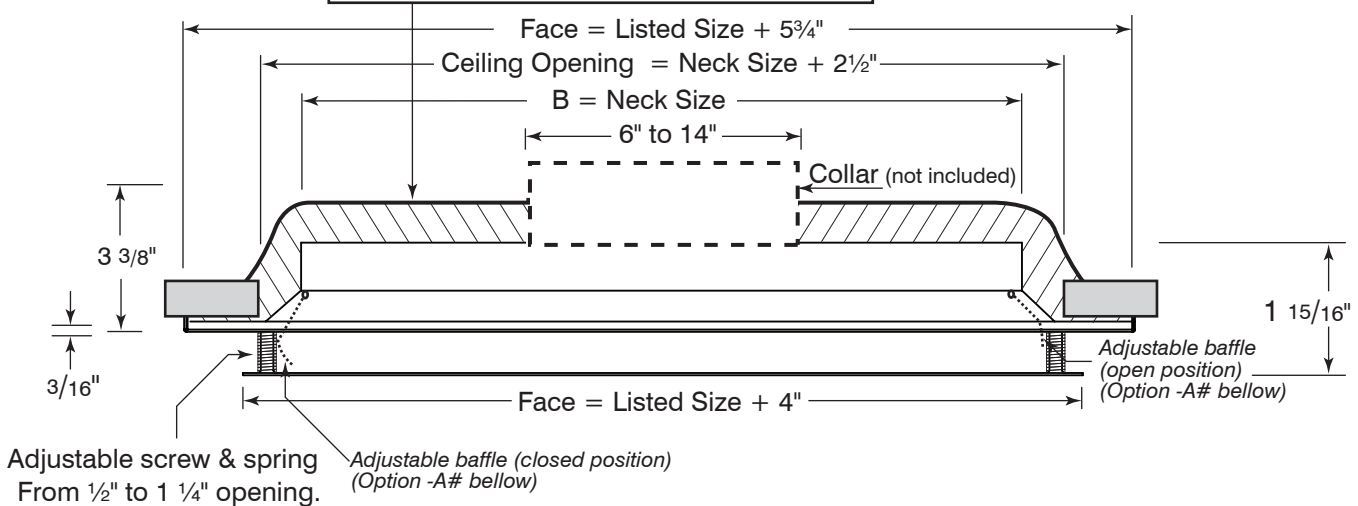
Ceiling Diffuser - Adjustable Plaque Diffusers Directional Fixed Air Pattern, Square Neck, Insulated Back

Material: Heavy gauge aluminum.
Finish: Powder paint coating - white.
Mounting: Surface or Lay-in T-bar ceiling.

R6 fiberglass back complies with A.S.T.M. E84 flame and smoke test.
 Scored for collar sizes up to 14" D.
 Contractor to install job-specific collar in field.



ISAI



Panel Option for T-bar lay-in Ceiling

	Steel (WxH)	Aluminum (WxH)
	<input type="checkbox"/> -X2412	<input type="checkbox"/> -Y2412
	<input type="checkbox"/> -X2424	<input type="checkbox"/> -Y2424
	<input type="checkbox"/> -X4812	<input type="checkbox"/> -Y4812
	<input type="checkbox"/> -X4824	<input type="checkbox"/> -Y4824
	<input type="checkbox"/> -X2020	<input type="checkbox"/> -Y2020

No mounting options available

Model #	Listed Size	Neck Size B x B	Face Size
ISAI 1818	18" x 18"	18 3/16" x 18 3/16"	23 3/4" x 23 3/4"

Finish

<input type="checkbox"/> /W White (Default)	<input type="checkbox"/> /C Custom (Please Specify)
---	---



Schedule type: _____
 Job: _____
 Architect: _____
 Engineer: _____
 Contractor: _____

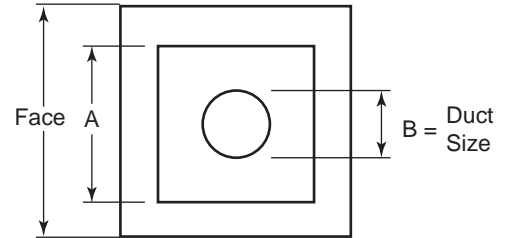
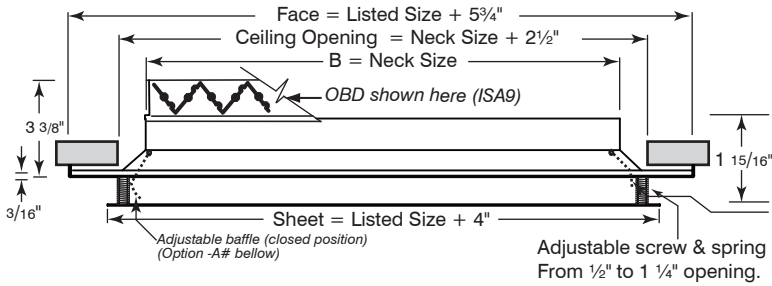
SUBMITTAL SHEET

Ceiling Diffuser - Adjustable Plaque Diffusers Directional Fixed Air Pattern - Round Neck

- Material:** Heavy gauge aluminum.
Finish: Powder paint coating - white.
Mounting: Surface or Lay-in T-bar ceiling.
Volume Control: Available with pre-installed opposed blade damper (Model# ISAM4) or radial sliding blade damper (Model# ISAM5).



ISAM

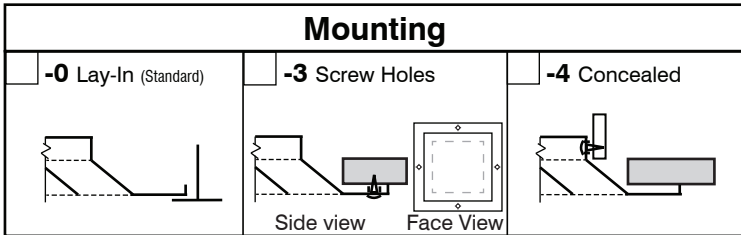
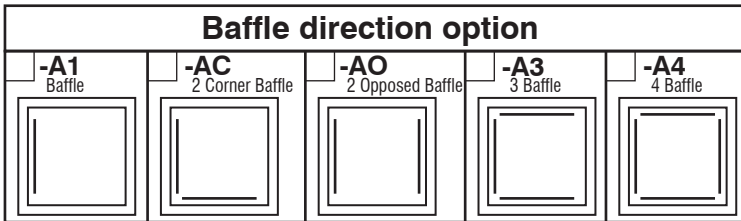


- ISAM** No Damper
- ISAM4** Pre-Installed N4 Opposed Blade Damper
- ISAM5** Pre-Installed N5 Radial Sliding Blade Damper

Adjustable baffle (open position) (Option -A# below)

✓ Model #	A	B	Neck Size	Face Size
0606 06	6 x 6	6	5 7/8	11 3/4 x 11 3/4
0909 06	9 x 9	6	5 7/8	14 3/4 x 14 3/4
0909 08	9 x 9	8	7 7/8	14 3/4 x 14 3/4
1212 06	12 x 12	6	5 7/8	17 3/4 x 17 3/4
1212 08	12 x 12	8	7 7/8	17 3/4 x 17 3/4
1212 10	12 x 12	10	9 7/8	17 3/4 x 17 3/4
1212 12	12 x 12	12	11 7/8	17 3/4 x 17 3/4
1515 06	15 x 15	6	5 7/8	20 3/4 x 20 3/4
1515 08	15 x 15	8	7 7/8	20 3/4 x 20 3/4
1515 10	15 x 15	10	9 7/8	20 3/4 x 20 3/4
1515 12	15 x 15	12	11 7/8	20 3/4 x 20 3/4
1515 14 ¹	15 x 15	14	13 7/8	20 3/4 x 20 3/4
1818 06	18 x 18	6	5 7/8	23 3/4 x 23 3/4
1818 08	18 x 18	8	7 7/8	23 3/4 x 23 3/4
1818 10	18 x 18	10	9 7/8	23 3/4 x 23 3/4
1818 12	18 x 18	12	11 7/8	23 3/4 x 23 3/4
1818 14 ¹	18 x 18	14	13 7/8	23 3/4 x 23 3/4
1818 16 ²	18 x 18	16	15 7/8	23 3/4 x 23 3/4

¹ Size not available for DLAM5 ² Size not available for DLAM4 and DLAM5



Panel Option for T-bar lay-in Ceiling

	Steel (WxH)	Aluminum (WxH)
	<input type="checkbox"/> -X2412	<input type="checkbox"/> -Y2412
	<input type="checkbox"/> -X2424	<input type="checkbox"/> -Y2424
	<input type="checkbox"/> -X4812	<input type="checkbox"/> -Y4812
	<input type="checkbox"/> -X4824	<input type="checkbox"/> -Y4824
	<input type="checkbox"/> -X2020	<input type="checkbox"/> -Y2020
	No mounting options available	

Finish

/W White (Default) /C Custom (Please Specify)



Schedule type: _____

Job: _____

Architect: _____

Engineer: _____

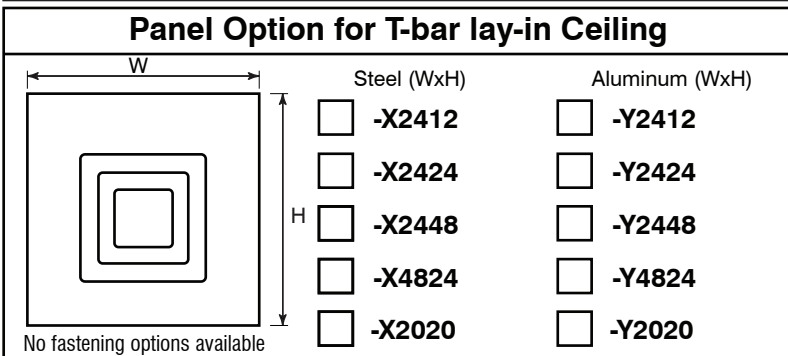
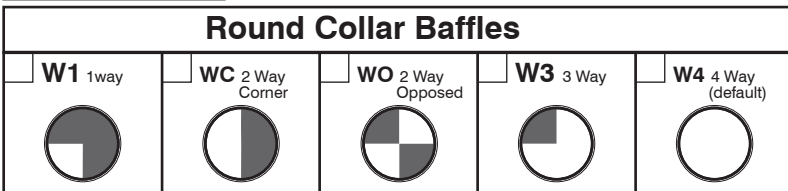
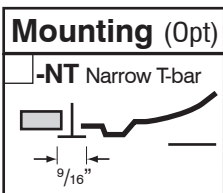
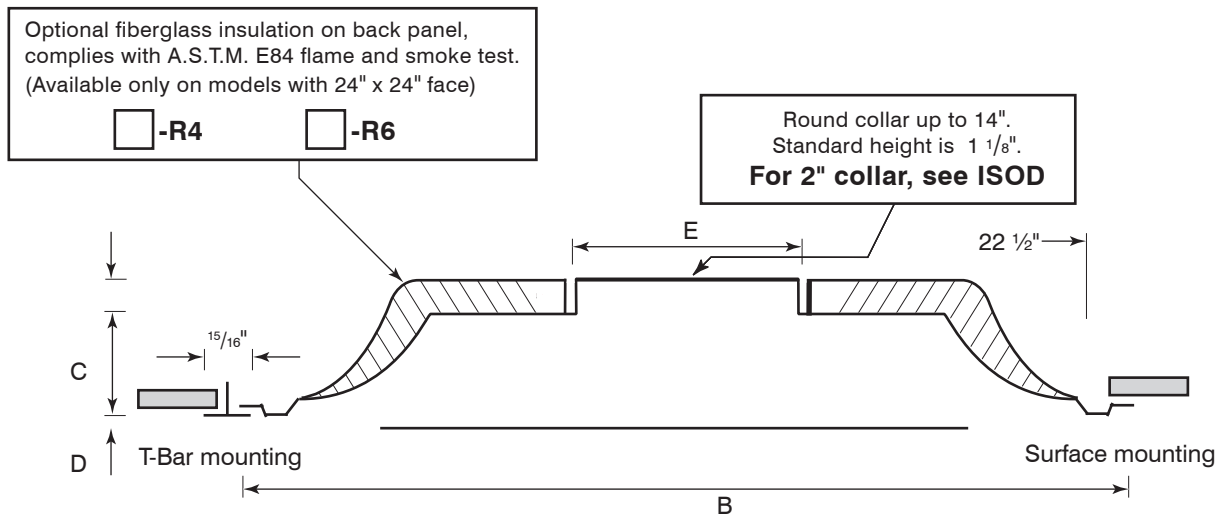
Contractor: _____

Square Plaque Diffuser - Architectural Line

- Material:** Stamped heavy gauge steel.
Finish: Powder paint coating - white.
Mounting: Surface or Lay-in T-bar ceiling.
Air Pattern: Fixed horizontal 360° diffusion.
Safety: Seismic tabs.
Core Removal: Unlock hanger brackets by swiveling lever down. Holding core panel at opposite sides, push upwards, then turn clockwise and drop core free from back plenum.


ISO

SUBMITTAL SHEET



✓	Model #	Duct Size	E	Face Dim B x B	C	D
	ISO 1206	6	5 7/8"	11 3/4" x 11 3/4"	1 3/4"	7/16"
	ISO 1208	8	7 7/8"	11 3/4" x 11 3/4"	1 3/4"	7/16"
	ISO 2406	6	5 7/8"	23 3/4" x 23 3/4"	2 7/8"	7/8"
	ISO 2408	8	7 7/8"	23 3/4" x 23 3/4"	2 7/8"	7/8"
	ISO 2410	10	9 7/8"	23 3/4" x 23 3/4"	2 7/8"	7/8"
	ISO 2412	12	11 7/8"	23 3/4" x 23 3/4"	2 7/8"	7/8"
	ISO 2414	14	13 7/8"	23 3/4" x 23 3/4"	2 7/8"	7/8"

Finish

/W White (Default) /C Custom (Please Specify)



Schedule type: _____
 Job: _____
 Architect: _____
 Engineer: _____
 Contractor: _____

SUBMITTAL SHEET

Square Plaque Diffuser - Architectural Line 2" High Collar, Individual Packaging

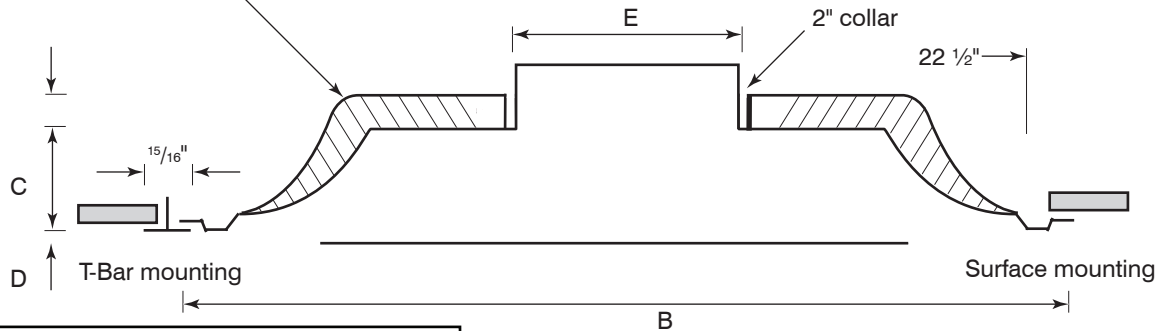
- Material:** Stamped heavy gauge steel.
- Finish:** Powder paint coating - white.
- Mounting:** Surface or Lay-in T-bar ceiling.
- Air Pattern:** Fixed horizontal 360° diffusion.
- Safety:** Seismic tabs.
- Core Removal:** Unlock hanger brackets by swiveling lever down. Holding core panel at opposite sides, push upwards, then turn clockwise and drop core free from back plenum.



ISOD
Aluminum

Optional fiberglass insulation on back panel, complies with A.S.T.M. E84 flame and smoke test. (Available only on models with 24" x 24" face)

- R4 -R6



Mounting (Opt)

-NT Narrow T-bar

Round Collar Baffles

W1 1 Way **WC** 2 Way Corner **WO** 2 Way Opposed **W3** 3 Way **W4** 4 Way (default)

Panel Option for T-bar lay-in Ceiling

Steel (WxH)	Aluminum (WxH)
<input type="checkbox"/> -X2412	<input type="checkbox"/> -Y2412
<input type="checkbox"/> -X2424	<input type="checkbox"/> -Y2424
<input type="checkbox"/> -X2448	<input type="checkbox"/> -Y2448
<input type="checkbox"/> -X4824	<input type="checkbox"/> -Y4824
<input type="checkbox"/> -X2020	<input type="checkbox"/> -Y2020

No fastening options available

✓	Model #	Duct Size	E	Face Dim B x B	C	D
	ISOD 1206	6	5 7/8"	11 3/4" x 11 3/4"	1 3/4"	7/16"
	ISOD 1208	8	7 7/8"	11 3/4" x 11 3/4"	1 3/4"	7/16"
	ISOD 2406	6	5 7/8"	23 3/4" x 23 3/4"	2 7/8"	7/8"
	ISOD 2408	8	7 7/8"	23 3/4" x 23 3/4"	2 7/8"	7/8"
	ISOD 2410	10	9 7/8"	23 3/4" x 23 3/4"	2 7/8"	7/8"
	ISOD 2412	12	11 7/8"	23 3/4" x 23 3/4"	2 7/8"	7/8"
	ISOD 2414	14	13 7/8"	23 3/4" x 23 3/4"	2 7/8"	7/8"

Finish

/W White (Default) /C Custom (Please Specify)



<p>Equalizing Grid (Option)</p> <p>Refer to NEG</p>	<p>Damper (Option)</p> <p>Refer to N4 Refer to N5</p> <p>Opposed Blade Sliding Blade</p>		<p>Plaster Frame (Option)</p> <p>Refer to PF</p>
--	---	--	---

Schedule type: _____

Job: _____

Architect: _____

Engineer: _____

Contractor: _____

Square Plaque Diffuser - Architectural Line Insulated, One Size Fits All

- Material:** Stamped heavy gauge steel.
- Finish:** Powder paint coating - white.
- Mounting:** Lay-in T-bar ceiling.
- Air Pattern:** Fixed horizontal 360° diffusion.
- Safety:** Seismic tabs.
- Core Removal:** Unlock hanger brackets by swiveling lever down. Holding core panel at opposite sides, push upwards, then turn clockwise and drop core free from back plenum.

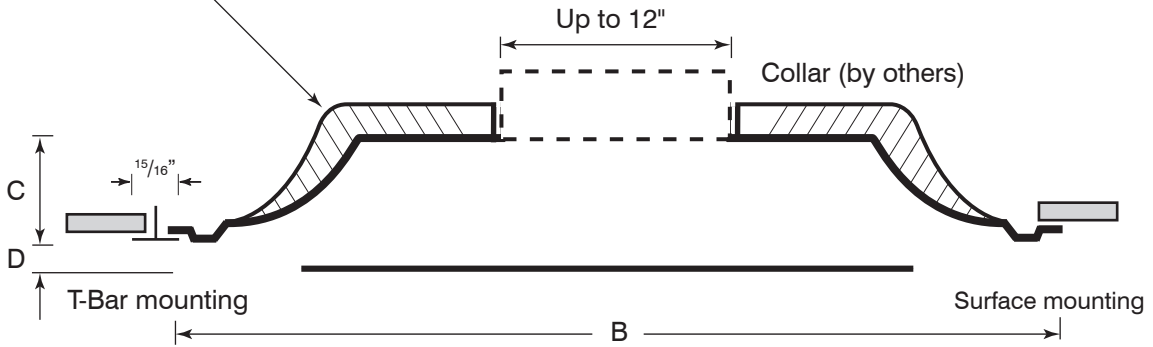


ISOI

SUBMITTAL SHEET

R6 fiberglass back complies with A.S.T.M. E84 flame and smoke test.

Scored for collar sizes up to 12" D. Contractor to install job-specific collar in field. For size 14", please refer to model ISO-R6 2414.



Model #	Face Dim B x B	C	D
AISOI	23 3/4" X 23 3/4"	2 7/8"	7/8"

Finish	
<input type="checkbox"/> /W White (Default)	<input type="checkbox"/> /C Custom (Please Specify)



Schedule type: _____

Job: _____

Architect: _____

Engineer: _____

Contractor: _____

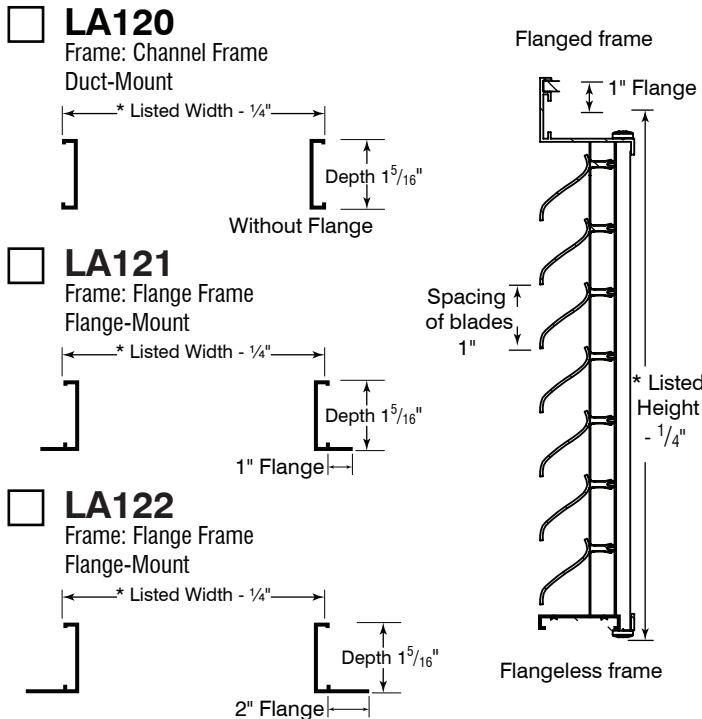
1" Stormproof Louver

Standard Construction

- Material** Extruded Aluminum - 6063- T5 Alloy.
- Frame thickness** 0.062" (1.57 mm).
- Blade thickness** 0.062" (1.57 mm).
- Blade angle** 45°.
- Blade spacing** 1" (25 mm).
- Depth** 1⁵/₁₆" (33 mm).
- Finish** Mill.




LA12



One-Piece Louver Dimensions		
	Min.	Max.
Area	0.67 ft ² (0.06 m ²)	36 ft ² (3.34 m ²)
Width	10" (254 mm)	72" (1829 mm)
Height	6" (152 mm)	72" (1829 mm)

* Louver dimensions are undercut 1/4" (6.4 mm) for single sections and undercut 1/2" (12.7 mm) for multiple sections unless otherwise specified.

Options

Screen options	
<input type="checkbox"/>	-DS 19 Ga Birdscreen - 1/2" x 1/2" Openings (Default)
<input type="checkbox"/>	-DSA 14 Ga Inter Crimped Aluminum Birdscreen - 1/2" x 1/2"
<input type="checkbox"/>	-DSF Aluminum Birdscreen With 1" Frame
<input type="checkbox"/>	-IS Insect Screen (18 x 14 Mesh )

Blank-off Panels (Aluminum)	
<input type="checkbox"/>	-BP0 Blank-off Panel (Non-Insulated)
<input type="checkbox"/>	-BP1 1" Blank-off Panel (25.4 mm) (Insulated)
<input type="checkbox"/>	-BP2 2" Blank-off Panel (50.8 mm)

Filter Holder Options	
<input type="checkbox"/>	-F1 Filter Holder 1" Deep
<input type="checkbox"/>	-F2 Filter Holder 2" Deep

Other Options	
<input type="checkbox"/>	-ES Extended Sills 14 Ga Aluminum
<input type="checkbox"/>	-SG Security Grilles
<input type="checkbox"/>	-NS Welded Construction (no screws)
<input type="checkbox"/>	-HM Hidden Mullions

Finish

- /M Mill finish (default)
- /DR Duranar Finish
- /DN Duracron Finish
- /C# (# = A,B,C, or D see RAL Chart) RAL Code: _____ (Please Specify)
- /CL Custom Baked Enamel Liquid Paint Match
- /CP Custom Powder Paint Match
- /A Clear Anodized
- /AL Light Bronze Anodized
- /AM Medium Bronze Anodized
- /AD Dark Bronze Anodized
- /AB Black Anodized



Schedule type: _____

Job: _____

Architect: _____

Engineer: _____

Contractor: _____

2" Stormproof Louver

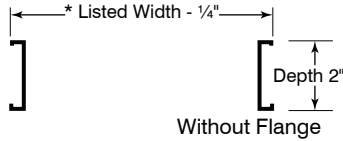
Standard Construction

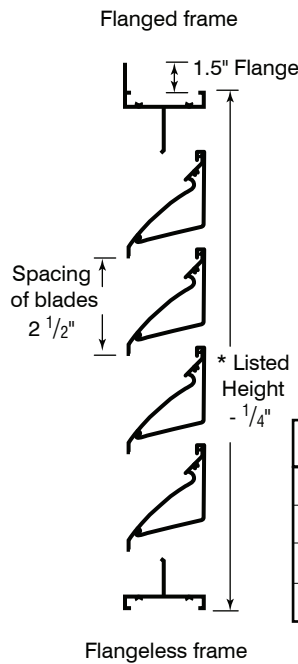
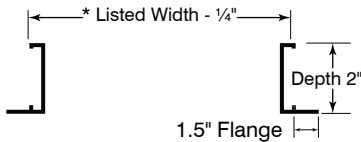
Material	Extruded Aluminum - 6063- T5 Alloy.
Frame thickness	0.062" (1.57 mm).
Blade thickness	0.062" (1.57 mm).
Blade angle	45°.
Blade spacing	2.5" (64 mm).
Depth	2" (51 mm).
Finish	Mill.


LA22

SUBMITTAL SHEET

 LA220

 Frame: Channel Frame
 Duct-Mount

 LA225

 Frame: Flange Frame
 Flange-Mount


One-Piece Louver Dimensions		
	Min.	Max.
Area	0.67 ft ² (0.06 m ²)	36 ft ² (3.34 m ²)
Width	12" (305 mm)	72" (1829 mm)
Height	8" (203 mm)	72" (1829 mm)

* Louver dimensions are undercut 1/4" (6.4 mm) for single sections and undercut 1/2" (12.7 mm) for multiple sections unless otherwise specified.

Options

Screen options

- DS** 19 Ga Birdscreen - 1/2" x 1/2" Openings (Default)
- DSA** 14 Ga Inter Crimped Aluminum Birdscreen - 1/2" x 1/2"
- DSF** Aluminum Birdscreen With 1" Frame
- IS** Insect Screen 18 x 14 Mesh

Blank-off Panels (Aluminum)

- BP0** Blank-off Panel (Non-Insulated)
- BP1** 1" Blank-off Panel (25.4 mm) (Insulated)
- BP2** 2" Blank-off Panel (50.8 mm)

Filter Holder Options

- F1** Filter Holder 1" Deep
- F2** Filter Holder 2" Deep

Other Options

- ES** Extended Sills 14 Ga Aluminum
- SG** Security Grilles
- NS** Welded Construction (no screws)
- HM** Hidden Mullions

Finish

- /M** Mill finish (default)
- /DR** Duranar Finish
- /DN** Duracron Finish
- /C#** (# = A,B,C, or D see RAL Chart) RAL Code: _____ (Please Specify)
- /CL** Custom Baked Enamel Liquid Paint Match
- /CP** Custom Powder Paint Match
- /A** Clear Anodized
- /AL** Light Bronze Anodized
- /AM** Medium Bronze Anodized
- /AD** Dark Bronze Anodized
- /AB** Black Anodized



Schedule type: _____

Job: _____

Architect: _____

Engineer: _____

Contractor: _____

4" Stormproof Louver

Standard Construction

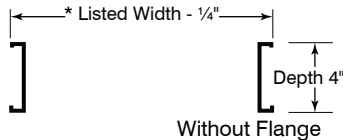
- Material** Extruded Aluminum - 6063- T5 Alloy.
- Frame thickness** 0.062" (1.57 mm).
- Blade thickness** 0.062" (1.57 mm).
- Blade angle** 45°.
- Blade spacing** 4.5" (114 mm).
- Depth** 4" (107 mm).
- Finish** Mill.



LA42

LA420

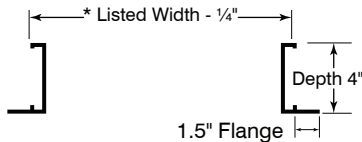
Frame: Channel Frame
Duct-Mount



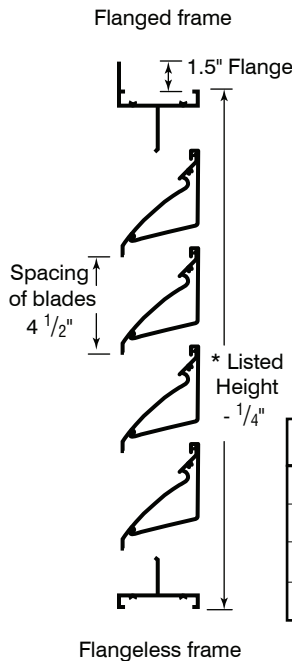
Without Flange

LA425

Frame: Flange Frame
Flange-Mount



1.5" Flange



One-Piece Louver Dimensions		
	Min.	Max.
Area	0.67 ft ² (0.06 m ²)	36 ft ² (3.34 m ²)
Width	12" (305 mm)	120" (3048 mm)
Height	12" (305 mm)	120" (3048 mm)

* Louver dimensions are undercut 1/4" (6.4 mm) for single sections and undercut 1/2" (12.7 mm) for multiple sections unless otherwise specified.

Options

Screen options

- DS** 19 Ga Birdscreen - 1/2" x 1/2" Openings (Default)
- DSA** 14 Ga Inter Crimped Aluminum Birdscreen - 1/2" x 1/2"
- DSF** Aluminum Birdscreen With 1" Frame
- IS** Insect Screen 18 x 14 Mesh

Blank-off Panels (Aluminum)

- BP0** Blank-off Panel (Non-Insulated)
- BP1** 1" Blank-off Panel (25.4 mm) (Insulated)
- BP2** 2" Blank-off Panel (50.8 mm)

Filter Holder Options

- F1** Filter Holder 1" Deep
- F2** Filter Holder 2" Deep

Other Options

- ES** Extended Sills 14 Ga Aluminum
- SG** Security Grilles
- NS** Welded Construction (no screws)
- HM** Hidden Mullions

Finish

- /M** Mill finish (default)
- /DR** Duranar Finish
- /DN** Duracron Finish
- /C#** (# = A,B,C, or D see RAL Chart) RAL Code: _____ (Please Specify)
- /CL** Custom Baked Enamel Liquid Paint Match
- /CP** Custom Powder Paint Match
- /A** Clear Anodized
- /AL** Light Bronze Anodized
- /AM** Medium Bronze Anodized
- /AD** Dark Bronze Anodized
- /AB** Black Anodized



Schedule type: _____

Job: _____

Architect: _____

Engineer: _____

Contractor: _____

6" Stormproof Louver

Standard Construction

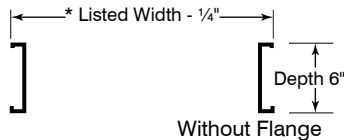
Material Extruded Aluminum - 6063- T5 Alloy.
Frame thickness 0.062" (1.57 mm).
Blade thickness 0.062" (1.57 mm).
Blade angle 45°.
Blade spacing 6.5" (165 mm).
Depth 6" (152 mm).
Finish Mill.


LA62

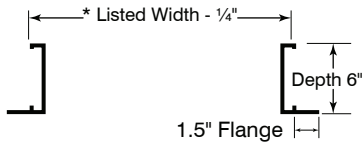
SUBMITTAL SHEET

 LA620

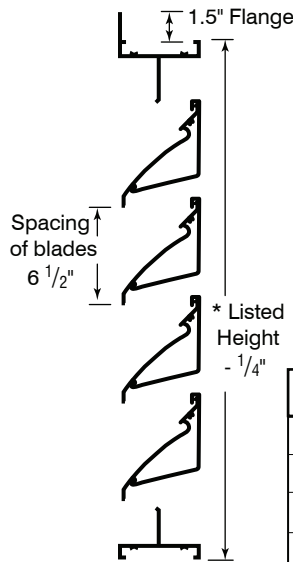
Frame: Channel Frame
Duct-Mount


 LA625

Frame: Flange Frame
Flange-Mount



Flanged frame



Flangeless frame

One-Piece Louver Dimensions		
	Min.	Max.
Area	0.67 ft ² (0.06 m ²)	36 ft ² (3.34 m ²)
Width	12" (305 mm)	120" (3048 mm)
Height	16" (406 mm)	120" (3048 mm)

* Louver dimensions are undercut 1/4" (6.4 mm) for single sections and undercut 1/2" (12.7 mm) for multiple sections unless otherwise specified.

Options

Screen options

- DS** 19 Ga Birdscreen - 1/2" x 1/2" Openings (Default)
- DSA** 14 Ga Inter Crimped Aluminum Birdscreen - 1/2" x 1/2"
- DSF** Aluminum Birdscreen With 1" Frame
- IS** Insect Screen 18 x 14 Mesh

Blank-off Panels (Aluminum)

- BP0** Blank-off Panel (Non-Insulated)
- BP1** 1" Blank-off Panel (25.4 mm) (Insulated)
- BP2** 2" Blank-off Panel (50.8 mm)

Filter Holder Options

- F1** Filter Holder 1" Deep
- F2** Filter Holder 2" Deep

Other Options

- ES** Extended Sills 14 Ga Aluminum
- SG** Security Grilles
- NS** Welded Construction (no screws)
- HM** Hidden Mullions

Finish

- /M** Mill finish (default)
- /DR** Duranar Finish
- /DN** Duracron Finish
- /C#** (# = A,B,C, or D see RAL Chart) RAL Code: _____ (Please Specify)
- /CL** Custom Baked Enamel Liquid Paint Match
- /CP** Custom Powder Paint Match
- /A** Clear Anodized
- /AL** Light Bronze Anodized
- /AM** Medium Bronze Anodized
- /AD** Dark Bronze Anodized
- /AB** Black Anodized



Schedule type: _____

Job: _____

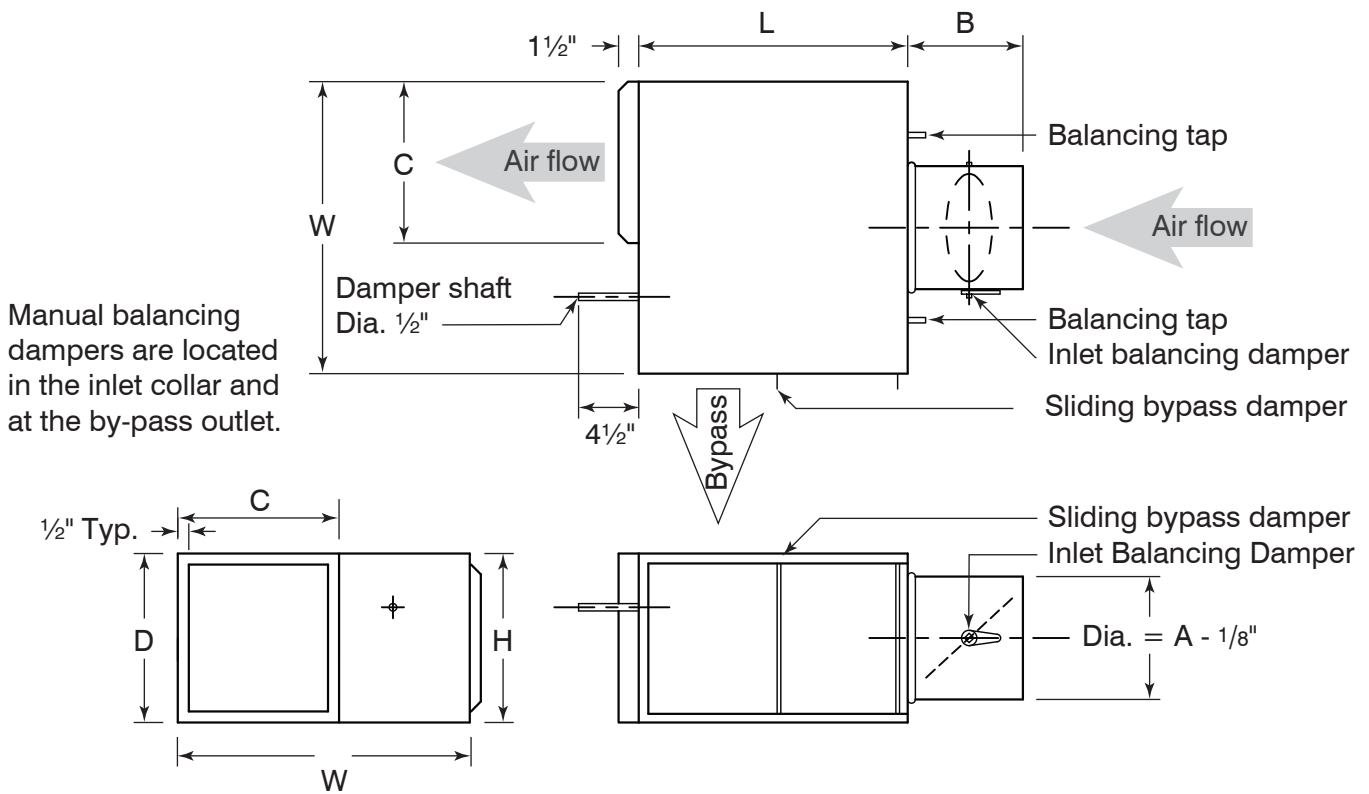
Architect: _____

Engineer: _____

Contractor: _____

Low Pressure Bypass Terminal Unit

Material: 22 gauge zinc-coated steel casing
internal insulation - fiberglass 1½" thick, min. 1.5# density



✓	Model #	Unit Size	W	L	H	Inlet		Outlet	
						A	B	C	D
	LPB 06	06"	17"	17"	10"	6"	9¼"	9"	10"
	LPB 08	08"	17"	17"	10"	8"	9¼"	9"	10"
	LPB 10	10"	25"	25"	14"	10"	11⅝"	13"	14"
	LPB 12	12"	25"	25"	14"	12"	11⅝"	13"	14"
	LPB 14	14"	29"	29"	16"	14"	14¼"	15"	16"
	LPB 16	16"	33"	33"	18"	16"	15⅝"	17"	18"

Schedule type: _____

Job: _____

Architect: _____

Engineer: _____

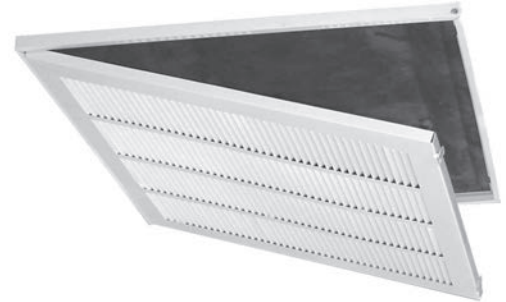
Contractor: _____

Lanced Face Filter Return with Molded Fiberglass Back Panel Hinged face

Material: Molded fiberglass back with aluminum foil vapor barrier scored for 6" to 14" D. in an extruded aluminum fixed frame. Steel lanced face with 1/2" spaced fins set at 40o swings in and out of fixed frame, for access to 20"x20" filter, by others.

Finish: Powder paint coating - white.

Mounting: T-bar Lay-in ceiling.

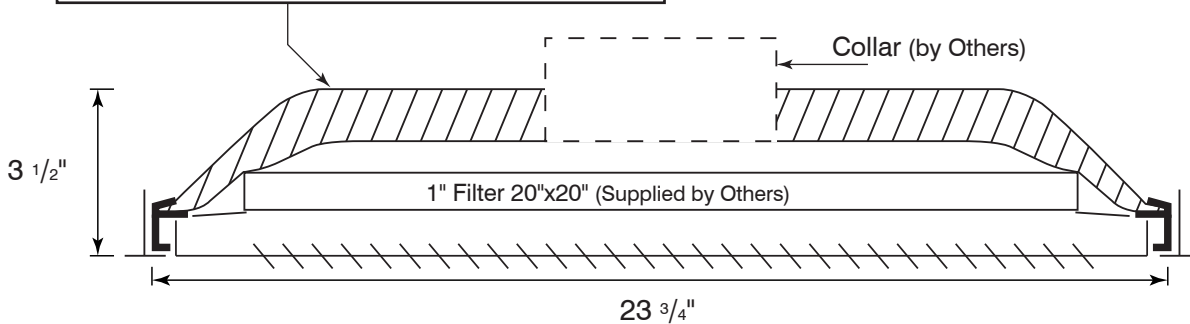


SUBMITTAL SHEET

LRIF

Fiberglass back complies with A.S.T.M. E84 flame and smoke test. Scored for collar sizes up to 14" D.

-R4 -R6



Finish	
<input type="checkbox"/> /W White (Default)	<input type="checkbox"/> /C Custom (Please Specify) _____



Schedule type: _____

Job: _____

Architect: _____

Engineer: _____

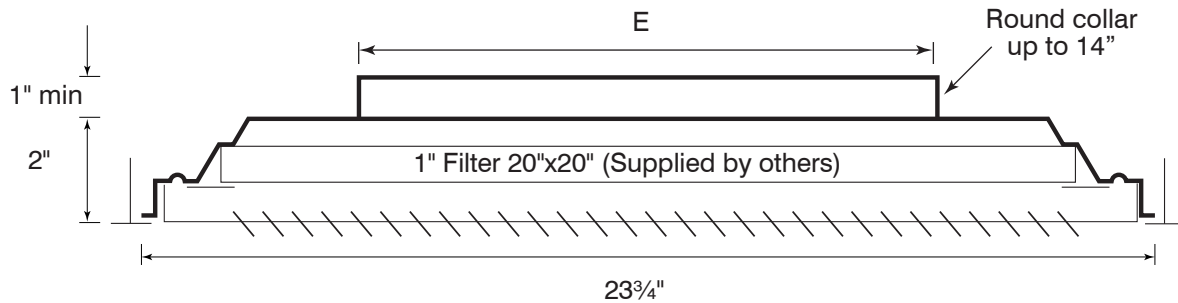
Contractor: _____

Lanced Face Filter Return with Steel Back Panel, Hinged Face

- Material:** Stamped heavy gauge steel backpanel with reinforcing corners. Steel lanced face with 1/2" spaced fins at 40o swings in and out of fixed frame, for access to 20"x20" filter, by others.
- Finish:** Powder paint coating - white.
- Safety:** Seismic tabs.
- Mounting:** T-bar Lay-in ceiling.



LRMF



✓	Model #	Duct Size	E	Face Dim
	LRMF 2406	6	5 7/8"	23 3/4" x 23 3/4"
	LRMF 2408	8	7 7/8"	23 3/4" x 23 3/4"
	LRMF 2410	10	9 7/8"	23 3/4" x 23 3/4"
	LRMF 2412	12	11 7/8"	23 3/4" x 23 3/4"
	LRMF 2414	14	13 7/8"	23 3/4" x 23 3/4"

Finish	
<input type="checkbox"/> /W White (Default)	<input type="checkbox"/> /C Custom (Please Specify)



Schedule type: _____

Job: _____

Architect: _____

Engineer: _____

Contractor: _____

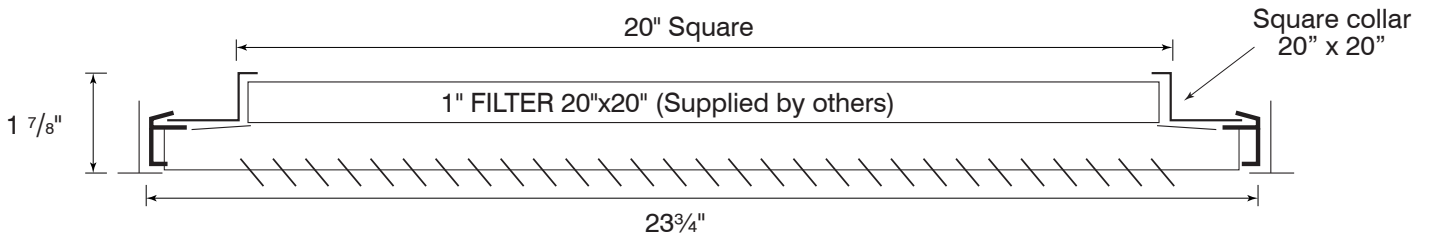
Lanced Face Filter Return with 20" x 20" filter frame Hinged face

- Material:** Steel filter frame will accept standard 1" filter. Steel lanced face with 1/2" spaced fins at 40° swings in and out of fixed frame, for access to 20"x20" filter, by others.
- Finish:** Powder paint coating - white.
- Mounting:** T-bar Lay-in ceiling.



LRTF

SUBMITTAL SHEET



Finish	
<input type="checkbox"/> /W White (Default)	<input type="checkbox"/> /C Custom (Please Specify)



Schedule type: _____

Job: _____

Architect: _____

Engineer: _____

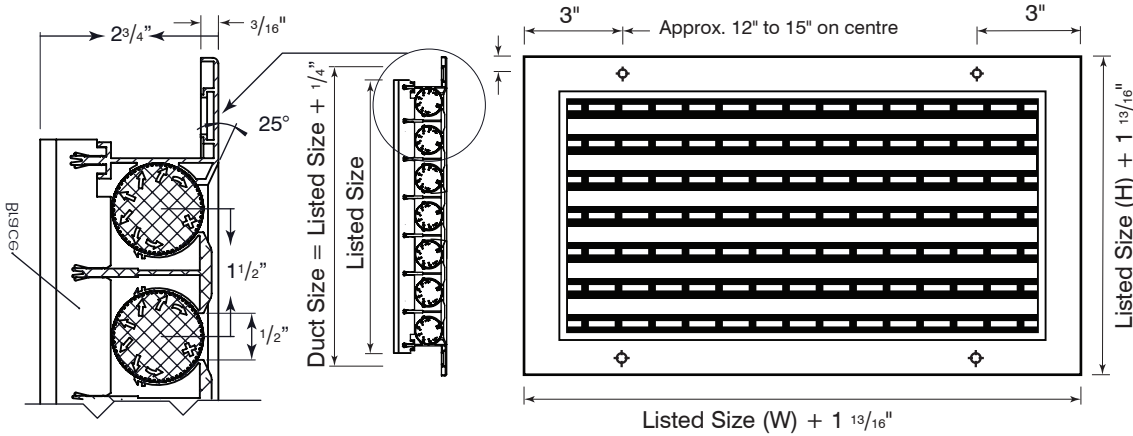
Contractor: _____

Induction Nozzle Grille

Material: Frame: Extruded aluminum construction,
Nozzle: Fire resistant polipropilen.



MSA



Options		
-GK Flange Gasket	-GN Neck Gasket	-GR Rear Gasket
-SF Supplied w/ sub frame	-DS Debris (Bird) Screen	-IS Insect Screen

Fastening Method		
-1 No Fastening 	-3 Screw Only with -T	-4 Concealed

Nozzle Color		
/W White (Default)	/BK Black	/C Custom (Please Specify) _____

Finish		
/W White (Default)	/BK Black	/C Custom (Please Specify) _____



Panel Option for T-bar lay-in Ceiling		Steel (WxH)	Aluminum (WxH)	
	<input type="checkbox"/>	-X1212	<input type="checkbox"/>	-Y1212
	<input type="checkbox"/>	-X1224	<input type="checkbox"/>	-Y1224
	<input type="checkbox"/>	-X2412	<input type="checkbox"/>	-Y2412
	<input type="checkbox"/>	-X2424	<input type="checkbox"/>	-Y2424
	<input type="checkbox"/>	-X2448	<input type="checkbox"/>	-Y2448
	<input type="checkbox"/>	-X4824	<input type="checkbox"/>	-Y4824
	<input type="checkbox"/>	-X2020	<input type="checkbox"/>	-Y2020

No fastening options available

Schedule type: _____

Job: _____

Architect: _____

Engineer: _____

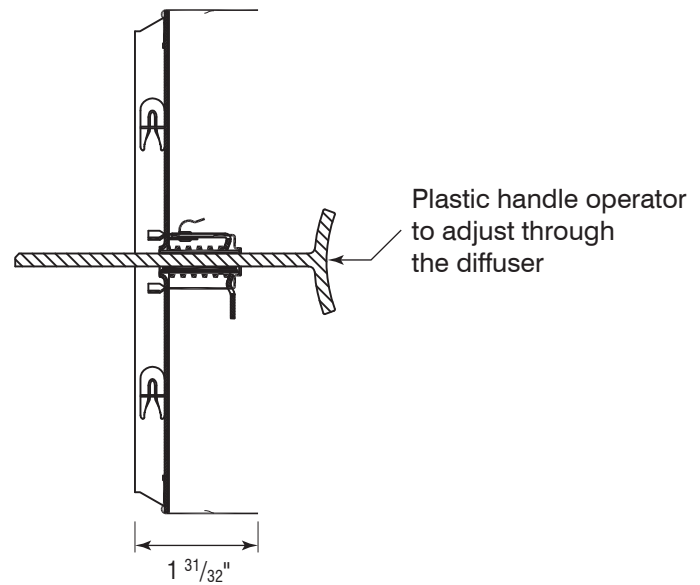
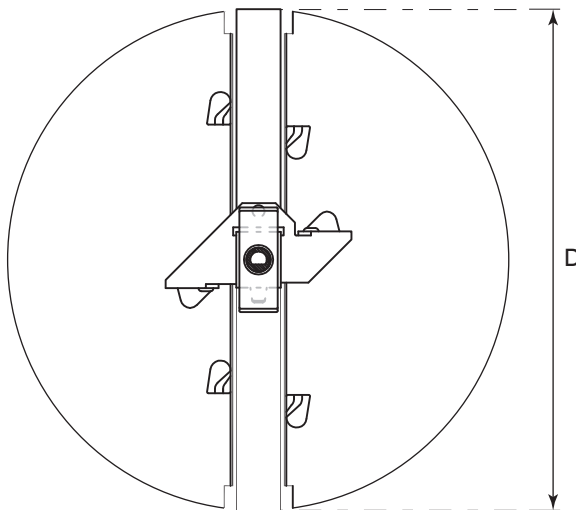
Contractor: _____

Round Butterfly Damper for DFX Series

Material: Heavy gauge steel.
Finish: Powder paint coating - light brown.
Adjustment: Plastic handle operator.



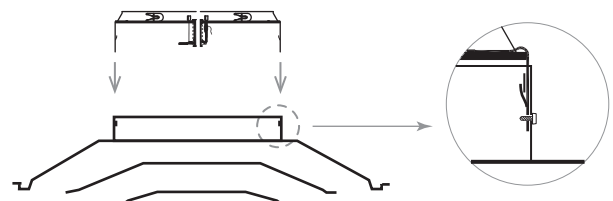
N2



SUBMITTAL SHEET

Installation

Clip damper into collar



✓	Model #	Nom. Size	Diameter (D)
	N4 06	6"	5 ¹¹ / ₁₆ "
	N4 08	8"	7 ¹¹ / ₁₆ "
	N4 10	10"	9 ¹¹ / ₁₆ "
	N4 12	12"	11 ¹¹ / ₁₆ "
	N4 14	14"	13 ¹¹ / ₁₆ "

Schedule type: _____

Job: _____

Architect: _____

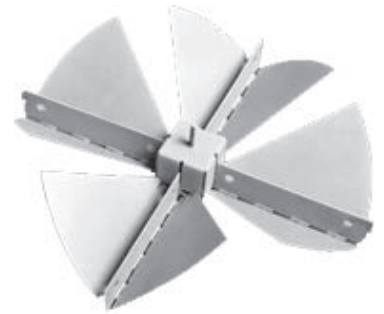
Engineer: _____

Contractor: _____

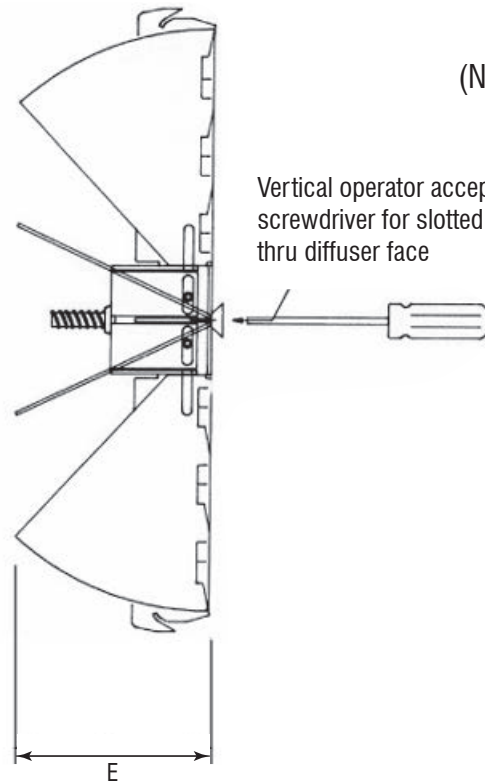
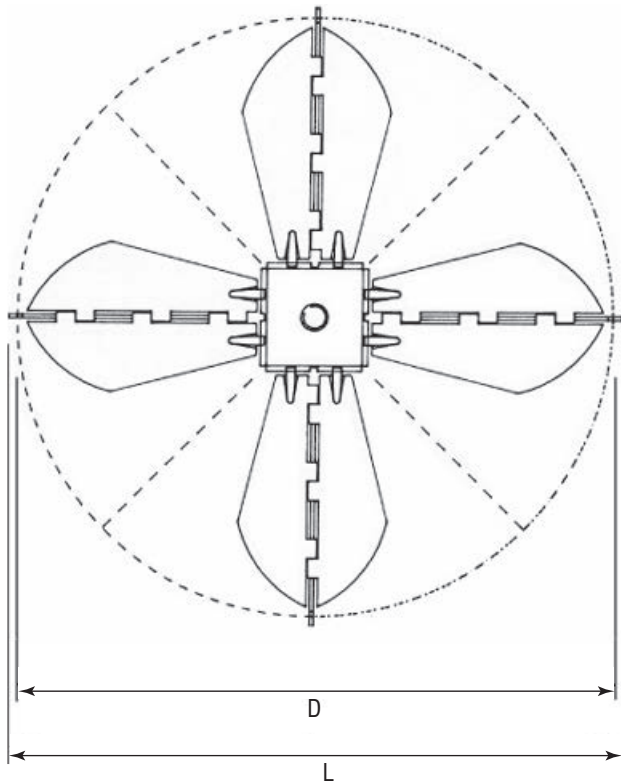
SUBMITTAL SHEET

Round Opposed Blade Damper

Material: All galvanized steel.
Mounting: Round collar of diffuser.

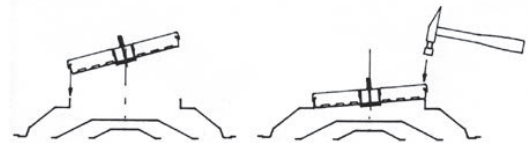


N4
(N4 08 shown here)



Vertical operator accepts standard screwdriver for slotted or hex head thru diffuser face

Installation



Finish

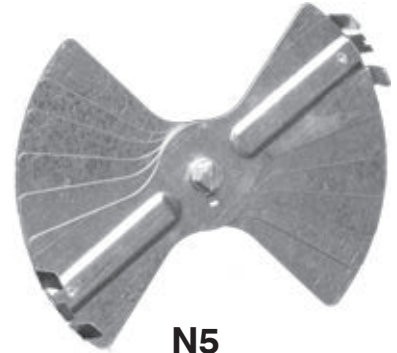
/M Mill Finish (Default) /BK Black

✓	Model #	Nom. Size	Overall Dimensions		
			Blade (D)	Brace (L)	Depth (E)
	N4 06	6"	5 3/4"	6"	2 3/8"
	N4 08	8"	7 3/4"	8"	3 1/8"
	N4 10	10"	9 3/4"	10"	3 3/4"
	N4 12	12"	11 3/4"	12"	4 1/2"
	N4 14	14"	13 3/4"	14"	5 1/4"

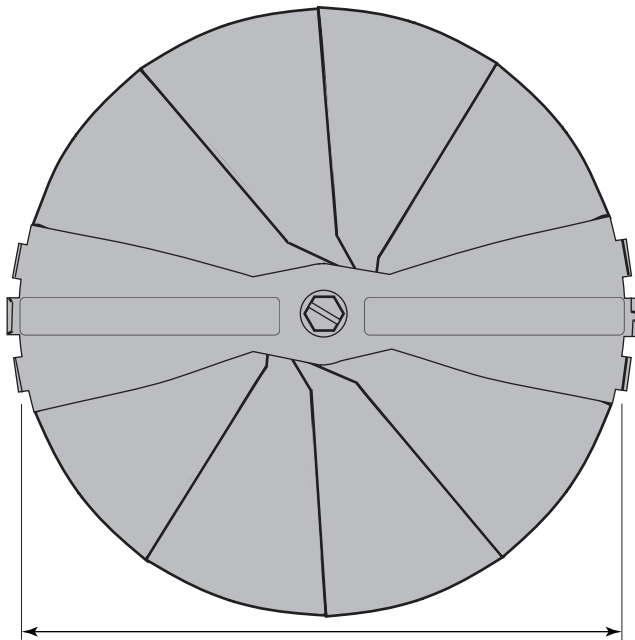
Schedule type: _____
 Job: _____
 Architect: _____
 Engineer: _____
 Contractor: _____

Round Sliding Blade Damper

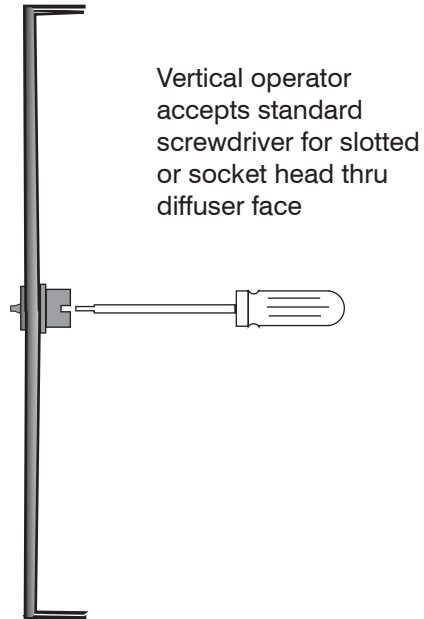
Material: All galvanized steel.
Mounting: Round collar of diffuser.


N5

SUBMITTAL SHEET



Actual Size = Nominal Size - 1/2"



Vertical operator accepts standard screwdriver for slotted or socket head thru diffuser face

✓	Model #	Nom. Size
	N5 06	6"
	N5 08	8"
	N5 10	10"
	N5 12	12"

Finish	
<input type="checkbox"/> /W White (Default)	<input type="checkbox"/> /C Custom (Please Specify)



Schedule type: _____

Job: _____

Architect: _____

Engineer: _____

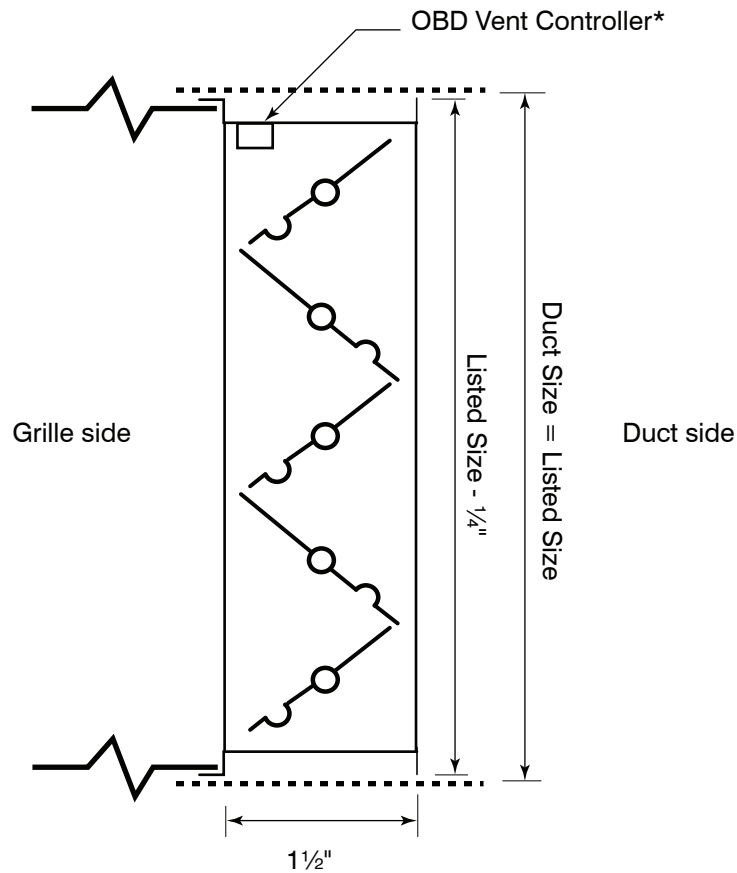
Contractor: _____

Square/Rectangular Opposed Blade Damper

Material: All galvanized steel
Mounting: Square/Rectangular fit to grille



N7



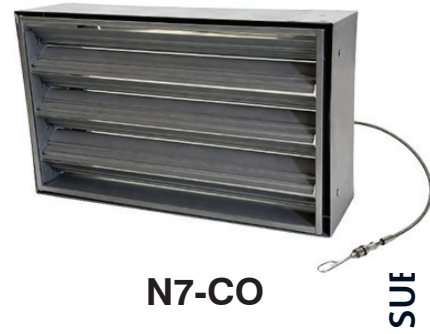
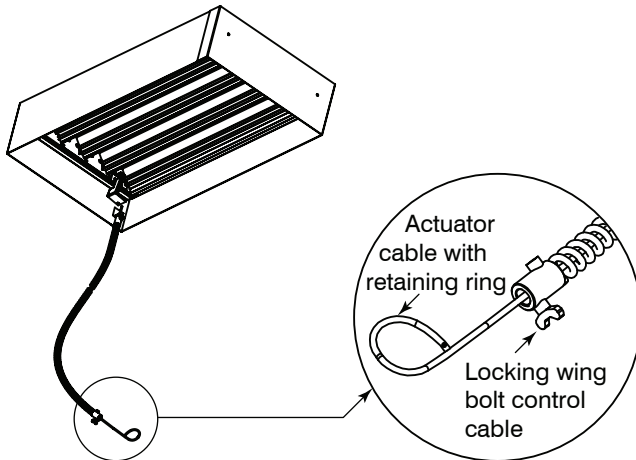
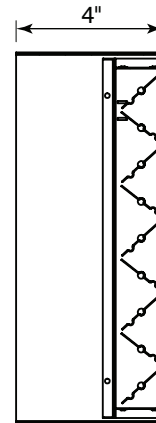
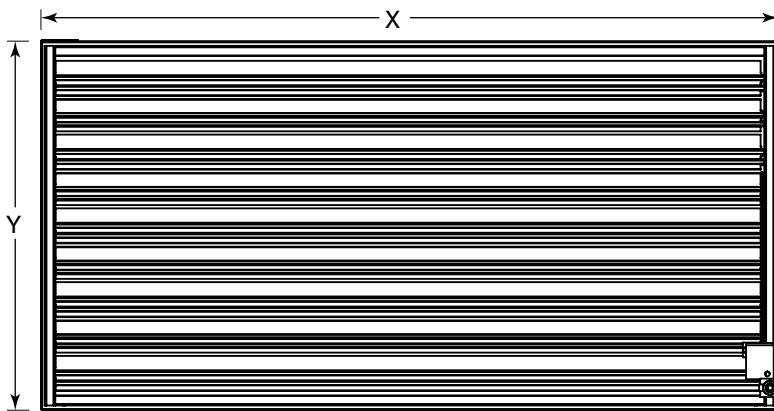
*OBD vent controller accepts standard screwdriver for slotted or socket head thru grille face

Sections are maximum 18 » x 18 ». Larger sizes are in multiple sections.

Schedule type: _____
Job: _____
Architect: _____
Engineer: _____
Contractor: _____

Opposed Blade Damper with Control Cable

- Material:** All galvanized steel frame and blades.
Drive cleat duct connection.
- Mounting:** Horizontally, vertical or any angle.
- Installation:** Operation not affected by position.


N7-CO
SUE


✓	Model #	X	Y
	NCO 1006	10"	06"
	NCO 1206	12"	06"
	NCO 1208	12"	08"
	NCO 1707	17"	07"
	NCO 1808	18"	08"
	NCO 2010	20"	10"
	NCO 2410	24"	10"

Schedule type: _____

Job: _____

Architect: _____

Engineer: _____

Contractor: _____

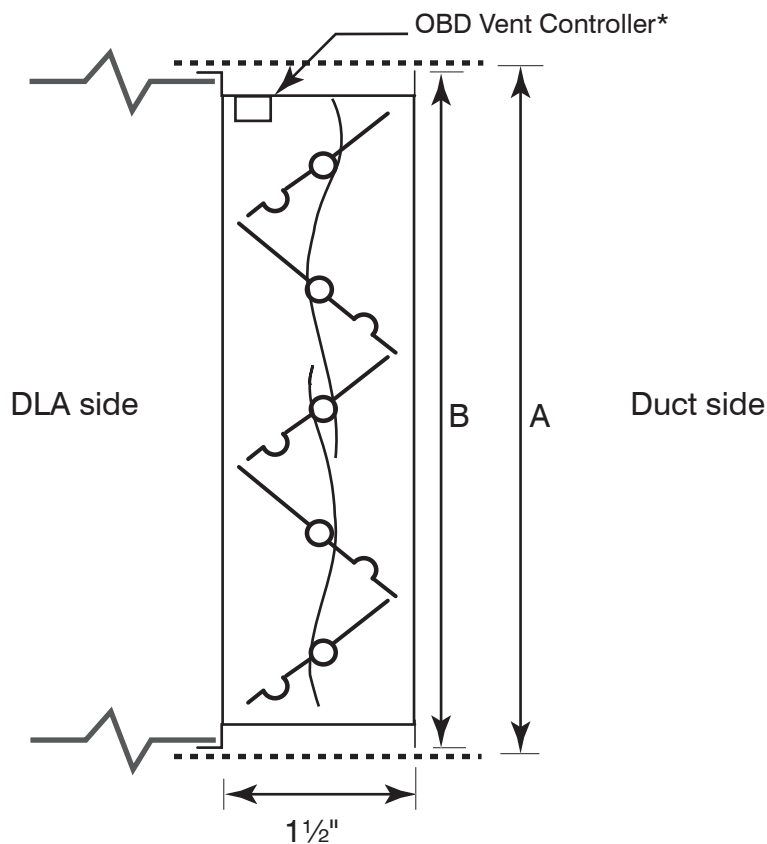
SUBMITTAL SHEET

Square Opposed Blade Damper for DLA Series

Material: Aluminum



N9



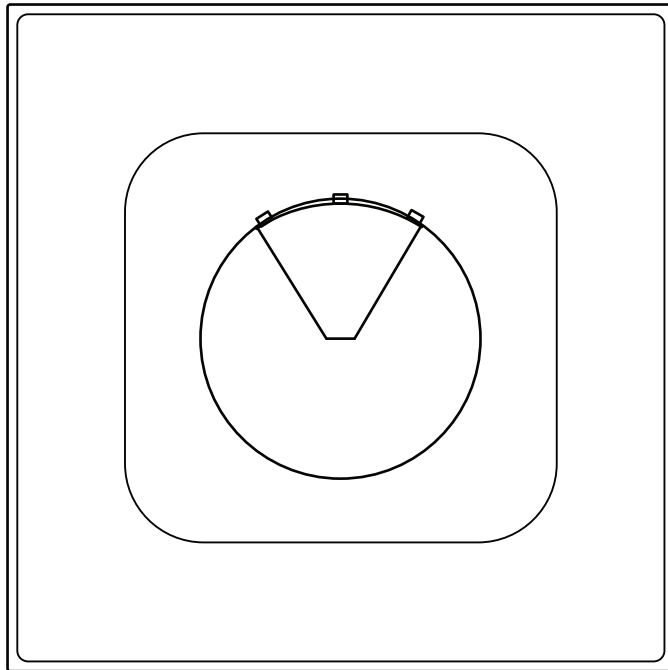
*OBD vent controller accepts standard screwdriver for slotted head

✓	Model #	Duct Dim A x A	Face Dim B x B
	N9 0606	6" x 6"	5 3/4" x 5 3/4"
	N9 0909	9" x 9"	8 3/4" x 8 3/4"
	N9 1212	12" x 12"	11 3/4" x 11 3/4"
	N9 1515	15" x 15"	14 3/4" x 14 3/4"
	N9 1818	18" x 18"	17 3/4" x 17 3/4"

Schedule type: _____
Job: _____
Architect: _____
Engineer: _____
Contractor: _____

Baffle For Cone Diffuser With Round Neck

Material: Galvanized steel.
Finish: Powder painting - Black.
Mounting: Clips.



(Top View)



✓	Model #	Duct Size	Neck Size
	NBD 06	6"	5 ⁷ / ₈ "
	NBD 08	8"	7 ⁷ / ₈ "
	NBD 10	10"	9 ⁷ / ₈ "
	NBD 12	12"	11 ⁷ / ₈ "
	NBD 14	14"	13 ⁷ / ₈ "

Schedule type: _____
 Job: _____
 Architect: _____
 Engineer: _____
 Contractor: _____

SUBMITTAL SHEET

N° NBI

Rev. 0

All dimensions are in inches

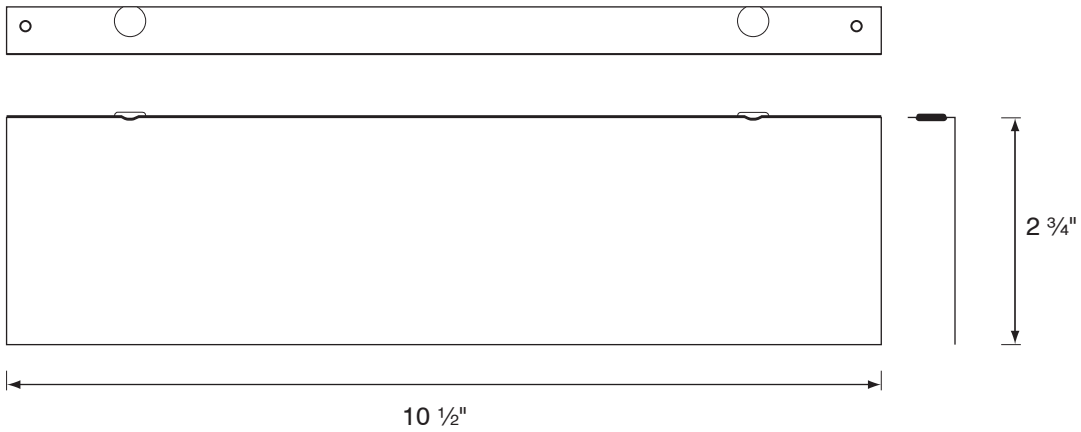
SUBMITTAL SHEET

Baffle for ISO plaque diffusers

Material: Galvanized Steel.
Finish: Powder painting - white.
Mounting: Magnets.



NBI



Finish	
<input type="checkbox"/> /W	<input type="checkbox"/> /C Custom (Please Specify)
White (Default)	_____



Schedule type: _____

Job: _____

Architect: _____

Engineer: _____

Contractor: _____

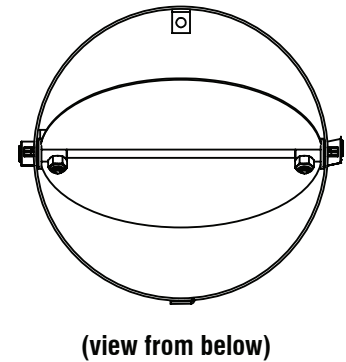
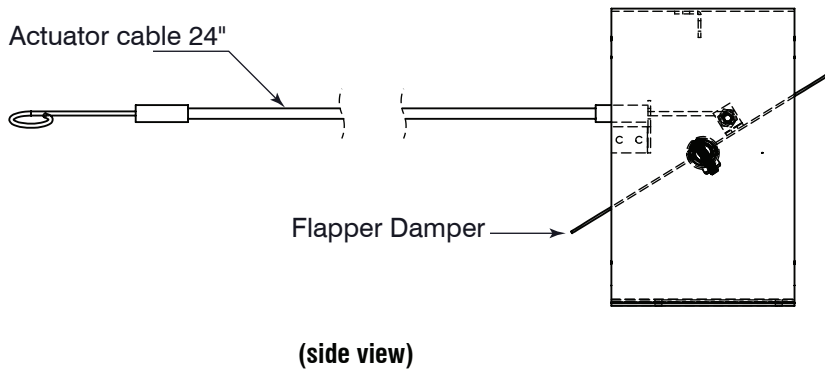
Round Baffle Damper

- Material:** 22 gauge galvanized steel frame.
16 gauge galvanized steel blade with gasket.
1/2" dia. steel drive shaft.
- Mounting:** Drive cleat duct connection.
- Installation:** Horizontally, vertical or any angle.
Operation not affected by position.



NCD

SUBMITTAL SHEET



✓	Model #	Duct Size	Neck Size
	NCD 04	4"	3 7/8"
	NCD 05	5"	4 7/8"
	NCD 06	6"	5 7/8"
	NCD 08	8"	7 7/8"
	NCD 10	10"	9 7/8"
	NCD 12	12"	11 7/8"
	NCD 14	14"	13 7/8"



Schedule type: _____

Job: _____

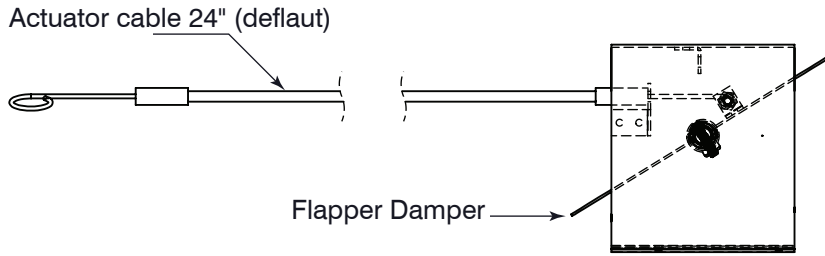
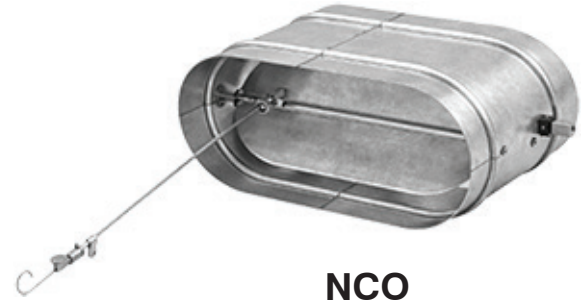
Architect: _____

Engineer: _____

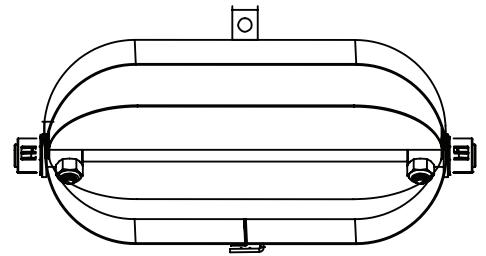
Contractor: _____

Oval Baffle Damper

- Material:** 22 gauge galvanized steel frame.
16 gauge galvanized steel blade with gasket.
1/2" dia. steel drive shaft.
- Mounting:** Drive cleat duct connection.
- Installation:** Horizontally, vertical or any angle.
Operation not affected by position.

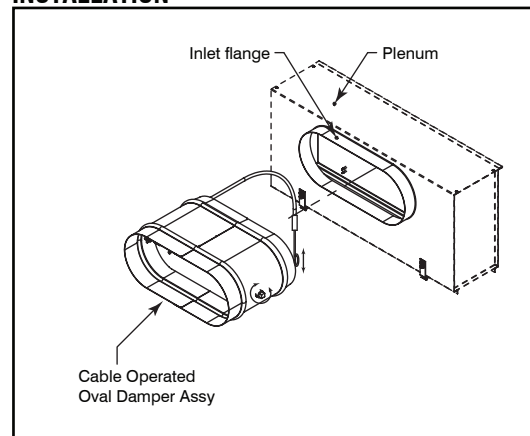


(Side View)



(Face View)

INSTALLATION



✓	Model #	Duct Size	Neck Size	
			A	B
	NCO 08	8"	9 3/8"	5 1/4"
	NCO 10	10"	12 1/2"	5 1/4"
	NCO 12	12"	14 1/8"	7 7/8"

Schedule type: _____

Job: _____

Architect: _____

Engineer: _____

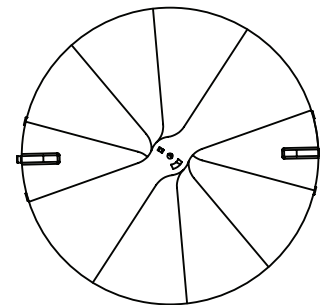
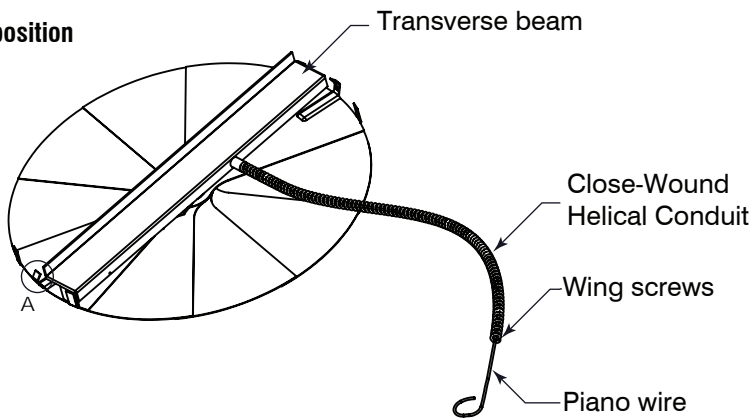
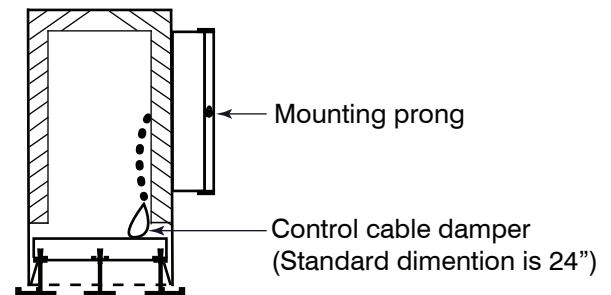
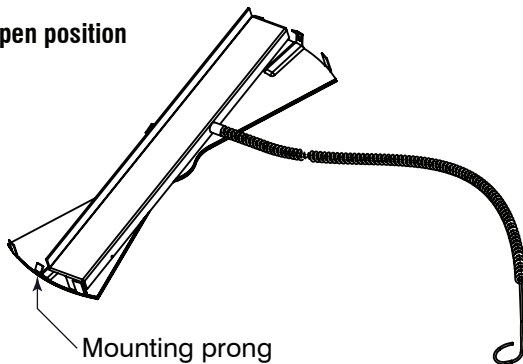
Contractor: _____

Round Radial Damper

- Material:** 22 gauge galvanized steel frame.
16 gauge galvanized steel blade with gasket.
1/2" dia. steel drive shaft.
- Mounting:** Drive cleat duct connection.
- Installation:** Horizontally, vertical or any angle.
Operation not affected by position.


NCR

SUBMITTAL SHEET

Closed position

(view from below)
Open position


✓	Model #	Duct Size	Neck Size
	NCR 06	6"	5 7/8"
	NCR 08	8"	7 7/8"
	NCR 10	10"	9 7/8"
	NCR 12	12"	11 7/8"
	NCR 14	14"	13 7/8"

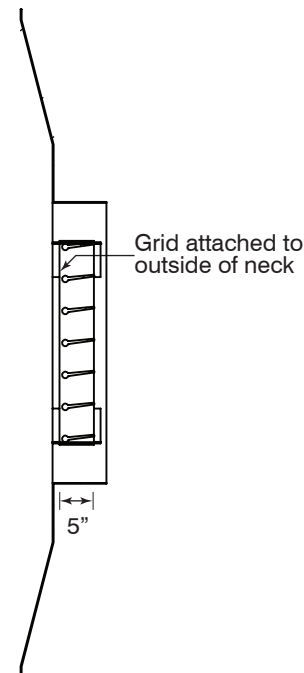
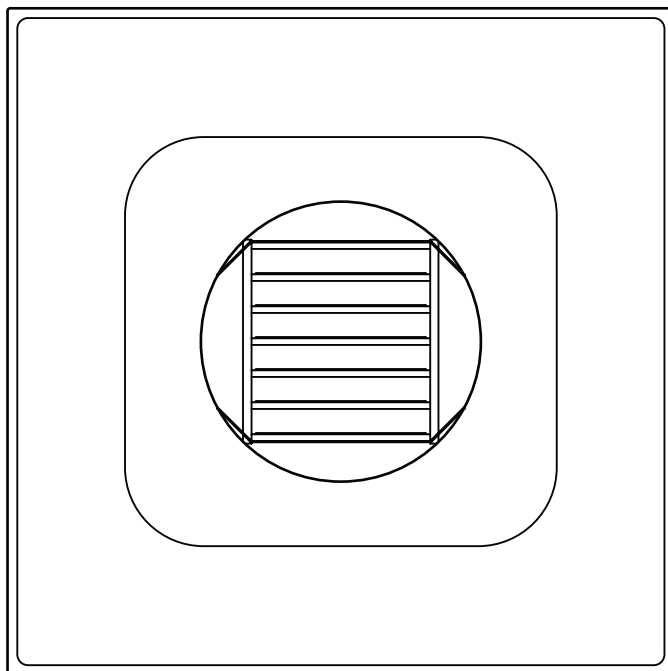
Schedule type: _____
Job: _____
Architect: _____
Engineer: _____
Contractor: _____

Round Equalizing Grid

Material: Extruded aluminum adjustable louver blades used to equalize air flow into round diffuser neck for minimum noise and turbulence.



NEG



✓	Model #	Duct Size	Neck Size
	NEG 06	6"	5 7/8"
	NEG 08	8"	7 7/8"
	NEG 10	10"	9 7/8"
	NEG 12	12"	11 7/8"
	NEG 14	14"	13 7/8"



Finish			
<input type="checkbox"/> /W White (Default)	<input type="checkbox"/> /B Black	<input type="checkbox"/> /M Mill Finish	<input type="checkbox"/> /C Custom (Please Specify)

Schedule type: _____

Job: _____

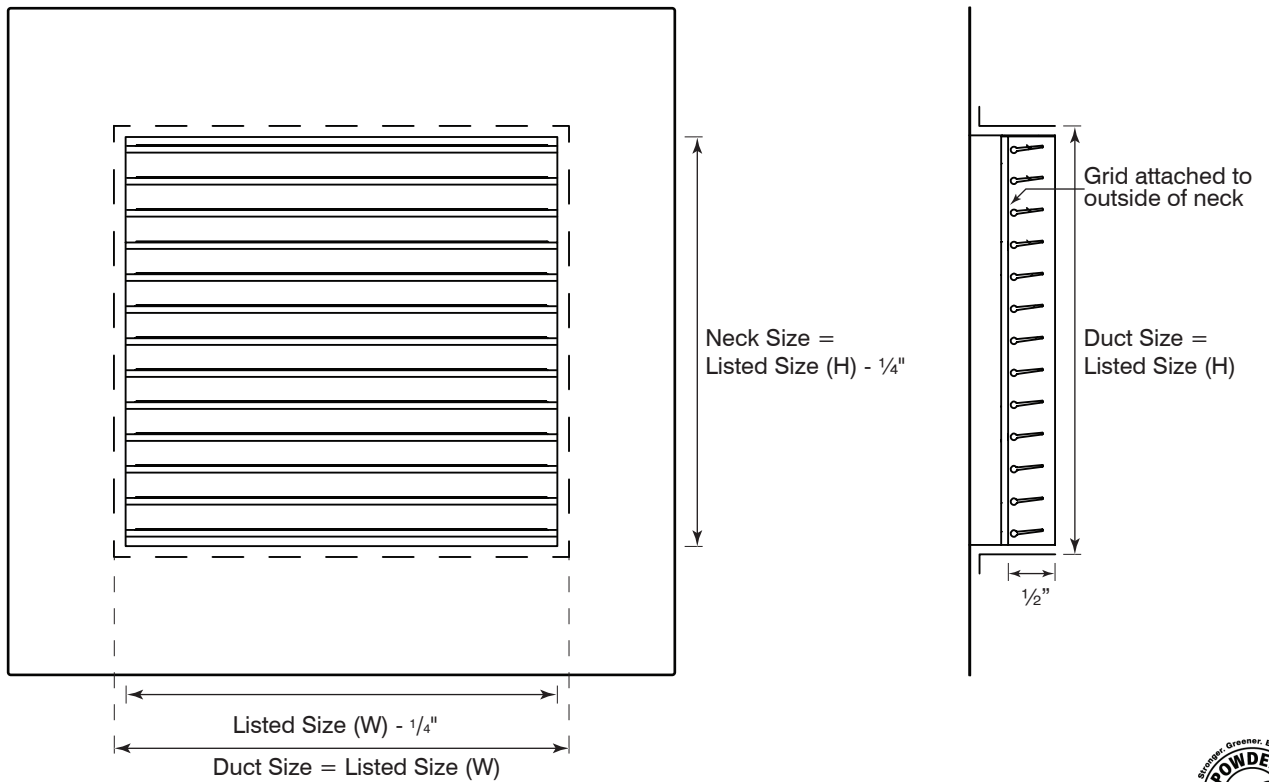
Architect: _____

Engineer: _____

Contractor: _____

Square Equalizing Grid

Material: Extruded aluminum adjustable louver blades used to equalize air flow into square diffuser neck for minimum noise and turbulence.



Maximum one piece dimension : 18" x 18"



✓	Model #
	NES 0606
	NES 0808
	NES 1010
	NES 1212
	NES 1414

Finish			
<input type="checkbox"/> /W White (Default)	<input type="checkbox"/> /B Black	<input type="checkbox"/> /M Mill Finish	<input type="checkbox"/> /C Custom (Please Specify)

Schedule type: _____

Job: _____

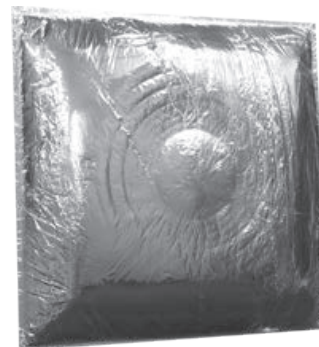
Architect: _____

Engineer: _____

Contractor: _____

R6 Molded Fiberglass Backpan

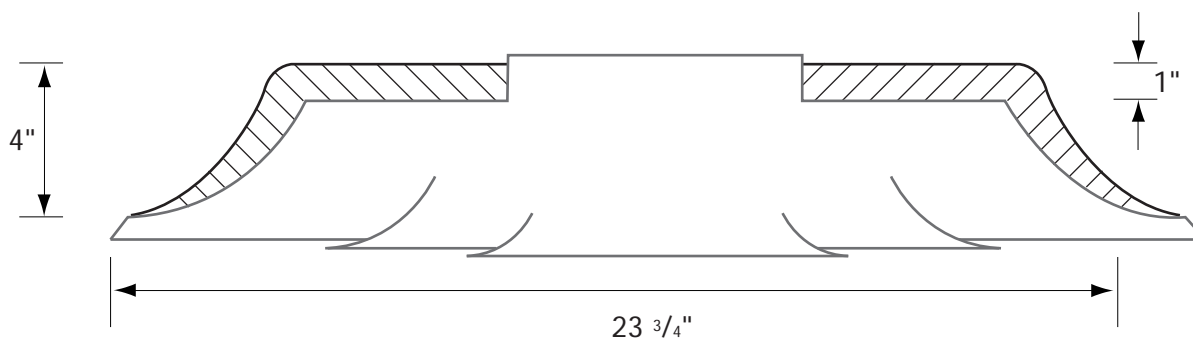
Material: Molded fiberglass with a foil layer on the exterior.



NR6MFG

R6 fiberglass back complies with A.S.T.M. E84 flame and smoke test.

Scored for collar sizes up to 12" D. Contractor to install job-specific collar in field. For size 14", please refer to model DF3-R6 2414. (Available only on models with 24" x 24" face diffusers).



Schedule type: _____
Job: _____
Architect: _____
Engineer: _____
Contractor: _____

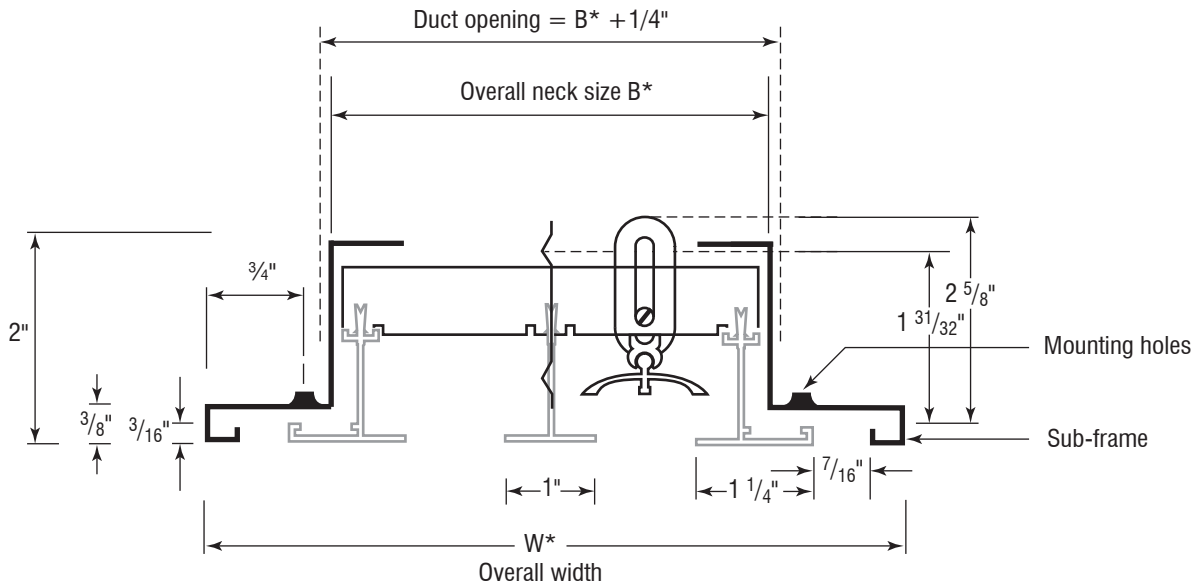
Sub-Frame for Linear 1" Slot Diffuser

Material: Extruded aluminum construction
Mounting: Countersunk mounting holes on sub-frame.



NSA1

SUBMITTAL SHEET



✓	NO. OF SLOTS	B*	W*
	01	2 5/8"	5"
	02	4 5/8"	7"
	03	6 5/8"	9"
	04	8 5/8"	11"
	05	10 5/8"	13"
	06	12 5/8"	15"
	07	14 5/8"	17"
	08	16 5/8"	19"

Finish	
<input type="checkbox"/> /W White (Default)	<input type="checkbox"/> /C Custom (Please Specify)



Mounting	
Surface mounting -E <input type="checkbox"/>	
	Overall Length = List Length + 2 3/8" Duct Opening = List Length + 1/4" Neck Size = List Length

Schedule type: _____

Job: _____

Architect: _____

Engineer: _____

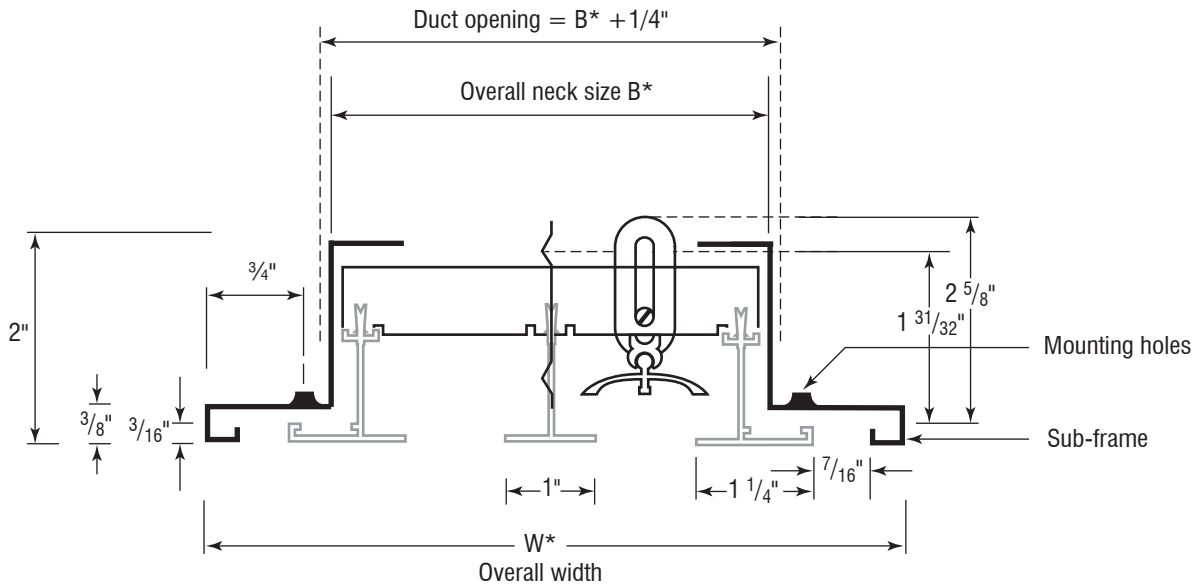
Contractor: _____

Sub-Frame for Linear 3/4" Slot Diffuser

Material: Extruded aluminum construction
Mounting: Countersunk mounting holes on sub-frame.



NSA3



✓	NO. OF SLOTS	B*	W*
	01	2 1/16"	4 7/16"
	02	3 1/2"	5 7/8"
	03	4 15/16"	7 5/16"
	04	6 3/8"	8 3/4"
	05	7 13/16"	10 3/16"
	06	9 1/4"	11 5/8"
	07	10 11/16"	13 1/16"
	08	12 1/8"	14 1/2"

Finish	
<input type="checkbox"/> /W White (Default)	<input type="checkbox"/> /C Custom (Please Specify)



Mounting	
Surface mounting -E	
	<p>Overall Length = List Length + 2 3/8"</p> <p>Duct Opening = List Length + 1/4"</p> <p>Neck Size = List Length</p>

Schedule type: _____

Job: _____

Architect: _____

Engineer: _____

Contractor: _____

Frame for Narrow T-Bar

Material: Aluminium construction.

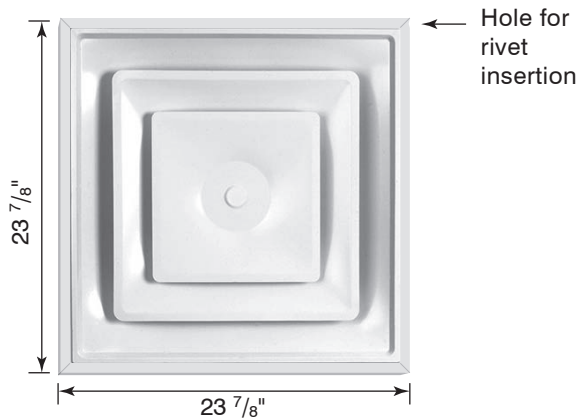


NT
(DF3-NT shown here)

Bending Operation



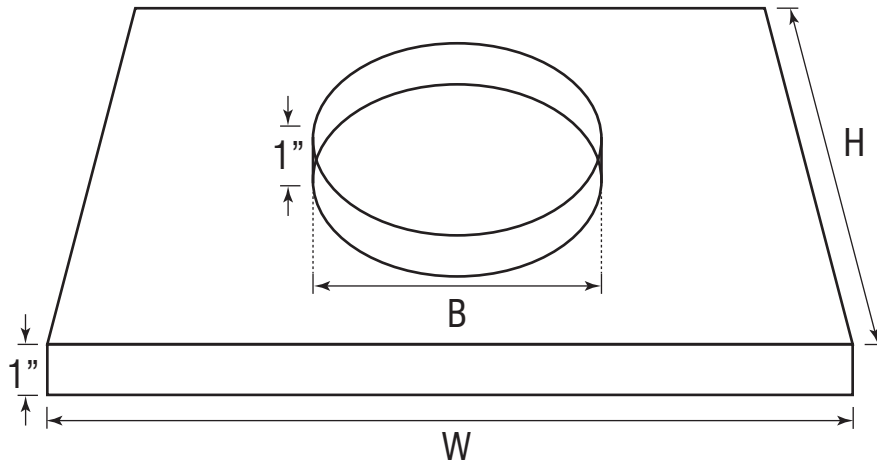
Riveting Operation



Schedule type: _____
Job: _____
Architect: _____
Engineer: _____
Contractor: _____

Square to Round Transition

Material: 22 gauge steel.



✓	Listed W	Listed H	Actual Interior Dimension
	24	12	24" x 12"
	22	12	22" x 12"
	12	10	12" x 10"
	10	08	10" x 8"

✓	Listed B	Actual Exterior Dimension
	06	5 7/8"
	08	7 7/8"
	10	9 7/8"
	12	11 7/8"
	14	13 7/8"



Finish		
<input type="checkbox"/> /W White (Default)	<input type="checkbox"/> /M Mill Finish	<input type="checkbox"/> /C Custom (Please Specify)

Schedule type: _____

Job: _____

Architect: _____

Engineer: _____

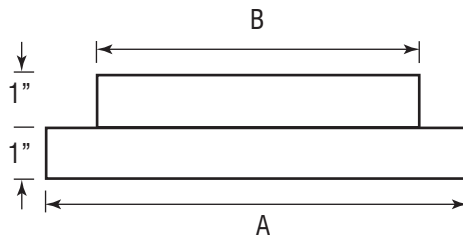
Contractor: _____

Round to Round Transition

Material: 22 gauge galvanized steel.

Standard is Imperial - Imperial

-MI : Metric - Imperial



✓	Model #	A interior dim Diffuser Collar Insert	B exterior dim Duct Connection
	NTRR 0604	6" D	3 3/4" D
	NTRR 0605	6" D	4 3/4" D
	NTRR 0807	8" D	6 3/4" D
	NTRR 1009	10" D	8 3/4" D
	NTRR 1415	14" D	14 3/4" D
	NTRR 1416	14" D	15 3/4" D
	NTRR-MI 160 6	165 mm D	5 3/4" D
	NTRR-MI 315 12	320 mm D	11 3/4" D

Finish		
<input type="checkbox"/> /M Mill Finish	<input type="checkbox"/> /W White (default)	<input type="checkbox"/> Custom (please specify)

Schedule type: _____

Job: _____

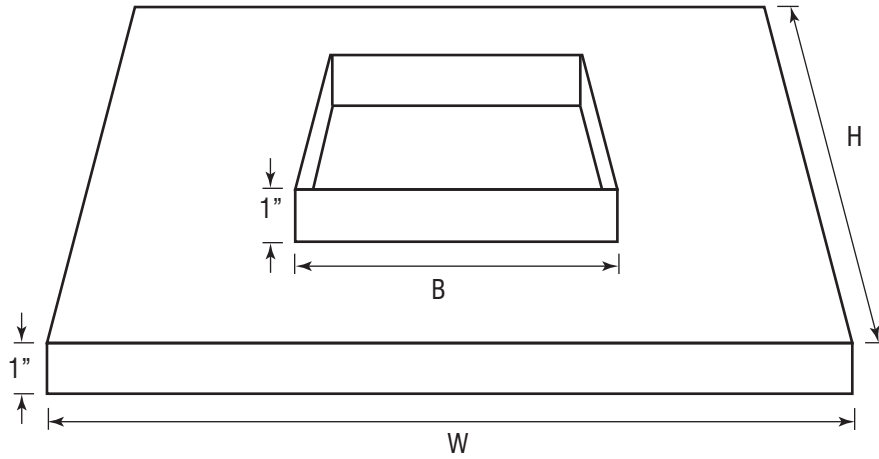
Architect: _____

Engineer: _____

Contractor: _____

Square to Quad Transition

Material: 22 gauge steel.



✓	Listed A	Actual Interior Dimension
	2424	24" x 24"
	2222	22" x 22"
	1212	12" x 12"
	1010	10" x 10"

✓	Listed W	Listed H	Actual Exterior Dimension
	22	20	21 7/8" x 19 7/8"
	20	18	19 7/8" x 17 7/8"
	18	16	17 7/8" x 15 7/8"
	16	14	15 7/8" x 13 7/8"
	14	12	13 7/8" x 11 7/8"
	12	10	11 7/8" x 9 7/8"
	10	08	9 7/8" x 7 7/8"
	08	06	7 7/8" x 5 7/8"
	06	04	5 7/8" x 3 7/8"



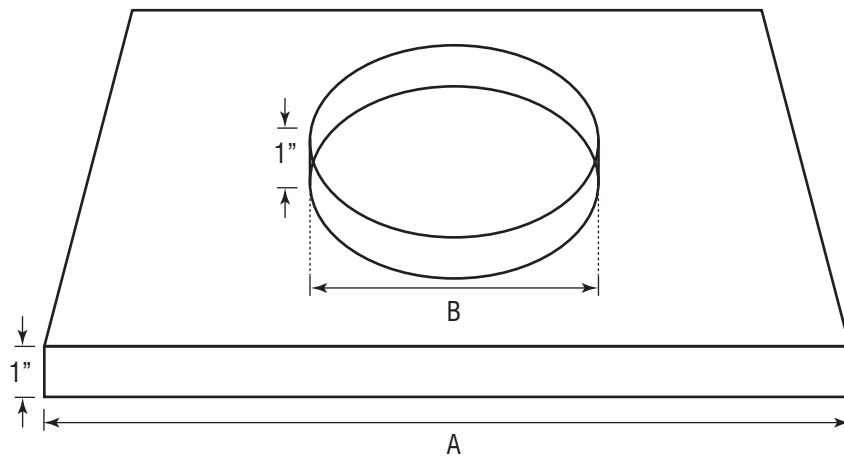
Finish		
<input type="checkbox"/> /W White (Default)	<input type="checkbox"/> /M Mill Finish	<input type="checkbox"/> /C Custom (Please Specify)

Schedule type: _____
Job: _____
Architect: _____
Engineer: _____
Contractor: _____

Square to Round Transition

Material: 22 gauge steel.

SUBMITTAL SHEET



✓	Listed	Actual Interior Dimension
	24	24" x 24"
	22	22" x 22"
	12	12" x 12"
	10	10" x 10"

✓	Listed B	Actual Exterior Dimension
	06	5 7/8"
	08	7 7/8"
	10	9 7/8"
	12	11 7/8"
	14	13 7/8"

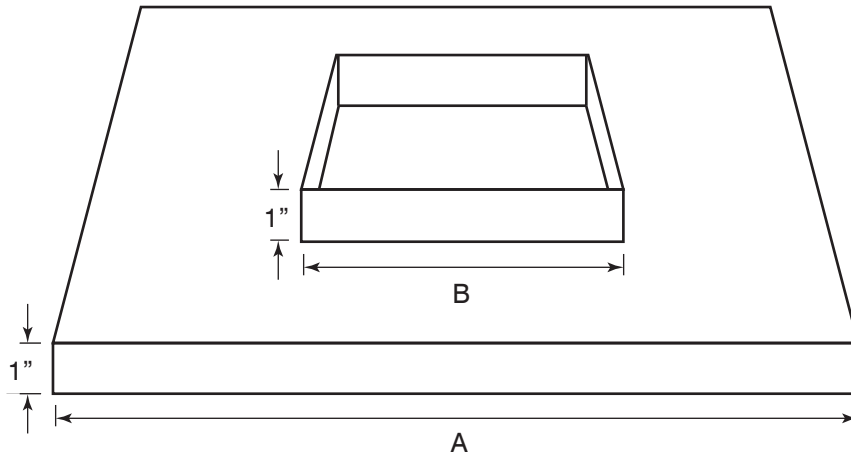


Finish		
<input type="checkbox"/> /W White <small>(Default)</small>	<input type="checkbox"/> /M Mill Finish	<input type="checkbox"/> /C Custom <small>(Please Specify)</small>

Schedule type: _____
Job: _____
Architect: _____
Engineer: _____
Contractor: _____

Square to Square Transition

Material: 22 gauge steel.



✓	Listed A	Actual Interior Dimension
	2424	24" x 24"
	2222	22" x 22"
	1212	12" x 12"
	1010	10" x 10"

✓	Listed B	Actual Interior Dimension
	2222	21 7/8" x 21 7/8"
	2020	19 7/8" x 19 7/8"
	1818	17 7/8" x 17 7/8"
	1616	15 7/8" x 15 7/8"
	1414	13 7/8" x 13 7/8"
	1212	11 7/8" x 11 7/8"
	1010	9 7/8" x 9 7/8"
	0808	7 7/8" x 7 7/8"
	0606	5 7/8" x 5 7/8"
	0404	3 7/8" x 3 7/8"

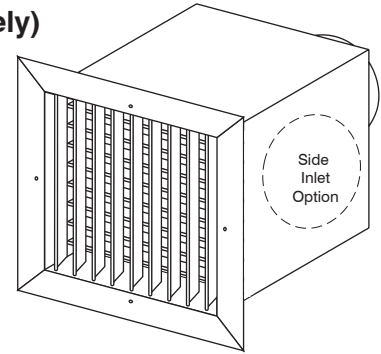


Finish		
<input type="checkbox"/> /W White <small>(Default)</small>	<input type="checkbox"/> /M Mill Finish	<input type="checkbox"/> /C Custom <small>(Please Specify)</small>

Schedule type: _____
Job: _____
Architect: _____
Engineer: _____
Contractor: _____

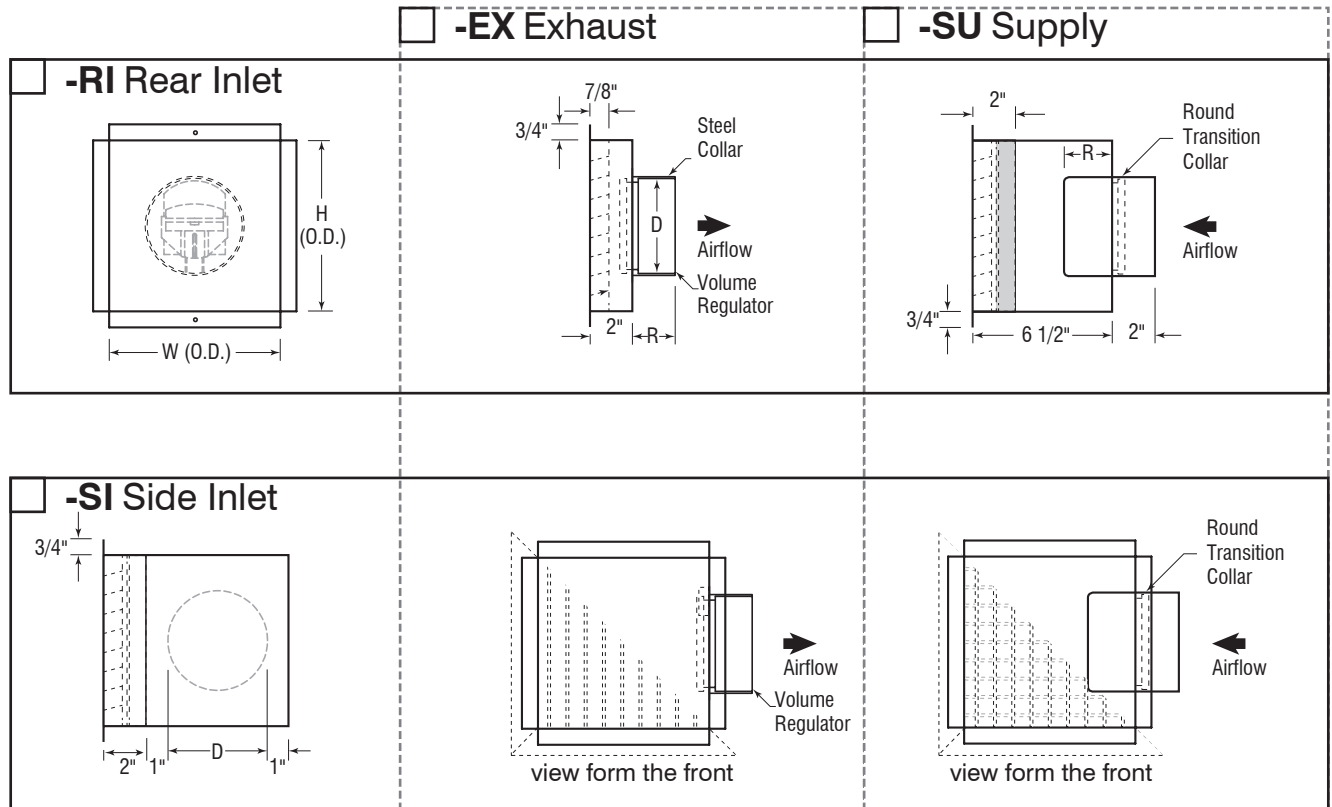
Constant Volume Regulator Plenum (grille sold separately)

Material: Car boot: 24 ga. galvanized steel.
Volume Damper: UL94V-0 ABS plastic.
Finish: Satin Coat Steel.
Mounting: Ceiling.


NVRPL

(Please order grille separately)

SUBMITTAL SHEET



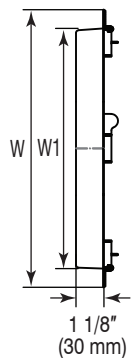
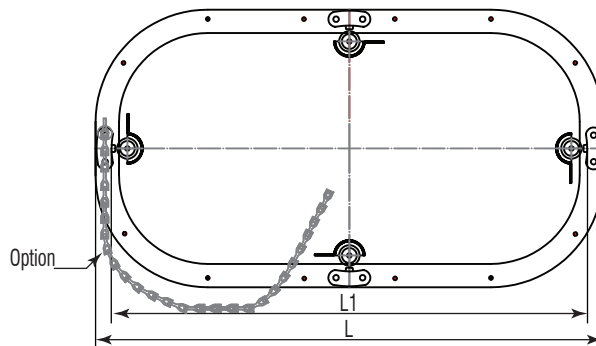
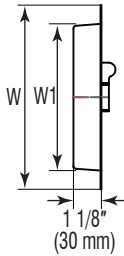
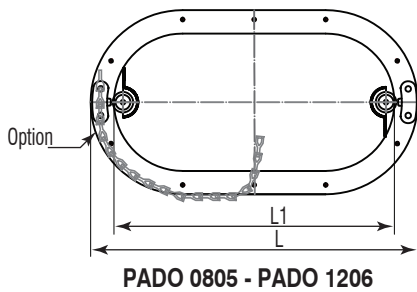
SP Standard Pressure Range of Operation (Static Pressure)	
Mini.	0.2" w.g.
Max.	1.0" w.g.

Plenum Size	Regulator (Nominal)	W Height	H Height	D Dia.	R
6"x6" (152 x 152)	4" (102)	6" (152)	6" (152)	3 ¹¹ / ₁₆ " (94)	2 ¹ / ₄ " (57)
6"x6" (152 x 152)	5" (127)	6" (152)	6" (152)	4 ⁵ / ₈ " (117)	3 ³ / ₁₆ " (80)
8"x8" (203 x 203)	4" (102)	8" (203)	8" (203)	3 ¹¹ / ₁₆ " (94)	2 ¹ / ₄ " (57)
8"x8" (203 x 203)	5" (127)	8" (203)	8" (203)	4 ⁵ / ₈ " (117)	3 ³ / ₁₆ " (80)
8"x8" (203 x 203)	6" (152)	8" (203)	8" (203)	5 ⁷ / ₈ " (150)	3 ³ / ₁₆ " (80)
10"x10" (254 x 254)	6" (152)	10" (254)	10" (254)	5 ⁷ / ₈ " (150)	3 ³ / ₁₆ " (80)
10"x10" (254 x 254)	8" (203)	10" (254)	10" (254)	7 ¹¹ / ₁₆ " (196)	3 ⁵ / ₁₆ " (85)
12"x12" (305 x 305)	8" (203)	12" (305)	12" (305)	7 ¹¹ / ₁₆ " (196)	3 ⁵ / ₁₆ " (85)
12"x12" (305 x 305)	10" (254)	12" (305)	12" (305)	9 ⁵ / ₈ " (244)	4 ¹ / ₄ " (108)

Schedule type: _____
 Job: _____
 Architect: _____
 Engineer: _____
 Contractor: _____

Low Leakage Flat Oval Access Door

- Material:** 22ga (0.85) galvanized door panel and flanged frame (Die-formed).
- Hinge:** Plated steel camlock fasteners
- Insulation:** 1" (25) Styrofoam with a 22ga galvanized backing plate.
- Mounting:** 3/16" (5) dia. pre-punched holes on inner flange for surface mounting.
- Application:** Adaptable to all Ducts 5" (127) or Over.
- Template:** Layout template included on each box.



✓	Model	Nominal Size	L1	W1	L	W	Qty. /Box
	PADO 0805	8" x 5" (200 mm x 125mm)	5 1/8" (205 mm)	5" (129 mm)	9 1/2" (241 mm)	6 1/2" (165 mm)	20
	PADO 1206	12" x 6" (300mm x 150 mm)	12" 1/8" (309 mm)	6 1/2" (158 mm)	13 3/4" (349 mm)	7 3/4" (198 mm)	10
	PADO 1810	18" x 10" (460 mm x 250 mm)	18 1/2" (462 mm)	10 1/4" (260 mm)	19 3/4" (502 mm)	11 7/8" (300 mm)	10
	PADO 2114	21" x 14" (530 mm x 360 mm)	21 1/4" (540 mm)	14 1/8" (360 mm)	13 7/8" (580 mm)	15 3/4" (400 mm)	5
	PADO 2517	25" x 17" (635 mm x 430 mm)	25 1/8" (640 mm)	17 1/4" (438 mm)	26 3/4" (680 mm)	19 7/8" (478 mm)	4

Option

-SC Safety Chain

Model Description

Low leakage, quality and performance access door. Flat oval design, double flanged door with pre-punched holes on inner flange for surface mounting optimizes access area and simplifies installation.

Schedule type: _____

Job: _____

Architect: _____

Engineer: _____

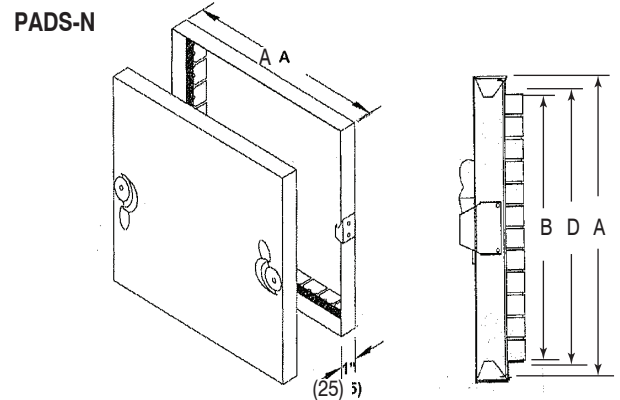
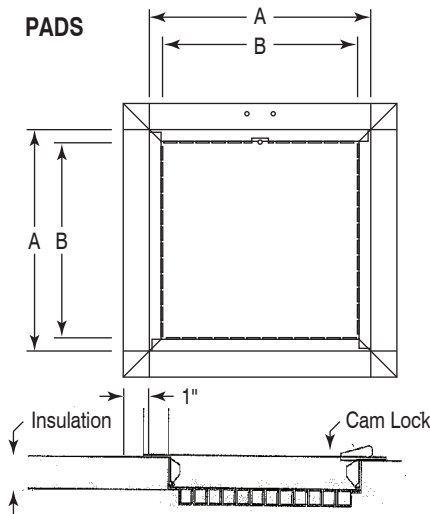
Contractor: _____

Low Leakage Square Access Door

- Material:** 22 ga Steel Construction,
Neoprene gasket behind frame and door for low leakage.
- Hinge:** Camlock Operation. 2 camlocks for 16" under, 4 over 16".
- Insulation:** 1" (25) Styrofoam.
- Mounting:** Notched knock-over.
- Application:** Adaptable to all Ducts 5" (127) or Over.



SUBMITTAL SHEET



✓	Model	Nominal Size	A	B	D (Duct Dimensions)	Qty. /Box
<input type="checkbox"/>	PADS 0606	6" x 6" (152 mm x 152 mm)	6" (152 mm)	4 7/8" (124 mm)	5" (127 mm)	20
<input type="checkbox"/>	PADS 0808	8" x 8" (203 mm x 203 mm)	8" (203 mm)	6 7/8" (175 mm)	7" (178 mm)	20
<input type="checkbox"/>	PADS 1010	10" x 10" (254 mm x 254 mm)	10" (254 mm)	8 7/8" (226 mm)	9" (229 mm)	20
<input type="checkbox"/>	PADS 1212	12" x 12" (305 mm x 305 mm)	12" (305 mm)	10 7/8" (277 mm)	11" (280 mm)	10
<input type="checkbox"/>	PADS 1414	14" x 14" (356 mm x 356 mm)	14" (356 mm)	12 7/8" (328 mm)	13" (331 mm)	10
<input type="checkbox"/>	PADS 1616	16" x 16" (406 mm x 406 mm)	16" (406 mm)	14 7/8" (378 mm)	15" (381 mm)	10
<input type="checkbox"/>	PADS 1818	18" x 18" (457 mm x 457 mm)	18" (457 mm)	16 7/8" (429 mm)	17" (432 mm)	8
<input type="checkbox"/>	PADS 2020	20" x 20" (508 mm x 508 mm)	20" (508 mm)	18 7/8" (480 mm)	19" (483 mm)	6
<input type="checkbox"/>	PADS 2222	22" x 22" (559 mm x 559 mm)	22" (559 mm)	20 7/8" (531 mm)	21" (534 mm)	5
<input type="checkbox"/>	PADS 2424	24" x 24" (610 mm x 610 mm)	24" (610 mm)	22 7/8" (582 mm)	23" (585 mm)	4

Option
<input type="checkbox"/> -N No Flange

Schedule type: _____

Job: _____

Architect: _____

Engineer: _____

Contractor: _____

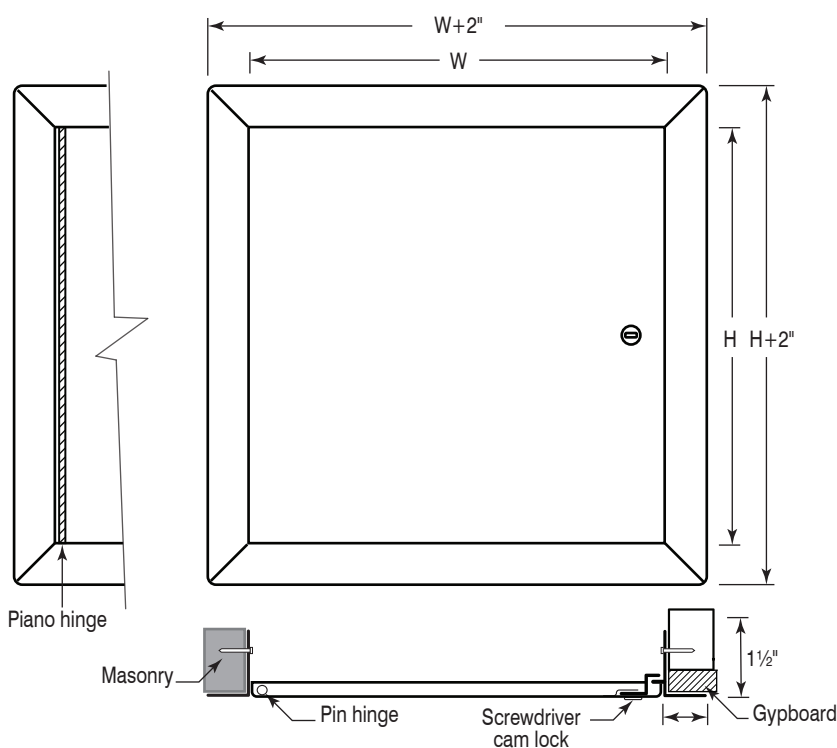
SUBMITTAL SHEET

General Purpose Access Door For All Surface Types

- Material:** 16 ga steel construction.
Hinge: Hidden pin hinge or continuous piano type on doors over 24" (height or width).
Lock / Latch: Screwdriver operated cam latch.
Finish: Powder paint coating - white.



PAHD



Gasket	
<input type="checkbox"/>	-GK

Lock and latch options									
<input type="checkbox"/>	-K# Key operated cylinder cam latch	<input type="checkbox"/>	-H# Hex head cam latch	<input type="checkbox"/>	-HP# pinned hex head cam latch	<input type="checkbox"/>	-HL# Handle operated cam latch	<input type="checkbox"/>	-MCP Mortise cylinder preparation

Finish	
<input type="checkbox"/>	/W White (Default)
<input type="checkbox"/>	/C Custom (Please Specify)



Door size W x H (#Number of locks/latches)		
<input type="checkbox"/>	6 x 6 (1)	12 x 24 (1)
<input type="checkbox"/>	8 x 8 (1)	14 x 14 (1)
<input type="checkbox"/>	8 x 12 (1)	16 x 16 (1)
<input type="checkbox"/>	10 x 10 (1)	18 x 18 (1)
<input type="checkbox"/>	12 x 12 (1)	18 x 24 (1)
<input type="checkbox"/>	12 x 16 (1)	20 x 20 (1)
<input type="checkbox"/>	12 x 18 (1)	22 x 22 (1)
<input type="checkbox"/>		*22 x 30 (2)
<input type="checkbox"/>		*22 x 36 (2)
<input type="checkbox"/>		*24 x 24 (1)
<input type="checkbox"/>		*24 x 30 (2)
<input type="checkbox"/>		*24 x 36 (2)
<input type="checkbox"/>		*24 x 48 (2)
<input type="checkbox"/>		*30 x 30 (4)
<input type="checkbox"/>		*36 x 36 (4)

*Piano hinge on doors over 24 inches (W or H).

Schedule type: _____

Job: _____

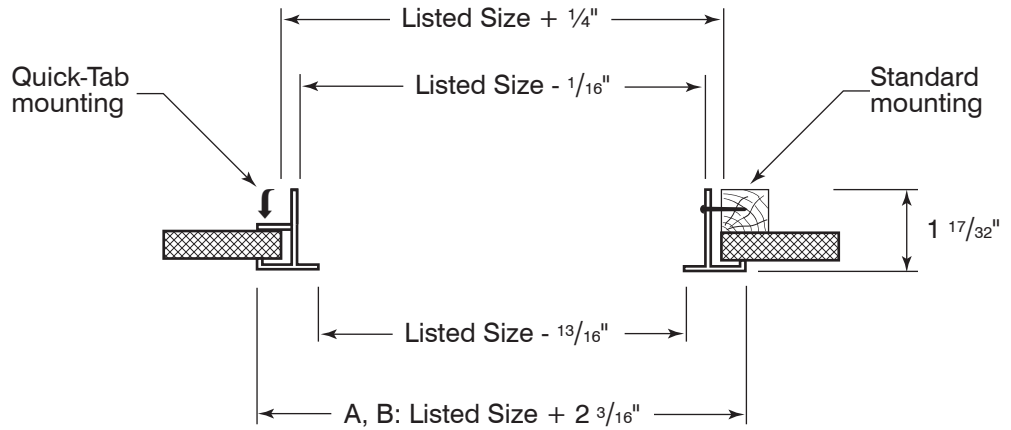
Architect: _____

Engineer: _____

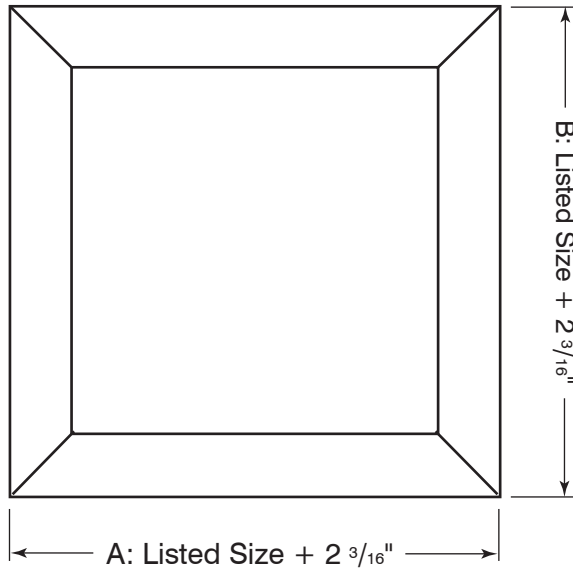
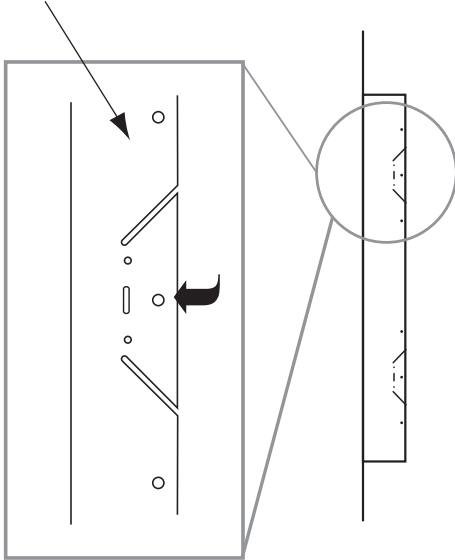
Contractor: _____

Plaster And Drywall Frame

Material: All aluminium construction.



Practical Feature:
Depress quick-tabs to sandwich drywall



✓	Model #	Face Dim. A x B
	PF 1212	14 1/16" x 14 1/16" (355 x 355 mm)
	PF 1224	14 1/16" x 26 3/16" (355 x 655 mm)
	PF 2424	26 3/16" x 26 3/16" (655 x 655 mm)
	PF 4824	50 1/16" x 26 3/16" (1295 x 655 mm)

Finish	
<input type="checkbox"/> /w White (default)	<input type="checkbox"/> Custom _____ (please specify)



Schedule type: _____

Job: _____

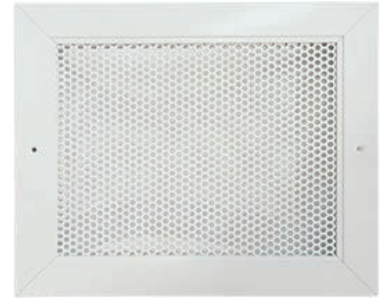
Architect: _____

Engineer: _____

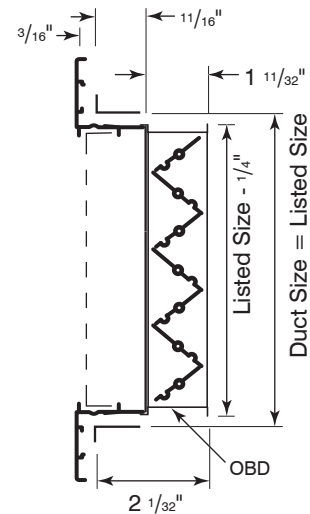
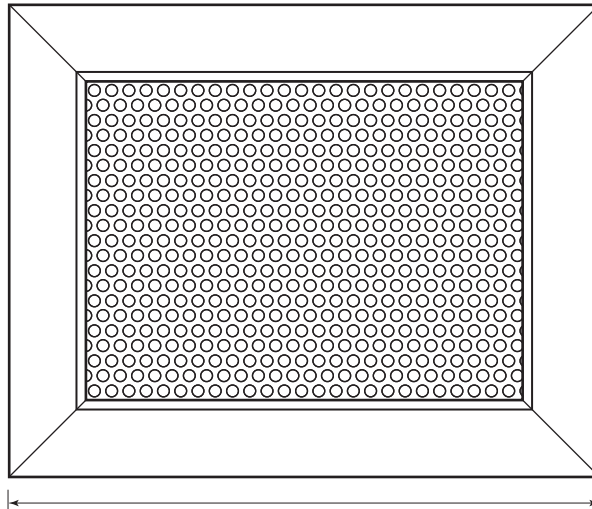
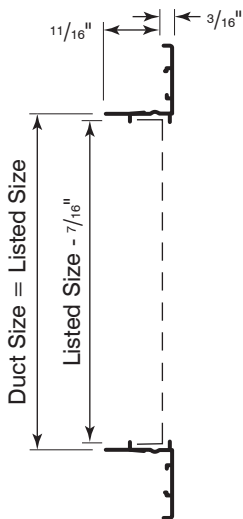
Contractor: _____

Perforated Return Grille

- Material:** Extruded aluminum frame.
Coated steel perforated face with 3/16" diam. round holes on 1/4" staggered centers, affords 53% free area.
- Finish:** Powder paint white finish.
- Mounting:** Drywall mounting. Sidewall or ceiling.



PRE



Options		
-GK Flange Gasket	-GN Neck Gasket	-GR Rear Gasket
-SF Supplied w/ sub frame	-DS Debris (Bird) Screen	-IS Insect Screen

Fastening Method			
-1 No Fastening 	-2 Spring clip 	-3 Screw holes (Standard) 	-6 Adhesive tape

Finish				
<input type="checkbox"/> /W White (default)	<input type="checkbox"/> /B Brushed Aluminum	<input type="checkbox"/> /M Mill Finish	<input type="checkbox"/> /L Brushed & Lacquered	<input type="checkbox"/> /C Custom (Please Specify)



Panel Option for T-bar lay-in Ceiling		
	Steel (WxH)	Aluminum (WxH)
	<input type="checkbox"/> -X1212	<input type="checkbox"/> -Y1212
	<input type="checkbox"/> -X2412	<input type="checkbox"/> -Y2412
	<input type="checkbox"/> -X2424	<input type="checkbox"/> -Y2424
	<input type="checkbox"/> -X4812	<input type="checkbox"/> -Y4812
	<input type="checkbox"/> -X4824	<input type="checkbox"/> -Y4824
	No mounting options available	

Schedule type: _____

Job: _____

Architect: _____

Engineer: _____

Contractor: _____

Perforated Face Return Diffuser with Molded Fiberglass Back Panel Fixed Face

Material: Molded fiberglass back with aluminum foil vapor barrier scored for 6" to 14" D. Steel perforated face with 3/16" diam. holes on 1/4" staggered centers, affords 53% free area.

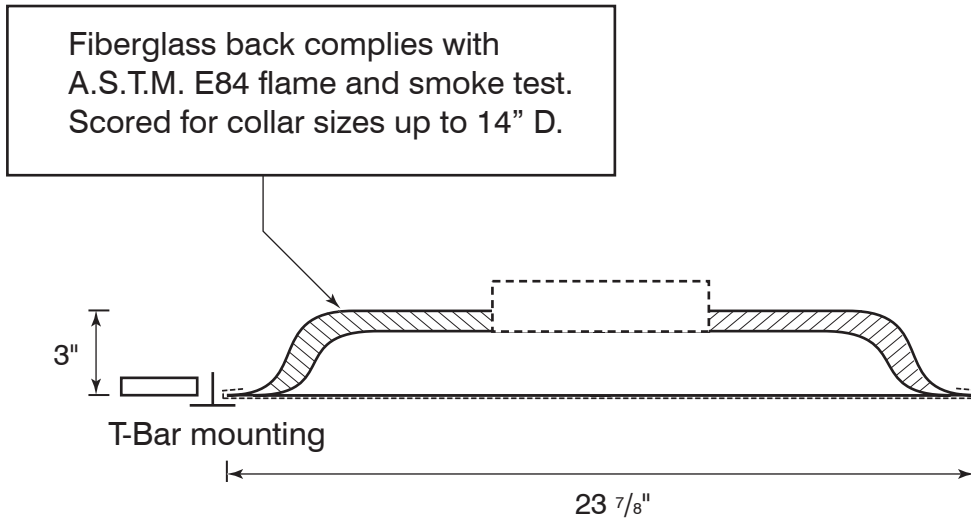
Finish: Powder paint coating - white.

Mounting: Lay-in T-bar ceiling.

Insulation: -R6 Molded Fiberglass.


PRI

SUBMITTAL SHEET



Finish	
<input type="checkbox"/> /W White (default)	<input type="checkbox"/> Custom (please specify)



Schedule type: _____

Job: _____

Architect: _____

Engineer: _____

Contractor: _____

Perforated Face Return Diffuser Fixed face

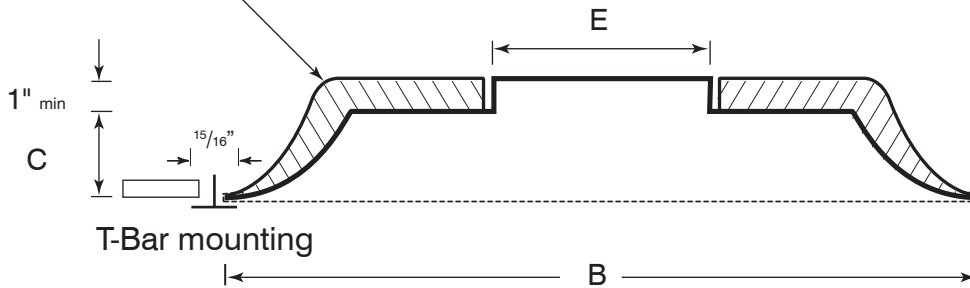
Material: Stamped heavy gauge Aluminium.
Finish: Powder paint coating - white.
Safety: Seismic tabs.
Mounting: Fixed horizontal 360° diffusion.
 Surface or Lay-in T-bar ceiling.



PRM

Optional fiberglass insulation on back panel, complies with A.S.T.M. E84 flame and smoke test. (Available only on models with 24" x 24" face)

-R4 -R6



✓	Model #	Duct Size	E	Face Dim B x B	C
	PRM 1206	6	5 7/8"	11 7/8" x 11 7/8"	1 3/4"
	PRM 1208	8	7 7/8"	11 7/8" x 11 7/8"	1 3/4"
	PRM 2406	6	5 7/8"	23 7/8" x 23 7/8"	2 7/8"
	PRM 2408	8	7 7/8"	23 7/8" x 23 7/8"	2 7/8"
	PRM 2410	10	9 7/8"	23 7/8" x 23 7/8"	2 7/8"
	PRM 2412	12	11 7/8"	23 7/8" x 23 7/8"	2 7/8"
	PRM 2414	14	13 7/8"	23 7/8" x 23 7/8"	2 7/8"

Finish	
<input type="checkbox"/> /W White (Default)	<input type="checkbox"/> /C Custom (Please Specify) _____



Schedule type: _____

Job: _____

Architect: _____

Engineer: _____

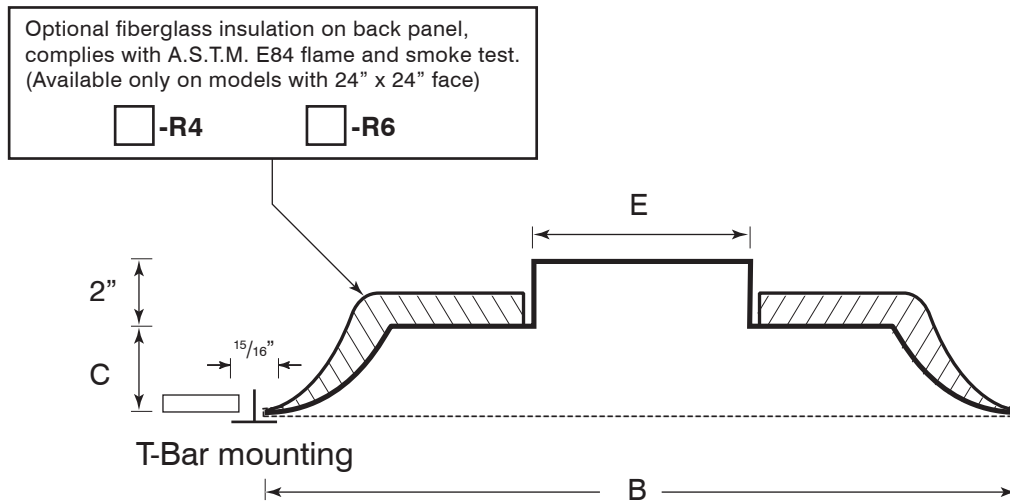
Contractor: _____

Perforated Face Supply Diffuser Fixed face – 2" Collar

Material: Stamped heavy gauge Aluminium.
Finish: Powder paint coating - white.
Safety: Seismic tabs.
Mounting: Fixed horizontal 360° diffusion.
 Surface or Lay-in T-bar ceiling.



SUBMITTAL SHEET

PRMD


✓	Model #	Duct Size	E	Face Dim B x B	C
	PRMD 2406	6	5 7/8"	23 7/8" x 23 7/8"	2 7/8"
	PRMD 2408	8	7 7/8"	23 7/8" x 23 7/8"	2 7/8"
	PRMD 2410	10	9 7/8"	23 7/8" x 23 7/8"	2 7/8"
	PRMD 2412	12	11 7/8"	23 7/8" x 23 7/8"	2 7/8"
	PRMD 2414	14	13 7/8"	23 7/8" x 23 7/8"	2 7/8"
	PRMD 1206	6	5 7/8"	11 7/8" x 11 7/8"	1 3/4"
	PRMD 1208	8	7 7/8"	11 7/8" x 11 7/8"	1 3/4"

Finish	
<input type="checkbox"/> /W White <small>(Default)</small>	<input type="checkbox"/> /C Custom _____ <small>(Please Specify)</small>



Schedule type: _____

Job: _____

Architect: _____

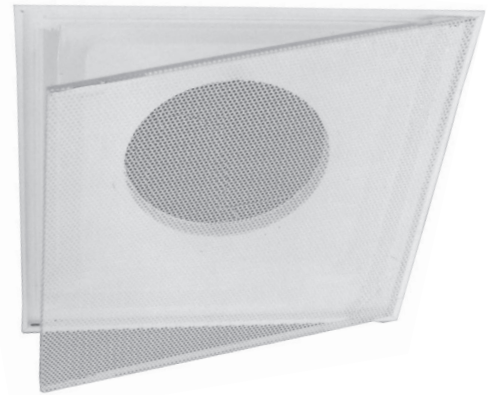
Engineer: _____

Contractor: _____

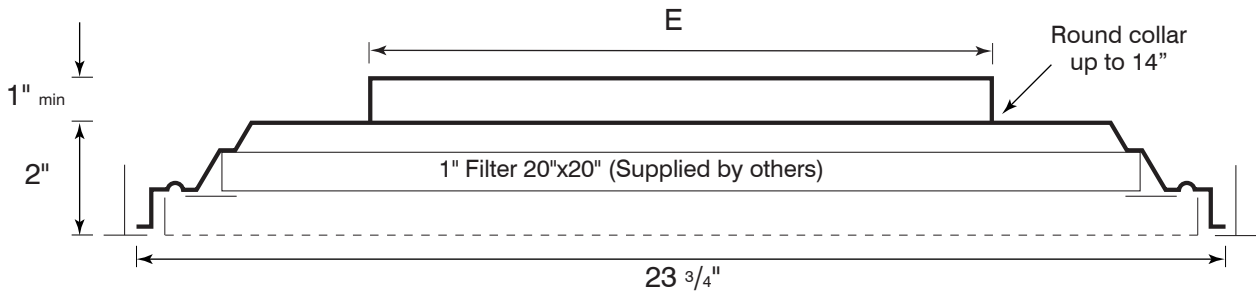
SUBMITTAL SHEET

Perforated Face Filter Return with Steel Back Panel Hinged face

- Material:** Stamped heavy gauge steel back panel with reinforcing corners. Steel perforated face with 3/16" diam. holes on 1/4" staggered centers, affords 53% free area and swings in and out of fixed frame for access to 20"x20" filter by others.
- Finish:** Powder paint coating - white.
- Safety:** Seismic tabs.
- Mounting:** T-bar Lay-in ceiling.



PRMF



✓	Model #	Duct Size	E	Face Dim
	PRMF 2406	6	5 7/8"	23 3/4" x 23 3/4"
	PRMF 2408	8	7 7/8"	23 3/4" x 23 3/4"
	PRMF 2410	10	9 7/8"	23 3/4" x 23 3/4"
	PRMF 2412	12	11 7/8"	23 3/4" x 23 3/4"
	PRMF 2414	14	13 7/8"	23 3/4" x 23 3/4"

Schedule type: _____

Job: _____

Architect: _____

Engineer: _____

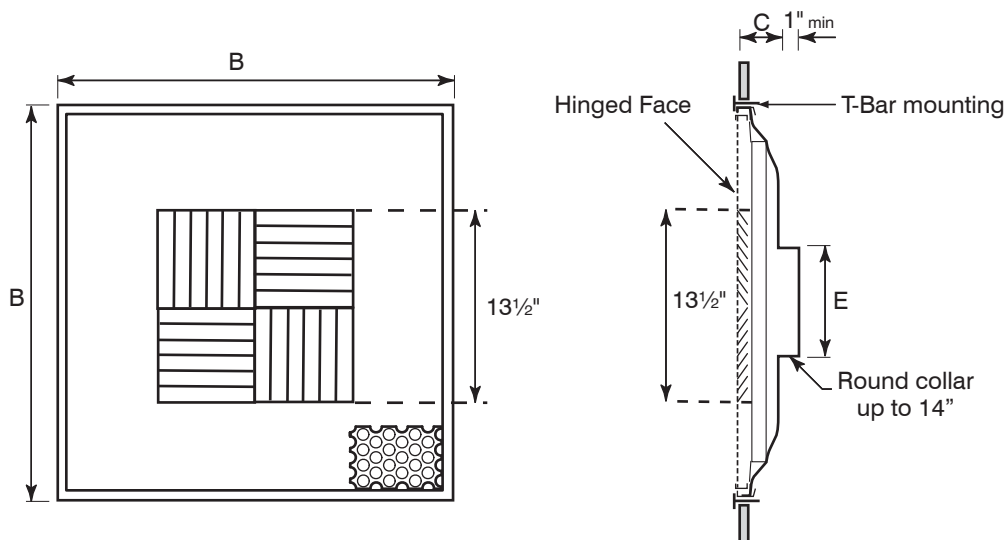
Contractor: _____

Perforated Face Return with Steel Back Panel & Directional Louver Deflectors Hinged Face

- Material:** Stamped heavy gauge steel back panel with reinforcing corners. Steel perforated face with 3/16" diam. holes on 1/4" staggered centers, affords 53% free area and swings in and out of fixed frame for access to 20"x20" filter by others.
- Finish:** Powder paint coating - white.
- Safety:** Seismic tabs.
- Mounting:** T-bar Lay-in ceiling.


PRMFL

SUBMITTAL SHEET

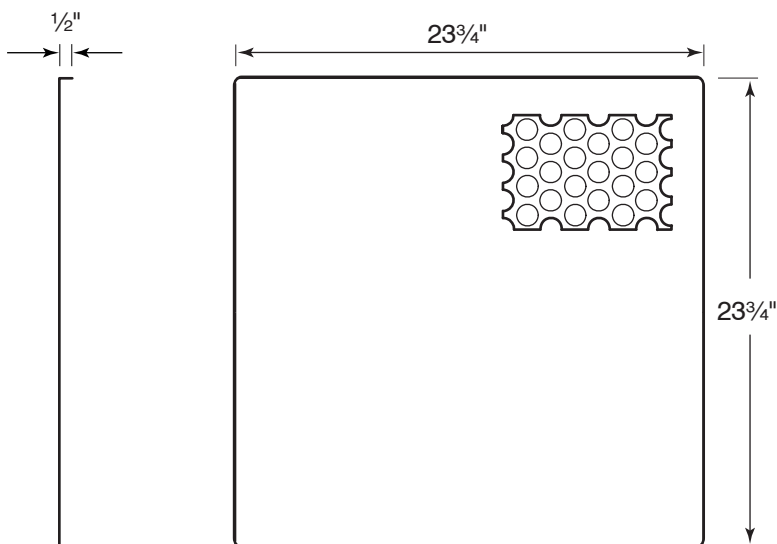


✓	Model #	Duct Size	E	Face Dim
	PRMFL 2406	6	5 7/8"	23 3/4" x 23 3/4"
	PRMFL 2408	8	7 7/8"	23 3/4" x 23 3/4"
	PRMFL 2410	10	9 7/8"	23 3/4" x 23 3/4"
	PRMFL 2412	12	11 7/8"	23 3/4" x 23 3/4"
	PRMFL 2414	14	13 7/8"	23 3/4" x 23 3/4"

Schedule type: _____
Job: _____
Architect: _____
Engineer: _____
Contractor: _____

Ceiling Return Air Diffuser

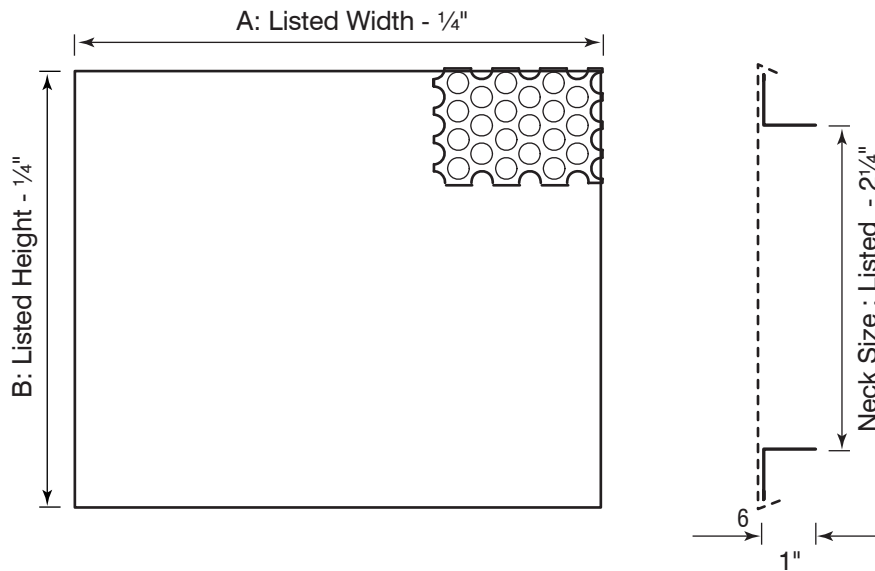
- Material:** Metal face construction
Full face perforated panel with 3/16" holes
on 1/4" staggered and 51% open area.
- Finish:** Bake white paint finish.
- Mounting:** Lay-in T-bar ceiling.



Schedule type: _____
Job: _____
Architect: _____
Engineer: _____
Contractor: _____

Ceiling Return Air Diffuser

- Material:** High capacity all steel construction.
Full face perforated panel with 3/16" holes on 1/4" staggered centres and 51% open area.
- Finish:** Powder paint white finish.
- Mounting:** For surface mounting or T-bar lay-in ceiling grids.



✓	Model #	Face Dim. A x B
	PRT 1212	11 ³ / ₄ " x 11 ³ / ₄ "
	PRT 2412	23 ³ / ₄ " x 11 ³ / ₄ "
	PRT 2424	23 ³ / ₄ " x 23 ³ / ₄ "

Finish		
<input type="checkbox"/> /W White (Default)	<input type="checkbox"/> /M Mill Finish	<input type="checkbox"/> /C Custom (Please Specify)

Schedule type: _____

Job: _____

Architect: _____

Engineer: _____

Contractor: _____



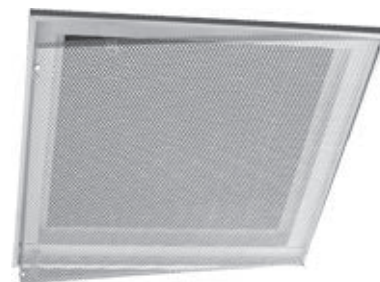
SUBMITTAL SHEET

Perforated Face Filter Return with 20" X 20" Filter Frame Hinged Face

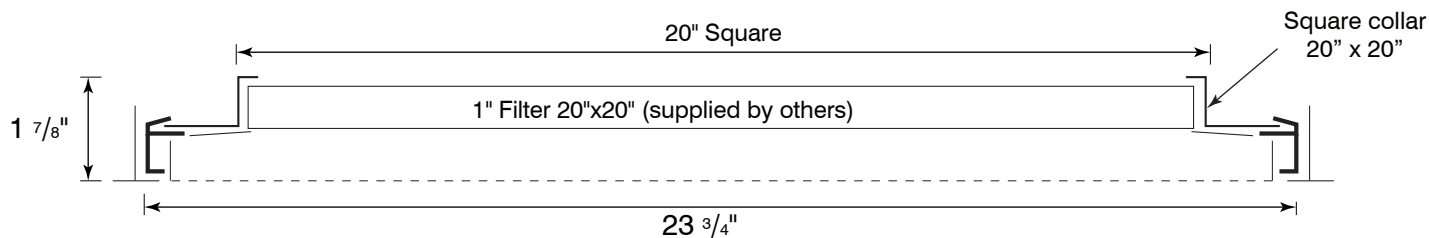
Material: Steel filter frame will accept standard 1" filter. Steel perforated face with 3/16" diam. holes on 1/4" staggered centers, affords 53% free area and swings in and out of fixed frame for access to 20"x20" filter by others.

Finish: Powder paint coating - white.

Mounting: T-bar Lay-in ceiling.



PRTF



Finish	
<input type="checkbox"/> /W	<input type="checkbox"/> /C Custom (Please Specify)
White (Default)	_____



Schedule type: _____

Job: _____

Architect: _____

Engineer: _____

Contractor: _____

Perforated Face Supply Diffuser with Molded Fiberglass Back Panel Fixed Face, Baffle Deflector

Material: Molded fiberglass back with aluminum foil vapor barrier scored for 6" to 14" D. Steel perforated face with 3/16" d iam. holes on 1/4" staggered centers, affords 53% free area.

Finish: Powder paint coating - white.
Air pattern: Fixed horizontal 360° diffusion.

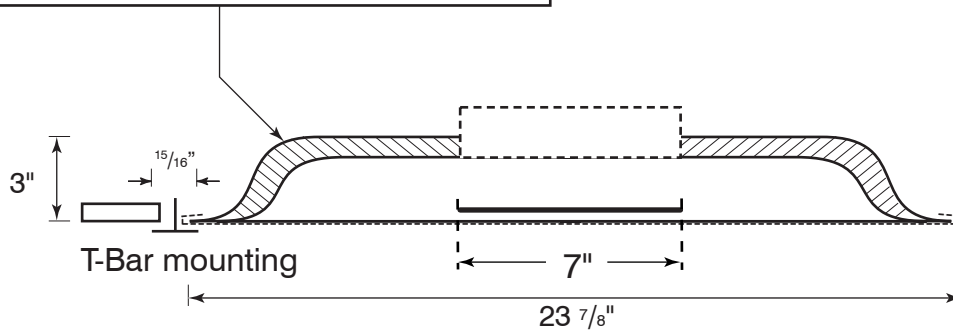
Mounting: Lay-in T-bar ceiling.
Insulation: -R6 Molded Fiberglass.



PSI

SUBMITTAL SHEET

Fiberglass back complies with A.S.T.M. E84 flame and smoke test. Scored for collar sizes up to 14" D.



Mounting	
<input type="checkbox"/> -NT	Narrow T-bar

Finish	
<input type="checkbox"/> /W	White (Default)
<input type="checkbox"/> /C	Custom (Please Specify)



Schedule type: _____

Job: _____

Architect: _____

Engineer: _____

Contractor: _____

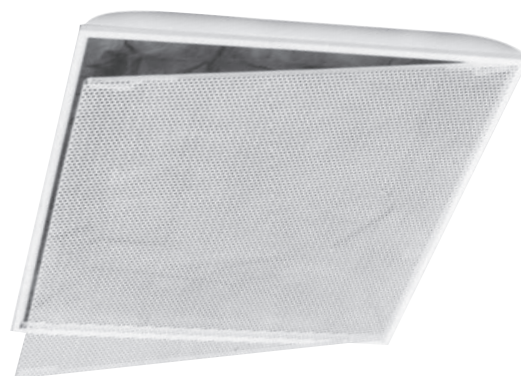
SUBMITTAL SHEET

Perforated Face Filter Supply With Molded Fiberglass Back Panel Hinged Face

Material: Molded fiberglass back with aluminum foil vapor barrier scored for 6" to 14" D. in an extruded aluminum fixed frame. Steel perforated face with 3/16" diam. holes on 1/4" staggered centers, affords 53% free area and swings in and out of fixed frame.

Finish: Powder paint coating - white.

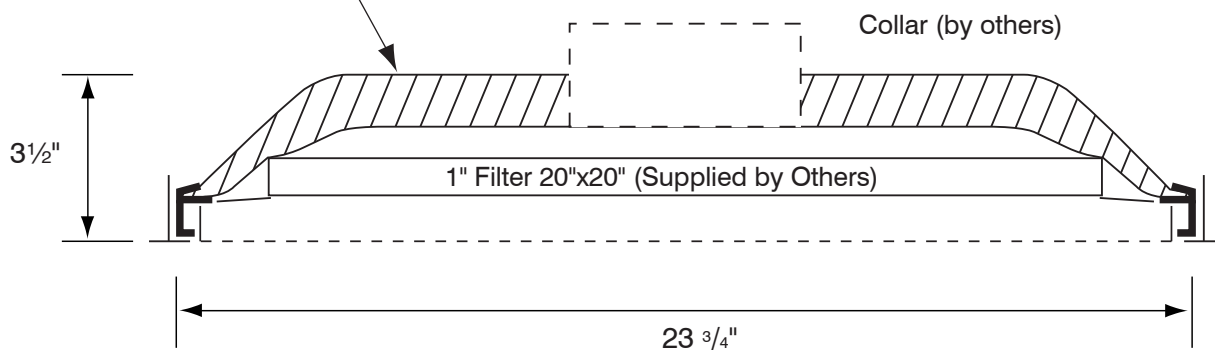
Mounting: T-bar Lay-in ceiling.



PSIF

Fiberglass back complies with A.S.T.M. E84 flame and smoke test. Scored for collar sizes up to 14" D.

-R4 -R6



Finish	
<input type="checkbox"/> /W White (Default)	<input type="checkbox"/> /C Custom (Please Specify) _____



Schedule type: _____

Job: _____

Architect: _____

Engineer: _____

Contractor: _____

Perforated Face Supply With Insulated Back Panel and Directional Louver Deflectors - Hinged Face

Material: Stamped heavy gauge steel back panel with reinforcing corners. Steel perforated face with 3/16" diam. holes on 1/4" staggered centers, affords 53% free area and swings in and out of fixed frame for access to 20"x20" filter by others with -R6 molded fiberglass back.

Finish: Powder paint coating - white.

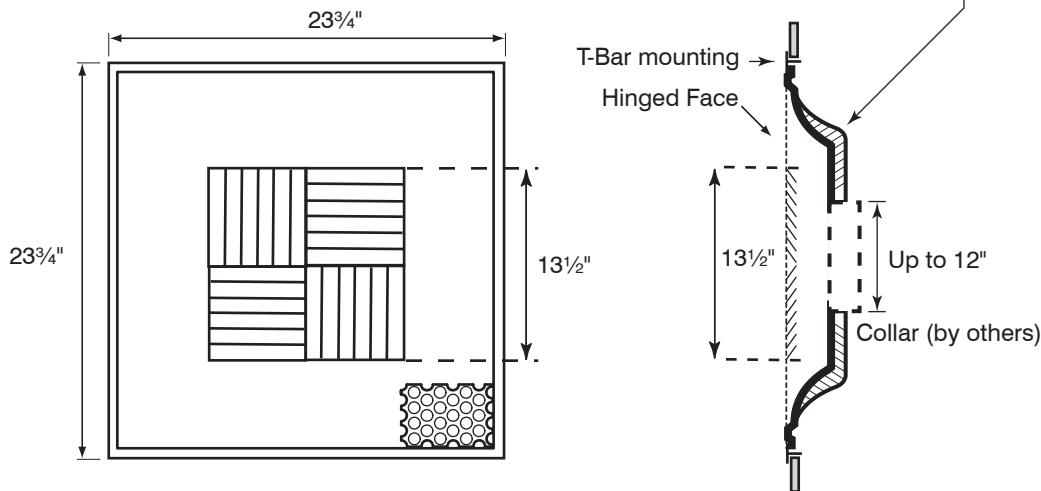
Mounting: T-bar Lay-in ceiling.


PSIFL

SUBMITTAL SHEET

R6 fiberglass back complies with A.S.T.M. E84 flame and smoke test.

Scored for collar sizes up to 12" D. Contractor to install job-specific collar in field. For size 14", please refer to model PRMFL-R6 2414.



Schedule type: _____

Job: _____

Architect: _____

Engineer: _____

Contractor: _____

SUBMITTAL SHEET

Perforated Face Supply Diffuser with Molded Fiberglass Back Panel Fixed Face, Directional Louvers Deflector



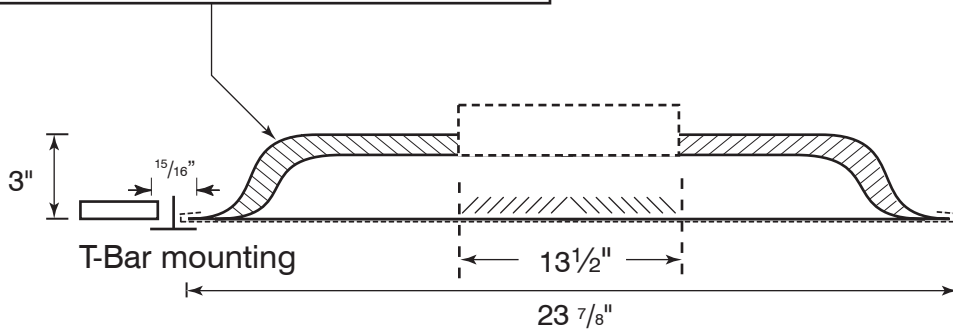
PSIL

Material: Molded fiberglass back with aluminum foil vapor barrier scored for 6" to 14" D. Steel perforated face with 3/16" d iam. holes on 1/4" staggered centers, affords 53% free area.

Finish: Powder paint coating - white.
Air pattern: Fixed horizontal 360° diffusion.

Mounting: Lay-in T-bar ceiling.
Insulation: -R6 Molded Fiberglass.

Fiberglass back complies with A.S.T.M. E84 flame and smoke test. Scored for collar sizes up to 14" D.



Mounting	
<input type="checkbox"/> -NT	Narrow T-bar

Finish	
<input type="checkbox"/> /W	White (Default)
<input type="checkbox"/> /C	Custom (Please Specify)



Schedule type: _____

Job: _____

Architect: _____

Engineer: _____

Contractor: _____

Perforated Face Supply Diffuser Fixed face - baffle deflector

- Material:** Stamped heavy gauge steel back panel.
Coated steel perforated face with 3/16" diam. round holes on 1/4" staggered centers, affords 53% free area.
- Finish:** Powder paint coating - white.
- Air pattern:** Fixed horizontal 360° diffusion.
- Safety:** Seismic tabs.
- Mounting:** Lay-in T-bar ceiling .



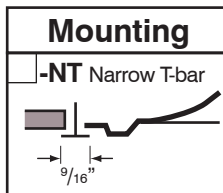
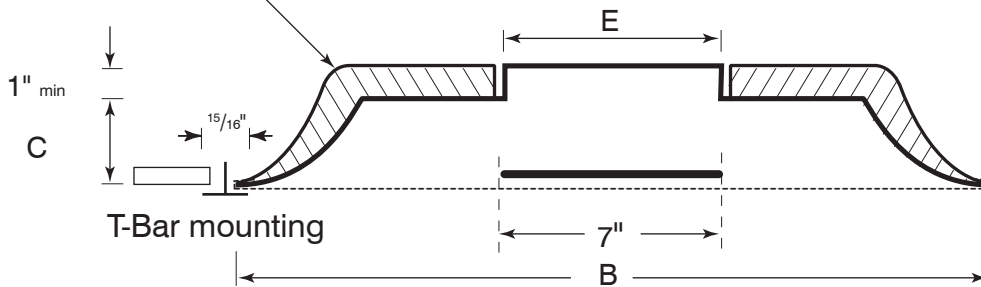
PSM

SUBMITTAL SHEET

Optional fiberglass insulation on back panel, complies with A.S.T.M. E84 flame and smoke test. (Available only on models with 24" x 24" face)

-R4

-R6



✓	Model #	Duct Size	E	Face Dim B x B	C
	PSM 1206	6	5 7/8"	11 3/4" x 11 3/4"	1 3/4"
	PSM 1208	8	7 7/8"	11 3/4" x 11 3/4"	1 3/4"
	PSM 2406	6	5 7/8"	23 7/8" x 23 7/8"	2 7/8"
	PSM 2408	8	7 7/8"	23 7/8" x 23 7/8"	2 7/8"
	PSM 2410	10	9 7/8"	23 7/8" x 23 7/8"	2 7/8"
	PSM 2412	12	11 7/8"	23 7/8" x 23 7/8"	2 7/8"
	PSM 2414	14	13 7/8"	23 7/8" x 23 7/8"	2 7/8"

Finish

/W White (Default) /C Custom (Please Specify)



Schedule type: _____

Job: _____

Architect: _____

Engineer: _____

Contractor: _____

SUBMITTAL SHEET

Perforated Supply Metal Back with Curved Blade Core, 4-way

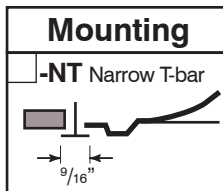
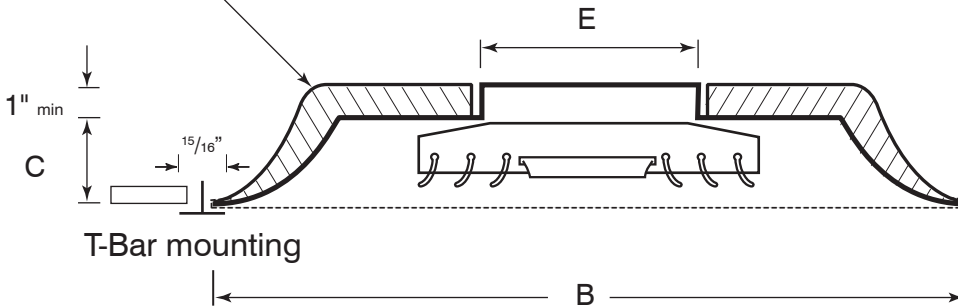
- Material:** Stamped heavy gauge steel back panel. Coated steel perforated face with 3/16" diam. round holes on 1/4" staggered centers, affords 53% free area.
- Finish:** Powder paint coating - white.
- Air pattern:** Fixed horizontal 360° diffusion.
- Mounting:** Lay-in T-bar ceiling.



PSMC

Optional fiberglass insulation on back panel, complies with A.S.T.M. E84 flame and smoke test. (Available only on models with 24" x 24" face)

-R4 -R6



Finish	
<input type="checkbox"/> /W White (Default)	<input type="checkbox"/> /C Custom (Please Specify)



✓	Model #	Duct Size	E	Face Dim B x B	C
	PSMC 2406	6	5 7/8"	23 7/8" x 23 7/8"	2 7/8"
	PSMC 2408	8	7 7/8"	23 7/8" x 23 7/8"	2 7/8"
	PSMC 2410	10	9 7/8"	23 7/8" x 23 7/8"	2 7/8"
	PSMC 2412	12	11 7/8"	23 7/8" x 23 7/8"	2 7/8"
	PSMC 2414	14	13 7/8"	23 7/8" x 23 7/8"	2 7/8"

Schedule type: _____

Job: _____

Architect: _____

Engineer: _____

Contractor: _____

Perforated Face Supply Diffuser with Molded Fiberglass Back Panel Fixed Face, Baffle Deflector

- Material:** Stamped heavy gauge steel back panel. Coated steel perforated face with 3/16" diam. round holes on 1/4" staggered centers, affords 53% free area.
- Finish:** Powder paint coating - white.
- Air pattern:** Fixed horizontal 360° diffusion.
- Safety:** Seismic tabs.
- Mounting:** Lay-in T-bar ceiling.

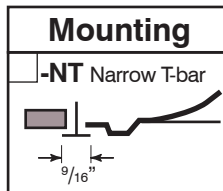
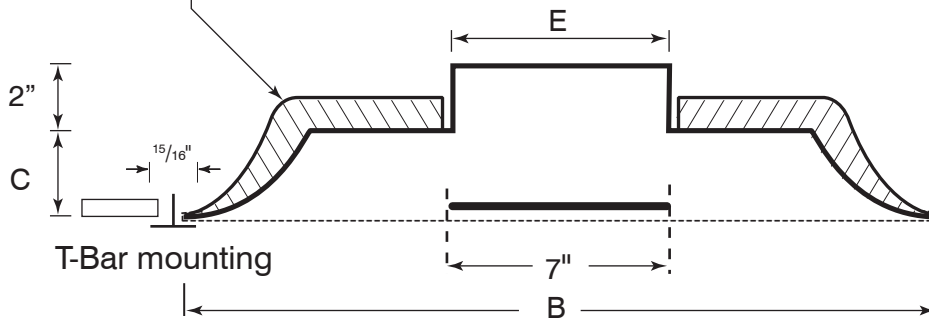


PSMD

SUBMITTAL SHEET

Optional fiberglass insulation on back panel, complies with A.S.T.M. E84 flame and smoke test. (Available only on models with 24" x 24" face)

-R4 -R6



Finish

<input type="checkbox"/> /W White (Default)	<input type="checkbox"/> /C Custom (Please Specify)
---	---



✓	Model #	Duct Size	E	Face Dim B x B	C
	PSMD 2406	6	5 7/8"	23 7/8" x 23 7/8"	2 7/8"
	PSMD 2408	8	7 7/8"	23 7/8" x 23 7/8"	2 7/8"
	PSMD 2410	10	9 7/8"	23 7/8" x 23 7/8"	2 7/8"
	PSMD 2412	12	11 7/8"	23 7/8" x 23 7/8"	2 7/8"

Schedule type: _____

Job: _____

Architect: _____

Engineer: _____

Contractor: _____

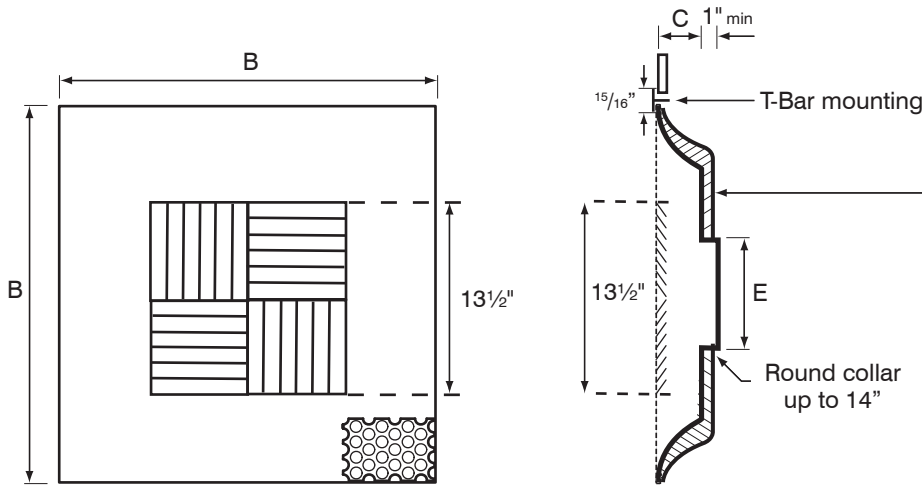
SUBMITTAL SHEET

Perforated Face Supply Diffuser Fixed Face - Directional Louvers Deflectors Fixed Face, Baffle Deflector

- Material:** Stamped heavy gauge steel back panel.
Coated steel perforated face with 3/16" diam. round holes on 1/4" staggered centers, affords 53% free area.
- Finish:** Powder paint coating - white.
- Air pattern:** Fixed horizontal 360° diffusion.
- Safety:** Seismic tabs.
- Mounting:** Lay-in T-bar ceiling.

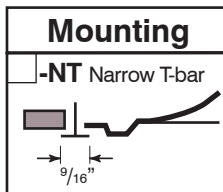


PSML



Optional fiberglass insulation on back panel, complies with A.S.T.M. E84 flame and smoke test. (Available only on models with 24" x 24" face)

-R4 -R6



Finish	
<input type="checkbox"/> /W White (Default)	<input type="checkbox"/> /C Custom (Please Specify)



✓	Model #	Duct Size	E	Face Dim B x B	C
	PSML 2406	6	5 7/8"	23 7/8" x 23 7/8"	2 7/8"
	PSML 2408	8	7 7/8"	23 7/8" x 23 7/8"	2 7/8"
	PSML 2410	10	9 7/8"	23 7/8" x 23 7/8"	2 7/8"
	PSML 2412	12	11 7/8"	23 7/8" x 23 7/8"	2 7/8"
	PSML 2414	14	13 7/8"	23 7/8" x 23 7/8"	2 7/8"

Schedule type: _____

Job: _____

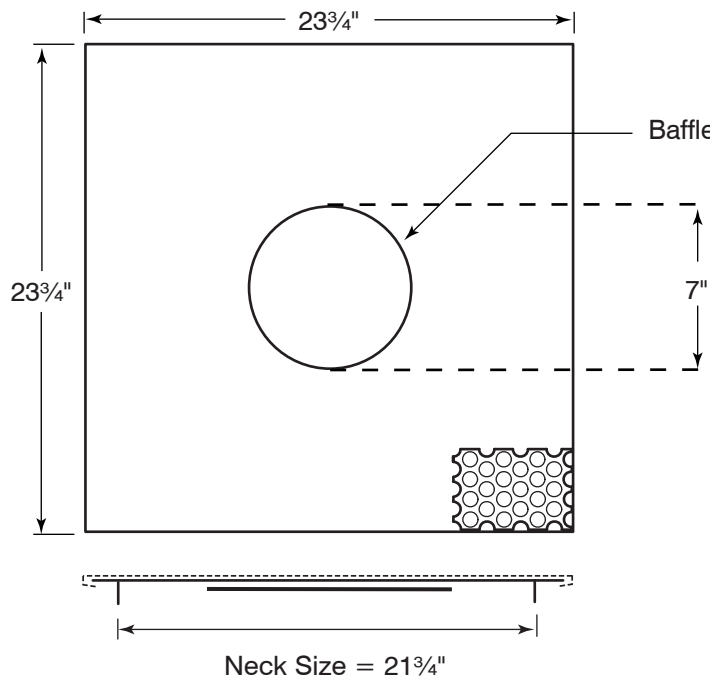
Architect: _____

Engineer: _____

Contractor: _____

Perforated Ceiling Supply Diffuser with Square Neck Fixed Face - Round Baffle Deflector

- Material:** All steel construction.
Full face perforated panel with 3/16" holes on 1/4" staggered centers, affords 53% open area.
Round baffle.
- Air pattern:** Fixed horizontal 360° diffusion.
- Finish:** Powder paint coating - white.
- Mounting:** For surface mounting or T-bar lay-in ceiling grids.



Model #	Neck Size	Face Dim.
PST 2424	21 3/4"	23 3/4" x 23 3/4"

Finish	
<input type="checkbox"/> /W White (Default)	<input type="checkbox"/> /C Custom (Please Specify)



Schedule type: _____

Job: _____

Architect: _____

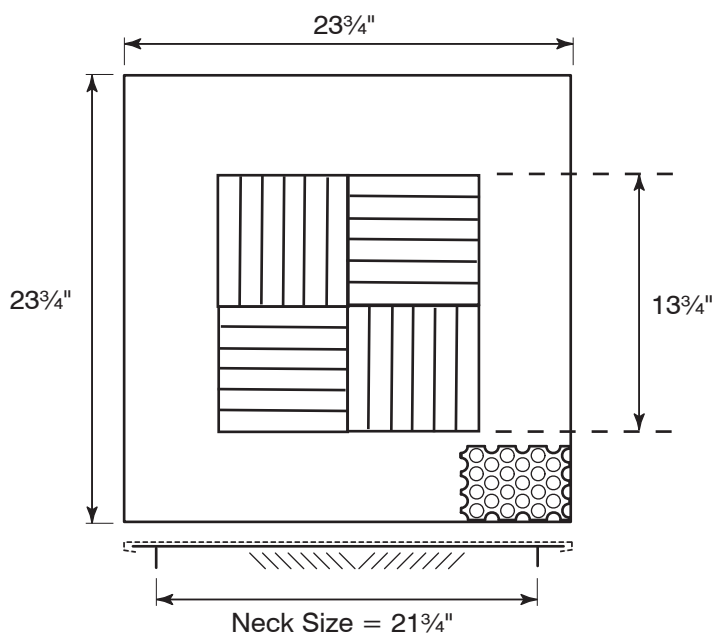
Engineer: _____

Contractor: _____

SUBMITTAL SHEET

Perforated Ceiling Supply Diffuser with Square Neck Fixed Face - Louver Deflectors

- Material:** Full face perforated panel with 3/16" holes on 1/4" staggered centers, affords 53% open area. All steel construction.
- Air pattern:** 4 fixed directional louvers, horizontal 360° diffusion.
- Finish:** Powder paint coating - white.
- Mounting:** For surface mounting or T-bar lay-in ceiling grids.



Model #	Neck Size	Face Dim.
PSTL 2424	21 3/4"	23 3/4" x 23 3/4"

Finish	
<input type="checkbox"/> /W White (Default)	<input type="checkbox"/> /C Custom (Please Specify)



Schedule type: _____

Job: _____

Architect: _____

Engineer: _____

Contractor: _____

High-End Architectural Floor Grilles

- Material:** Stamped heavy gauge Aluminium.
Finish: Brushed Aluminum & Powder Coated Lacquer.
Features: Removable Core, Reinforced for Floor.

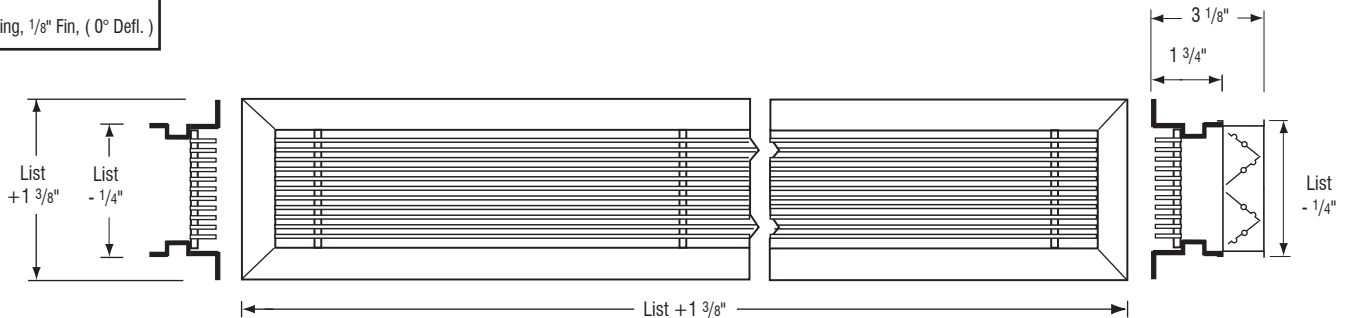
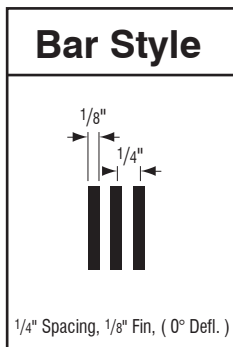


RAF

- Opposed Blade Damper (optional):**
 Galvanized steel construction
 Key-operated

Other Styles Available: Order using ALB model and switch options

Equivalent RAF = ALB10-F-1-RM-RF xx xx /L
 Equivalent RAF7 = ALB17-F-1-RM-RF xx xx /L



RAF Residential Architectural Floor Grille

RAF7 Residential Architectural Floor Register with N7 OBD

✓	Model #	List/Duct Size
	*RAF 0210	2.25" x 10"
	*RAF 0212	2.25" x 12"
	RAF 0310	3" x 10"
	RAF 0312	3" x 12"
	RAF 0408	4" x 8"
	RAF 0410	4" x 10"
	RAF 0412	4" x 12"
	RAF 0414	4" x 14"
	RAF 0612	6" x 12"
	RAF 0614	6" x 14"

✓	Model #	List/Duct Size
	*RAF7 0210	2.25" x 10"
	*RAF7 0212	2.25" x 12"
	RAF7 0310	3" x 10"
	RAF7 0312	3" x 12"
	RAF7 0408	4" x 8"
	RAF7 0410	4" x 10"
	RAF7 0412	4" x 12"
	RAF7 0414	4" x 14"
	RAF7 0612	6" x 12"
	RAF7 0614	6" x 14"

Finish	
<input type="checkbox"/> /W White (Default)	<input type="checkbox"/> /C Custom (Please Specify)



Schedule type: _____

Job: _____

Architect: _____

Engineer: _____

Contractor: _____

SUBMITTAL SHEET

RC1 / RC2 / RC3 / RC4 Series

Rev. 0

All dimensions are in inches

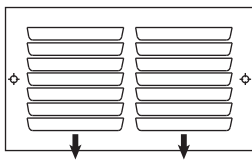
SUBMITTAL SHEET

Stamped Curved Blade Register

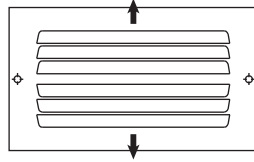
- Material:** Stamped cold-rolled steel.
Integral multi-shutter dampers (MSD).
- Finish:** Powder paint coating - white.
- Mounting:** Drywall or any surface mounting.
Countersunk mounting holes on frame.
- Air Pattern:** 90° Diffusion.
Blades 3/4" spacing.



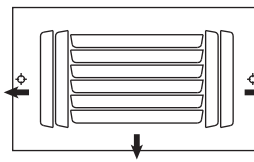
RC1



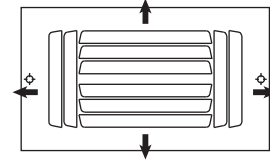
RC1 1 Way



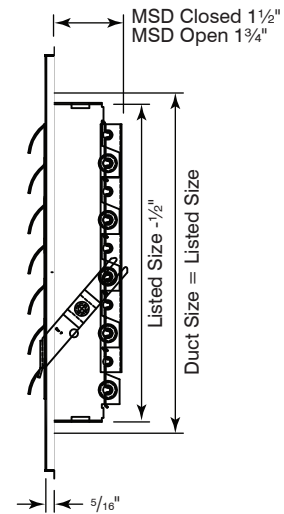
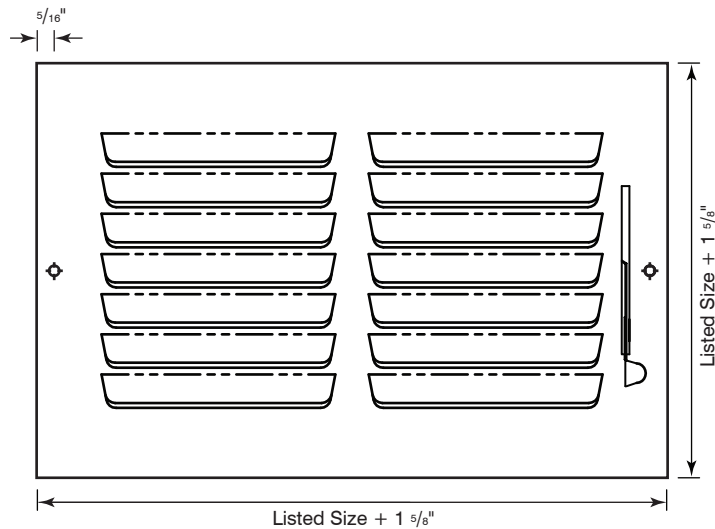
RC2 2 Way



RC3 3 Way



RC4 4 Way



Finish	
<input type="checkbox"/> /W White (Default)	<input type="checkbox"/> /C Custom (Please Specify) _____



Schedule type: _____

Job: _____

Architect: _____

Engineer: _____

Contractor: _____

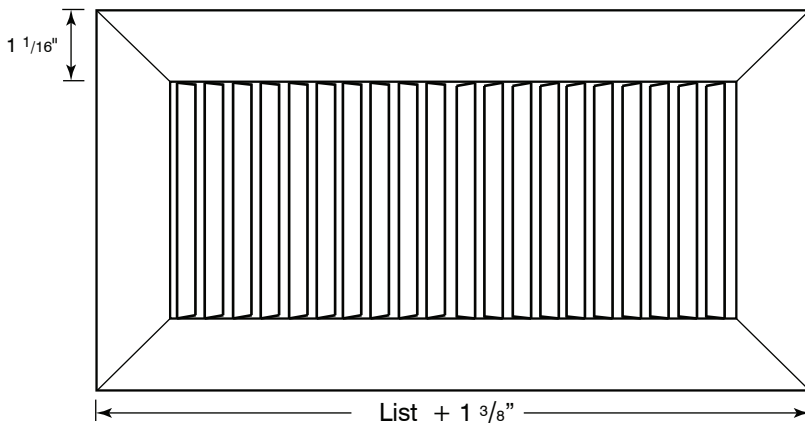
High-End Residential Floor Grilles

- Material:** Extruded heavy gauge Aluminium.
- Finish:** Various finishes available - See Finish Chart.
Anodized finish is standard.
- Air Pattern:** 5 way pattern (-30°, -15°, 0, 15°, 30°)

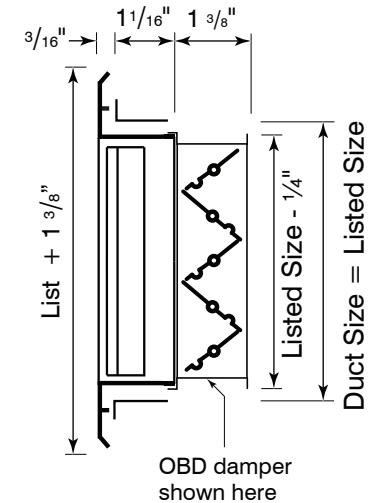


REAL
Residential Floor Grille

SUBMITTAL SHEET



REAL Residential Floor Bar Grille



OBD damper shown here

REAL Residential Floor Bar Grille

✓	Model #	Neck Size
	REAL 0310	3 x 10
	REAL 0408	4 x 8
	REAL 0410	4 x 10
	REAL 0412	4 x 12
	REAL 0414	4 x 14
	REAL 0612	6 x 12
	REAL 0614	6 x 14

REAL7 Residential Floor Bar Register with opposed blade damper

✓	Model #	Neck Size
	REAL7 0310	3 x 10
	REAL7 0408	4 x 8
	REAL7 0410	4 x 10
	REAL7 0412	4 x 12
	REAL7 0414	4 x 14
	REAL7 0612	6 x 12
	REAL7 0614	6 x 14



Finish		
<input type="checkbox"/> /A Anodized (Default)	<input type="checkbox"/> /M Mill Finish	<input type="checkbox"/> /C Custom (Please Specify)

Schedule type: _____

Job: _____

Architect: _____

Engineer: _____

Contractor: _____

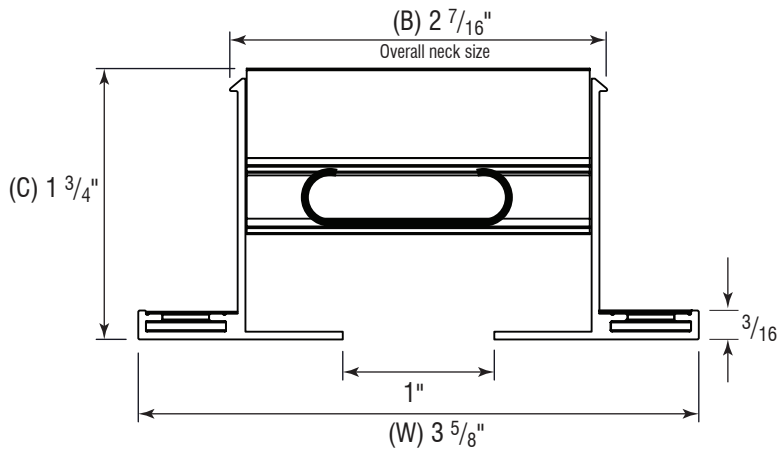
SUBMITTAL SHEET

Residential LineAirFlow Diffuser - 1 Slot

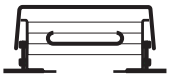
Material: Extruded aluminum construction
Mounting: Surface or Lay-in T-bar ceiling.
 Plaster-in Frame (Tape & Spackle)



RFB10 / RFB17
 (ALF17 shown here)

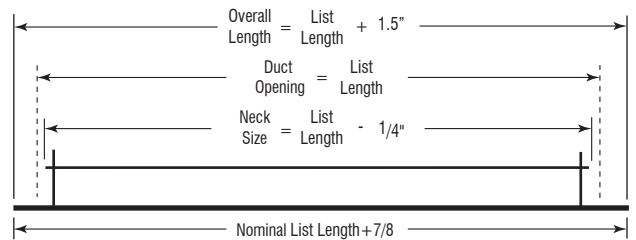


RFB10
 without pattern-control damper



RFB17
 with high-flow slider

Surface mounting (-E option)



Mounting	
<input type="checkbox"/> -E Surface Mounting	<input type="checkbox"/> -T T-Bar mounting
Fastening Method	
<input type="checkbox"/> -1 No Fastening	<input type="checkbox"/> -4 Concealed

Finish	
<input type="checkbox"/> /W White (Default)	<input type="checkbox"/> /C Custom (Please Specify)

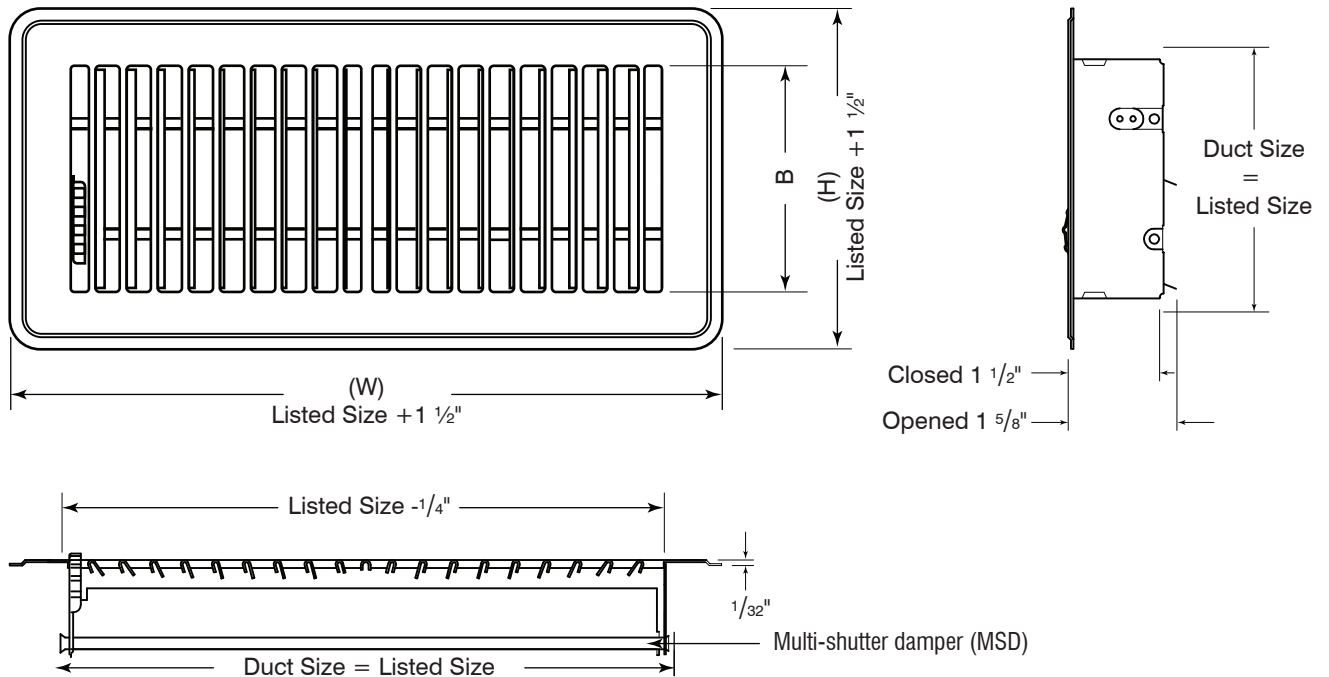


Slot Width	B	W	C
1	2 7/16"	3 5/8"	1 3/4"

Schedule type: _____
 Job: _____
 Architect: _____
 Engineer: _____
 Contractor: _____

Residential Stamped Steel Floor Register

- Material:** Heavy gauge steel.
Finish: Powder paint coating - white or brown
Air Pattern: 180° Diffusion.



✓	Model #	Neck Size	B
	RFG 0408	4 x 8	3 3/4"
	RFG 0410	4 x 10	3 3/4"
	RFG 0412	4 x 12	3 3/4"
	RFG 0414	4 x 14	3 3/4"
	RFG 0610	6 x 10	5 1/2"
	RFG 0612	6 x 12	5 1/2"
	RFG 0614	6 x 14	5 1/2"

Finish	
<input type="checkbox"/> /W White	<input type="checkbox"/> /BR Metallic Brown



Schedule type: _____

Job: _____

Architect: _____

Engineer: _____

Contractor: _____

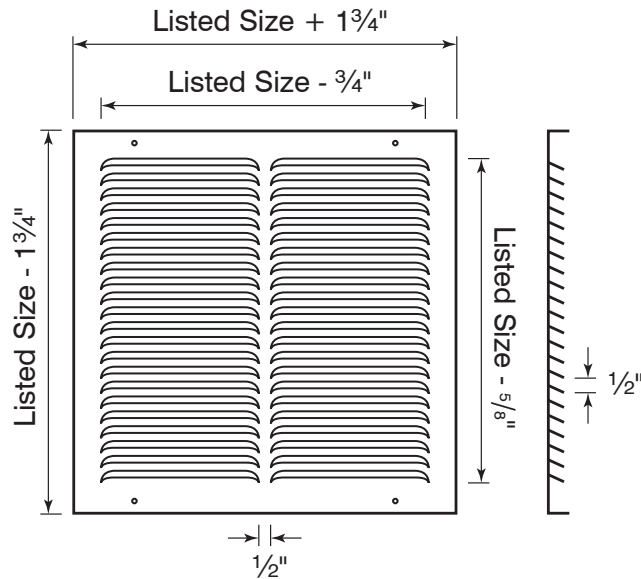
SUBMITTAL SHEET

Residential Stamped Return - Louvered Fixed Air Pattern

- Material:** Stamped heavy gauge steel.
- Finish:** Powder paint coating - white.
- Air Pattern:** Fixed.
- Mounting:** Surface.



RR



Finish	
<input type="checkbox"/> /W White (Default)	<input type="checkbox"/> /C Custom (Please Specify) _____



Schedule type: _____

Job: _____

Architect: _____

Engineer: _____

Contractor: _____

Residential Filter Return - Louvered Fixed Air Pattern

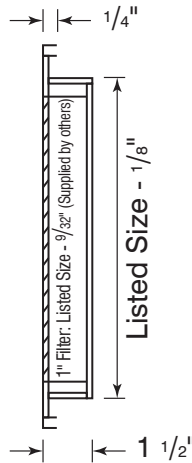
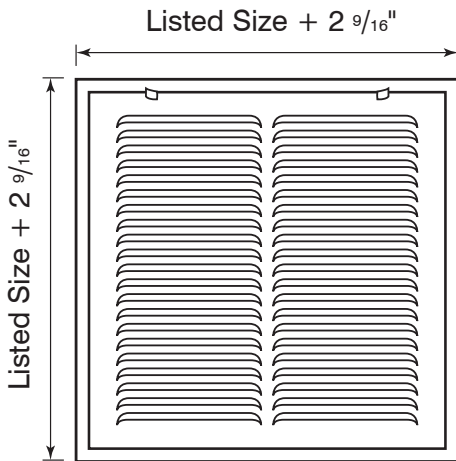
- Material:** Stamped heavy gauge steel.
- Finish:** Powder paint coating - white.
- Air Pattern:** Fixed.
- Mounting:** Surface.



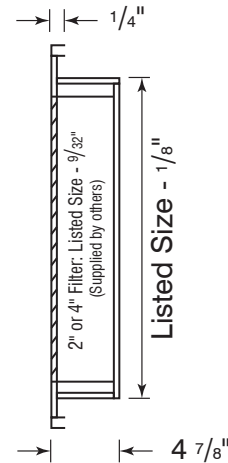
SUBMITTAL SHEET

RRF

Residential Filter Return



RRF for 1" filter



RRF4 for 2" or 4" filter

Finish	
<input type="checkbox"/> /W White (Default)	<input type="checkbox"/> /C Custom (Please Specify)



Schedule type: _____

Job: _____

Architect: _____

Engineer: _____

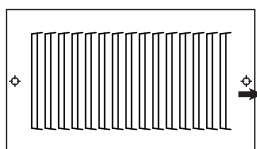
Contractor: _____

Residential Stamped Supply Return - Louvered

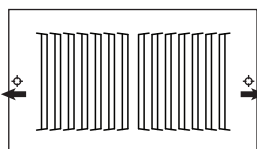
- Material:** Stamped cold-rolled steel.
Integral multi-shutter dampers (MSD).
- Finish:** Powder paint coating - white.
- Mounting:** Drywall or any surface mounting.
Countersunk mounting holes on frame.
- Air Pattern:** 90° Diffusion.
Blades 1/2" spacing.



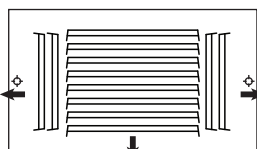
RS1



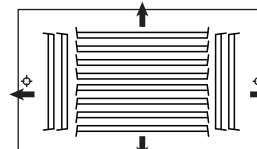
RS1 1 Way



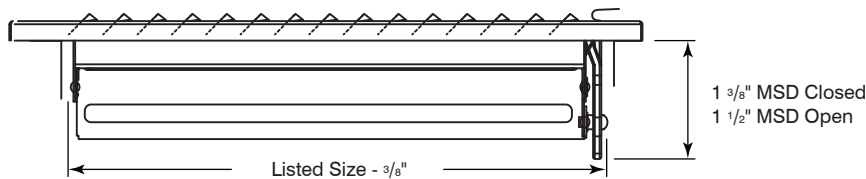
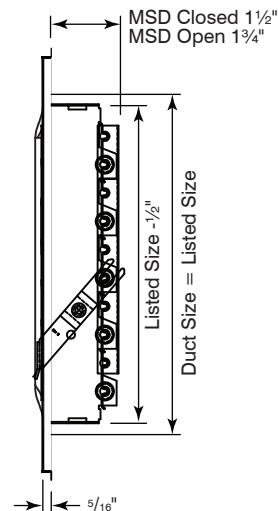
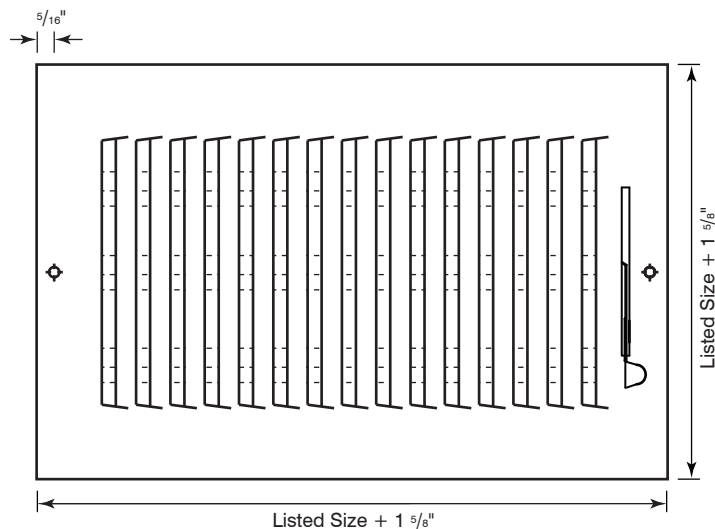
RS2 2 Way



RS3 3 Way



RS4 4 Way



Finish	
<input type="checkbox"/> /W White (Default)	<input type="checkbox"/> /C Custom (Please Specify)



Schedule type: _____

Job: _____

Architect: _____

Engineer: _____

Contractor: _____

Residential T-Bar Filter Return - Louvered Fixed air pattern

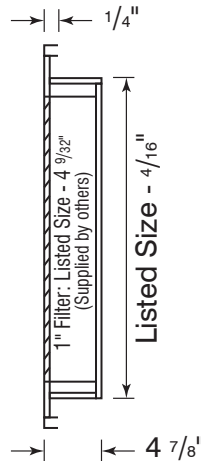
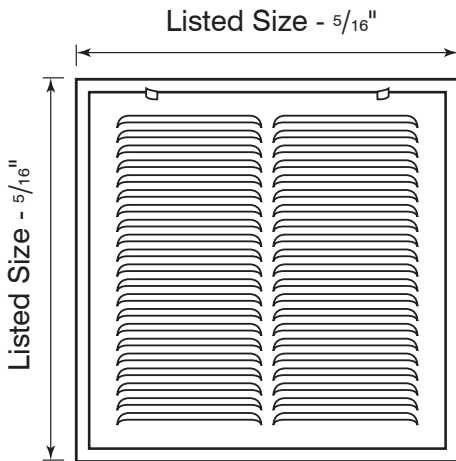
- Material:** Stamped heavy gauge steel.
Finish: Powder paint coating - white.
Air Pattern: Fixed.
Mounting: Lay-in T-bar ceiling.



SUBMITTAL SHEET

RTF

Residential T-Bar Filter Return



Finish	
<input type="checkbox"/> /W White (Default)	<input type="checkbox"/> /C Custom (Please Specify) _____



Schedule type: _____

Job: _____

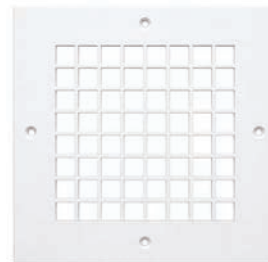
Architect: _____

Engineer: _____

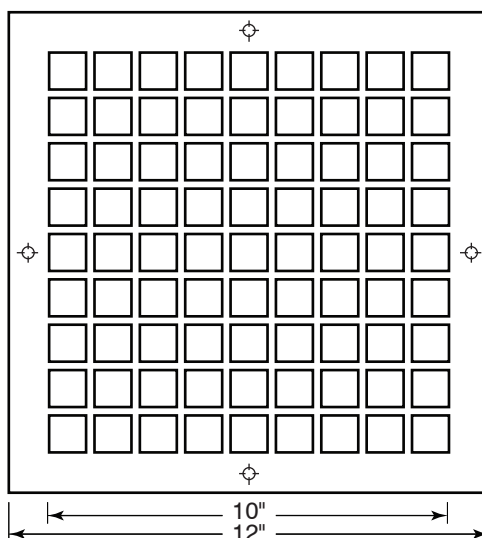
Contractor: _____

Security Lattice Faceplates

- Material:** Galvanized steel.
- Finish:** Powder paint white finish.
- Mounting:** Drywall mounting. Sidewall or ceiling.



TUFL



Finish	
<input type="checkbox"/> /W White (Default)	<input type="checkbox"/> /C Custom (Please Specify) _____



Schedule type: _____

Job: _____

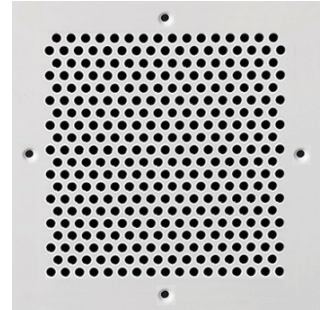
Architect: _____

Engineer: _____

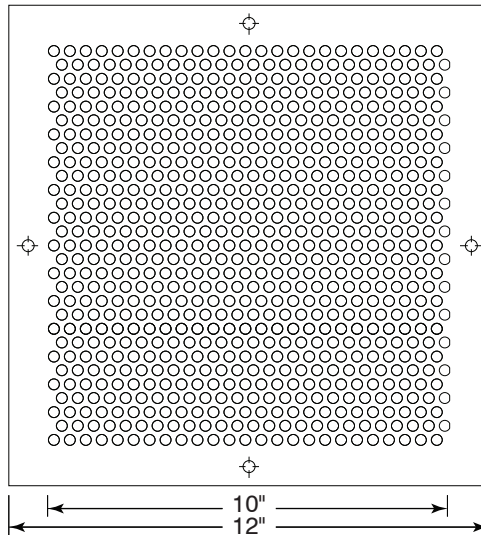
Contractor: _____

Maximum Security Perforated Face

- Material:** Galvanized steel.
 Coated steel perforated face with 3/16" diam. round holes on 1/4" staggered centers, affords 53% free area.
 Square/Rectangular fit to grille.
- Finish:** Powder paint white finish.
- Mounting:** Drywall mounting. Sidewall or ceiling.



SUBMITTAL SHEET



Finish	
<input type="checkbox"/> /W White (Default)	<input type="checkbox"/> /C Custom (Please Specify) _____



Schedule type: _____
Job: _____
Architect: _____
Engineer: _____
Contractor: _____

Aluminum Dampers

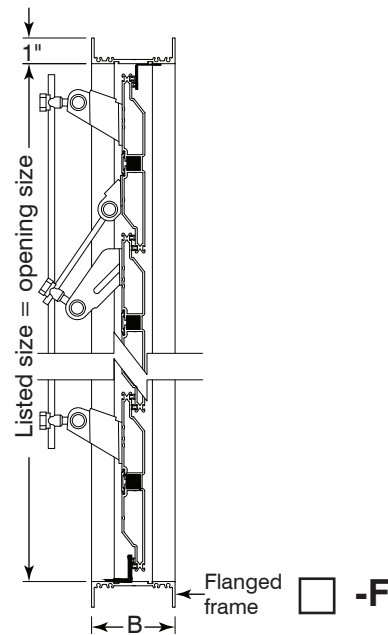
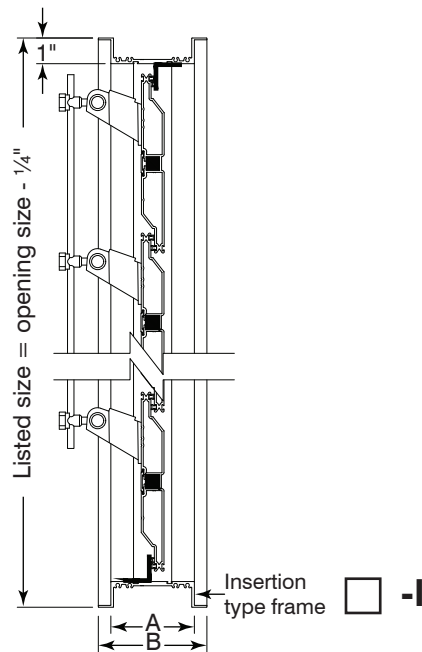
- Material:** All galvanized steel 16 ga. (default).
- Frame:** Extruded 6063-t6 aluminum, 0.102" (2.6 mm) thick.
- Blades:** Extruded 6063-T6 aluminum, 0.08" (2 mm) thick.
- Drive axle:** Machined 1/2" x 1/2" (12.7 mm x 12.7 mm).
Square to \varnothing 1/2" (12.7 mm), round steel bar, bolted.
- Axles:** 1/2" x 1/2" (12.7 mm x 12.7 mm) aluminum bar, punched.
- Frame seals:** Silicone -62 °C to 288 °C (-80 °F TO 550 °F).
- Blade seals:** Silicone -62 °C to 288 °C (-80 °F TO 550 °F).
- Bushings:** Inner part: celcon (polymer).
Outer part: polycarbonate.
- Stoppers:** PVC.
- Hardware:** Yellow zinc plated.



VADF

-PB
Parallel action blades

-OB
Opposed action blades



WIDTH	MIN. 6" (152 mm)	MAX. 60" (1 524 mm)
HEIGHT	SINGLE BLADE	
	-F FLANGED FRAME	-I INSERTION-TYPE FRAME
	MIN. 6-1/2" (165 mm) MAX. 9-3/4" (248 mm)	MIN. 6-1/2" (165 mm) MAX. 11-3/4" (298 mm)
	MULTIPLE BLADES	
	MIN. 12" (305 mm)	MAX. 48" (1 219 mm)

	TYPE	A	B
INSERTION	≤ 30" x 30" (762 x 762)	3 1/8" (79.1 mm)	2 5/16" (58.3 mm)
	>30" x 30" (762 x 762)	4 1/4" (107.4 mm)	3 1/4" (82.6 mm)
FLANGED	≤ 30" x 30" (762 x 762)	-	2 5/16" (58.3 mm)
	>30" x 30" (762 x 762)	-	3 1/4" (82.6 mm)

Schedule type: _____

Job: _____

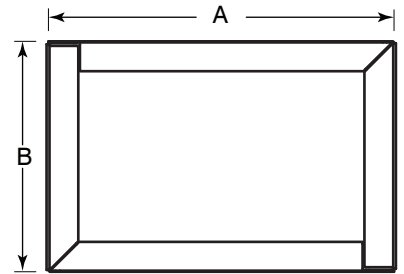
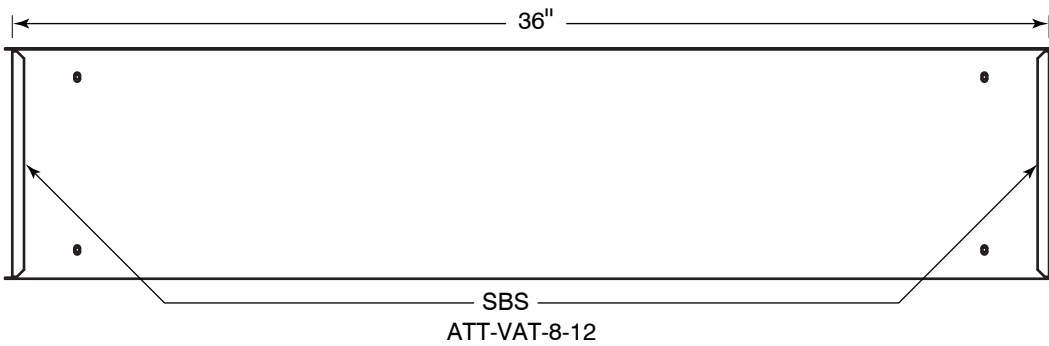
Architect: _____

Engineer: _____

Contractor: _____

Attenuator

Material: 22 ga steel construction.
Insulation: Micromat 1".



Insertion Loss dB @ 1.5" WG												
✓ Model #	A	B	Cfm	63	125	250	500	1000	2000	4000	8000	
VAT 04	12" (305)	8" (203)	150	3	4	6	5	9	18	23	9	
VAT 05	12" (305)	8" (203)	250	3	4	8	6	10	18	24	10	
VAT 06	12" (305)	8" (203)	400	5	6	8	6	11	18	24	11	
VAT 07	12" (305)	8" (203)	550	4	5	7	2	6	17	18	6	
VAT 08	12" (305)	10" (254)	700	5	6	6	4	8	15	32	8	
VAT 09	12" (305)	10" (254)	900	2	3	5	1	6	13	14	6	
VAT 10	14" (356)	12 1/4" (311)	1100	2	3	5	1	6	11	14	6	
VAT 12	14" (356)	12 1/4" (311)	1600	2	2	2	2	5	9	9	5	
VAT 14	16" (406)	15" (381)	2100	1	1	1	3	3	6	8	3	
VAT 16	20" (508)	18" (457)	2800	1	1	1	2	4	6	7	4	
VAT 18	22" (559)	20" (508)	3500	1	2	4	4	8	11	10	4	
VAT 20	24" (610)	22" (559)	4400	1	2	3	3	6	9	9	5	
VAT 22	26" (660)	24" (610)	5300	1	2	3	3	5	7	6	4	

Schedule type: _____

Job: _____

Architect: _____

Engineer: _____

Contractor: _____

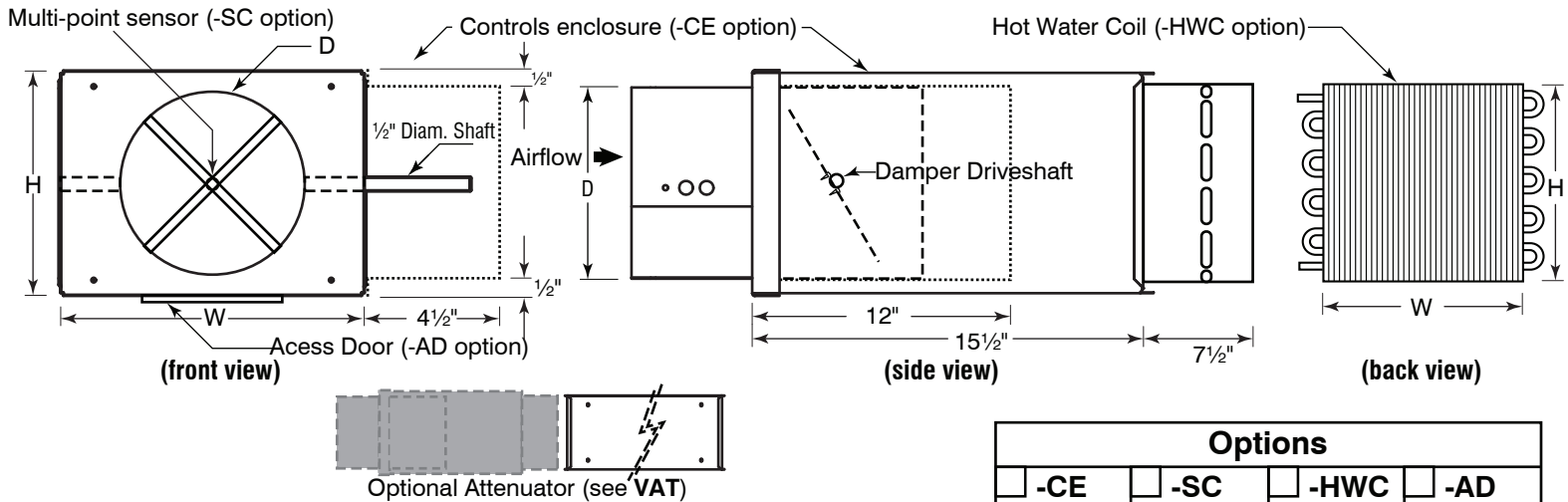
SUBMITTAL SHEET

Variable Volume Terminal Unit

- Material:** 22 gauge galvanized steel.
Sound and thermal insulation 1/2" fiberglass.
2 x 20 ga. with butterfly damper with gasket.
1/2" dia. steel drive shaft.
- Mounting:** Rectangular discharge with slip and drive cleat duct connection.
- Installation:** Horizontally, vertical or any angle.
Operation not affected by position.



VAV



Controls Options			
<input type="checkbox"/> -FLO Field-mounted controls (by others)	<input type="checkbox"/> -FDD Factory digital controls (by others)	<input type="checkbox"/> -FDA Factory digital controls	<input type="checkbox"/> -FPA Factory pneumatic controls

ENGINEERING PERFORMANCE DATA

✓ Model #	Size (D)	W	H	Hot Water Coil (Option)	CFM Cap. Max.	ΔPs
VAV 04	4" (102)	12" (305)	8" (203)	3 Row - 3/8" (10)	150 cfm (71 l/s)	0.1 "WG (25 Pa)
VAV 05	5" (127)	12" (305)	8" (203)	3 Row - 3/8" (10)	175 cfm (83 l/s)	0.1 "WG (25 Pa)
VAV 06	6" (152)	12" (305)	8" (203)	3 Row - 3/8" (10)	300 cfm (142 l/s)	0.13 "WG (33 Pa)
VAV 07	7" (178)	12" (305)	8" (203)	3 Row - 3/8" (10)	400 cfm (189 l/s)	0.13 "WG (33 Pa)
VAV 08	8" (203)	12" (305)	10" (254)	3 Row - 3/8" (10)	525 cfm (248 l/s)	0.11 "WG (28 Pa)
VAV 09	9" (229)	12" (305)	10" (254)	3 Row - 3/8" (10)	650 cfm (307 l/s)	0.1 "WG (25 Pa)
VAV 10	10" (254)	14" (356)	12 1/4" (311)	3 Row - 3/8" (10)	825 cfm (390 l/s)	0.12 "WG (30 Pa)
VAV 12	12" (302)	14" (356)	12 1/4" (311)	3 Row - 3/8" (10)	1200 cfm (567 l/s)	0.13 "WG (33 Pa)
VAV 14	14" (356)	16" (406)	15" (381)	2 Row - 3/8" (10)	1600 cfm (755 l/s)	0.12 "WG (30 Pa)
VAV 16	16" (406)	20" (508)	18" (381)	3 Row - 3/8" (10)	2100 cfm (992 l/s)	0.12 "WG (30 Pa)
VAV 18	18" (457)	22" (559)	20" (457)	2 Row - 3/8" (10)	2500 cfm (1180 l/s)	0.13 "WG (33 Pa)
VAV 20	20" (508)	24" (610)	22" (508)	2 Row - 3/8" (10)	3000 cfm (1416 l/s)	0.13 "WG (33 Pa)
VAV 22	22" (559)	26" (660)	24" (559)	2 Row - 3/8" (10)	3700 cfm (1747 l/s)	0.13 "WG (33 Pa)

ΔPs loss of pressure is measured at nominal volumes maximum with damper fully open.

Options			
<input type="checkbox"/> -CE Control Enclosure	<input type="checkbox"/> -SC Multi-point Sensor with Cross	<input type="checkbox"/> -HWC Hot Water Coil	<input type="checkbox"/> -AD Access Door

Silencers & Attenuators			
<input type="checkbox"/> -AT1 36" Attenuator 1" micromat insulation	<input type="checkbox"/> -AT3 36" Attenuator 1" K-Flex insulation	<input type="checkbox"/> -SIL 36" Silencer	<input type="checkbox"/> -SIM 36" Silencer with Melinex

Insulation Options				
<input type="checkbox"/> -INX without insulation	<input type="checkbox"/> -IN0 (Default) 1/2" Micromat fiberglass insulation	<input type="checkbox"/> -IN1 1" Micromat fiberglass insulation	<input type="checkbox"/> -IN2 1/2" K-Flex free insulation	<input type="checkbox"/> -IN3 1" K-Flex fiber free insulation

Schedule type: _____

Job: _____

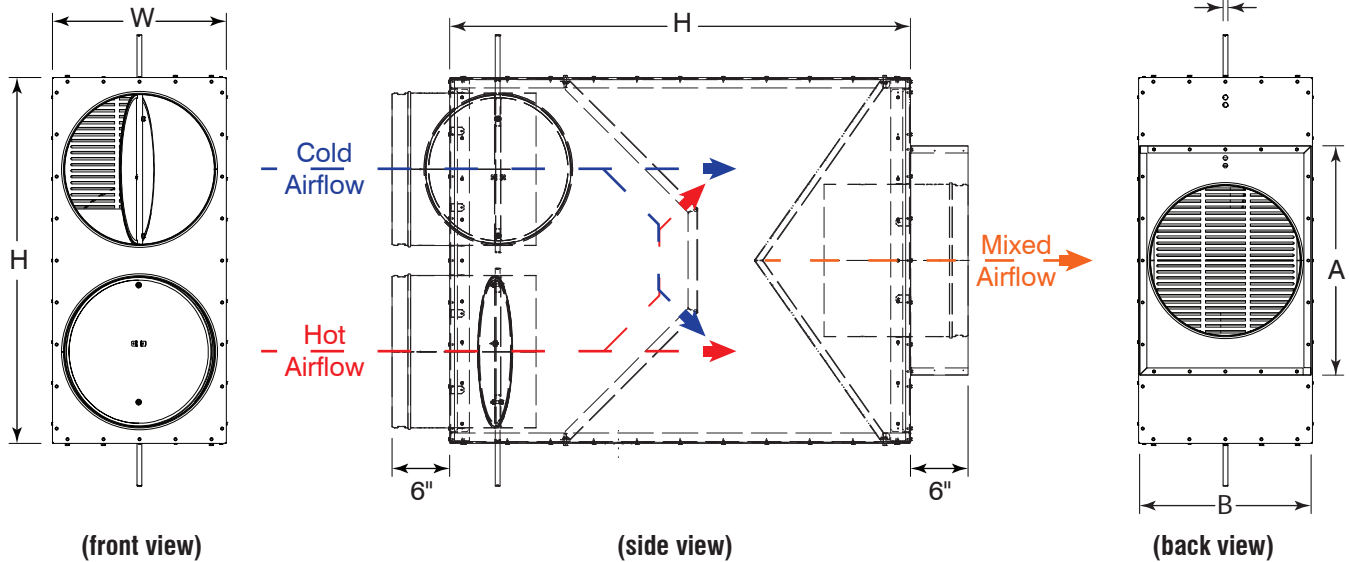
Architect: _____

Engineer: _____

Contractor: _____

Variable Dual-Duct Terminal

- Material:** Caliber casing : 18 ga.
 Caliber collet : 22ga.
 Caliber deflector : 16ga.
 Fiberglass 1", sound and thermal insulation.
- Mounting:** Drive cleat duct connector.
- Installation:** Horizontally, vertical or any angle.
 Operation not affected by position.



ENGINEERING PERFORMANCE DATA

✓ Model #	W in (mm)	H in (mm)	A in (mm)	B in (mm)	CFM Cap. Min.	CFM Cap. Min.
VDT 04	10" (254)	35" (889)	11 ⁷ / ₈ " (12)	7 ⁷ / ₈ " (8)	40 cfm (19 l/s)	200 cfm (94 l/s)
VDT 05	10" (254)	35" (889)	11 ⁷ / ₈ " (12)	7 ⁷ / ₈ " (8)	60 cfm (28 l/s)	300 cfm (142 l/s)
VDT 06	10" (254)	35" (889)	11 ⁷ / ₈ " (12)	7 ⁷ / ₈ " (8)	80 cfm (38 l/s)	400 cfm (189 l/s)
VDT 07	10" (254)	35" (889)	11 ⁷ / ₈ " (12)	9 ⁷ / ₈ " (10)	110 cfm (52 l/s)	600 cfm (283 l/s)
VDT 08	10" (254)	35" (889)	11 ⁷ / ₈ " (12)	9 ⁷ / ₈ " (10)	150 cfm (71 l/s)	800 cfm (378 l/s)
VDT 10	12 ¹ / ₂ " (318)	35" (889)	13 ⁷ / ₈ " (13)	12 ³ / ₈ " (12)	220 cfm (104 l/s)	1300 cfm (614 l/s)
VDT 12	15" (381)	40" (1016)	15 ³ / ₈ " (15)	14 ⁷ / ₈ " (15)	400 cfm (189 l/s)	2000 cfm (944 l/s)
VDT 14	17 ¹ / ₂ " (445)	45" (1219)	19 ⁷ / ₈ " (20)	17 ³ / ₈ " (17)	550 cfm (260 l/s)	3000 cfm (1416 l/s)
VDT 16	18" (457)	45" (1219)	23 ⁷ / ₈ " (24)	17 ⁷ / ₈ " (18)	700 cfm (331 l/s)	4000 cfm (1889 l/s)

Schedule type: _____

Job: _____

Architect: _____

Engineer: _____

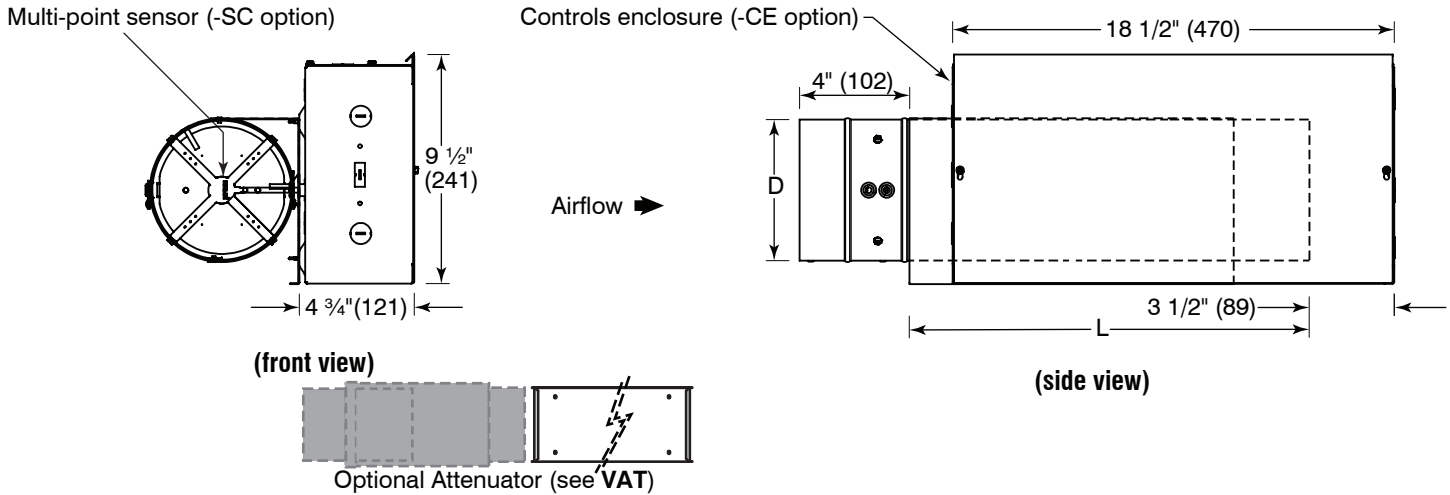
Contractor: _____

Variable Exhaust Volume Terminal Unit

- Material:** 22 gauge galvanized steel.
2 x 20 ga. with butterfly damper with gasket.
1/2" dia. steel drive shaft.
- Mounting:** Round duct connection.
Horizontally, vertical or any angle.
- Installation:** Operation not affected by position.



VEV



Controls Options			
<input type="checkbox"/> -FLO	<input type="checkbox"/> -FDD	<input type="checkbox"/> -FDA	<input type="checkbox"/> -FPA
Field-mounted controls (by others)	Factory digital controls (by others)	Factory digital controls	Factory pneumatic controls
✓ Model #	Size (D)	Length (L)	
VEV 04	4" (98)	23 1/2" (597)	
VEV 05	5" (127)		
VEV 06	6" (152)		
VEV 07	7" (178)		
VEV 08	8" (203)		
VEV 09	9" (229)	29 1/2" (749)	
VEV 10	10" (254)		
VEV 12	12" (302)		
VEV 14	14" (356)	35 1/2" (902)	
VEV 16	16" (406)		
VEV 18	18" (457)		
VEV 20	20" (508)		
VEV 22	22" (559)		

Options	
<input type="checkbox"/> -CE Control Enclosure	<input type="checkbox"/> -SC Multi-point Sensor with Cross

Schedule type: _____

Job: _____

Architect: _____

Engineer: _____

Contractor: _____

Back-Draft Round Dampers

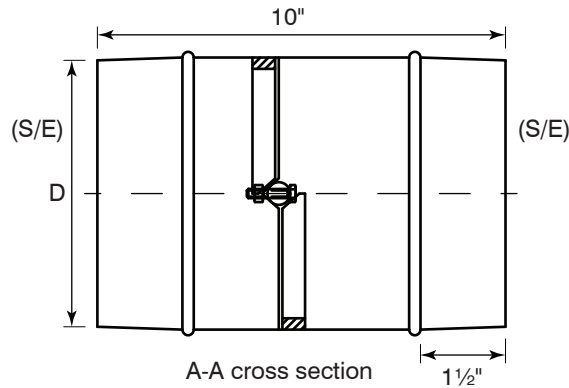
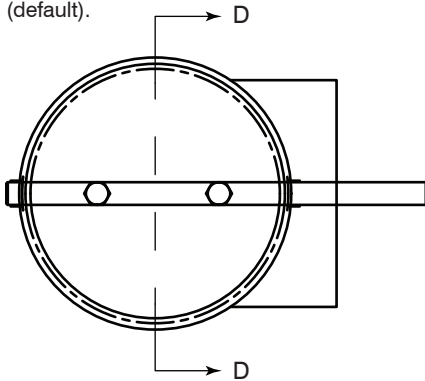
- Material:** 22 gauge galvanized steel frame.
16 gauge galvanized steel blade with gasket.
1/2" dia. steel drive shaft.
- Mounting:** Drive cleat duct connection.
- Installation:** Horizontally, vertical or any angle.
Operation not affected by position.



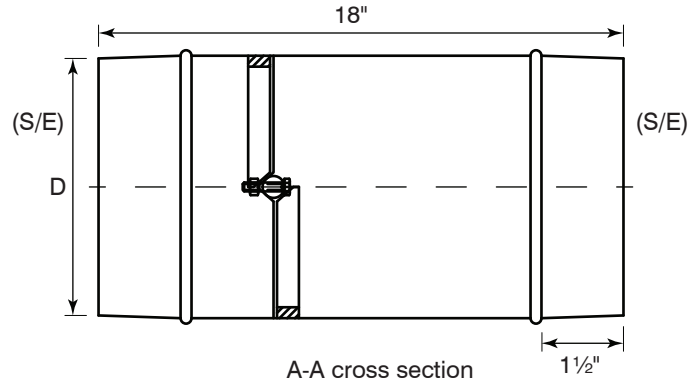
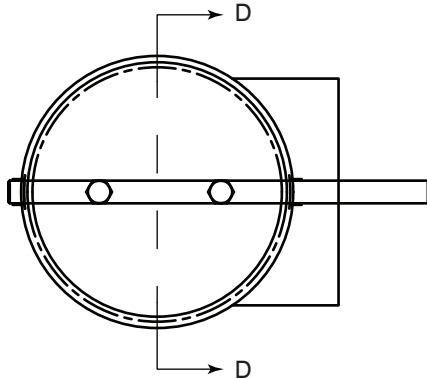
SUBMITTAL SHEET

VRD-10H / VRD-18H

- VRD-10H**
10" height (default).



- VRD-18H**
18" height.



✓	Model #	Size (D) in (mm)
	VRD 04	4" (102)
	VRD 05	5" (127)
	VRD 06	6" (152)
	VRD 07	7" (178)
	VRD 08	8" (203)
	VRD 09	9" (229)
	VRD 10	10" (254)
	VRD 12	12" (305)
	VRD 14	14" (356)
	VRD 16	16" (406)

Schedule type: _____

Job: _____

Architect: _____

Engineer: _____

Contractor: _____

SUBMITTAL SHEET

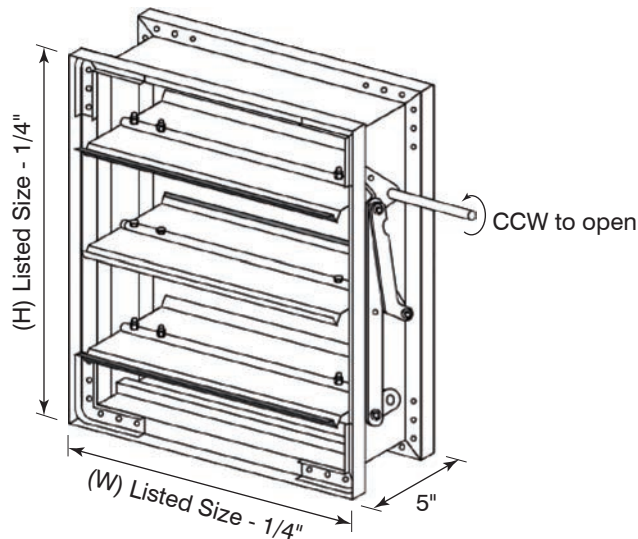
Seals Air Control Damper

- Material:** 16 ga, galvanized steel.
- Frame:** 5" x 1" channel frame construction with die-formed corner gussets.
- Blades:** 3 "V" formed Parallel or Opposed closure action.
- Bearings:** Nylon, (standard).
Sintered bronze, oil impregnated (optional).
- Axles:** 1/2" Square zinc plated steel.
- Linkage:** Zinc plated steel concealed in the channel frame.
- Finish:** Mill galvanized.



Available in single-section sizes from 8" x 8" to 60" x 60"

VSCDA



Blades		
<input type="checkbox"/> -PB Parallel Action blades (Default)	<input type="checkbox"/> -OB Opposed Action blades (option)	
Options		
<input type="checkbox"/> -BS Blade Seals	<input type="checkbox"/> -JS Jamb Seals	
Extended Shafts		
<input type="checkbox"/> -S3 3" Ext Shafts	<input type="checkbox"/> -S6 6" Ext Shafts	<input type="checkbox"/> -S11 11" Ext Shafts

Schedule type: _____
Job: _____
Architect: _____
Engineer: _____
Contractor: _____

Steel Dampers

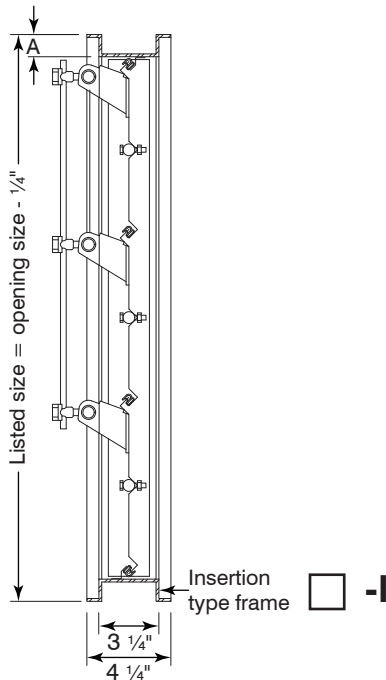
- Material:** All galvanized steel 16 ga. (default).
- Frame:** 16 ga galvanized steel.
- Blades:** 16 ga galvanized steel.
- Drive axle:** cold rolled steel – zinc plated.
- Axles:** bolted zamak sliding swivel \varnothing 1/2" (12.7 mm) of 2-3/4" (70 mm) long.
- Frame seals:** stainless steel.
- Blade seals:** e.p.d.m. rubber.
- Bushings:** delrin (polymer). permanent lubrication.
- Stoppers:** steel.
- Hardware:** yellow zinc plated.



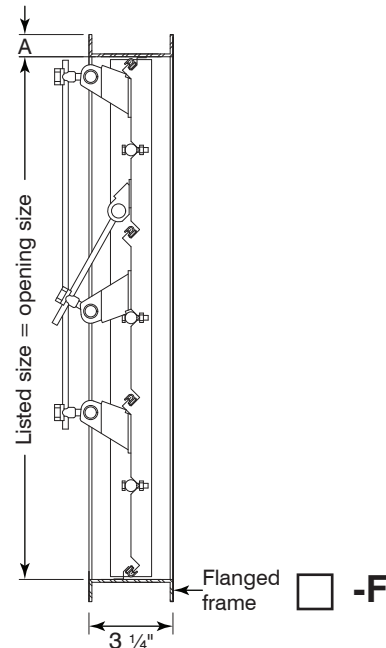
VSDF

SUBMITTAL SHEET

-PB
Parallel action blades



-OB
Opposed action blades



Model #	Height	C
-OB	< 14 ⁷ / ₈ "	5/8"
	≥ 15"	1"
-PB	< 12 ⁵ / ₈ "	5/8"
	≥ 12 ³ / ₄ "	1"

WIDTH	MIN. 6" (152 MM)	MAX. 54" (1 372 MM)
HEIGHT	MIN. 10" (254 MM)	MAX. 48" (1 219 MM)

Schedule type: _____

Job: _____

Architect: _____

Engineer: _____

Contractor: _____

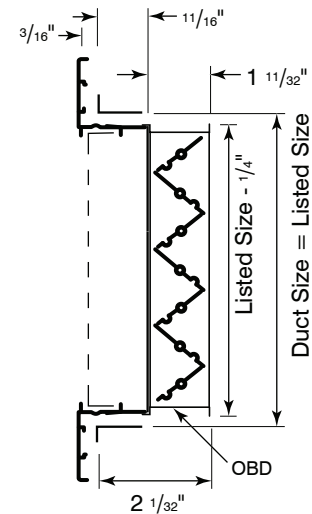
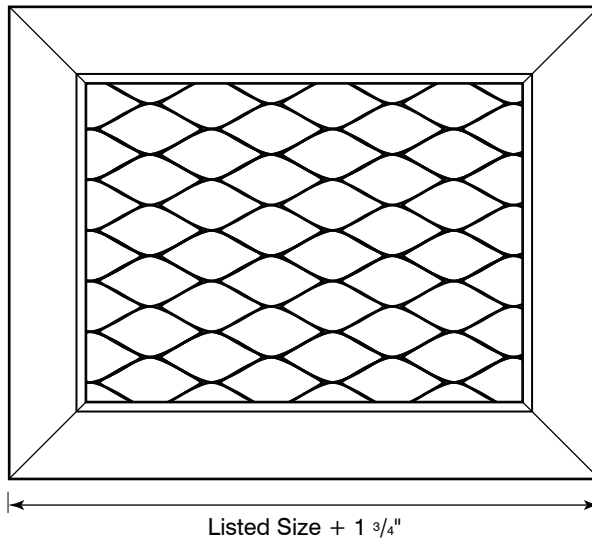
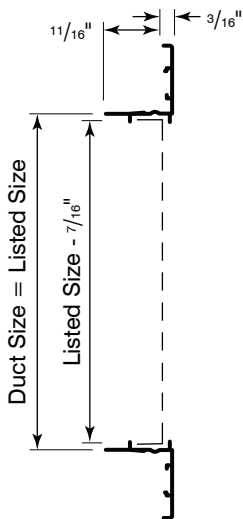
Expanded Metal Mesh Return Grille

- Material:** Extruded aluminum frame.
Expanded metal, affords 84% free area.
- Finish:** Powder paint white finish.
- Mounting:** Drywall mounting. Sidewall or ceiling.



XRE

- XRE** without OBD damper
- XRE7** with OBD damper



Options		
-GK Flange Gasket	-GN Neck Gasket	-GR Rear Gasket
-SF Supplied w/ sub frame	-DS Debris (Bird) Screen	-IS Insect Screen

Fastening Method				
-1 No Fastening 	-2 Spring clip 	-3 Screw holes (Standard) 	-4 Concealed 	-6 Adhesive tape

Finish				
<input type="checkbox"/> /W White (default)	<input type="checkbox"/> /B Brushed Aluminum	<input type="checkbox"/> /M Mill Finish	<input type="checkbox"/> /L Brushed & Lacquered	<input type="checkbox"/> /C Custom (Please Specify)



Panel Option for T-bar lay-in Ceiling		
	Steel (WxH)	Aluminum (WxH)
	<input type="checkbox"/> -X1212	<input type="checkbox"/> -Y1212
	<input type="checkbox"/> -X2412	<input type="checkbox"/> -Y2412
	<input type="checkbox"/> -X2424	<input type="checkbox"/> -Y2424
	<input type="checkbox"/> -X4812	<input type="checkbox"/> -Y4812
	<input type="checkbox"/> -X4824	<input type="checkbox"/> -Y4824

No mounting options available

Schedule type: _____

Job: _____

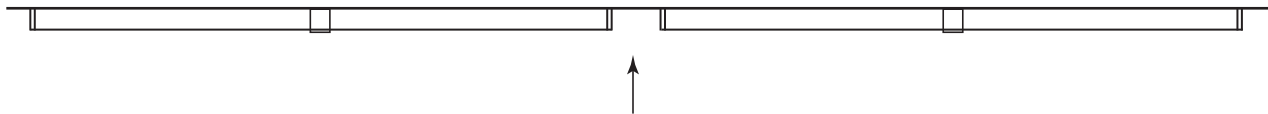
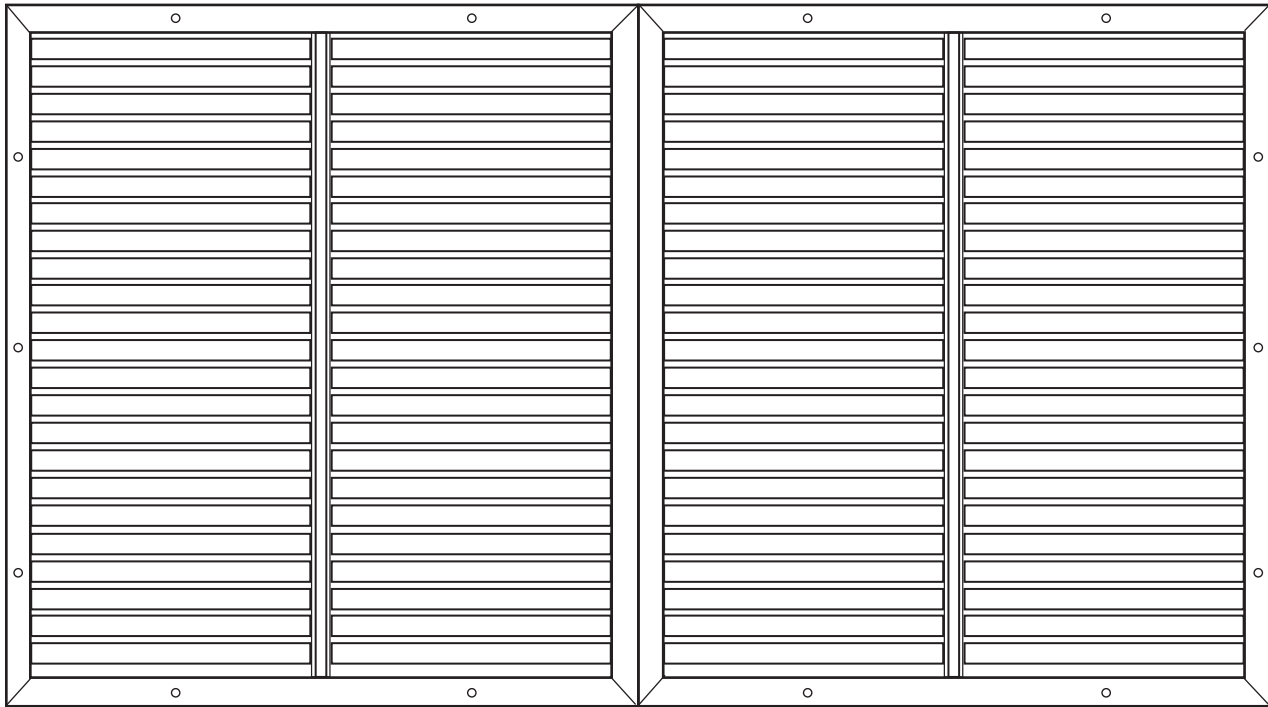
Architect: _____

Engineer: _____

Contractor: _____

Large Grilles in Multiple Sections

No screw holes on interior joined frames by default
Screw holes can be added if clearly specified on order



Support required for proper installation by others
Not provided by Airvector

Notes

- Maximum section size: 46" x 36" (neck)
- Maximum width without mullion: 18"
- Larger grilles can be made in one piece, extra manufacturing and shipping charges apply

SQUARE DIFFUSERS



MODELS ADF3, ADF3D & ADF3I 3 CONE ALUMINUM DIFFUSERS

- MODEL **ADF3** - Fixed horizontal pattern
- MODEL **ADF3D** - Fixed horizontal pattern, 2" high collar
- MODEL **ADF3I** - Fixed horizontal pattern, Insulated

Airvector's 3 Cone Aluminum Supply Diffusers are recommended for heating, ventilating, and cooling. The diffusers' integrated round-neck-to-square-face construction provides a 360° horizontal air diffusion pattern similar to a full round diffuser. The ADF3I is supplied with R6 insulation and does not include an integrated collar. R4 and R6 are optional for ADF3 and ADF3D.

High diffusion induction rates result in rapid temperature and velocity equalization of the mixed air mass well above the zone of occupancy. Horizontal performance assures confident use of a cooling temperature differential of 30° and greater at a predicted low air motion of 35 fpm in the zone of occupancy. ADF3 supply diffusers perform efficiently with air loadings of 6 to 30 air changes per hour (based on a 10 ft. ceiling height), and a sound level range of NC 25 to 35.

Highlights

- Heavy-gauge all-aluminum construction
- Powder paint coating - White (Custom Finishes Avail.)
- Matching N4 and N5 OBDs available
- OBD accessible through diffuser face

Listed Size	Neck Dia	Nominal Face Size	Overall Face Size "B"	Drywall Ceiling Opening
1206*	6	12 x 12	11 ³ / ₄ x 11 ³ / ₄	10 ¹ / ₂ x 10 ¹ / ₂
1208*	8	12 x 12	11 ³ / ₄ x 11 ³ / ₄	10 ¹ / ₂ x 10 ¹ / ₂
2406	6	24 x 24	23 ³ / ₄ x 23 ³ / ₄	22 ¹ / ₂ x 22 ¹ / ₂
2408	8	24 x 24	23 ³ / ₄ x 23 ³ / ₄	22 ¹ / ₂ x 22 ¹ / ₂
2410	10	24 x 24	23 ³ / ₄ x 23 ³ / ₄	22 ¹ / ₂ x 22 ¹ / ₂
2412	12	24 x 24	23 ³ / ₄ x 23 ³ / ₄	22 ¹ / ₂ x 22 ¹ / ₂
2414*	14	24 x 24	23 ³ / ₄ x 23 ³ / ₄	22 ¹ / ₂ x 22 ¹ / ₂

* Only available with ADF3

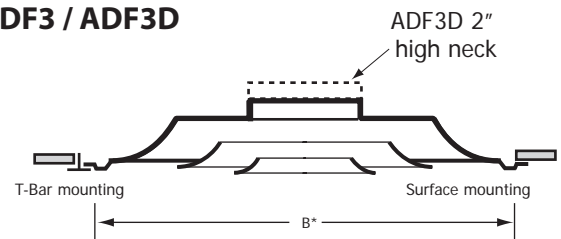


ADF3

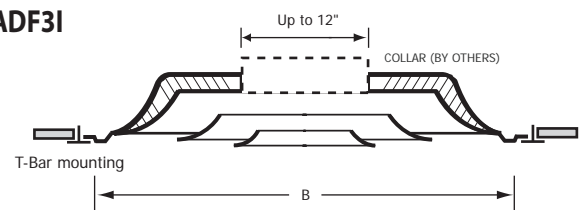
HANDY FEATURES

- One standard model suits both T-Bar and Drywall installations using rigid ducts
- Compatible with Airvector's exclusive Easy Install PF frame
- Core is easily removable without tools to facilitate access to duct.

ADF3 / ADF3D



ADF3I



DATA SHEET

ENGINEERING PERFORMANCE DATA

MODELS ADF3, ADF3D & ADF3I

3 CONE



AIRVECTOR®

12" x 12" face

SIZE (inches)	Neck Velocity (fpm)	400	500	600	700	800	1000	1200	1400	1600
		Velocity Pressure (in H ₂ O)	.010	.016	.022	.031	.041	.062	.090	.122
6	CFM	78	98	118	137	157	196	235	274	313
	Total Pressure	.02	.03	.04	.06	.07	.10	.16	.22	.29
	NC	< 20	< 20	< 20	< 20	< 20	25	29	34	40
	Throw (ft)	2-3-6	3-4-7	4-5-9	4-5-10	5-6-11	6-8-12	7-9-13	8-10-15	9-11-16
8	CFM	140	175	209	244	279	349	419	489	559
	Total Pressure	.03	.04	.06	.07	.09	.14	.20	.28	.38
	NC	< 20	< 20	< 20	< 20	< 20	29	35	41	45
	Throw (ft)	2-4-7	3-5-9	4-7-10	5-8-11	6-9-12	7-10-14	8-12-17	10-12-18	11-14-20

24" x 24" face

SIZE (inches)	Neck Velocity (fpm)	400	500	600	700	800	1000	1200	1400	1600
		Velocity Pressure (in H ₂ O)	.010	.016	.022	.031	.041	.062	.090	.122
6	CFM	78	98	118	137	157	196	235	274	313
	Total Pressure	.02	.03	.04	.05	.07	.10	.14	.19	.24
	NC	< 20	< 20	< 20	< 20	< 20	22	28	32	36
	Throw (ft)	1-2-4	1-3-4	2-3-5	2-3-6	3-4-7	4-6-8	5-7-10	6-9-11	7-9-12
8	CFM	140	175	209	244	279	349	419	489	559
	Total Pressure	.02	.03	.04	.05	.08	.10	.15	.20	.25
	NC	< 20	< 20	< 20	< 20	< 20	26	31	36	41
	Throw (ft)	2-3-5	2-3-7	3-4-8	3-5-8	4-6-9	5-7-11	6-9-13	7-10-14	8-11-17
10	CFM	218	273	327	382	436	545	654	763	872
	Total Pressure	.02	.03	.04	.05	.08	.12	.17	.24	.30
	NC	< 20	< 20	< 20	< 20	22	29	34	38	43
	Throw (ft)	3-4-6	4-5-8	4-6-10	5-7-12	6-8-14	7-9-15	8-11-16	9-12-17	10-13-19
12	CFM	314	393	471	550	628	785	941	1099	1246
	Total Pressure	.02	.04	.05	.07	.09	.14	.20	.27	.36
	NC	< 20	< 20	< 20	20	23	39	36	41	46
	Throw (ft)	4-5-9	5-6-10	6-7-11	6-8-13	7-9-15	8-11-18	10-13-21	12-16-22	13-18-21
14	CFM	492	615	738	861	984	1230	1476	1722	1968
	Total Pressure	.03	.04	.06	.08	.10	.18	.23	.30	.40
	NC	< 20	< 20	< 20	21	25	33	38	43	48
	Throw (ft)	4-6-10	5-6-11	6-8-14	7-10-16	8-11-18	10-14-20	12-16-22	14-19-24	15-20-26

NC Value based on 10 db room attenuation.

Throw Values are based on isothermal air and terminal velocities of 150 fpm, 100 fpm & 75 fpm respectively.

Total Pressure the sum of static pressure plus velocity pressure and is given in inches w.g.

HOW TO ORDER ADF3 & ADF4 SERIES

ADF3-R4-W3 2408 /W

MODEL SERIES

- 3 Cone Alum Fixed **ADF3**
- 3 Cone Alum Fixed, ... 2" Neck **ADF3D**
- 4 Cone Alum Fixed **ADF4**
- 4 Cone Alum Fixed, ... 2" Neck **ADF4D**

FINISH (OPTIONAL)
Default is White (/W)
See chart for more

NECK DIAMETER
In Inches
06-08-10-12-14"

INSULATION (OPTIONAL)
Default is uninsulated

- R4.2 Taped Insulation **-R4**
- R6 Taped Insulation **-R6**

FACE DIMENSIONS
12" x 12" **12**
24" x 24" **24**

DIRECTION (OPTIONAL)
Default is 4 Way

- 1 Way **-W1**
- 2 Way Corner **-WC**
- 2 Way Opposed **-WO**
- 3 Way **-W3**

HOW TO ORDER ADF3I & ADF4I

ADF3I /W

MODEL SERIES

- 3 Cone Alum **ADF3I**
- 4 Cone Alum **ADF4I**

FINISH (OPTIONAL)
Default is White (/W)
See chart for more

DRUM LOUVERS



Rev. 1

HIGH-CAPACITY AIR DISTRIBUTION WITH DIRECTIONAL CONTROL

MODELS **ADL10 / ADL17 / ADL18**

Surface Mount (Wall or Duct Face)

MODELS **ADLD10 / ADLD17 / ADLD18**

Round Duct Mount (Curved Frame for Spiral Ducts)

The Airvector® **ADL** and **ADLD** Drum Louver series are engineered to deliver high-capacity supply airflow with long throw distances and precise directional control. Ideal for large open spaces such as shopping malls, warehouses, stadiums, exhibition halls, and industrial facilities, they feature a rotatable cylindrical drum and adjustable vanes for full control over vertical and horizontal air patterns.

Available in both flat-frame (**ADL**) and curved-frame (**ADLD**) configurations, the series is designed to integrate seamlessly with flat surfaces or spiral ductwork.

PRODUCT VARIANTS

Surface Mounting

ADL10 - Standard drum louver, without damper.

ADL17 - With rear steel opposed blade damper for volume control

ADL18 - With integrated air scoop for enhanced directional throw

Spiral-Duct Mounting

ADLD10 - Standard drum louver, without damper.

ADLD17 - With rear steel opposed blade damper for volume control

ADLD18 - With integrated air scoop for enhanced directional throw

FEATURES

- **Adjustable Airflow Pattern** – Drum rotates up to 60° vertically; internal vanes adjust horizontally for precise spread control
- **High Throw Performance** – Ideal for spot cooling/heating in large-volume areas
- **Durable Construction** – Made from corrosion-resistant extruded aluminum
- **Low Air Leakage** – Gasket or felt seals minimize air loss and prevent drum drift

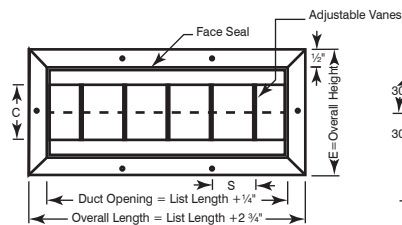


ADL10

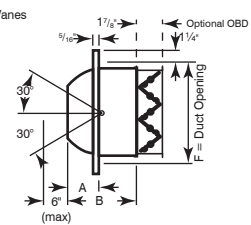


ADLD10

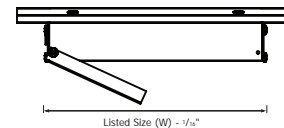
ADL



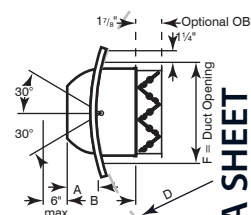
ADL17



ADL18 / ADLD18



ADLD17



DATA SHEET

Drum Louver Standard Blades ADL10 & ADLD10

Size	Duct Velocity (fpm) Velocity Pressure	300 0.006	400 0.010	500 0.016	600 0.022	700 0.031	800 0.040	900 0.050	1000 0.062
12 x 4	Ps	0.03	0.06	0.10	0.14	0.19	0.26	0.32	0.40
	CFM	100	125	166	200	233	266	300	333
	NC	-	-	-	15	19	31	37	41
	Throw	10-13-20	13-16-23	15-18-26	16-19-29	18-21-31	19-22-33	20-23-36	21-25-38
18 x 4	Ps	0.03	0.05	0.07	0.10	0.15	0.20	0.25	0.31
	CFM	150	200	250	300	350	400	450	500
	NC	-	-	-	19	26	33	37	43
	Throw	14-16-23	16-19-27	18-21-31	19-23-34	21-25-36	22-27-39	24-29-41	25-30-43
24 x 4	Ps	0.03	0.05	0.07	0.11	0.15	0.20	0.25	0.30
	CFM	200	266	333	400	466	535	600	665
	NC	-	-	10	20	27	35	38	44
	Throw	16-19-27	18-22-32	20-24-26	23-27-39	24-29-42	27-31-45	28-33-49	29-35-51
30 x 4	Ps	0.03	0.05	0.07	0.11	0.15	0.20	0.25	0.32
	CFM	250	333	415	500	583	665	750	830
	NC	-	-	12	22	28	34	39	46
	Throw	18-21-31	20-24-35	23-28-40	25-30-44	28-33-47	29-35-51	31-37-54	32-39-56
36 x 4	Ps	0.03	0.05	0.07	0.10	0.15	0.20	0.25	0.31
	CFM	300	400	500	600	700	800	900	1000
	NC	-	-	14	23	30	37	41	47
	Throw	19-23-33	22-27-38	25-30-43	27-33-48	29-35-51	31-38-55	33-40-58	35-42-62
42 x 4	Ps	0.02	0.05	0.07	0.11	0.15	0.20	0.25	0.31
	CFM	350	465	583	700	815	933	1050	1160
	NC	-	-	14	25	32	38	42	49
	Throw	21-25-36	24-28-41	26-32-47	29-35-51	32-38-58	34-41-60	36-43-64	38-46-67
48 x 4	Ps	0.03	0.05	0.08	0.11	0.15	0.20	0.25	0.31
	CFM	400	533	665	800	933	1065	1200	1330
	NC	-	-	15	25	31	38	42	50
	Throw	22-27-39	26-31-45	28-35-50	32-39-55	34-42-60	36-44-64	38-47-66	40-50-71

SYMBOLS Ps Static Pressure in inches of water
 NC Noise Criteria based on 10 db room absorption
 Throw Vertical distances in feet to a terminal velocity of 150, 100 and 50 FPM
 Velocity Pressure in water gauge

Throws shown are based on a 15° upward deflection. For 0° deflection, multiply by 1.2; for 30° deflection, multiply by 0.8.

Airvector supply grilles are fully compatible with variable air volume (VAV) systems and maintain excellent performance under varying airflow conditions.

Data based on test results according to ASHRAE Standard 70-2006.
 Performance of Air Outlets and Inlets.

CORRECTION FACTORS

	Drums Angle	
	0°	30°
NC	-4	+4
Throw	1.2	0.8
Ps	0.8	1.43

Drum Louver Standard Blades ADL10 & ADLD10

Size	Duct Velocity (fpm) Velocity Pressure	300 0.006	400 0.010	500 0.016	600 0.022	700 0.031	800 0.040	900 0.050	1000 0.062
12 x 6	Ps	0.05	0.08	0.13	0.18	0.25	0.32	0.41	0.51
	CFM	169	226	282	339	395	451	508	564
	NC	10	10	18	24	30	34	42	44
	Throw	5-8-18	10-14-25	12-17-29	15-21-33	17-23-35	19-26-37	20-29-39	22-30-41
18 x 6	Ps	0.05	0.08	0.13	0.19	0.25	0.32	0.41	0.51
	CFM	250	333	416	500	584	666	749	833
	NC	-	11	19	25	31	36	40	43
	Throw	11-16-28	14-21-33	18-26-37	21-28-40	25-31-43	27-33-46	29-35-49	30-37-52
24 x 6	Ps	0.05	0.08	0.13	0.18	0.25	0.32	0.41	0.51
	CFM	331	441	551	661	771	881	991	1101
	NC	10	11	19	25	30	35	39	43
	Throw	14-20-32	18-25-37	22-30-41	25-32-44	29-35-47	30-36-49	32-39-53	34-41-56
30 x 6	Ps	0.05	0.08	0.13	0.18	0.25	0.32	0.41	0.51
	CFM	411	548	685	821	959	1095	1232	1369
	NC	<10	10	18	23	29	34	38	42
	Throw	17-26-37	23-30-42	28-34-47	30-37-52	32-39-56	34-42-60	37-45-63	38-47-67
36 x 6	Ps	0.05	0.08	0.13	0.18	0.25	0.32	0.41	0.51
	CFM	491	655	819	982	1146	1310	1473	1637
	NC	10	11	19	25	30	35	39	43
	Throw	20-29-40	25-32-44	29-35-49	32-39-54	35-42-59	37-45-63	40-48-66	41-50-70
42 x 6	Ps	0.05	0.08	0.13	0.18	0.25	0.32	0.41	0.51
	CFM	572	762	953	1143	1334	1524	1715	1905
	NC	10	12	20	26	31	36	40	44
	Throw	22-31-42	27-34-46	31-37-51	35-42-57	37-44-61	40-48-66	43-51-69	44-53-73
48 x 6	Ps	0.05	0.08	0.13	0.18	0.25	0.32	0.41	0.51
	CFM	652	870	1087	1304	1521	1739	1956	2174
	NC	10	14	21	28	33	38	42	46
	Throw	25-34-45	30-37-49	34-40-54	38-45-60	40-47-64	42-50-68	45-53-71	47-56-76

SYMBOLS
 Ps Static Pressure in inches of water
 NC Noise Criteria based on 10 db room absorption
 Throw Vertical distances in feet to a terminal velocity of 150, 100 and 50 FPM
 Velocity Pressure in water gauge

Throws shown are based on a 15° upward deflection. For 0° deflection, multiply by 1.2; for 30° deflection, multiply by 0.8.

Airvector supply grilles are fully compatible with variable air volume (VAV) systems and maintain excellent performance under varying airflow conditions.

Data based on test results according to ASHRAE Standard 70-2006.
Performance of Air Outlets and Inlets.

CORRECTION FACTORS

	Drums Angle	
	0°	30°
NC	-4	+4
Throw	1.2	0.8
Ps	0.8	1.43

Drum Louver Standard Blades ADL10 & ADLD10

Size	Duct Velocity (fpm) Velocity Pressure	300 0.006	400 0.010	500 0.016	600 0.022	700 0.031	800 0.040	900 0.050	1000 0.062
12 x 8	Ps	0.03	0.06	0.10	0.14	0.20	0.26	0.32	0.40
	CFM	200	265	333	400	465	533	600	665
	NC	-	-	-	19	27	33	40	45
	Throw	12-19-28	16-22-32	19-24-35	22-26-39	23-28-42	25-30-45	28-32-49	29-35-50
18 x 8	Ps	0.04	0.06	0.10	0.15	0.20	0.26	0.32	0.40
	CFM	300	400	500	600	700	800	900	1000
	NC	-	-	-	19	27	34	37	43
	Throw	18-23-33	21-26-38	24-29-42	27-32-47	29-34-50	31-37-54	33-39-58	34-41-60
24 x 8	Ps	0.04	0.06	0.10	0.14	0.20	0.26	0.33	0.40
	CFM	400	533	665	800	933	1065	1200	1330
	NC	-	-	13	22	30	37	43	48
	Throw	21-26-39	25-30-44	27-34-49	31-37-54	33-40-59	35-43-63	38-46-66	40-49-71
30 x 8	Ps	0.04	0.06	0.10	0.14	0.20	0.26	0.33	0.40
	CFM	500	665	833	1000	1165	1333	1500	1665
	NC	-	-	15	25	32	39	44	49
	Throw	24-29-43	28-34-50	31-38-55	33-42-60	36-46-66	38-49-70	41-52-74	43-55-79
36 x 8	Ps	0.03	0.06	0.11	0.15	0.22	0.28	0.35	0.44
	CFM	600	800	1000	1200	1400	1600	1800	2000
	NC	-	-	17	26	33	40	45	50
	Throw	27-32-47	31-36-54	35-41-60	38-45-66	41-49-71	43-52-76	46-55-81	48-59-85
42 x 8	Ps	0.04	0.07	0.11	0.15	0.22	0.28	0.35	0.44
	CFM	700	933	1165	1400	1633	1865	2100	2335
	NC	-	-	16	27	34	41	46	51
	Throw	28-34-50	32-38-58	36-44-64	39-48-70	43-52-76	46-56-82	48-59-87	50-62-92
48 x 8	Ps	0.04	0.07	0.10	0.15	0.22	0.28	0.35	0.44
	CFM	400	533	665	800	933	1065	1200	1330
	NC	-	-	17	26	35	42	47	51
	Throw	3-37-55	35-43-63	40-47-70	43-50-77	47-56-84	50-60-90	53-64-95	56-68-100

SYMBOLS Ps Static Pressure in inches of water
 NC Noise Criteria based on 10 db room absorption
 Throw Vertical distances in feet to a terminal velocity of 150, 100 and 50 FPM
 Velocity Pressure in water gauge

Throws shown are based on a 15° upward deflection. For 0° deflection, multiply by 1.2; for 30° deflection, multiply by 0.8.

Airvector supply grilles are fully compatible with variable air volume (VAV) systems and maintain excellent performance under varying airflow conditions.

Data based on test results according to ASHRAE Standard 70-2006.
 Performance of Air Outlets and Inlets.

CORRECTION FACTORS

	Drums Angle	
	0°	30°
NC	-4	+4
Throw	1.2	0.8
Ps	0.8	1.43

Drum Louver Standard Blades ADL10 & ADLD10

Size	Duct Velocity (fpm) Velocity Pressure	300 0.01	400 0.01	500 0.02	600 0.02	700 0.03	800 0.04	900 0.05	1000 0.06
15 x 10	Ps	0.03	0.05	0.09	0.13	0.17	0.22	0.28	0.34
	CFM	324	438	547	656	765	875	984	1094
	NC	10	13	20	26	31	36	40	44
	Throw	14-20-28	19-23-33	21-25-37	23-28-40	25-31-44	27-33-46	28-34-49	30-37-52
24 x 10	Ps	0.03	0.05	0.09	0.12	0.17	0.22	0.28	0.34
	CFM	523	697	871	1045	1219	1393	1568	1742
	NC	10	13	20	26	32	37	41	45
	Throw	20-29-41	27-33-47	30-37-53	33-41-57	36-44-62	39-47-67	41-49-70	43-53-74
30 x 10	Ps	0.03	0.05	0.09	0.12	0.17	0.22	0.28	0.34
	CFM	650	867	1084	1300	1516	1733	1950	2167
	NC	10	14	21	27	34	39	43	47
	Throw	23-32-45	30-37-52	33-41-58	37-45-63	39-49-69	43-52-73	45-55-73	47-58-82
36 x 10	Ps	0.03	0.05	0.09	0.11	0.17	0.22	0.28	0.34
	CFM	777	1037	1296	1554	1814	2073	2332	2591
	NC	10	15	22	28	33	38	42	46
	Throw	27-35-49	32-40-57	37-45-63	40-49-70	43-53-75	47-57-80	49-60-85	52-63-90
42 x 10	Ps	0.03	0.05	0.09	0.11	0.17	0.22	0.28	0.34
	CFM	904	1207	1508	1809	2111	2412	2714	3016
	NC	10	15	22	28	34	39	43	47
	Throw	30-38-53	35-43-62	40-49-69	43-53-76	47-58-81	51-62-87	53-65-92	56-69-98
48 x 10	Ps	0.03	0.05	0.09	0.11	0.17	0.22	0.28	0.34
	CFM	1032	1376	1720	2064	2408	2752	3096	3440
	NC	10	16	23	29	35	40	44	48
	Throw	33-41-58	38-47-66	43-53-74	47-58-82	51-62-88	51-62-88	58-70-100	61-74-105
72 x 10	Ps	0.03	0.05	0.09	0.11	0.17	0.22	0.28	0.34
	CFM	1484	1967	2472	2976	3452	3949	4456	4949
	NC	10	18	25	31	36	41	45	49
	Throw	41-50-71	48-58-82	53-65-91	58-71-101	63-76-109	67-82-116	71-86-123	75-91-129

SYMBOLS Ps Static Pressure in inches of water
 NC Noise Criteria based on 10 db room absorption
 Throw Vertical distances in feet to a terminal velocity of 150, 100 and 50 FPM
 Velocity Pressure in water gauge

Throws shown are based on a 15° upward deflection. For 0° deflection, multiply by 1.2; for 30° deflection, multiply by 0.8.

Airvector supply grilles are fully compatible with variable air volume (VAV) systems and maintain excellent performance under varying airflow conditions.

Data based on test results according to ASHRAE Standard 70-2006.
 Performance of Air Outlets and Inlets.

CORRECTION FACTORS

	Drums Angle	
	0°	30°
NC	-4	+4
Throw	1.2	0.8
Ps	0.8	1.43

Drum Louver Standard Blades ADL10 & ADLD10

Size	Duct Velocity (fpm) Velocity Pressure	300 0.01	400 0.01	500 0.02	600 0.02	700 0.03	800 0.04	900 0.05	1000 0.06
15 x 12	Ps	0.03	0.05	0.08	0.11	0.16	0.20	0.26	0.32
	CFM	397	529	662	793	926	1057	1190	1323
	NC	10	13	21	27	32	37	40	44
	Throw	17-22-31	20-26-36	23-29-40	26-31-44	27-34-47	27-34-47	29-36-50	31-38-53
24 x 12	Ps	0.03	0.05	0.08	0.11	0.16	0.20	0.26	0.32
	CFM	625	833	1042	1250	1459	1667	1876	2084
	NC	8	10	19	27	32	37	42	46
	Throw	24-31-44	29-37-52	33-41-57	37-44-63	39-48-68	42-52-72	44-54-77	46-56-81
30 x 12	Ps	0.03	0.05	0.08	0.11	0.16	0.20	0.26	0.32
	CFM	778	1037	1296	1555	1815	2074	2333	2592
	NC	5	7	19	27	33	38	43	47
	Throw	28-35-50	33-41-58	37-46-64	41-50-70	44-54-76	47-58-81	50-61-86	52-64-91
36 x 12	Ps	0.03	0.05	0.08	0.11	0.16	0.20	0.26	0.32
	CFM	930	1240	1550	1860	2170	2480	2789	3100
	NC	2	3	18	26	33	39	43	48
	Throw	31-39-55	37-44-63	41-50-71	44-55-77	48-59-83	52-63-89	55-67-94	57-71-100
42 x 12	Ps	0.03	0.05	0.08	0.11	0.16	0.20	0.26	0.32
	CFM	1082	1443	1804	2165	2525	2886	3246	3607
	NC	-	-	17	26	33	39	44	49
	Throw	34-42-59	40-48-68	44-54-77	48-59-84	52-63-90	56-68-96	56-72-102	62-77-108
48 x 12	Ps	0.03	0.05	0.08	0.11	0.16	0.20	0.26	0.32
	CFM	1234	1646	2058	2469	2881	3293	3704	4115
	NC	-	-	18	27	34	40	45	50
	Throw	36-44-63	42-51-73	47-58-81	51-63-89	55-67-96	60-73-102	63-77-109	66-81-115
72 x 12	Ps	0.03	0.05	0.08	0.11	0.16	0.20	0.26	0.32
	CFM	1844	2459	3074	3688	4302	4917	5532	6146
	NC	-	-	20	28	35	41	47	52
	Throw	45-55-77	52-63-89	58-70-100	63-77-110	68-83-119	73-89-127	77-94-134	81-96-141

SYMBOLS Ps Static Pressure in inches of water
 NC Noise Criteria based on 10 db room absorption
 Throw Vertical distances in feet to a terminal velocity of 150, 100 and 50 FPM
 Velocity Pressure in water gauge

Throws shown are based on a 15° upward deflection. For 0° deflection, multiply by 1.2; for 30° deflection, multiply by 0.8.

Airvector supply grilles are fully compatible with variable air volume (VAV) systems and maintain excellent performance under varying airflow conditions.

Data based on test results according to ASHRAE Standard 70-2006.
 Performance of Air Outlets and Inlets.

CORRECTION FACTORS

	Drums Angle	
	0°	30°
NC	-4	+4
Throw	1.2	0.8
Ps	0.8	1.43

Drum Louver Standard Blades ADL10 & ADLD10

Size	Duct Velocity (fpm) Velocity Pressure	300	400	500	600	700	800	900	1000
		0.01	0.01	0.02	0.02	0.03	0.04	0.05	0.06
15 x 15	Ps	0.02	0.04	0.07	0.10	0.13	0.17	0.22	0.27
	CFM	494	660	824	989	1154	1318	1483	1648
	NC	-	-	15	23	30	36	41	46
	Throw	19-28-40	25-33-46	30-37-51	33-41-57	35-44-61	38-46-65	40-49-69	42-52-73
24 x 15	Ps	0.02	0.04	0.07	0.10	0.13	0.17	0.22	0.27
	CFM	779	1039	1299	1559	1818	2077	2337	2597
	NC	-	-	15	24	31	37	43	47
	Throw	25-34-49	31-40-55	36-47-60	38-47-66	41-50-71	45-54-77	48-59-82	51-62-86
30 x 15	Ps	0.02	0.04	0.07	0.10	0.13	0.17	0.22	0.27
	CFM	969	1292	1615	1938	2261	2584	2907	3230
	NC	-	-	16	25	32	38	44	48
	Throw	29-38-54	35-44-62	40-46-65	42-51-72	45-55-86	49-60-84	54-66-93	57-70-98
36 x 15	Ps	0.02	0.04	0.07	0.10	0.13	0.17	0.22	0.27
	CFM	1159	1545	1932	2318	2704	3090	3476	3863
	NC	-	-	17	26	33	39	45	49
	Throw	33-42-59	39-49-68	44-50-71	46-56-79	49-60-85	49-60-85	59-72-103	62-78-108
42 x 15	Ps	0.02	0.04	0.07	0.10	0.13	0.17	0.22	0.27
	CFM	1349	1798	2248	2698	3147	3596	4046	4495
	NC	-	-	18	27	34	40	46	50
	Throw	37-46-64	43-53-74	49-54-74	49-60-85	53-65-93	58-71-100	64-80-113	68-82-118
48 x 15	Ps	0.02	0.04	0.07	0.10	0.13	0.17	0.22	0.27
	CFM	1539	2052	2565	3077	3590	4102	4615	5128
	NC	-	-	19	28	35	41	47	51
	Throw	41-50-70	47-58-81	52-58-79	53-65-91	57-71-98	63-76-107	70-84-122	74-89-126
72 x 15	Ps	0.02	0.04	0.07	0.10	0.13	0.17	0.22	0.27
	CFM	2307	3075	3844	4613	5382	6151	6920	7689
	NC	-	-	21	29	36	42	48	53
	Throw	50-61-86	58-71-100	64-79-112	71-86-122	76-94-132	81-100-141	86-106-151	92-112-158

SYMBOLS
 Ps Static Pressure in inches of water
 NC Noise Criteria based on 10 db room absorption
 Throw Vertical distances in feet to a terminal velocity of 150, 100 and 50 FPM
 Velocity Pressure in water gauge

Throws shown are based on a 15° upward deflection. For 0° deflection, multiply by 1.2; for 30° deflection, multiply by 0.8.

Airvector supply grilles are fully compatible with variable air volume (VAV) systems and maintain excellent performance under varying airflow conditions.

Data based on test results according to ASHRAE Standard 70-2006.
Performance of Air Outlets and Inlets.

CORRECTION FACTORS

	Drums Angle	
	0°	30°
NC	-4	+4
Throw	1.2	0.8
Ps	0.8	1.43

LINEAR BAR GRILLES



ALB SERIES Architectural Linear Bar Grilles

For Ceiling, Sidewall, Sill, and Floor Installation

Series ALB (Architectural Linear Bar) Grilles are designed for installation in the sidewall, sill, floor, and ceiling, and are recommended for supplying heated, ventilated, or cooled air, and for returning or exhausting room air. Their reliable performance assures confident use of cooling temperature differentials up to 25°F at predicted low air motion of 35 fpm in the zone of occupancy. Series ALB Grilles perform efficiently with air loadings of 1 to 2¹/₂ CFM per sq.ft. and a sound level range of NC 25 to 35.

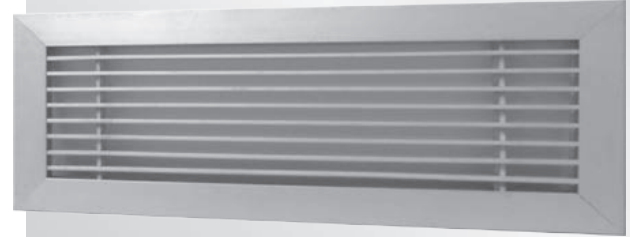
When installed in the sidewall near the ceiling, Series ALB Grilles provide a horizontal pattern above the occupied zone. Core deflections of 15° or 30° direct the air path upward to overcome the drop effect resulting from cool primary air. Use of the deflected cores also improves sight-tightness of the grille face.

When installed in the top of a sill or enclosure, Series ALB Grilles provide a vertical up pattern which is effective in overcoming uncomfortable cold downdrafts and offsetting the radiant effect of glass surfaces. Core deflections of 0°, 15°, and 30° directed toward the glass surface provide upward airflow to the ceiling toward the interior zone.

When installed in the ceiling, Series ALB Grilles provide a vertical downward air pattern which is effective in projection heating and cooling the building perimeter from ceiling heights above 12-15 ft. Application of downflow primary air should be limited in volume to insure against excessive drafts at the end of the throw. Core deflections of 0°, 15°, and 30° direct the air path angularly downward as required.

For floor installations, grilles are specially reinforced. Maximum listed width is 6" for constant traffic areas and areas where heavy loads such as copiers or other equipment may be rolled across grilles. In no case should equipment be "parked" on grilles. For occasional traffic areas, maximum listed width is 8". Maximum listed length is 60".

Series ALB Grilles are fabricated of high-quality aluminum extrusions. Components are mechanically interlocked for a blemish-free appearance. Key-ways and splice plates facilitate hair-line butting of 5 ft. sections to form continuous lengths. Opposable Blade Volume dampers are integrally fastened to Series ALB Grilles. Adjustable Air Equalizing Grids provide spread pattern deflection to shorten the throw. Friction spring fasteners on margins hold grilles to duct collar in sill installations. Mitered corner sections are furnished in one piece.



ALB10

FEATURES

- Six bar styles including Pencil Proof
- 0°, 15°, 30° bar deflections
- Friction margin spring fasteners to hold grilles to duct collars for sill installations
- Extruded Aluminum construction: Mechanical assembly
- Butts available in continuous lengths with key-way splices. Factory cut or field cut lengths for precise installation
- White color default. Available in Black colour, Silver aluminium colour, Brushed & lacquered finish, Mill finish, Primer, Satin Anodized finish. Custom colors and finishes available on request.

Accessories/Options

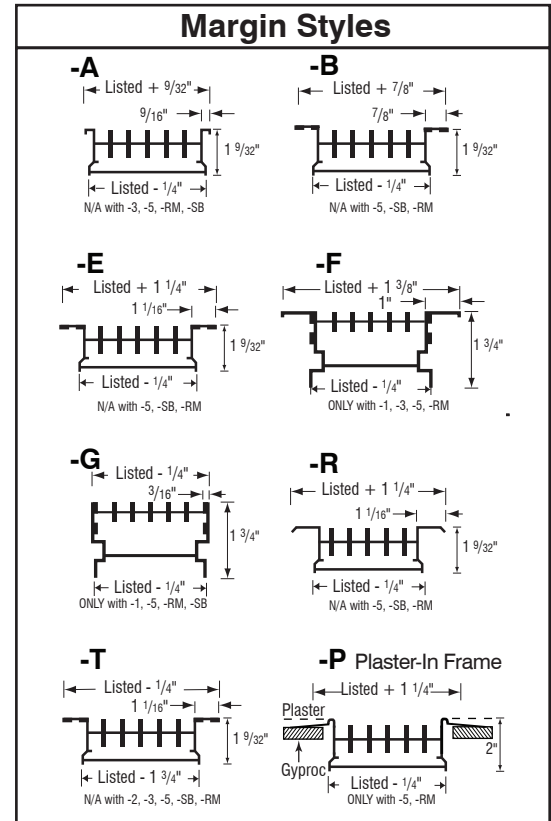
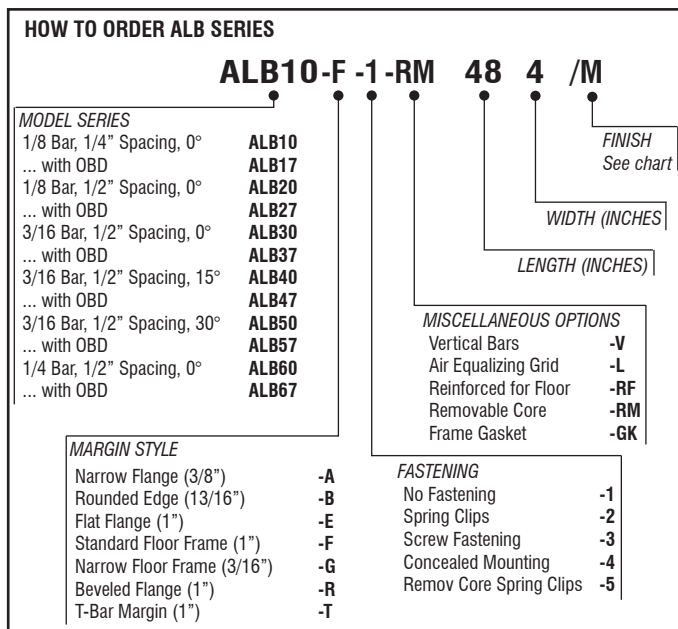
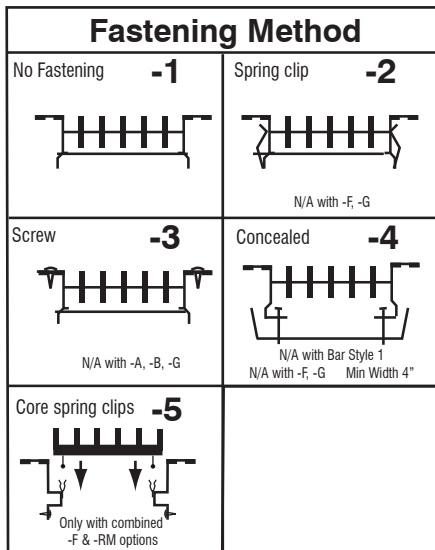
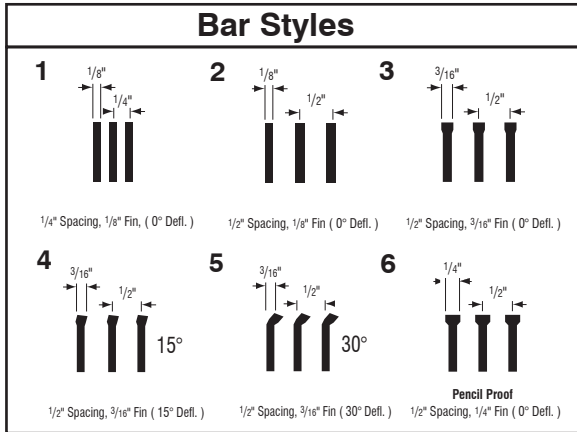
- Opposable Blade Damper
- Air Equalizing Grid (min. width 4")
- Removable core
- Reinforced floor application (max. width 8")
- Mitered corner sections furnished as one piece



Mitered Corner

ARCHITECTURAL STYLES

ALB SERIES



- L** Air Equalizing Grid (Minimum 4" wide)
- RF** Reinforced Floor Application (Up to 8" wide for occasional traffic)
- RM** Removable Core Application Only w/ -F, -G
- GK** Frame Gasket

LISTED SIZES AVAILABLE

Min. (no OBD) LxW	Min. with OBD LxW	Max. LxW
6" x 1 1/2"	6" x 3"	60" x 16"

1/8 inch fractional increments in length
 1/2 inch fractional increments in width (no OBD)
 1 inch increments in width with OBD

Sizes longer than maximum will be furnished in multiple sections for field butting

All dimensions in inches.
 6" maximum width for constant traffic. 8" maximum width for occasional traffic.
 Series ALB products include a 1/32" tolerance for thermal expansion based on a +40°F temperature differential.
 For every +20°F differential above +40°F, reduce required listed length by 1/64" per 5 feet of length.

ENGINEERING PERFORMANCE DATA

ALB SERIES



NOTES:

- a. Table 1 based on 4 ft. grille length. For longer lengths, correct throw and NC per Table 2.
- b. When using continuous grille lengths with alternate active and inactive sections, a reduction in throw can be obtained by omitting the factors contained in table 2.
- c. Bar style 1: Increase Table 1 NC + 5 NC.
- d. Supply air temperature effect on horizontal throw is shown in table 3. Vertical down-throw at varying supply temperatures is shown in Table 4.

- e. When spreading the air path with horizontal deflection of 22° per side in grille lengths up to 4 ft.:

- Multiply Table 1 Throw x .75
- Increase Table 1 NC x 5 NC
- Multiply Table 1 P_S x 1.20
- Multiply Table 5 A_K x .90

- f. Terminal velocities (V_T) at the minimum and maximum Throw (T) values are rated at 125 FPM and 75 FPM respectively with corresponding room velocities (V_R) of 50 fpm and 35 FPM.

TABLE 2 CONTINUOUS GRILLE LENGTH FACTORS

Modify Table 1 by listed values for grille lengths above 4ft.			
Grille Length	Throw (T)		NC
	Sidewall Min.-Max.	Sill Min.-Max.	
4' - 6'	No Change		+ 0
7' - 20'	T x 1.10		+ 5
21' - 100'	T x 1.15		+ 10

TABLE 3 SUPPLY AIR TEMPERATURE FACTORS

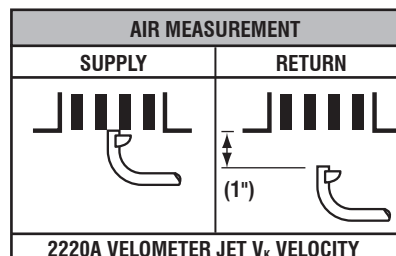
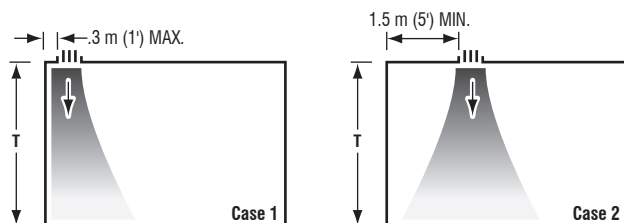
Multiply Throw in Table 1 (or factor in Table 2 if used) by listed value.			
	@ -29°C ΔT	@ -18°C ΔT	@ -4°C ΔT
Sidewall	@ -20°F ΔT T x 1.10	@ 0°F ΔT T x 1.11	@ +25°F ΔT T x 1.12
Sill			

TABLE 4 VERTICAL DOWN-THROW and Supply Air Temperature Supply Factors

Multiply Throw-Sidewall in Table 1 (or factor in Table 2 if used) by listed value.			
	@ -29°C ΔT	@ -18°F ΔT	@ -4°C ΔT
	@ -20°F ΔT	@ 0°F ΔT	@ +25°F ΔT
	Cooling	Ventilating	Heating
Case 1	T x 1.10	T x .90	T x .60
Case 2	T x .70	T x .60	T x .40

TABLE 5 SUPPLY GRILLES AREAS Per Ft. of Length

Listed Width in inches																	
A _N	1.5"	2"	2.5"	3"	4"	5"	6"	8"	10"	12"	14"	16"	18"	20"	24"	30"	36"
	.13	.17	.21	.25	.33	.42	.50	.67	.84	1.0	1.2	1.3	1.5	1.7	2.0	2.5	3.0
A _K	.04	.06	.09	.11	.16	.20	.25	.35	.45	.55	.68	.79	.90	1.0	1.3	1.6	2.1
A _K	.03	.05	.08	.09	.14	.17	.21	.30	.38	.47	.58	.67	.77	.85	1.1	1.4	1.8



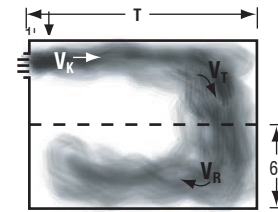
ENGINEERING PERFORMANCE DATA

ALB SERIES

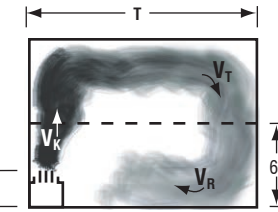


TABLE 1 SUPPLY AIR

CFM per Foot	Listed Width in Inches	Min. P _s in H ₂ O		Outlet Velocity (V _k) FPM		Throw (T) in Feet		Minimum Ceiling Height in Feet		NC
		Bar Style		Bar Style		Sidewall	Sill	@-18°F ΔT	@-25°F ΔT	
		2 & 3 & 4 & 5	1 & 6	2 & 3 & 4 & 5	1 & 6	Min.-Max.	Min.-Max.			
20	1 1/2	.01	.01	500	575	6-9	1-2	8	9	<20
30	1 1/2	.03	.04	750	865	7-10	2-3	9	10	25
	2	.01	.01	475	545	6-9	1-2			
40	1 1/2	.05	.07	1000	1150	9-13	3-5	9	11	30
	2	.02	.03	635	730	8-11	2-4			
	2 1/2	.01	.01	460	530	7-10	2-3			
50	1 1/2	.09	.12	1250	1440	11-16	4-9	9 1/2	11	30
	2	.03	.04	790	910	10-14	3-7			
	2 1/2	.02	.03	575	660	9-13	2-6			
	3	<.01	.01	440	505	8-12	2-5			
60	2	.05	.07	950	1090	12-18	5-11	9 1/2	12	30
	2 1/2	.02	.03	690	795	11-16	4-9			
	3	.01	.01	530	610	10-14	3-7			
	4	<.01	.01	370	425	8-12	2-5			
70	2	.06	.08	1100	1275	14-20	7-13	10	12	30
	2 1/2	.03	.04	810	935	13-19	6-12			
	3	.02	.03	660	760	11-16	4-9			
	4	<.01	.01	435	500	10-14	3-7			
80	2	.08	.10	1275	1450	16-23	9-16	10 1/2	12 1/2	30
	2 1/2	.04	.05	920	1060	15-21	8-14			
	3	.03	.04	700	805	13-18	6-11			
	4	.01	.01	495	570	11-16	4-9			
90	2 1/2	.05	.07	1030	1185	17-24	10-17	11	13	30
	3	.04	.05	785	905	15-21	8-14			
	4	.01	.02	550	635	13-18	6-11			
	5	<.01	.01	450	520	11-16	4-9			
	2 1/2	.06	.08	1150	1325	19-27	12-20			
3	.04	.05	875	1010	16-23	9-16				
4	.02	.03	620	715	14-20	7-13				
100	5	.01	.01	500	575	12-18	5-11			20
	3	.06	.08	1050	1210	19-28	11-20	11 1/2	13	30
	4	.03	.04	745	855	17-24	9-16			
5	.02	.03	600	680	15-22	7-14				
120	6	<.01	.01	480	550	13-19	5-11			20
	3	.08	.11	1220	1410	22-32	14-24	11 1/2	14	35
	4	.04	.05	870	1000	19-28	11-20			
5	.02	.03	700	810	17-25	9-17				
140	6	.01	.01	560	645	15-22	7-14			20
	4	.05	.07	990	1140	22-32	13-23	12	15	35
	5	.03	.04	800	925	19-29	10-20			
	6	.02	.03	640	735	18-26	9-17			
8	.01	.01	460	530	15-22	6-13				
160	4	.07	.09	1110	1275	25-36	16-27	12	15	35
	5	.04	.05	900	1035	22-33	13-24			
	6	.03	.04	725	835	20-30	11-21			
	8	.02	.03	520	600	17-25	8-16			
200	4	.08	.11	1240	1425	28-41	-	12	15	40
	5	.05	.07	1000	1150	24-36	-			
	6	.04	.05	800	925	23-33	-			
	8	.02	.03	575	665	20-28	-			
250	5	.08	.11	1250	1440	30-46	-	13	15	40
	6	.05	.07	1000	1150	27-39	-			
	8	.03	.04	720	830	25-35	-			
	10	.01	.01	550	635	21-32	-			
300	6	.07	.09	1200	1375	33-48	-	13	15	40
	8	.04	.05	865	1000	29-42	-			
	10	.02	.03	665	765	25-39	-			
	12	.01	.01	545	630	23-33	-			
350	8	.05	.08	1020	1175	34-48	-	13	15	40
	10	.03	.04	780	900	29-45	-			
	12	.02	.03	640	735	26-38	-			
400	8	.08	.11	1170	1350	40-55	-	14	16	45
	10	.04	.05	890	1025	33-50	-			
	12	.03	.04	730	845	30-44	-			



SIDEWALL



SILL

Outlet Velocity (V _k) FPM												
500	600	700	800	900	1000	1200	1400	1600	1800	2000		
Total Pressure (P _t) Inches H ₂ O												
.02	.02	.03	.04	.05	.06	.09	.12	.16	.20	.25		

SYMBOLS
 V_T Terminal Velocity in fpm
 V_R Room Velocity in fpm
 V_K Outlet Velocity in fpm
 A_K Outlet area in Sq. Feet
 A_N Neck Area in Sq. Ft.
 P_S Static Pressure H₂O
 NC Re 8db Room attenuation
 T Throw in feet at X and Y
 ΔT Temperature Differential

ENGINEERING PERFORMANCE DATA

ALB SERIES



TABLE 2 RETURN AIR - CFM Per Foot of Length

Listed Width in Inches	A _K Area	Bar Style	NC 20-25 Non-Ducted		NC 25-30 Ducted		NC 30-40 Ducted	
			-02" P _S	-03" P _S	-08" P _S	-10" P _S	-15" P _S	-20" P _S
			CFM	CFM	CFM	CFM	CFM	CFM
1 1/2	.13	3 4 1	20	25	40	45	55	65
	.12	5	15	20	35	40	45	55
2	.18	3 4 1	30	40	65	70	90	100
	.17	5	25	35	55	60	75	85
2 1/2	.23	3 4 1	45	50	85	95	115	135
	.22	5	35	45	70	80	100	115
3	.27	3 4 1	55	65	105	120	145	165
	.25	5	45	55	90	100	120	140
4	.34	3 4 1	75	90	150	165	205	235
	.33	5	60	75	125	140	170	195
5	.41	3 4 1	95	120	190	215	260	305
	.39	5	80	100	160	180	220	255
6	.46	3 4 1	120	145	240	265	325	375
	.44	5	100	120	200	220	270	315

Listed Width in Inches	A _K Area	Bar Style	NC 20-25 Non-Ducted		NC 25-30 Ducted		NC 30-40 Ducted	
			-02" P _S	-03" P _S	-08" P _S	-10" P _S	-15" P _S	-20" P _S
			CFM	CFM	CFM	CFM	CFM	CFM
8	.57	3 4 1	160	200	325	360	445	515
	.54	5	135	165	270	305	370	430
10	.68	3 4 1	210	255	415	465	570	655
	.64	5	175	215	350	390	475	550
12	.76	3 4 1	255	310	510	565	695	800
	.72	5	210	260	425	475	580	670
16	.93	3 4 1	350	430	700	785	960	1100
	.86	5	285	350	570	635	780	900
20	1.1	3 4 1	445	545	885	990	1220	1410
	1.0	5	365	445	730	815	1000	1160
24	1.25	3 4 1	540	660	1080	1210	1475	1710
	1.15	5	440	540	880	985	1200	1390
30	1.45	3 4 1	670	820	1335	1495	1825	2110
	1.32	5	550	670	1090	1225	1500	1735
36	1.65	3 4 1	820	1010	1645	1835	2250	2600
	1.5	5	670	820	1335	1490	1825	2110

SYMBOLS

V_T Terminal Velocity in fpm
 V_R Room Velocity in fpm
 V_K Outlet Velocity in fpm

A_K Outlet area in Sq. Feet
 P_T Total Pressure H₂O
 P_S Static Pressure H₂O

NC Re 8db Room attenuation
 T Throw in feet at X and Y
 ΔT Temperature Differential



HOW TO SPECIFY ARCHITECTURAL LINEAR BAR GRILLES AND REGISTERS

Supply Register

Supply and mounting of linear bar register with attached opposed blade damper and 45 degree mitered corners, series **ALB**. Constructed from extruded aluminum, manufactured by Airvector.

Return Grille

Supply and mounting of linear bar grille with 45 degree mitered corners, series **ALB**. Constructed from extruded aluminum, manufactured by Airvector.

SLOT DIFFUSERS



Rev. 0

MODELS ALF10/20, ALF17/27, ALF18/28 LINEAR FLOW BAR DIFFUSER

MODEL ALF10/ALF20 - return diffuser

MODEL ALF17/ALF27 - supply with high-flow slider

MODEL ALF18/ALF28 - supply with jet-flow baffles

Airvector's **ALF** series combines sleek aesthetics with superior functionality, designed for installation in surface or lay-in T-bar ceilings, and plaster-in frame applications. Ideal for modern architectural ceiling suspension systems, the **ALF** series ensures higher air flow with 1 or 2 slots widths to accommodate different CFM requirements, noise, and pressure reduction.

Product Variants:

Linear Flow Return: Designed for higher air flow, matching ALF17/27 Airflow diffusers and ALF18/28 Jetflow diffusers. Ideal for return air applications.

Linear Flow Airflow: Fully adjustable sliding pattern controller for precise air direction. Matching ALF10/20 slot returns and ALF18/28 Jetflow diffusers available.

Linear Flow Jetflow: Enhanced air flow with jet-flow baffles, providing a unique air distribution pattern. Matching ALF10/20 slot returns and ALF17/27 Airflow diffusers available.

The **ALF** series is an excellent choice for projects requiring a combination of modern aesthetics and high-performance air distribution. With its versatile mounting options, durable construction, and efficient performance, the **ALF** series offers a comprehensive solution for various HVAC needs.



ALF1

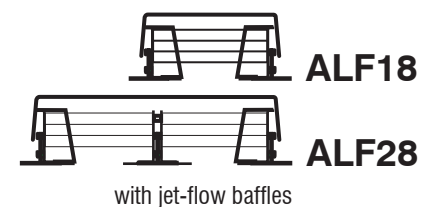
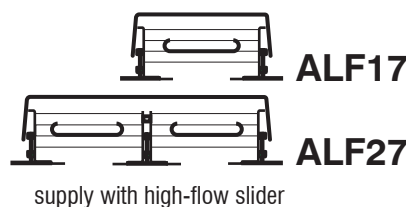
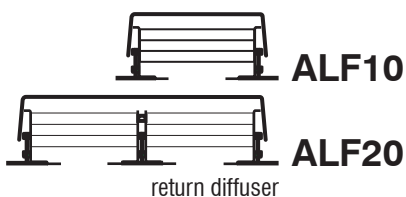


ALF2

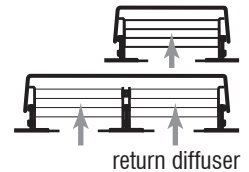
GENERAL FEATURES

- **Mounting types:** -E Surface mount, -P Plaster-In Frame or -T T-bar lay-in installations (ceiling, sidewall, or sill installations)
- **Adjustable Air Patterns:** Available with or without pattern-control dampers, high-flow sliders, or jet-flow baffles for customizable air distribution.
- **Durable Construction:** Made from extruded aluminum for long-lasting performance and a sleek appearance.
- **Custom Sizing:** Five slot sizes available (1", 1.5", 2", 2.5", 3"), with options for 1 to 2 slots wide to meet specific air volume needs.
- **Efficient Performance:** Designed for higher CFM per linear foot, ensuring effective air distribution and reduced noise levels.
- **Ideal for VAV Systems:** Compatible with Variable Air Volume (VAV) systems for efficient and flexible air management.
- **High-Quality Finish:** Powder paint coating - White, custom finish available.

DATA SHEET



Linear Flow Bar Return Diffuser ALF10/ALF20 Series



Slot width	Configuration	CFM / ft	20	40	60	80	100	120	140
		Ps	0.010	0.036	0.78	0.139	0.215	0.304	0.416
		NC	-	-	18	26	31	38	44
1.0" Slot width	1-Slot	CFM / ft	40	85	130	175	220	265	310
		Ps	0.011	0.044	0.105	0.192	0.302	0.439	0.601
		NC	-	16	28	33	38	43	47
1.5" Slot width	1-Slot	CFM / ft	30	60	90	120	150	180	210
		Ps	0.010	0.036	0.082	0.148	0.233	0.335	0.452
		NC	-	-	17	28	35	39	44
2.0" Slot width	1-Slot	CFM / ft	60	120	180	240	300	360	420
		Ps	0.012	0.042	0.094	0.169	0.266	0.385	0.528
		NC	-	18	22	29	36	41	47
2.5" Slot width	1-Slot	CFM / ft	35	75	115	155	195	235	275
		Ps	0.007	0.035	0.081	0.148	0.231	0.337	0.468
		NC	-	20	25	29	35	39	43
3" Slot width	1-Slot	CFM / ft	70	150	230	310	390	470	550
		Ps	0.010	0.036	0.094	0.168	0.266	0.391	0.543
		NC	-	23	28	31	36	41	46
2.0" Slot width	2-Slot	CFM / ft	40	95	150	205	260	315	370
		Ps	0.007	0.030	0.081	0.153	0.242	0.359	0.497
		NC	-	-	20	28	34	40	52
2.5" Slot width	2-Slot	CFM / ft	80	190	300	410	520	630	740
		Ps	0.007	0.044	0.094	0.173	0.280	0.415	0.573
		NC	-	18	24	30	36	42	55
3" Slot width	2-Slot	CFM / ft	50	115	180	245	310	375	440
		Ps	0.007	0.032	0.083	0.156	0.250	0.366	0.510
		NC	-	16	25	34	40	45	45
1.0" Slot width	2-Slot	CFM / ft	100	230	360	490	620	750	80
		Ps	0.009	0.040	0.095	0.176	0.264	0.423	0.628
		NC	-	17	24	32	38	44	48

SYMBOLS Ps Static Pressure in inches of water
NC Noise Criteria based on 10 db room absorption

LENGTH ADJUSTMENTS

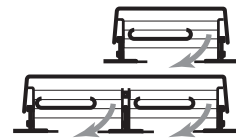
Above data obtained with 4 foot long sections. For lengths other than 4', use the adjustments in adjacent table.

Diffuser Length	2'	4'	6'	8'	10'
NC Adjustment - Return	0	+3	+5	+6	+7

- Data based on test results according to ANSI/ASHRAE 70-2006.
- Data is derived from pressurized plenum application (non ducted) disregarding plenum effects for pressure or sound.
- Plenums should be sized to ensure uniform velocity along the slot length.
- To preserve cataloged performance, duct inlet velocities should remain below 700 fpm.

Linear Flow Bar Diffusers With Continuous Slot

Adjustable high-flow slider - ALF17/ALF27 Series



Slot Width	Slots	CFM / ft	25	40	55	70	85	100	115	
		Ps	0.03	0.077	0.147	0.235	0.346	0.478	0.618	
1.0" Slot width	1-Slot	Throw	5-9-15	10-13-19	13-116-22	15-17-24	16-20-28	18-21-31	19-23-33	
		NC	-	17	27	34	40	46	51	
		2-Slot	CFM / ft	50	75	100	125	150	175	200
			Ps	0.03	0.067	0.127	0.191	0.269	0.363	0.468
	Throw		7-12-21	12-17-26	16-21-30	20-24-33	21-26-36	23-27-39	24-30-43	
	NC		-	18	27	33	39	45	50	
	1.5" Slot width	1-Slot	CFM / ft	30	45	60	75	90	105	120
			Ps	0.034	0.078	0.146	0.217	0.311	0.421	0.545
Throw			6-11-17	11-15-20	14-17-23	15-18-26	16-19-28	17-22-30	18-23-34	
NC			-	14	25	32	38	44	50	
2-Slot		CFM / ft	60	85	110	135	160	185	210	
		Ps	0.034	0.068	0.123	0.179	0.245	0.322	0.421	
		Throw	9-15-23	13-19-28	18-22-31	19-25-35	22-27-38	24-29-41	25-30-43	
		NC	-	-	20	28	32	38	42	
2.0" Slot width	1-Slot	CFM / ft	30	50	70	90	110	130	150	
		Ps	0.022	0.06	0.117	0.199	0.290	0.405	0.53	
		Throw	6-10-17	9-14-21	13-18-25	16-20-28	17-21-30	19-24-34	20-26-36	
		NC	-	12	22	31	37	42	48	
	2-Slot	CFM / ft	60	95	130	165	200	235	270	
		Ps	0.022	0.054	0.102	0.166	0.242	0.326	0.438	
		Throw	8-13-23	14-20-29	18-24-34	22-27-37	23-30-41	25-32-45	27-34-49	
		NC	-	12	23	30	37	42	48	
2.5" Slot width	1-Slot	CFM / ft	30	55	80	105	130	155	180	
		Ps	0.013	0.044	0.093	0.162	0.246	0.350	0.472	
		Throw	5-8-17	10-16-21	14-19-26	17-22-30	19-24-34	21-26-37	23-28-40	
		NC	-	12	23	31	38	44	49	
	2-Slot	CFM / ft	60	105	150	195	240	285	330	
		Ps	0.013	0.044	0.082	0.139	0.212	0.296	0.394	
		Throw	7-11-22	14-21-30	19-26-35	24-29-40	26-33-46	28-35-50	31-38-53	
		NC	-	14	25	32	39	44	49	
3.0" Slot width	1-Slot	CFM / ft	30	60	90	120	150	180	210	
		Ps	0.012	0.047	0.112	0.191	0.293	0.423	0.569	
		Throw	4-8-16	11-15-22	15-19-28	18-23-32	20-26-36	22-28-41	24-30-44	
		NC	-	-	18	28	35	40	45	
	2-Slot	CFM / ft	60	120	180	240	300	360	420	
		Ps	0.012	0.047	0.108	0.191	0.295	0.420	0.569	
		Throw	6-11-22	14-22-33	22-28-40	27-32-46	29-35-51	32-38-56	34-43-59	
		NC	-	-	22	31	38	44	48	

SYMBOLS Ps Static Pressure in inches of water
 Throw Horizontal distances in feet to a terminal velocity of 150, 100 and 50 FPM
 NC Noise Criteria based on 10 db room absorption

LENGTH MULTIPLIERS AND ADJUSTMENTS

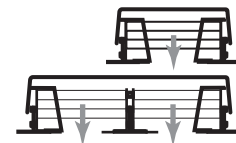
Above data obtained with 4 foot long sections. For lengths other than 4', use the multipliers and adjustments in adjacent table.

- Data based on test results according to ANSI/ASHRAE 70-2006.
- Data is derived from pressurized plenum application (non ducted) disregarding plenum effects for pressure or sound.
- Plenums should be sized to ensure uniform velocity along the slot length.
- To preserve cataloged performance, duct inlet velocities should remain below 700 fpm.

Diffuser Length	2'	4'	6'	8'	10'
Throw Multiplier	0.7	1	1.2	1.5	1.8
NC Adjustment - Supply	-2	0	+2	+3	+4

Linear Flow Bar Jet-Flow Diffusers

Jet-flow baffles - ALF18/ALF28 Series



Slot width	Configuration	CFM / ft	20	40	60	80	100	120	140
		Ps	0.007	0.029	0.065	0.117	0.182	0.260	0.355
1.0"	1-Slot	Throw	3-4-8	5-7-13	8-10-20	10-13-23	12-18-26	14-20-28	16-21-31
		NC	-	-	18	25	28	33	37
		CFM / ft	40	85	130	175	220	265	310
	2-Slot	Ps	0.007	0.033	0.077	0.140	0.220	0.319	0.432
		Throw	4-6-10	8-10-20	11-16-29	15-21-34	18-26-38	22-29-40	25-32-45
		NC	-	12	23	30	36	40	44
1.5"	1-Slot	CFM / ft	30	60	90	120	150	180	210
		Ps	0.008	0.033	0.075	0.135	0.210	0.302	0.407
		Throw	3-5-8	5-7-16	8-12-23	10-16-28	12-19-31	16-22-33	18-26-37
	2-Slot	CFM / ft	60	120	180	240	300	360	420
		Ps	0.008	0.033	0.075	0.135	0.210	0.302	0.407
		Throw	3-6-11	8-11-22	11-15-32	14-21-37	17-27-43	22-32-47	25-36-51
2.0"	1-Slot	CFM / ft	35	75	115	155	195	235	275
		Ps	0.006	0.028	0.065	0.118	0.190	0.272	0.373
		Throw	2-4-8	6-9-17	9-12-24	10-16-31	13-21-35	17-25-39	18-29-42
	2-Slot	CFM / ft	70	150	230	310	390	470	550
		Ps	0.006	0.028	0.065	0.118	0.190	0.272	0.373
		Throw	2-5-11	8-12-23	12-17-35	16-24-44	19-29-49	23-33-54	27-40-59
2.5"	1-Slot	CFM / ft	40	95	150	205	260	315	370
		Ps	0.005	0.029	0.075	0.135	0.216	0.316	0.429
		Throw	2-4-8	7-9-19	10-14-26	12-19-36	16-24-40	18-28-44	23-34-47
	2-Slot	CFM / ft	80	190	300	410	520	630	740
		Ps	0.005	0.029	0.075	0.135	0.216	0.316	0.429
		Throw	3-5-12	8-13-26	12-20-38	17-27-50	23-33-57	27-40-62	31-46-67
3.0"	1-Slot	CFM / ft	50	115	180	245	310	375	440
		Ps	0.005	0.029	0.074	0.134	0.213	0.312	0.419
		Throw	2-4-9	6-10-19	10-14-29	14-20-39	17-25-44	21-29-48	24-34-52
	2-Slot	CFM / ft	100	230	360	490	620	750	880
		Ps	0.005	0.029	0.074	0.134	0.213	0.312	0.419
		Throw	2-4-12	8-13-26	13-21-40	19-28-54	24-35-62	29-43-68	33-50-73
2-Slot	NC	-	-	22	285	35	41	45	

SYMBOLS Ps Static Pressure in inches of water
 Throw Vertical distances in feet to a terminal velocity of 150, 100 and 50 FPM
 NC Noise Criteria based on 10 db room absorption

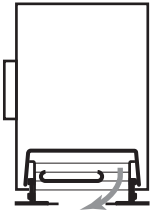
LENGTH MULTIPLIERS AND ADJUSTMENTS

Above data obtained with 4 foot long sections. For lengths other than 4', use the multipliers and adjustments in adjacent table.

- Data based on test results according to ANSI/ASHRAE 70-2006.
- Data is derived from pressurized plenum application (non ducted) disregarding plenum effects for pressure or sound.
- Plenums should be sized to ensure uniform velocity along the slot length.
- To preserve cataloged performance, duct inlet velocities should remain below 700 fpm.

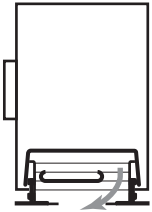
Diffuser Length	2'	4'	6'	8'	10'
Throw Multiplier	0.7	1	1.2	1.5	1.8
NC Adjustment - Supply	-2	0	+2	+3	+4

Linear Flow Bar High-Flow Diffusers Plenum with adjustable high-flow slider - ALF17 Series



1.0" Slot Width	1-Slot 6" Inlet	2 ft.	CFM / ft	25	50	75	100	125	150	175
			Total Pressure	0.008	0.032	0.072	0.129	0.201	0.296	0.394
			Ps	0.007	0.028	0.063	0.113	0.176	0.255	0.345
			NC	<10	<10	<10	20	28	36	40
		Throw	1-2-6	3-6-10	6-9-12	8-10-14	9-11-16	10-12-18	11-13-19	
		4 ft.	CFM / ft	40	80	120	160	200	240	280
			Total Pressure	0.007	0.028	0.064	0.114	0.185	0.255	0.348
			Ps	0.005	0.018	0.041	0.072	0.115	0.162	0.221
			NC	<10	<10	<10	16	24	31	37
		Throw	1-2-6	3-6-13	6-10-16	9-13-18		13-16-22		
		5 ft.	CFM / ft	50	100	150	200	250	300	350
			Total Pressure	0.009	0.034	0.077	0.137	0.216	0.308	0.419
Ps	0.005		0.018	0.041	0.072	0.115	0.162	0.221		
NC	<10		<10	<10	18	25	33	38		
Throw	1-2-7	3-7-14	7-11-18	10-14-20	12-16-23	14-18-25	16-19-27			
1.0" Slot Width	1-Slot 8" Inlet	2 ft.	CFM / ft	50	75	100	125	150	175	200
			Total Pressure	0.029	0.066	0.118	0.184	0.265	0.361	0.471
			Ps	0.028	0.063	0.113	0.176	0.253	0.345	0.450
			NC	<10	<10	19	27	34	40	44
		Throw	2-5-9	6-9-12	8-10-14	9-11-15	10-12-18	11-13-19	12-14-20	
		4 ft.	CFM / ft	70	110	150	190	230	270	310
			Total Pressure	0.016	0.040	0.075	0.120	0.176	0.243	0.320
			Ps	0.014	0.034	0.063	0.102	0.149	0.205	0.271
			NC	<10	<10	13	22	29	35	40
		Throw	2-5-10	6-9-15	8-12-18	10-14-20	12-15-21	14-17-24	15-18-25	
		5 ft.	CFM / ft	80	130	180	230	280	330	380
			Total Pressure	0.015	0.039	0.075	0.122	0.181	0.252	0.334
Ps	0.008		0.030	0.058	0.095	0.141	0.196	0.260		
NC	<10		<10	13	22	29	35	40		
Throw	2-5-12	6-9-16	9-13-19	11-15-22	14-17-24	15-18-26	16-20-28			
1.5" Slot Width	1-Slot 6" Inlet	2 ft.	CFM / ft	40	70	100	130	160	190	220
			Total Pressure	0.020	0.052	0.106	0.180	0.272	0.384	0.515
			Ps	0.014	0.044	0.090	0.152	0.231	0.326	0.437
			NC	<10	<10	16	25	33	40	46
		Throw	2-5-9	5-8-12	8-10-14	9-12-16	11-13-18	11-14-20	12-15-21	
		4 ft.	CFM / ft	80	120	160	200	240	280	320
			Total Pressure	0.024	0.056	0.099	0.155	0.223	0.304	0.397
			Ps	0.013	0.032	0.058	0.090	0.130	0.177	0.231
			NC	<10	<10	12	20	27	33	38
		Throw	3-6-13	6-10-16	9-13-18	11-14-20	13-16-22	14-17-24	15-18-26	
		5 ft.	CFM / ft	90	140	190	240	290	340	390
			Total Pressure	0.023	0.060	0.111	0.176	0.258	0.354	0.466
Ps	0.011		0.028	0.052	0.083	0.121	0.167	0.220		
NC	<10		<10	12	20	27	33	39		
Throw	3-6-13	6-10-17	9-14-20	11-16-22	14-17-24	15-19-27	16-20-28			
1.5" Slot Width	1-Slot 8" Inlet	2 ft.	CFM / ft	40	70	100	130	160	190	220
			Total Pressure	0.015	0.047	0.095	0.161	0.244	0.344	0.461
			Ps	0.014	0.044	0.090	0.152	0.231	0.326	0.437
			NC	<10	<10	14	24	31	38	44
		Throw	2-5-9	5-8-12	8-10-14	9-12-16	11-13-18	11-14-20	12-15-21	
		4 ft.	CFM / ft	80	130	180	230	280	330	380
			Total Pressure	0.018	0.047	0.090	0.146	0.217	0.301	0.400
			Ps	0.014	0.038	0.073	0.119	0.177	0.246	0.326
			NC	<10	<10	15	24	32	38	43
		Throw	3-6-13	7-10-16	10-14-19	12-16-22	14-17-24	15-18-26	16-20-28	
		5 ft.	CFM / ft	90	150	210	270	330	390	450
			Total Pressure	0.016	0.044	0.086	0.143	0.213	0.298	0.396
Ps	0.012		0.032	0.064	0.105	0.157	0.220	0.292		
NC	<10		<10	14	24	31	37	43		
Throw	3-6-13	7-11-18	10-14-20	13-17-24	15-18-26	16-20-28	18-22-31			

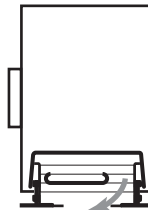
Linear Flow Bar High-Flow Diffusers Plenum with adjustable high-flow slider - ALF17 Series



2.0" Slot Width	1-Slot 8" Inlet	2 ft.	CFM / ft	50	85	120	155	190	225	260
			Total Pressure	0.015	0.045	0.089	0.149	0.223	0.313	0.418
			Ps	0.014	0.041	0.082	0.136	0.205	0.270	0.383
			NC	<10	<10	12	21	28	33	40
		Throw	2-5-10	6-9-13	8-11-16	10-13-18	11-14-20	12-15-22	13-16-23	
		4 ft.	CFM / ft	90	150	210	270	330	390	450
			Total Pressure	0.016	0.043	0.085	0.141	0.210	0.294	0.391
			Ps	0.011	0.032	0.063	0.103	0.154	0.216	0.287
			NC	<10	<10	20	29	36	42	48
		Throw	3-6-13	7-11-18	10-13-21	13-17-24	15-18-26	16-20-28	18-22-31	
		5 ft.	CFM / ft	100	165	230	295	360	425	490
			Total Pressure	0.014	0.039	0.075	0.124	0.184	0.256	0.341
Ps	0.009		0.025	0.048	0.079	0.118	0.164	0.218		
NC	<10		<10	19	28	36	42	47		
Throw	2-5-13	6-10-18	10-15-22	13-17-25	15-19-27	17-21-30	18-23-32			
2.0" Slot Width	1-Slot 12" Inlet	2 ft.	CFM / ft	50	90	130	170	210	250	290
			Total Pressure	0.014	0.047	0.098	0.167	0.254	0.361	0.485
			Ps	0.014	0.046	0.096	0.164	0.250	0.354	0.477
			NC	<10	<10	<10	13	20	27	32
		Throw	2-5-10	6-9-14	9-11-17	11-13-19	12-15-21	13-16-23	14-17-24	
		4 ft.	CFM / ft	90	165	240	315	390	465	540
			Total Pressure	0.012	0.041	0.087	0.151	0.231	0.328	0.443
			Ps	0.011	0.039	0.082	0.141	0.216	0.306	0.413
			NC	<10	<10	13	23	31	37	43
		Throw	3-6-13	8-12-18	11-16-22	15-18-26	15-20-28	18-22-31	19-24-33	
		5 ft.	CFM / ft	100	190	280	370	460	550	640
			Total Pressure	0.010	0.036	0.079	0.138	0.213	0.305	0.413
Ps	0.009		0.033	0.071	0.124	0.192	0.274	0.372		
NC	<10		<10	15	25	33	39	45		
Throw	2-5-13	8-12-19	12-17-24	16-20-28	18-22-31	19-24-34	21-26-35			
2.5" Slot Width	1-Slot 10" Inlet	2 ft.	CFM / ft	100	145	190	235	280	325	370
			Total Pressure	0.036	0.076	0.131	0.201	0.285	0.384	0.498
			Ps	0.034	0.072	0.123	0.189	0.269	0.362	0.469
			NC	<10	<10	17	26	33	39	44
		Throw	6-10-14	9-12-16	11-14-20	13-16-22	14-17-23	15-18-26	16-20-28	
		4 ft.	CFM / ft	140	220	300	380	460	540	620
			Total Pressure	0.021	0.052	0.096	0.154	0.226	0.311	0.410
			Ps	0.017	0.041	0.077	0.124	0.181	0.250	0.329
			NC	<10	<10	20	29	37	44	49
		Throw	5-9-17	10-15-25	14-18-25	16-19-28	18-22-31	19-24-33	21-25-34	
		5 ft.	CFM / ft	150	240	330	420	510	600	690
			Total Pressure	0.017	0.044	0.081	0.134	0.197	0.273	0.361
Ps	0.012		0.032	0.058	0.097	0.143	0.197	0.261		
NC	<10		<10	18	28	36	43	49		
Throw	4-9-18	10-15-22	13-18-26	17-21-29	19-23-32	20-25-35	22-27-38			
2.5" Slot Width	1-Slot 12" Inlet	2 ft.	CFM / ft	100	145	190	235	280	325	370
			Total Pressure	0.035	0.074	0.127	0.195	0.277	0.373	0.483
			Ps	0.034	0.072	0.124	0.189	0.269	0.362	0.469
			NC	<10	<10	12	21	28	34	40
		Throw	6-10-14	9-12-17	11-14-20	13-16-22	14-17-24	15-18-26	16-20-28	
		4 ft.	CFM / ft	140	225	310	395	480	565	650
			Total Pressure	0.019	0.049	0.092	0.149	0.221	0.306	0.405
			Ps	0.017	0.043	0.082	0.134	0.197	0.273	0.362
			NC	<10	<10	16	26	31	39	45
		Throw	5-9-17	10-15-24	14-18-25	17-20-29	18-22-32	20-24-34	21-26-37	
		5 ft.	CFM / ft	150	250	350	450	550	650	750
			Total Pressure	0.015	0.041	0.080	0.132	0.196	0.274	0.365
Ps	0.012		0.034	0.067	0.111	0.166	0.232	0.308		
NC	<10		<10	16	26	34	41	47		
Throw	4-9-18	10-15-23	14-19-27	18-22-31	19-24-34	21-26-37	23-28-39			

Linear Flow Bar High-Flow Diffusers

Plenum with adjustable high-flow slider - ALF17 Series



3.0" Slot Width	1-Slot 10" Inlet	2 ft.	CFM / ft	125	170	215	260	305	350	395
			Total Pressure	0.051	0.095	0.152	0.222	0.306	0.403	0.513
Ps	0.048	0.089	0.142	0.208	0.286	0.377	0.480			
NC	<10	<10	15	23	30	36	41			
Throw	7-11-16	10-13-19	12-15-21	13-17-23	15-18-25	16-19-27	17-20-30			
3.0" Slot Width	1-Slot 10" Inlet	4 ft.	CFM / ft	200	275	350	425	500	575	650
			Total Pressure	0.039	0.074	0.120	0.177	0.245	0.324	0.414
			Ps	0.031	0.058	0.094	0.139	0.192	0.254	0.325
			NC	<10	<10	17	25	29	36	42
			Throw	8-13-20	12-17-24	15-19-27	17-21-30	19-23-32	20-24-34	21-26-37
3.0" Slot Width	1-Slot 10" Inlet	5 ft.	CFM / ft	220	310	400	490	580	670	760
			Total Pressure	0.034	0.068	0.112	0.169	0.236	0.315	0.406
			Ps	0.024	0.047	0.079	0.118	0.166	0.221	0.284
			NC	<10	<10	17	25	33	40	46
			Throw	8-12-21	12-17-25	15-20-28	16-18-23-32	20-24-35	21-26-37	23-28-40
3.0" Slot Width	1-Slot 12" Inlet	2 ft.	CFM / ft	125	170	215	260	305	350	395
			Total Pressure	0.050	0.092	0.147	0.215	0.296	0.389	0.496
			Ps	0.048	0.089	0.142	0.208	0.286	0.377	0.480
			NC	<10	<10	11	19	26	32	37
			Throw	7-11-16	10-13-19	12-15-20	13-16-23	15-18-24	16-19-27	17-20-29
		4 ft.	CFM / ft	200	290	380	470	560	650	740
			Total Pressure	0.035	0.073	0.126	0.192	0.273	0.368	0.477
			Ps	0.031	0.065	0.111	0.170	0.241	0.325	0.421
			NC	<10	<10	16	26	31	40	44
		5 ft.	CFM / ft	220	330	440	550	660	770	880
			Total Pressure	0.029	0.065	0.115	0.180	0.259	0.352	0.460
			Ps	0.024	0.054	0.095	0.149	0.215	0.292	0.381
			Throw	8-13-20	12-17-24	16-20-28	18-22-31	20-24-34	21-26-37	23-28-39
3.0" Slot Width	1-Slot 12" Inlet	5 ft.	CFM / ft	<10	<10	17	26	34	41	46
			Total Pressure	0.029	0.065	0.115	0.180	0.259	0.352	0.460
			Ps	0.024	0.054	0.095	0.149	0.215	0.292	0.381
			NC	<10	<10	17	26	34	41	46
			Throw	8-12-21	12-18-26	16-21-30	19-24-34	21-26-37	23-28-40	25-30-43

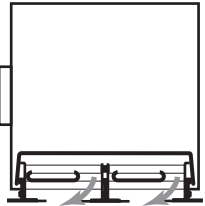
SYMBOLS Ps Static Pressure in inches of water
 Throw Vertical distances in feet to a terminal velocity of 150, 100 and 50 FPM
 NC Noise Criteria based on 10 db room absorption

LENGTH MULTIPLIERS AND ADJUSTMENTS
 Above data obtained with 4 foot long sections. For lengths other than 4', use the multipliers and adjustments in adjacent table.

Diffuser Length	2'	4'	6'	8'	10'
Throw Multiplier	0.7	1	1.2	1.5	1.8
NC Adjustment - Supply	-2	0	+2	+3	+4
NC Adjustment - Return	0	+3	+4	+5	+7

Data based on test results according to ANSI/ASHRAE 70-2006.

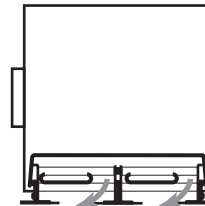
Linear Flow Bar High-Flow Diffusers Plenum with adjustable high-flow slider - ALF27 Series



1.0" Slot Width	2-Slot 8" Inlet	2 ft.	CFM / ft	80	120	160	200	240	280	320
			Total Pressure	0.021	0.048	0.085	0.133	0.192	0.261	0.341
			Ps	0.019	0.041	0.072	0.113	0.162	0.221	0.288
			NC	<10	<10	15	24	30	36	41
		Throw	3-6-13	6-10-17	9-13-18	11-14-20	13-16-22	14-17-24	15-18-26	
		4 ft.	CFM / ft	160	230	300	370	440	510	580
			Total Pressure	0.031	0.064	0.109	0.167	0.235	0.316	0.409
			Ps	0.018	0.037	0.064	0.096	0.136	0.183	0.237
			NC	<10	<10	18	25	32	37	42
		Throw	4-9-18	9-13-22	11-17-25	14-20-28	17-21-30	19-23-32	20-24-35	
		5 ft.	CFM / ft	200	280	360	440	520	600	680
			Total Pressure	0.039	0.075	0.125	0.186	0.260	0.347	0.445
Ps	0.018		0.035	0.058	0.087	0.122	0.162	0.208		
NC	<10		<10	18	26	31	36	41		
Throw	5-10-20	9-14-24	12-18-27	15-21-30	18-23-33	20-25-35	22-27-38			
1.0" Slot Width	2-Slot 10" Inlet	2 ft.	CFM / ft	80	130	180	230	280	330	380
			Total Pressure	0.019	0.051	0.098	0.160	0.238	0.329	0.437
			Ps	0.018	0.048	0.091	0.149	0.221	0.307	0.407
			NC	<10	<10	19	28	35	41	47
		Throw	3-6-13	7-11-16	10-14-19	12-15-22	14-17-24	15-18-26	16-20-28	
		4 ft.	CFM / ft	160	240	320	400	480	560	640
			Total Pressure	0.023	0.053	0.094	0.146	0.211	0.288	0.374
			Ps	0.018	0.041	0.072	0.113	0.162	0.221	0.288
			NC	<10	<10	19	27	34	40	45
		Throw	4-9-18	9-14-22	12-18-26	15-20-29	18-22-32	20-24-34	21-27-36	
		5 ft.	CFM / ft	200	295	390	485	580	675	770
			Total Pressure	0.026	0.057	0.100	0.155	0.222	0.302	0.392
Ps	0.018		0.039	0.069	0.106	0.152	0.205	0.267		
NC	<10		<10	20	28	34	40	45		
Throw	5-10-20	10-15-25	13-20-28	17-22-32	20-24-36	22-26-37	23-28-40			
1.5" Slot Width	2-Slot 8" Inlet	2 ft.	CFM / ft	120	160	200	240	280	320	360
			Total Pressure	0.040	0.071	0.111	0.160	0.217	0.283	0.359
			Ps	0.032	0.058	0.090	0.130	0.177	0.231	0.292
			NC	<10	11	20	26	32	37	41
		Throw	6-10-16	9-13-18	11-14-20	13-16-22	14-17-24	15-18-26	16-19-27	
		4 ft.	CFM / ft	240	310	380	450	520	590	660
			Total Pressure	0.062	0.103	0.155	0.218	0.291	0.375	0.469
			Ps	0.032	0.055	0.081	0.114	0.152	0.196	0.246
			NC	<10	15	22	28	34	38	43
		Throw	9-14-22	12-18-25	14-20-28	17-22-31	19-23-33	20-25-35	21-26-37	
		5 ft.	CFM / ft	300	370	440	510	580	650	720
			Total Pressure	0.079	0.120	0.169	0.227	0.294	0.369	0.453
Ps	0.031		0.049	0.070	0.094	0.121	0.152	0.187		
NC	<10		14	21	26	31	35	39		
Throw	10-15-25	13-19-29	15-21-30	17-23-32	20-24-35	21-26-37	22-27-39			
1.5" Slot Width	2-Slot 12" Inlet	2 ft.	CFM / ft	120	170	220	270	320	370	420
			Total Pressure	0.034	0.068	0.114	0.172	0.241	0.323	0.416
			Ps	0.032	0.065	0.109	0.164	0.231	0.309	0.398
			NC	<10	11	22	29	35	40	45
		Throw	6-10-16	9-13-19	12-15-21	14-17-24	15-18-26	16-20-28	17-21-29	
		4 ft.	CFM / ft	240	320	400	480	560	640	720
			Total Pressure	0.038	0.068	0.106	0.153	0.209	0.272	0.345
			Ps	0.032	0.058	0.090	0.131	0.177	0.231	0.292
			NC	<10	14	22	29	35	40	44
		Throw	9-14-22	12-18-26	15-20-29	18-22-32	20-24-34	21-26-36	22-27-39	
		5 ft.	CFM / ft	300	400	500	600	700	800	900
			Total Pressure	0.042	0.074	0.116	0.166	0.226	0.296	0.374
Ps	0.032		0.058	0.090	0.130	0.178	0.231	0.292		
NC	<10		15	24	31	36	41	46		
Throw	10-15-25	14-20-29	17-23-32	20-25-35	22-27-38	23-29-41	25-31-43			

Linear Flow Bar High-Flow Diffusers

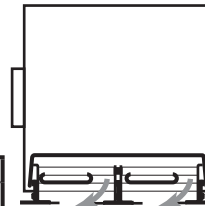
Plenum with adjustable high-flow slider - ALF27 Series



2.0" Slot Width	2-Slot 8" Inlet	2 ft.	CFM / ft	120	165	210	255	300	345	390
			Total Pressure	0.029	0.053	0.085	0.125	0.174	0.230	0.294
			Ps	0.020	0.039	0.063	0.092	0.128	0.169	0.216
			NC	<10	11	20	27	33	38	42
		Throw	5-9-16	8-12-18	10-15-21	12-16-23	14-18-25	15-19-27	16-20-28	
		4 ft.	CFM / ft	240	300	360	420	480	540	600
			Total Pressure	0.050	0.078	0.112	0.153	0.200	0.253	0.312
			Ps	0.020	0.031	0.046	0.063	0.082	0.103	0.128
			NC	12	21	27	33	38	43	47
		Throw	7-12-22	10-15-25	12-19-27	14-21-29	16-22-32	18-24-33	20-25-35	
		5 ft.	CFM / ft	260	325	390	455	520	585	650
			Total Pressure	0.050	0.078	0.112	0.153	0.200	0.253	0.312
Ps	0.015		0.024	0.034	0.045	0.061	0.078	0.096		
NC	11		20	26	32	37	42	46		
Throw	6-12-23	9-15-26	12-18-28	14-20-31	16-24-33	18-25-35	19-26-37			
2" Slot Width	2-Slot 12" Inlet	2 ft.	CFM / ft	120	195	270	345	420	495	570
			Total Pressure	0.022	0.058	0.111	0.181	0.268	0.372	0.493
			Ps	0.020	0.054	0.103	0.169	0.250	0.348	0.460
			NC	<10	<10	17	26	33	39	45
		Throw	5-9-16	9-14-20	13-17-24	15-19-27	17-21-29	18-23-32	20-24-34	
		4 ft.	CFM / ft	240	330	420	510	600	690	780
			Total Pressure	0.026	0.050	0.080	0.118	0.164	0.217	0.277
			Ps	0.020	0.039	0.063	0.092	0.128	0.169	0.216
			NC	<10	12	21	28	34	40	44
		Throw	7-12-22	11-17-26	14-21-29	17-23-32	20-25-35	22-27-38	23-28-40	
		5 ft.	CFM / ft	280	380	480	580	680	780	880
			Total Pressure	0.026	0.047	0.076	0.110	0.152	0.200	0.254
Ps	0.018		0.033	0.052	0.076	0.105	0.138	0.177		
NC	<10		14	22	29	35	40	45		
Throw	6-13-24	11-17-28	14-22-32	17-24-35	20-27-38	23-28-40	25-30-43			
2.5" Slot Width	2-Slot 10" Inlet	2 ft.	CFM / ft	80	160	240	320	400	480	560
			Total Pressure	0.007	0.027	0.061	0.109	0.171	0.247	0.334
			Ps	0.005	0.022	0.049	0.088	0.137	0.197	0.269
			NC	<10	<10	11	22	31	39	45
		Throw	2-4-11	7-11-18	11-16-22	14-18-26	17-20-29	18-22-32	20-24-34	
		4 ft.	CFM / ft	160	280	400	520	640	760	880
			Total Pressure	0.011	0.033	0.068	0.115	0.175	0.245	0.328
			Ps	0.005	0.017	0.034	0.058	0.088	0.124	0.166
			NC	<10	<10	15	26	35	42	48
		Throw	3-6-15	8-13-24	13-19-29	17-23-34	20-26-36	23-28-40	25-30-43	
		5 ft.	CFM / ft	200	335	470	605	740	875	1010
			Total Pressure	0.014	0.039	0.077	0.128	0.190	0.266	0.354
Ps	0.005		0.015	0.030	0.050	0.075	0.105	0.140		
NC	<10		<10	17	27	35	42	48		
Throw	3-6-17	8-14-26	13-20-31	17-25-35	21-28-39	25-30-43	26-32-46			
2.5" Slot Width	2-Slot 12" Inlet	2 ft.	CFM / ft	80	170	260	350	440	530	620
			Total Pressure	0.006	0.028	0.066	0.117	0.185	0.269	0.368
			Ps	0.005	0.025	0.058	0.105	0.166	0.241	0.329
			NC	<10	<10	<10	21	31	38	45
		Throw	2-4-11	8-12-19	12-16-23	16-19-27	17-21-30	19-23-33	21-25-36	
		4 ft.	CFM / ft	160	295	430	565	700	835	970
			Total Pressure	0.008	0.027	0.058	0.101	0.155	0.220	0.297
			Ps	0.006	0.019	0.040	0.068	0.105	0.149	0.202
			NC	<10	<10	13	25	33	41	47
		Throw	3-6-15	9-14-25	14-21-30	18-24-34	22-27-38	24-29-42	26-32-45	
		5 ft.	CFM / ft	200	350	500	650	800	950	1100
			Total Pressure	0.010	0.029	0.060	0.101	0.153	0.215	0.288
Ps	0.005		0.017	0.034	0.058	0.088	0.124	0.166		
NC	<10		<10	14	25	34	41	47		
Throw	3-6-18	9-15-27	14-21-32	19-26-37	23-29-41	26-31-44	28-34-48			

Linear Flow Bar Jet-Flow Diffusers

Plenum with adjustable high-flow slider - ALF27 Series



Slot Width	Inlet	Height	CFM / ft	80	180	280	380	480	580	680	
			Total Pressure	0.006	0.032	0.077	0.141	0.226	0.329	0.453	
Ps	0.006	0.025	0.060	0.111	0.177	0.259	0.356				
NC	<10	<10	<10	20	31	39	46				
Throw	1-3-10	7-12-19	12-17-24	16-20-28	18-22-32	20-24-35	22-27-38				
3.0"	2 Slot 10" Inlet	2 ft.	CFM / ft	150	300	450	600	750	900	1050	
			Total Pressure	0.009	0.036	0.081	0.145	0.226	0.326	0.444	
			Ps	0.004	0.017	0.040	0.069	0.108	0.156	0.212	
			NC	<10	<10	<10	22	32	41	48	
		Throw	2-4-13	7-13-25	13-20-31	18-25-35	22-28-39	25-31-43	27-33-47		
		4 ft.	CFM / ft	180	350	520	690	860	1030	1200	
	Total Pressure		0.011	0.041	0.090	0.159	0.246	0.353	0.480		
	Ps		0.004	0.015	0.033	0.059	0.091	0.131	0.177		
	NC		<10	<10	10	22	33	41	48		
	Throw	2-4-14	7-14-27	14-21-33	18-27-38	23-30-42	27-33-46	29-35-50			
	3.0"	2 Slot 12" Inlet	2 ft.	CFM / ft	80	180	280	380	480	580	680
				Total Pressure	0.006	0.028	0.068	0.126	0.201	0.293	0.403
Ps				0.005	0.025	0.060	0.111	0.177	0.259	0.356	
NC				<10	<10	<10	16	26	35	42	
Throw			1-3-10	7-11-19	12-16-24	16-20-28	18-22-32	20-24-35	22-27-38		
4 ft.			CFM / ft	150	310	470	630	790	950	1110	
		Total Pressure	0.007	0.028	0.065	0.117	0.183	0.265	0.362		
		Ps	0.004	0.019	0.043	0.076	0.120	0.174	0.237		
		NC	<10	<10	<10	19	30	38	45		
Throw		2-4-13	8-14-25	14-21-31	19-26-36	23-29-40	26-31-44	28-34-48			
5 ft.		CFM / ft	180	360	540	720	900	1080	1260		
		Total Pressure	0.007	0.029	0.065	0.116	0.182	0.262	0.356		
	Ps	0.004	0.016	0.036	0.064	0.100	0.144	0.197			
	NC	<10	<10	<10	20	30	38	45			
Throw	2-4-14	7-14-27	14-21-33	19-26-39	24-31-43	27-33-47	29-36-51				

SYMBOLS Ps Static Pressure in inches of water
 Throw Vertical distances in feet to a terminal velocity of 150, 100 and 50 FPM
 NC Noise Criteria based on 10 db room absorption

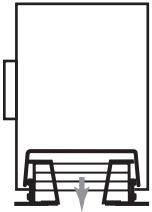
LENGTH MULTIPLIERS AND ADJUSTMENTS

Above data obtained with 4 foot long sections. For lengths other than 4', use the multipliers and adjustments in adjacent table.

Diffuser Length	2'	4'	6'	8'	10'
Throw Multiplier	0.7	1	1.2	1.5	1.8
NC Adjustment - Supply	-2	0	+2	+3	+4
NC Adjustment - Return	0	+3	+4	+5	+7

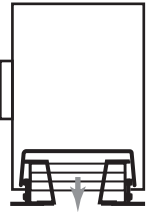
Data based on test results according to ANSI/ASHRAE 70-2006.

Linear Jet-Flow Diffusers Plenum with jet-flow baffles - ALF18 Series



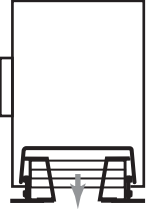
1.0" Slot Width	1-Slot 8" Inlet	2 ft.	CFM / ft	50	95	140	185	230	275	320
			Total Pressure	0.010	0.043	0.093	0.163	0.252	0.361	0.488
			Static Pressure	0.009	0.038	0.083	0.146	0.225	0.322	0.436
			NC	<10	<10	16	23	29	34	39
		Throw	2-3-6	4-5-12	5-8-14	7-11-16	9-13-18	11-14-20	12-15-22	
		4 ft.	CFM / ft	100	175	250	325	400	475	550
			Total Pressure	0.016	0.048	0.097	0.166	0.252	0.356	0.477
			Static Pressure	0.011	0.033	0.068	0.112	0.170	0.240	0.322
			NC	<10	<10	19	25	30	34	38
		Throw	3-4-8	5-7-14	7-10-19	9-12-22	11-17-24	13-19-26	15-20-28	
		5 ft.	CFM / ft	110	195	280	365	450	535	620
			Total Pressure	0.014	0.045	0.094	0.156	0.242	0.342	0.459
Static Pressure	0.008		0.026	0.053	0.091	0.141	0.195	0.262		
NC	<10		<10	17	24	28	33	37		
Throw	3-4-8	5-7-14	7-10-20	9-13-23	11-17-26	13-20-28	15-21-30			
1.0" Slot Width	1-Slot 10" Inlet	2 ft.	CFM / ft	50	95	140	185	230	275	320
			Total Pressure	0.011	0.040	0.088	0.153	0.236	0.337	0.457
			Static Pressure	0.011	0.038	0.083	0.146	0.225	0.322	0.436
			NC	<10	<10	16	22	28	33	39
		Throw	2-3-6	4-6-11	5-8-14	7-11-16	9-13-18	11-14-20	12-15-23	
		4 ft.	CFM / ft	100	180	260	340	420	500	580
			Total Pressure	0.013	0.041	0.086	0.147	0.225	0.318	0.427
			Static Pressure	0.011	0.034	0.072	0.123	0.188	0.267	0.358
			NC	<10	<10	18	25	30	35	39
		Throw	3-4-8	5-7-15	7-11-19	9-14-22	12-17-25	14-19-27	16-21-29	
		5 ft.	CFM / ft	110	210	310	410	510	610	710
			Total Pressure	0.011	0.039	0.086	0.150	0.234	0.331	0.449
Static Pressure	0.008		0.030	0.065	0.113	0.177	0.253	0.343		
NC	<10		<10	19	27	31	35	40		
Throw	3-4-8	5-8-16	8-11-21	10-15-24	13-19-27	15-21-30	18-23-32			
1.0" Slot Width	1-Slot 12" Inlet	2 ft.	CFM / ft	50	95	140	185	230	275	320
			Total Pressure	0.011	0.039	0.086	0.149	0.230	0.329	0.446
			Static Pressure	0.011	0.041	0.083	0.146	0.225	0.322	0.436
			NC	<10	<10	15	22	27	32	38
		Throw	2-3-6	4-6-11	5-8-14	7-11-16	9-13-18	11-14-20	12-15-22	
		4 ft.	CFM / ft	100	190	280	370	460	550	640
			Total Pressure	0.012	0.042	0.091	0.159	0.247	0.352	0.477
			Static Pressure	0.011	0.038	0.083	0.146	0.225	0.322	0.436
			NC	<10	10	19	26	32	37	42
		Throw	3-4-8	5-8-16	8-12-20	10-15-23	13-18-26	15-20-28	18-22-30	
		5 ft.	CFM / ft	110	220	330	440	550	660	770
			Total Pressure	0.008	0.038	0.085	0.151	0.237	0.341	0.464
Static Pressure	0.007		0.033	0.074	0.132	0.206	0.297	0.404		
NC	<10		<10	20	27	32	37	42		
Throw	3-4-8	5-8-16	8-12-22	11-16-25	14-20-28	16-22-31	19-24-33			
1.5" Slot Width	1-Slot 8" Inlet	2 ft.	CFM / ft	60	110	160	210	260	310	360
			Total Pressure	0.014	0.046	0.097	0.167	0.257	0.365	0.492
			Static Pressure	0.008	0.026	0.058	0.096	0.147	0.209	0.282
			NC	<10	<10	<10	16	24	31	37
		Throw	1-3-5	3-5-9	5-7-14	6-9-17	7-11-19	9-13-21	10-15-23	
		4 ft.	CFM / ft	120	180	240	300	360	420	480
			Total Pressure	0.031	0.070	0.125	0.195	0.280	0.382	0.498
			Static Pressure	0.008	0.018	0.031	0.049	0.069	0.096	0.125
			NC	<10	<10	<10	<10	16	22	27
		Throw	2-4-7	4-5-11	5-7-15	6-9-18	7-11-22	8-13-25	10-15-26	
		5 ft.	CFM / ft	140	200	260	320	380	440	500
			Total Pressure	0.039	0.079	0.133	0.201	0.284	0.383	0.492
Static Pressure	0.007		0.014	0.024	0.036	0.050	0.067	0.089		
NC	<10		<10	<10	<10	12	17	22		
Throw	2-4-8	4-5-11	5-7-14	6-9-17	7-10-21	8-12-24	9-14-27			

Linear Jet-Flow Diffusers Plenum with jet-flow baffles - ALF18 Series



1.5" Slot Width	1-Slot 8" Inlet	2 ft.	CFM / ft	60	125	190	255	320	385	450
			Total Pressure	0.010	0.037	0.086	0.155	0.244	0.354	0.483
			Ps	0.009	0.033	0.079	0.141	0.223	0.322	0.441
			NC	<10	<10	<10	19	28	36	44
		Throw	1-3-5	4-5-10	5-8-16	7-11-19	9-14-22	11-17-24	13-18-26	
		4 ft.	CFM / ft	120	230	340	450	560	670	780
			Total Pressure	0.011	0.040	0.089	0.153	0.236	0.338	0.459
			Ps	0.008	0.029	0.065	0.110	0.171	0.244	0.331
			NC	<10	<10	10	20	29	36	42
		Throw	2-4-7	5-7-14	7-10-21	9-13-26	11-17-29	14-20-31	16-24-34	
		5 ft.	CFM / ft	140	265	390	516	640	765	890
			Total Pressure	0.011	0.039	0.085	0.148	0.228	0.327	0.442
Ps	0.007		0.024	0.053	0.092	0.145	0.204	0.276		
NC	<10		<10	<10	19	28	34	40		
Throw	2-4-8	5-7-14	7-11-21	9-14-27	12-17-30	14-20-33	16-24-36			
1.5" Slot Width	1-Slot 10" Inlet	2 ft.	CFM / ft	60	125	190	255	320	385	450
			Total Pressure	0.008	0.036	0.082	0.148	0.233	0.335	0.461
			Ps	0.008	0.034	0.079	0.141	0.223	0.322	0.442
			NC	<10	<10	<10	18	27	35	43
		Throw	1-3-5	4-5-11	5-8-16	7-11-19	9-14-22	11-17-24	13-19-26	
		4 ft.	CFM / ft	120	240	360	480	600	720	840
			Total Pressure	0.009	0.037	0.084	0.149	0.232	0.334	0.453
			Ps	0.008	0.031	0.070	0.125	0.196	0.282	0.386
			NC	<10	<10	10	21	30	37	45
		Throw	2-4-7	5-7-15	7-11-22	10-15-26	12-18-30	14-21-32	17-25-35	
		5 ft.	CFM / ft	140	280	420	560	700	840	980
			Total Pressure	0.009	0.035	0.079	0.141	0.222	0.317	0.432
Ps	0.007		0.027	0.061	0.109	0.173	0.246	0.334		
NC	<10		<10	10	20	28	36	43		
Throw	2-4-8	5-8-15	8-11-23	10-15-28	13-19-32	15-23-35	18-27-38			
2.0" Slot Width	1-Slot 12" Inlet	2 ft.	CFM / ft	70	140	210	280	350	420	490
			Total Pressure	0.008	0.033	0.075	0.131	0.206	0.296	0.403
			Ps	0.006	0.023	0.051	0.092	0.143	0.206	0.280
			NC	<10	<10	14	21	27	33	38
		Throw	1-2-5	3-5-10	5-7-15	7-10-20	8-12-23	10-15-25	12-17-27	
		4 ft.	CFM / ft	140	240	340	440	540	640	740
			Total Pressure	0.016	0.045	0.093	0.156	0.235	0.329	0.440
			Ps	0.005	0.017	0.034	0.057	0.085	0.120	0.160
			NC	<10	12	21	27	32	36	40
		Throw	1-3-7	4-6-12	6-9-17	7-11-22	9-14-27	11-16-30	12-19-33	
		5 ft.	CFM / ft	150	260	370	480	590	700	810
			Total Pressure	0.015	0.047	0.096	0.161	0.243	0.343	0.459
Ps	0.003		0.013	0.026	0.043	0.065	0.092	0.123		
NC	<10		13	21	27	32	36	40		
Throw	1-3-7	3-6-12	6-8-17	7-11-22	9-13-27	10-16-31	12-18-34			
2.0" Slot Width	1-Slot 8" Inlet	2 ft.	CFM / ft	70	150	230	310	390	470	550
			Total Pressure	0.007	0.031	0.075	0.132	0.210	0.304	0.417
			Ps	0.006	0.026	0.064	0.112	0.178	0.258	0.353
			NC	<10	<10	11	18	26	31	36
		Throw	1-2-5	4-5-11	5-8-16	7-11-21	9-14-24	11-17-26	13-20-28	
		4 ft.	CFM / ft	140	265	390	515	640	765	890
			Total Pressure	0.010	0.035	0.076	0.132	0.207	0.294	0.398
			Ps	0.006	0.021	0.044	0.077	0.122	0.171	0.231
			NC	<10	10	19	25	31	36	41
		Throw	1-3-7	4-7-13	7-10-20	9-13-26	11-16-30	13-19-33	15-22-36	
		5 ft.	CFM / ft	150	300	450	600	750	900	1050
			Total Pressure	0.009	0.036	0.080	0.143	0.223	0.323	0.437
Ps	0.004		0.017	0.038	0.067	0.105	0.151	0.204		
NC	<10		11	21	27	33	37	42		
Throw	1-3-7	4-7-13	7-10-20	9-13-27	11-17-33	13-20-36	16-24-38			

Linear Jet-Flow Diffusers Plenum with jet-flow baffles - ALF18 Series



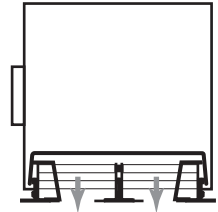
Slot Width	Inlet	Height	CFM / ft	70	160	250	340	430	520	610
			Total Pressure	0.007	0.032	0.079	0.147	0.235	0.343	0.472
2.0"	1-Slot 12" Inlet	2 ft.	Ps	0.006	0.031	0.073	0.135	0.216	0.316	0.435
			NC	<10	<10	<10	17	25	31	36
			Throw	1-2-5	4-6-11	6-9-18	8-12-22	10-15-25	12-18-27	14-21-30
		4 ft.	CFM / ft	140	290	440	590	740	890	1040
			Total Pressure	0.008	0.033	0.075	0.136	0.215	0.311	0.425
			Ps	0.006	0.025	0.057	0.100	0.160	0.231	0.316
		5 ft.	NC	<10	<10	17	24	30	37	41
			Throw	1-3-7	5-7-15	7-11-22	10-15-29	13-19-33	15-22-36	17-26-39
			CFM / ft	150	330	510	690	870	1050	1230
2.5"	1-Slot 12" Inlet	2 ft.	Total Pressure	0.006	0.031	0.075	0.137	0.218	0.320	0.436
			Ps	0.004	0.020	0.049	0.089	0.141	0.208	0.283
			NC	<10	<10	19	26	32	38	43
		4 ft.	Throw	1-3-7	5-7-15	8-11-23	10-16-31	13-20-36	16-24-39	18-28-42
			CFM / ft	80	190	300	410	520	630	740
			Total Pressure	0.005	0.031	0.077	0.143	0.231	0.339	0.465
		5 ft.	Ps	0.005	0.027	0.068	0.126	0.203	0.300	0.412
			NC	<10	<10	<10	12	20	27	33
			Throw	1-2-5	4-6-12	6-9-19	9-13-24	11-16-27	13-20-30	15-23-33
3.0"	1-Slot 12" Inlet	2 ft.	CFM / ft	150	335	520	705	890	1075	1260
			Total Pressure	0.007	0.032	0.078	0.146	0.228	0.334	0.459
			Ps	0.004	0.021	0.051	0.095	0.149	0.217	0.298
		4 ft.	NC	<10	<10	<10	18	26	32	38
			Throw	1-2-7	5-7-15	8-11-23	10-16-31	13-20-36	16-24-40	18-28-43
			CFM / ft	160	370	580	790	1000	1210	1420
		5 ft.	Total Pressure	0.006	0.032	0.075	0.138	0.222	0.324	0.447
			Ps	0.003	0.018	0.040	0.075	0.120	0.176	0.243
			NC	<10	<10	<10	18	26	32	38
2.0"	1-Slot 12" Inlet	2 ft.	Throw	1-3-6	5-7-15	8-11-23	10-16-31	13-20-38	16-24-42	19-28-45
			CFM / ft	100	225	350	475	600	725	850
			Total Pressure	0.005	0.031	0.076	0.140	0.224	0.327	0.449
		4 ft.	Ps	0.004	0.025	0.064	0.117	0.187	0.274	0.376
			NC	<10	<10	<10	<10	15	24	31
			Throw	1-2-6	4-6-12	6-10-19	9-13-26	11-17-30	13-20-32	16-24-35
		5 ft.	CFM / ft	200	400	600	800	1000	1200	1400
			Total Pressure	0.009	0.037	0.082	0.147	0.231	0.333	0.454
			Ps	0.005	0.021	0.047	0.082	0.130	0.187	0.255
3.0"	1-Slot 12" Inlet	4 ft.	NC	<10	<10	<10	<10	17	25	32
			Throw	1-3-8	5-8-16	8-12-24	10-16-31	13-20-38	16-24-42	18-27-45
			CFM / ft	240	460	680	900	1120	1340	1560
5 ft.	Total Pressure	0.011	0.039	0.085	0.149	0.231	0.333	0.449		
	Ps	0.005	0.018	0.039	0.067	0.105	0.151	0.203		
	NC	<10	<10	<10	<10	15	24	30		
3.0"	1-Slot 12" Inlet	5 ft.	Throw	1-3-8	5-8-16	8-12-24	11-16-32	13-20-39	16-23-44	18-27-49

SYMBOLS Ps Static Pressure in inches of water
 Throw Vertical distances in feet to a terminal velocity of 150, 100 and 50 FPM
 NC Noise Criteria based on 10 db room absorption

LENGTH MULTIPLIERS AND ADJUSTMENTS
 Above data obtained with 4 foot long sections. For lengths other than 4', use the multipliers and adjustments in adjacent table.

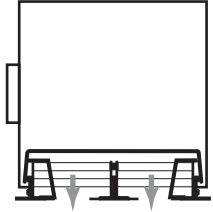
Data based on test results according to ANSI/ASHRAE 70-2006.

Linear Jet-Flow Diffusers Plenum with jet-flow baffles - ALF28 Series



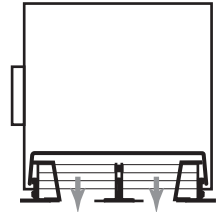
1.0" Slot Width	2-Slot 8" Inlet	2 ft.	CFM / ft	80	155	230	305	380	455	530
			Total Pressure	0.009	0.038	0.083	0.147	0.228	0.326	0.443
			Ps	0.006	0.026	0.056	0.099	0.154	0.220	0.299
			NC	<10	<10	16	23	29	33	37
			Throw	2-3-7	4-7-13	6-10-18	8-13-21	10-16-23	13-18-26	15-20-28
		CFM / ft	160	260	360	460	560	660	760	
	4 ft.	Total Pressure	0.020	0.053	0.103	0.165	0.244	0.339	0.450	
		Ps	0.007	0.018	0.036	0.056	0.083	0.116	0.154	
		NC	<10	<10	16	21	26	30	33	
		Throw	3-5-9	5-8-15	7-11-21	9-14-26	11-16-29	13-19-31	15-22-33	
		CFM / ft	200	300	400	500	600	700	800	
	5 ft.	Total Pressure	0.027	0.061	0.109	0.173	0.248	0.334	0.437	
Ps		0.007	0.015	0.027	0.043	0.061	0.083	0.109		
NC		<10	<10	13	19	24	27	30		
Throw		3-5-10	5-8-16	7-10-21	9-13-26	10-15-30	12-18-32	14-21-34		
CFM / ft		80	165	250	335	420	505	590		
1.0" Slot Width	1-Slot 12" Inlet	2 ft.	Total Pressure	0.008	0.035	0.080	0.143	0.225	0.327	0.443
			Ps	0.007	0.029	0.066	0.119	0.188	0.271	0.396
			NC	<10	<10	17	25	30	35	40
			Throw	2-3-7	5-7-14	7-10-19	9-14-22	12-17-25	14-19-27	16-21-29
			CFM / ft	160	300	440	580	720	860	1000
		4 ft.	Total Pressure	0.012	0.043	0.092	0.160	0.247	0.352	0.478
	Ps		0.007	0.024	0.051	0.089	0.138	0.197	0.265	
	NC		<10	<10	19	26	31	35	39	
	Throw		3-5-9	6-9-18	9-13-25	11-17-29	14-21-32	17-24-35	19-27-38	
	CFM / ft		200	350	500	650	800	950	1100	
	5 ft.	Total Pressure	0.015	0.047	0.095	0.161	0.245	0.343	0.460	
		Ps	0.007	0.021	0.043	0.072	0.111	0.154	0.206	
NC		<10	<10	18	24	30	34	37		
Throw		3-5-10	6-9-18	9-13-26	11-17-31	14-21-34	17-25-37	19-28-40		
CFM / ft		80	170	260	350	440	530	620		
1.0" Slot Width	2-Slot 12" Inlet	2 ft.	Total Pressure	0.007	0.034	0.081	0.143	0.226	0.327	0.448
			Ps	0.007	0.031	0.076	0.130	0.206	0.299	0.409
			NC	<10	<10	18	25	31	36	41
			Throw	2-3-7	5-7-15	7-11-19	10-14-23	12-18-25	15-20-28	17-21-30
			CFM / ft	160	320	480	640	800	960	1120
		4 ft.	Total Pressure	0.010	0.040	0.085	0.150	0.235	0.338	0.461
	Ps		0.008	0.027	0.061	0.109	0.170	0.245	0.334	
	NC		<10	10	20	27	33	37	42	
	Throw		3-5-10	6-9-19	9-14-26	12-19-30	16-23-34	19-26-37	22-29-40	
	CFM / ft		200	375	550	725	900	1075	1250	
	5 ft.	Total Pressure	0.009	0.038	0.082	0.143	0.220	0.314	0.424	
		Ps	0.006	0.024	0.051	0.089	0.138	0.197	0.266	
NC		<10	10	20	26	32	36	40		
Throw		3-5-10	7-9-20	10-14-28	13-19-32	16-24-36	19-28-40	22-30-43		
CFM / ft		120	210	300	390	480	570	660		
1.5" Slot Width	2-Slot 8" Inlet	2 ft.	Total Pressure	0.015	0.047	0.097	0.161	0.243	0.343	0.460
			Ps	0.008	0.024	0.051	0.083	0.125	0.177	0.237
			NC	<10	<10	<10	17	25	31	37
			Throw	2-4-7	4-6-13	6-9-19	8-12-24	10-15-26	12-17-29	13-20-31
			CFM / ft	240	340	440	540	640	740	840
		4 ft.	Total Pressure	0.037	0.075	0.126	0.191	0.266	0.355	0.458
	Ps		0.008	0.016	0.026	0.040	0.057	0.074	0.096	
	NC		<10	<10	<10	<10	15	21	26	
	Throw		2-5-10	5-7-15	6-9-19	8-12-23	9-14-28	11-16-32	12-18-35	
	CFM / ft		260	365	470	575	680	785	890	
	5 ft.	Total Pressure	0.041	0.080	0.132	0.198	0.277	0.371	0.475	
		Ps	0.006	0.012	0.019	0.029	0.040	0.055	0.070	
NC		<10	<10	<10	<10	11	17	21		
Throw		2-5-10	4-7-14	6-9-18	7-11-22	9-13-26	10-15-31	11-17-35		

Linear Jet-Flow Diffusers Plenum with jet-flow baffles - ALF28 Series



1.5" Slot Width	2-Slot 10" Inlet	2 ft.	CFM / ft	120	230	340	450	560	670	780
			Total Pressure	0.012	0.040	0.087	0.153	0.236	0.338	0.459
			Ps	0.009	0.029	0.063	0.110	0.171	0.244	0.331
			NC	<10	<10	10	20	29	36	42
		Throw	2-4-7	4-7-13	7-10-21	9-14-26	11-17-29	14-20-31	16-24-34	
		4 ft.	CFM / ft	240	390	540	690	840	990	1140
			Total Pressure	0.020	0.053	0.103	0.165	0.244	0.339	0.449
			Ps	0.008	0.021	0.042	0.065	0.096	0.133	0.177
			NC	<10	<10	<10	16	24	30	35
		Throw	2-5-10	6-8-17	8-12-24	10-14-30	12-18-35	14-21-38	16-24-41	
		5 ft.	CFM / ft	260	425	590	755	920	1085	1250
			Total Pressure	0.020	0.054	0.103	0.171	0.253	0.350	0.464
Ps	0.006		0.016	0.030	0.052	0.076	0.102	0.136		
NC	<10		<10	<10	13	21	27	32		
Throw	2-5-10	5-8-16	8-11-23	10-14-29	12-18-35	14-21-39	16-24-43			
1.5" Slot Width	2-Slot 12" Inlet	2 ft.	CFM / ft	120	240	360	480	600	720	840
			Total Pressure	0.009	0.037	0.084	0.149	0.232	0.332	0.455
			Ps	0.008	0.031	0.070	0.125	0.196	0.282	0.386
			NC	<10	<10	10	21	30	37	45
		Throw	2-4-7	5-7-15	7-11-22	10-15-26	12-18-30	15-22-32	17-25-36	
		4 ft.	CFM / ft	240	415	590	765	940	1115	1290
			Total Pressure	0.014	0.041	0.083	0.139	0.210	0.295	0.393
			Ps	0.008	0.023	0.047	0.080	0.120	0.168	0.224
			NC	<10	<10	<10	19	27	33	39
		Throw	2-5-10	6-9-18	8-13-25	11-16-33	13-20-37	16-24-40	18-28-43	
		5 ft.	CFM / ft	260	440	620	800	980	1160	1340
			Total Pressure	0.013	0.036	0.072	0.120	0.183	0.253	0.338
Ps	0.006		0.017	0.033	0.056	0.086	0.117	0.156		
NC	<10		<10	<10	15	22	28	34		
Throw	2-5-10	6-8-17	8-12-24	10-16-31	13-19-38	15-22-41	17-26-44			
2.0" Slot Width	2-Slot 8" Inlet	2 ft.	CFM / ft	70	140	210	280	350	420	490
			Total Pressure	0.008	0.033	0.076	0.134	0.206	0.296	0.403
			Ps	0.006	0.017	0.036	0.057	0.085	0.120	0.160
			NC	<10	12	20	27	32	36	40
		Throw	1-3-7	4-6-12	5-9-17	7-11-22	9-14-27	11-16-30	12-19-33	
		4 ft.	CFM / ft	250	355	460	565	670	775	880
			Total Pressure	0.037	0.076	0.124	0.187	0.263	0.352	0.453
			Ps	0.004	0.009	0.015	0.023	0.033	0.044	0.057
			NC	<10	17	23	28	32	35	38
		Throw	2-3-10	3-6-13	5-8-16	7-10-20	8-12-24	9-14-28	10-16-31	
		5 ft.	CFM / ft	280	390	500	610	720	830	940
			Total Pressure	0.042	0.085	0.140	0.208	0.290	0.385	0.494
Ps	0.003		0.007	0.012	0.017	0.024	0.032	0.041		
NC	10		18	24	28	32	36	38		
Throw	1-3-9	3-6-12	4-8-16	6-10-19	8-11-23	9-13-26	10-15-30			
2.0" Slot Width	2-Slot 10" Inlet	2 ft.	CFM / ft	140	275	410	545	680	815	950
			Total Pressure	0.010	0.038	0.086	0.149	0.232	0.333	0.453
			Ps	0.006	0.022	0.051	0.087	0.135	0.194	0.263
			NC	<10	10	19	27	32	38	43
		Throw	1-3-7	5-7-14	7-11-21	9-14-26	11-17-31	14-20-34	16-24-37	
		4 ft.	CFM / ft	250	425	600	775	950	1125	1300
			Total Pressure	0.018	0.051	0.102	0.170	0.257	0.358	0.478
			Ps	0.005	0.013	0.026	0.044	0.068	0.092	0.123
			NC	<10	16	24	30	34	39	42
		Throw	2-3-9	4-8-15	7-11-21	9-14-28	11-17-34	13-20-40	15-23-43	
		5 ft.	CFM / ft	280	460	640	820	1000	1180	1360
			Total Pressure	0.020	0.054	0.105	0.173	0.257	0.359	0.475
Ps	0.004		0.010	0.019	0.031	0.047	0.065	0.085		
NC	<10		16	24	30	35	39	42		
Throw	1-3-9	4-7-15	7-10-20	9-13-26	11-16-32	12-19-37	14-22-42			

Linear Jet-Flow Diffusers Plenum with jet-flow baffles - ALF28 Series



2.0" Slot Width	2-Slot 12" Inlet	2 ft.	CFM / ft	140	280	420	560	700	840	980
			Total Pressure	0.011	0.031	0.069	0.130	0.193	0.277	0.378
			Ps	0.007	0.023	0.052	0.092	0.143	0.206	0.280
			NC	<10	<10	16	24	29	35	40
		Throw	1-3-7	4-7-14	7-11-20	9-14-28	12-18-32	14-21-35	16-25-38	
		4 ft.	CFM / ft	250	450	650	850	1050	1250	1450
			Total Pressure	0.080	0.035	0.076	0.132	0.192	0.272	0.390
			Ps	0.005	0.015	0.031	0.051	0.080	0.114	0.153
			NC	<10	13	22	28	33	37	42
		Throw	2-3-9	5-8-16	8-12-23	10-15-30	13-18-37	15-22-43	17-26-46	
		5 ft.	CFM / ft	280	480	680	880	1080	1280	1480
			Total Pressure	0.012	0.034	0.070	0.115	0.173	0.244	0.324
Ps	0.004		0.011	0.022	0.036	0.054	0.078	0.102		
NC	<10		13	21	27	32	36	40		
Throw	1-3-9	4-8-15	7-11-22	9-14-28	11-17-34	14-20-41	16-24-46			
2.5" Slot Width	2-Slot 12" Inlet	2 ft.	CFM / ft	150	335	520	705	890	1075	1260
			Total Pressure	0.010	0.032	0.078	0.150	0.229	0.334	0.479
			Ps	0.004	0.021	0.051	0.093	0.149	0.218	0.299
			NC	<10	<10	<10	18	26	33	39
		Throw	1-2-7	5-7-15	8-11-23	10-16-31	13-20-35	16-24-40	18-27-43	
		4 ft.	CFM / ft	300	540	780	1020	1260	1500	1740
			Total Pressure	0.010	0.043	0.090	0.162	0.235	0.334	0.449
			Ps	0.004	0.014	0.029	0.050	0.075	0.106	0.142
			NC	<10	<10	<10	18	25	31	36
		Throw	1-3-9	5-8-17	8-12-24	11-16-32	13-20-39	16-23-47	18-27-50	
		5 ft.	CFM / ft	350	600	850	1100	1350	1600	1850
			Total Pressure	0.020	0.049	0.095	0.170	0.239	0.336	0.480
Ps	0.004		0.012	0.022	0.036	0.055	0.077	0.103		
NC	<10		<10	<10	16	24	30	35		
Throw	1-4-10	4-8-17	8-12-24	10-15-31	13-19-38	15-22-45	17-26-51			
3.0" Slot Width	2-Slot 12" Inlet	2 ft.	CFM / ft	175	385	595	805	1015	1225	1435
			Total Pressure	0.009	0.034	0.082	0.160	0.238	0.347	0.477
			Ps	0.003	0.019	0.046	0.084	0.134	0.195	0.268
			NC	<10	<10	<10	<12	18	26	33
		Throw	1-4-7	5-8-15	8-13-23	11-17-32	13-20-38	16-24-42	19-28-46	
		4 ft.	CFM / ft	320	580	840	1100	1360	1620	1880
			Total Pressure	0.080	0.050	0.102	0.170	0.270	0.330	0.510
			Ps	0.003	0.011	0.023	0.041	0.060	0.085	0.115
			NC	<10	<10	<10	<10	16	24	31
		Throw	1-4-9	4-9-16	8-13-23	10-17-30	12-21-38	15-25-45	17-29-52	
		5 ft.	CFM / ft	380	645	910	1175	1440	1705	1970
			Total Pressure	0.020	0.051	0.101	0.180	0.253	0.357	0.510
Ps	0.003		0.009	0.017	0.029	0.043	0.062	0.081		
NC	<10		<10	<10	<10	<10	13	26		
Throw	1-4-9	3-8-16	7-11-23	10-16-29	12-18-36	14-21-42	16-27-48			

SYMBOLS Ps Static Pressure in inches of water
 Throw Vertical distances in feet to a terminal velocity of 150, 100 and 50 FPM
 NC Noise Criteria based on 10 db room absorption

LENGTH MULTIPLIERS AND ADJUSTMENTS

Above data obtained with 4 foot long sections. For lengths other than 4', use the multipliers and adjustments in adjacent table.

Data based on test results according to ANSI/ASHRAE 70-2006.

SLOT DIFFUSERS



Rev. 7

ALS SERIES SLOT DIFFUSER

For Ceiling, Sidewall and Sill Installation

MODELS (Slot Width)

ALS10 / ALS17 – 1" slot

ALS20 / ALS27 – 1/2" slot

ALS30 / ALS37 – 3/4" slot

ALS40 / ALS47 – 1 1/4" slot (New!)

ALS50 / ALS57 – 1 1/2" slot (New!)

Two Configuration Options

ALSx0 – without pattern-control damper (Return)

ALSx7 – with pattern-control damper (Supply Diffuser)

The Airvector® **ALS** Architectural Linear Slot Diffusers are designed for ceiling, sidewall, or sill installation and are recommended for supplying heated, ventilated, or cooled air, as well as returning or exhausting room air. Air pattern directional changes through 180° are achieved by the integral “**UNIFLEX**” combination pattern and volume controller, allowing field adjustment to meet changing requirements.

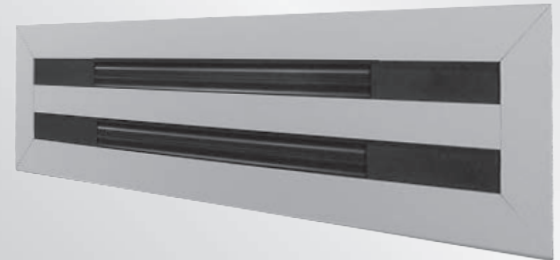
Their reliable performance supports cooling temperature differentials up to 25°F at predicted low air motion of 35 FPM in the occupied zone. ALS supply diffusers perform efficiently with air loadings of 1 to 3 CFM/ft² of floor area or 6 to 18 air changes per hour (based on a 10 ft ceiling height), with a typical sound range of NC 25 to 35.

ALS diffusers are fabricated from high-quality **aluminum** extrusions with a dull black pattern controller to accent the slot opening, and mechanically interlocked components for a clean, blemish-free appearance. Sections over 72" are furnished for field butting using keyways/splice plates, and 90° mitered corners are available.

For return/exhaust applications, **ALS** sections are identical to supply units except the pattern controller is removed to increase air capacity.

**Integral Airvector® UNIFLEX
pattern and volume controller**

New! Clean drywall finish with a plaster-in frame (-P).



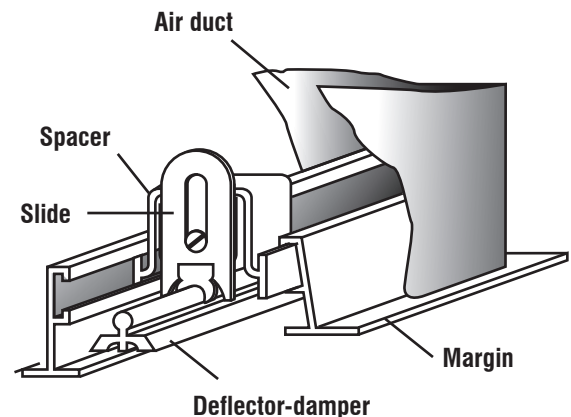
ALS37

KEY FEATURES

- 5 slot sizes 1", 1/2", 3/4", 1 1/4" and 1 1/2".
- 1 to 8 slots wide; per linear foot
- Extruded aluminum construction; mechanically interlocked assembly
- 180° “UNIFLEX” pattern/volume controller (ALSx7); ALSx0 without controller (for return/exhaust applications)
- Mounting types: **-E** Surface, **-T** T-Bar, **-P** Plaster-In Frame (**NEW!**) (ceiling, sidewall, or sill installations)
- Continuous-run capability: keyway splices and one-piece mitered corners for clean linear layouts
- Performance reference: cooling ΔT up to 25°F at 35 fpm (occupied zone), typical NC 25–35

OPTIONS & ACCESSORIES

- Optional frame gasket (**-GK**)
- PF Easy Install Frame (drywall applications)
- Standard white powder-coated finish; custom colors available.



DATA SHEET

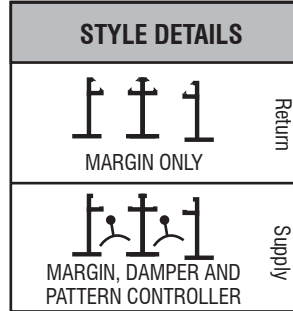
270

ARCHITECTURAL STYLES



ALS SERIES SLOT DIFFUSER

LISTED SIZES AVAILABLE
Any fractional inch increment of length 12" to 72"
One to ten slots
Lengths longer than 72" will be furnished in multiple sections for field butting.
Custom Paint - Lengths over 60" will be furnished in multiple sections



HOW TO ORDER ALS SERIES

ALS37-E-4-GK 48 2 /W

MODEL SERIES
 1" Slot Diffuser **ALS17**
 1" Slot Return **ALS10**
 1/2" Slot Diffuser **ALS27**
 1/2" Slot Return **ALS20**
 3/4" Slot Diffuser **ALS37**
 3/4" Slot Return **ALS30**

MARGIN STYLE
 Sidewall **-E**
 T-Bar Lay-In **-T**

FASTENING
 No Fastening **-1**
 Screw Fastening **-3**
 Concealed Mounting **-4**

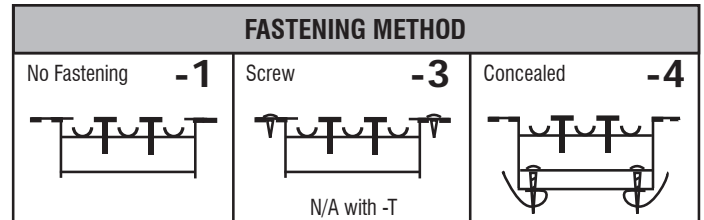
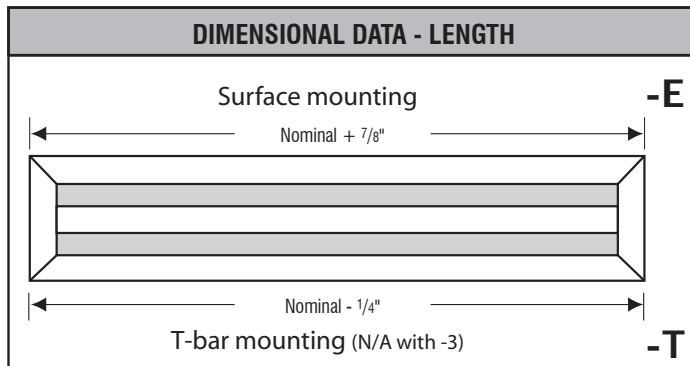
FINISH (OPTIONAL)
 Standard is White (**/W**)
 See chart for more

NUMBER OF SLOTS
 1-8

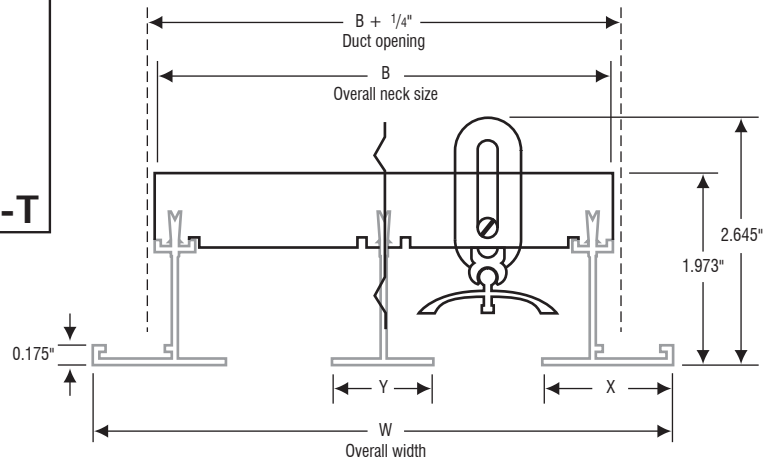
LENGTH (INCHES)
 48

Frame Gasket **-GK**

Series ALS products include a 1/32" tolerance for thermal expansion based on +40 degree F temperature differential. For every +20 degree F differential above +40 degree F, reduce required listed length by 1/64" per 5 feet of length.



1/2" SLOT		3/4" SLOT		1" SLOT	
X	Y	X	Y	X	Y
1 1/8"	11/16"	1 1/8"	11/16"	1 1/4"	1"



1/2" SLOT

SLOTS	B	W
1	1 9/16"	2 23/32"
2	2 3/4"	3 29/32"
3	3 15/16"	5 3/32"
4	5 1/8"	6 9/32"
5	6 5/16"	7 15/32"
6	7 1/2"	8 21/32"
7	8 11/16"	9 27/32"
8	9 7/8"	11 1/32"

3/4" SLOT

SLOTS	B	W
1	1 13/16"	2 31/32"
2	3 1/4"	4 13/32"
3	4 11/16"	5 27/32"
4	6 1/8"	7 9/32"
5	7 9/16"	8 23/32"
6	9"	10 5/32"
7	10 7/16"	11 19/32"
8	11 7/8"	13 1/32"

1" SLOT

SLOTS	B	W
1	2 3/8"	3 17/32"
2	4 3/8"	5 17/32"
3	6 3/8"	7 17/32"
4	8 3/8"	9 17/32"
5	10 3/8"	11 17/32"
6	12 3/8"	13 17/32"
7	14 3/8"	15 17/32"
8	16 3/8"	17 17/32"

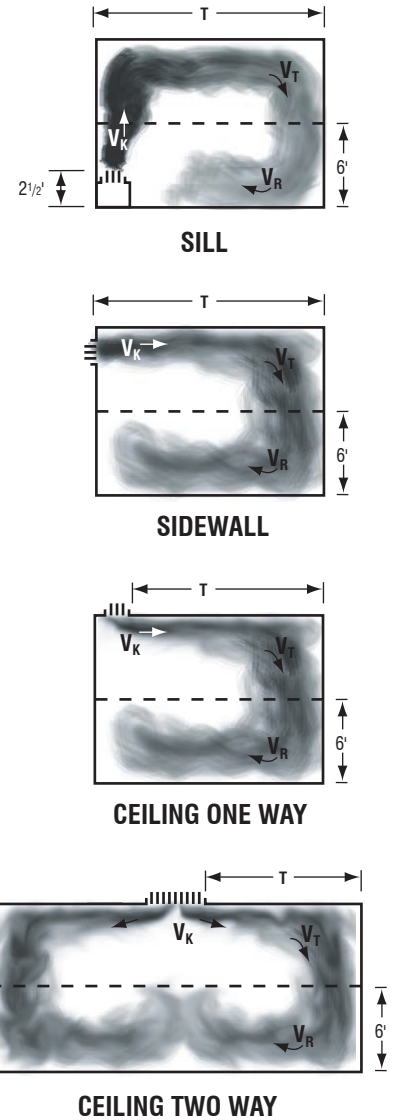
ENGINEERING PERFORMANCE DATA

ALS17 1" SLOT SUPPLY DIFFUSER



TABLE 1 SUPPLY AIR

CFM per Foot in Direction of T	No. of Slots	Min. P _s In. H ₂ O	Outlet Velocity (V _k) FPM	Throw (T) in Feet			Minimum Ceiling Height in Feet		NC
				Ceiling	Sidewall	Sill	in Feet		
				Min.-Max.	Min.-Max.	Min.-Max.	@ -18F ΔT	@ -25F ΔT	
20	1	.02	500	6-8	4-7	1-2	8	9	20
30	1	.03	750	9-13	7-10	2-3	9	10	20
	2	.02	500	7-9	5-7	1-2			20
40	1	.06	1000	10-14	9-14	4-6	9	11	25
	2	.03	670	8-10	6-9	2-3			20
50	1	.09	1250	12-15	10-14	3-5	9 1/2	11	31
	2	.04	835	10-14	8-12	3-4			20
	3	.02	555	9-11	7-10	2-3			20
60	2	.06	1000	15-18	9-13	4-6	9 1/2	12	30
	3	.03	665	10-13	7-11	2-4			20
	4	.02	500	8-11	6-9	2-3			20
70	2	.09	1165	13-17	11-15	5-8	10	12	30
	3	.04	780	11-16	9-14	4-6			25
	4	.02	585	10-14	7-11	3-4			20
80	2	.11	1335	15-19	14-17	6-10	10 1/2	12 1/2	35
	3	.05	890	12-17	10-14	4-7			25
	4	.03	665	10-14	8-12	3-5			20
	5	.02	533	9-13	7-11	2-4			20
	6	.02	500	8-11	6-9	2-3			20
90	3	.06	1000	14-19	11-17	5-10	11	13	30
	4	.04	750	13-18	11-15	4-8			20
	5	.02	600	12-16	10-14	3-7			20
	6	.02	500	11-15	9-13	3-6			20
	7	.02	500	10-14	8-12	3-5			20
	8	.02	500	9-13	7-11	2-4			20
100	3	.08	1110	16-21	14-20	7-12	11	13	30
	4	.04	835	15-20	13-18	6-11			25
	5	.03	665	14-18	12-16	5-9			20
	6	.02	555	13-17	11-15	4-8			20
	7	.02	500	12-16	10-14	3-7			20
	8	.02	500	11-15	9-13	3-6			20
120	3	.11	1335	18-25	16-22	8-13	11 1/2	13	35
	4	.06	1000	17-24	15-20	7-13			30
	5	.04	800	16-23	14-21	6-12			25
	6	.03	665	15-21	13-19	5-11			20
	7	.02	570	14-20	12-17	4-10			20
	8	.02	500	13-19	11-16	3-9			20
	9	.02	500	12-18	10-15	3-8			20
	10	.02	500	11-17	9-14	3-7			20
140	4	.09	1165	18-25	16-21	8-15	11 1/2	14	30
	5	.05	935	18-26	16-22	8-14			30
	6	.04	780	17-25	15-22	7-14			25
	7	.03	665	16-23	14-20	6-12			20
	8	.02	585	15-20	13-20	5-10			20
	9	.02	500	14-19	12-19	4-9			20
	10	.02	500	13-18	11-18	3-8			20
	11	.02	500	12-17	10-17	3-7			20
160	4	.11	1335	19-27	17-24	10-16	12	15	35
	5	.07	1065	18-26	16-23	8-15			30
	6	.05	890	17-25	15-22	7-14			25
	7	.04	760	16-23	14-20	6-12			25
	8	.03	665	15-20	13-18	5-10			20
	9	.02	590	14-19	12-17	4-9			20
	10	.02	500	13-18	11-17	3-8			20
	11	.02	500	12-17	10-16	3-7			20
	12	.02	500	11-16	9-15	3-6			20
180	5	.09	1200	20-30	18-27	10-19	12	15	35
	6	.06	1000	19-28	17-25	9-17			30
	7	.05	850	18-26	16-23	8-15			25
	8	.04	750	16-24	14-21	6-13			20
	9	.03	665	15-21	13-19	5-11			20
	10	.02	600	14-19	12-18	4-10			20
	11	.02	500	13-18	11-17	3-9			20
	12	.02	500	12-17	10-16	3-8			20
	13	.02	500	11-16	9-15	3-7			20
	14	.02	500	10-15	8-14	3-6			20
200	5	.11	1335	23-33	20-30	12-21	12	5	35
	6	.08	1110	21-32	19-29	10-20			30
	7	.06	950	20-31	18-27	9-18			30
	8	.04	835	18-27	16-24	8-16			25
	9	.03	740	17-26	15-23	6-14			20
250	6	.12	1390	24-35	21-31	-	13	15	35
	7	.09	1190	23-34	20-30	-			35
	8	.07	1040	21-32	19-28	-			30
	9	.05	925	20-31	18-27	-			25
	10	.04	833	19-30	17-26	-			25
300	7	.13	1430	25-40	23-35	-	13	16	35
	8	.10	1250	24-36	22-32	-			35
	9	.08	1110	23-34	20-30	-			30
	10	.06	1000	22-32	19-28	-			30
	11	.06	1000	21-31	18-27	-			30
350	8	.13	1460	27-47	24-43	-	14	16	40
	9	.11	1300	26-45	23-41	-			35
	10	.09	1165	25-42	22-39	-			35
	11	.09	1165	24-41	21-38	-			30



DATA SHEET

272

9 and 10 slots not available

ENGINEERING PERFORMANCE DATA



ALS17 1" SLOT SUPPLY DIFFUSER

NOTES:

- Table 1 based on 4 ft. diffuser length. For longer lengths, correct throw and NC per Table 2.
- For 2-way ceiling throw, proportion (CFM) and number of slots in each direction of T and select from 1-way data, Table 1.
- When using continuous diffuser lengths with alternating active and inactive sections, a reduction in throw can be obtained by omitting the factors contained in Table 2.
- P_s constant for horizontal 1-way, 2-way and vertical pattern adjustment.
- Supply air temperature effect on horizontal throw is shown in Table 3. Vertical throw at varying supply air temperatures is shown in Table 4.
- Terminal velocities (V_T) at the minimum and maximum Throw (T) positions are rated at 150 FPM and 100 FPM respectively with corresponding room velocities (V_R) of 50 FPM and 35 FPM.

TABLE 2 CONTINUOUS DIFFUSER LENGTH FACTORS

Modify Table 1 by factors for diffuser lengths above 4ft.				
Diffuser Length	Throw (T)			NC
	Ceiling Min.-Max.	Sidewall Min.-Max.	Sill Min.-Max.	
4' - 6'	No Change			+ 0
7' - 20'	T x 1.10			+ 5
21' - 100'	T x 1.15			+ 10

TABLE 4 VERTICAL DOWN-THROW and Supply Temperature Factors

Multiply Throw-Sidewall in Table 1 (or factor in Table 2 if used) by listed value.			
	@ - 11°C ΔT	@ 0°C ΔT	@ + 14°C ΔT
	@ - 20F ΔT	@ 0F ΔT	@ + 25F ΔT
	Cooling	Ventilating	Heating
Case 1	T x 1.0	T x .90	T x .60
Case 2	T x .70	T x .60	T x .40

TABLE 5 SUPPLY DIFFUSERS AREAS Per Ft. of Length

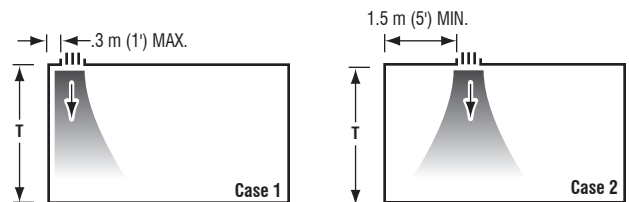
	No. of Slots							
	1	2	3	4	5	6	7	8
A_N Area	.04	.06	.09	.12	.15	.18	.21	.24
	.17	.33	.50	.67	.83	1.00	1.17	1.33

A_K constant for horizontal 1-way, 2-way and vertical pattern.

$$CFM = A_K \times \text{length in feet} \times V_K$$

TABLE 3 SUPPLY AIR TEMPERATURE FACTORS

Multiply Throw in Table 1 (or factor in Table 2 if used) by listed value.			
Ceiling Sidewall Sill	@ - 11°C ΔT	@ 0°C ΔT	@ + 14°C ΔT
	@ - 20F ΔT	@ 0F ΔT	@ + 25F ΔT
	T x 1.0	T x 1.1	T x 1.2



AIR MEASUREMENT		
Supply Horizontal	Supply Vertical	Return Air
6070 VELOMETER JET FOR V_K VELOCITY		

ENGINEERING PERFORMANCE DATA

ALS10 1" SLOT RETURN



TABLE 1 RETURN AIR CFM PER FOOT OF LENGTH

No. of Slots	A _K Area	NC 20-25 Application Non-Ducted		NC 30 Application Ducted		NC 35-40 Application Ducted	
		- .02" P _s	- .03" P _s	- .08" P _s	- .10" P _s	- .15" P _s	- .20" P _s
		CFM	CFM	CFM	CFM	CFM	CFM
1	.06	35	43	70	80	95	110
2	.11	70	85	140	155	190	220
3	.17	105	130	210	235	285	330
4	.23	140	170	280	310	380	440
5	.28	175	215	350	390	475	550
6	.33	210	255	420	465	570	660
7	.39	245	300	490	545	665	770
8	.44	280	340	560	620	760	880

Capacity based on diffuser without pattern controller. When pattern controller is used CFM capacities are reduced by 65% at listed P_s, NC and A_K.

ENGINEERING PERFORMANCE DATA

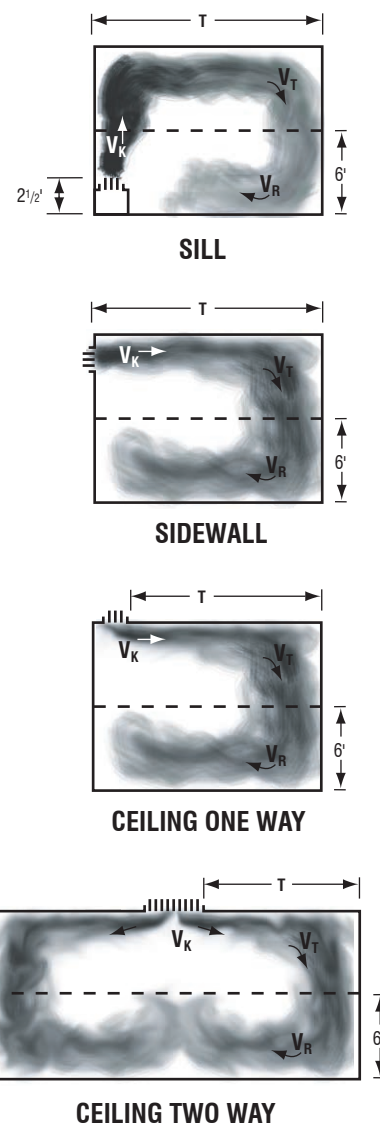
ALS27 1/2" SUPPLY SLOT DIFFUSER



TABLE 1 SUPPLY AIR

CFM per Foot in Direction of T	No. of Slots	Min. P _s In. H ₂ O	Outlet Velocity (V _k) FPM	Throw (T) in Feet			Minimum Ceiling Height in Feet		NC		
				Ceiling	Sidewall	Sill	in Feet				
				Min.-Max.	Min.-Max.	Min.-Max.	@ -18F ΔT	@ -25F ΔT			
10	1	.02	500	5-7	3-5	1-2	7 1/2	9	<20		
	2		335							4-6	2-4
20	1	.08	1000	10-13	8-11	1-3	8	9	20		
	2	.02	670	8-11	6-9	2-3			<20		
	3	.01	400	6-9	4-7	1-2			<20		
30	1	.18	1500	11-16	10-14	4-6	9	10	25		
	2	.05	1000	10-14	8-12	3-4			20		
	3	.02	600	8-11	6-9	2-3			<20		
	4	.01	430	7-9	5-7	1-2			<20		
40	2	.08	1330	13-17	11-15	4-6	9	11	25		
	3	.04	800	10-14	8-12	3-5			20		
	4	.02	570	9-12	7-10	2-3			20		
	5	.01	445	8-11	6-9	2-3			<20		
	3	.06	1000	11-15	9-13	4-6			9 1/2	11	25
4	.03	710	10-14	8-12	3-4	20					
5	.02	560	9-13	7-11	2-4	20					
6	.01	500	8-12	7-10	1-3	<20					
60	3	.08	1200	13-17	11-15	5-8	9 1/2	12	25		
	4	.05	855	12-16	10-14	4-7			25		
	5	.03	670	11-15	9-13	3-6			20		
	6	.02	600	10-14	8-12	3-5			<20		
	7	.01	500	9-13	7-11	2-4			<20		
	3	.12	1400	15-20	13-18	6-11			10	12	25
	4	.06	1000	13-18	11-16	5-9					25
5	.04	780	12-16	10-14	4-7	20					
6	.03	700	11-15	9-13	3-6	20					
70	7	.02	580	10-15	8-13	2-5			20		
	4	.08	1140	14-20	12-18	6-11	10 1/2	12 1/2	25		
	5	.05	890	13-19	11-17	5-10			25		
	6	.04	800	13-18	11-16	5-9			25		
	7	.03	670	13-17	11-15	4-8			20		
	8	.02	570	12-16	10-14	3-7			20		
	4	.10	1280	17-24	15-21	8-14			11	13	30
	5	.07	1000	16-22	14-20	7-13					25
6	.05	900	16-21	14-19	7-12	25					
7	.04	750	15-20	13-18	6-11	25					
8	.03	640	14-18	12-16	5-9	20					
9	.02	600	13-17	11-15	4-8	20					
5	.09	1120	18-25	16-22	9-15	11	13	25			
6	.06	1000	17-24	15-21	8-14			25			
7	.05	830	16-23	14-20	7-13			25			
8	.03	710	14-20	12-18	6-11			20			
9	.03	670	13-19	11-17	5-10			20			
10	.02	590	12-18	10-16	5-10			<20			
120	6	.09	1200	19-27	17-24	10-16	11 1/2	13	30		
	7	.07	1000	18-26	16-23	8-15			25		
	8	.05	860	17-25	15-22	7-14			25		
	9	.04	800	16-24	14-21	6-13			20		
	10	.03	705	15-22	13-19	5-11			20		
140	7	.10	1170	20-30	18-27	10-19	11 1/2	14	25		
	8	.06	1000	19-28	17-25	9-17			25		
	9	.05	930	18-27	16-24	8-16			20		
	10	.04	825	17-25	15-22	7-14			20		
160	8	.08	1140	21-32	19-29	10-20	12	15	25		
	9	.07	1070	20-30	18-27	9-18			25		
	10	.05	940	19-28	17-25	8-17			20		
180	8	.08	1280	24-35	21-31	12-22	12	15	30		
	9	.07	1200	23-34	20-30	11-21			25		
	10	.05	1060	22-32	19-29	10-20			25		
200	9	.10	1335	25-39	22-35	-	12	15	30		
	10	.08	1175	24-37	21-33	-			25		

9 and 10 slots not available



Outlet Velocity (V _k) FPM										
500	600	700	800	900	1000	1200	1400	1600	1800	2000
Total Pressure (P _t) Inches H ₂ O										
.02	.02	.03	.04	.05	.06	.09	.12	.16	.20	.25

- SYMBOLS
- V_T Terminal Velocity in FPM
 - V_R Room Velocity in FPM
 - V_K Outlet Velocity in FPM
 - A_K Outlet area in Sq. Feet
 - A_N Neck Area in Sq. Ft.
 - P_s Static Pressure H₂O
 - NC Re 8db Room attenuation
 - T Throw in feet at X and Y
 - ΔT Temperature Differential

ENGINEERING PERFORMANCE DATA



ALS27 1/2" SLOT SUPPLY DIFFUSER

NOTES:

- Table 1 based on 4 ft. diffuser length. For longer lengths, correct throw and NC per Table 2.
- For 2-way ceiling throw, proportion (CFM) and number of slots in each direction of T and select from 1-way data, Table 1.
- When using continuous diffuser lengths with alternating active and inactive sections, a reduction in throw can be obtained by omitting the factors contained in Table 2.
- P_S constant for horizontal 1-way, 2-way and vertical pattern adjustment.
- Supply air temperature effect on horizontal throw is shown in Table 3. Vertical throw at varying supply air temperatures is shown in Table 4.
- Terminal velocities (V_T) at the minimum and maximum Throw (T) positions are rated at 150 FPM and 100 FPM respectively with corresponding room velocities (V_R) of 50 fpm and 35 FPM.

TABLE 2 CONTINUOUS DIFFUSER LENGTH FACTORS

Modify Table 1 by factors for diffuser lengths above 4ft.				
Diffuser Length	Throw (T)			NC
	Ceiling Min.-Max.	Sidewall Min.-Max.	Sill Min.-Max.	
4' - 6'	No Change			+ 0
7' - 20'	T x 1.10			+ 5
21' - 100'	T x 1.15			+ 10

TABLE 4 VERTICAL DOWN-THROW and Supply Temperature Factors

Multiply Throw-Sidewall in Table 1 (or factor in Table 2 if used) by listed value.			
	@ - 11°C ΔT	@ 0°C ΔT	@ +14°C ΔT
	@ - 20F ΔT	@ 0F ΔT	@ +25F ΔT
	Cooling	Ventilating	Heating
Case 1	T x 1.0	T x .90	T x .60
Case 2	T x .70	T x .60	T x .40

TABLE 5 SUPPLY DIFFUSERS AREAS Per Ft. of Length

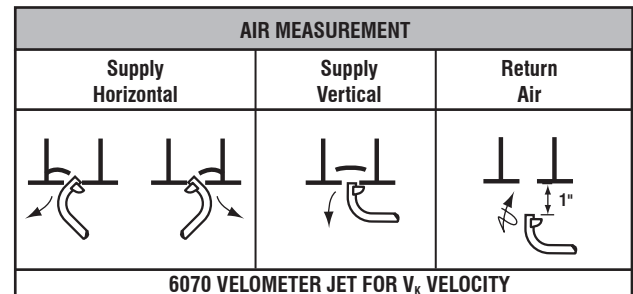
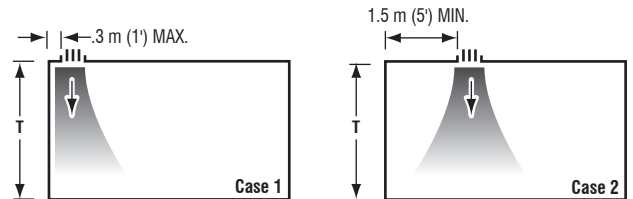
	No. of Slots							
	1	2	3	4	5	6	7	8
A_N Area	.02	.03	.05	.07	.09	.10	.12	.14
A_K Area	.08	.17	.25	.33	.42	.50	.58	.67

A_K constant for horizontal 1-way, 2-way and vertical pattern.

$$CFM = A_K \times \text{length in feet} \times V_K$$

TABLE 3 SUPPLY AIR TEMPERATURE FACTORS

Multiply Throw in Table 1 (or factor in Table 2 if used) by listed value.			
Ceiling Sidewall Sill	@ - 11°C ΔT	@ 0°C ΔT	@ +14°C ΔT
	@ - 20F ΔT	@ 0F ΔT	@ +25F ΔT
	T x 1.0	T x 1.1	T x 1.2



ENGINEERING PERFORMANCE DATA

ALS20 1/2" SLOT RETURN



TABLE 1 RETURN AIR CFM Per Foot of Length

No. of Slots	A _K Area	NC 20-25		NC 30		NC 35-40	
		Application Non-Ducted		Application Ducted		Application Ducted	
		- .02" P _S CFM	- .03" P _S CFM	- .08" P _S CFM	- .10" P _S CFM	- .15" P _S CFM	- .20" P _S CFM
1	.03	15	20	30	35	40	45
2	.06	35	45	70	80	95	110
3	.08	55	70	110	125	150	175
4	.11	70	85	140	155	190	220
5	.14	90	110	180	200	245	285
6	.16	110	135	220	245	300	345
7	.20	130	160	260	290	355	410
8	.22	140	170	280	310	385	440

Capacity based on diffuser without pattern controller. When pattern controller is used CFM capacities are reduced by 65% at listed P_S, NC and A_K.

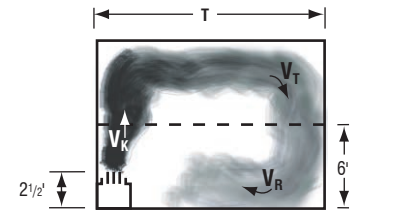
ENGINEERING PERFORMANCE DATA

ALS37 3/4" SUPPLY SLOT DIFFUSER

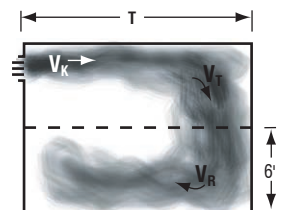


TABLE 1 SUPPLY AIR

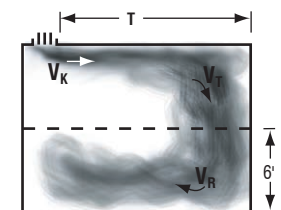
CFM per Foot in Direction of T	No. of Slots	Min. P _s In. H ₂ O	Outlet Velocity (V _k) FPM	Throw (T) in Feet			Minimum Ceiling Height in Feet		NC			
				Ceiling	Sidewall	Sill	Minimum Ceiling Height in Feet					
				Min.-Max.	Min.-Max.	Min.-Max.	@ -18F ΔT	@ -25F ΔT				
10	1	.01	335	4-6	2-4	1-2	7 1/2	9	<20			
20	1	.04	670	8-11	6-9	2-3	8	9	20			
	2	<.01	400	6-9	4-7	1-2			<20			
30	1	.09	1000	10-14	8-12	3-4	9	10	25			
	2	.02	600	8-11	6-9	2-3			20			
	3	<.01	430	7-9	5-7	1-2			<20			
40	1	.16	1340	13-7	11-15	4-6	9	11	30			
	2	.04	800	10-14	8-12	3-4			25			
	3	.02	575	9-12	7-10	2-3			20			
	4	.01	445	8-11	6-9	2-3			<20			
50	2	.06	1000	11-15	9-13	4-6	9 1/2	11	25			
	3	.03	715	10-14	8-12	3-4			20			
	4	.02	555	9-13	7-11	2-3			<20			
	5	<.01	415	7-12	6-10	2-3			<20			
	6	.09	1200	13-17	11-15	5-8			9 1/2	12	30	
3	.04	860	12-16	10-14	4-7	25						
4	.02	665	11-15	9-13	3-6	20						
5	.01	500	9-13	7-11	3-4	<20						
70	2	.13	1400	15-20	13-18	6-11	10	12			30	
	3	.06	1000	13-18	11-16	5-9			25			
	4	.03	775	12-16	10-14	4-7			20			
	5	.02	585	10-15	8-13	3-5			<20			
	6	.01	500	9-14	7-12	2-5			<20			
	80	3	.07	1140	14-20	12-18			6-11	10 1/2	12 1/2	30
4		.04	885	13-19	11-17	5-10	25					
5		.03	665	13-17	11-15	4-8	20					
6		.02	575	12-16	10-14	3-7	<20					
7		<.01	500	11-15	9-13	3-6	<20					
90		3	.09	1290	17-24	15-21	8-14	11	13			30
		4	.05	1000	16-22	14-20	7-13					25
	5	.03	750	15-20	13-18	6-11	20					
	6	.02	645	14-18	12-16	5-9	<20					
	7	.01	560	13-17	11-15	4-8	<20					
	100	3	.13	1430	19-26	17-23	10-16			11	13	30
		4	.06	1110	18-25	16-22	9-15					25
5		.04	830	16-23	14-20	7-13	20					
6		.03	715	14-20	12-18	6-11	20					
7		.02	630	13-19	11-17	5-10	<20					
120		4	.09	1330	19-27	17-24	10-16	11 1/2	13			35
		5	.06	1000	18-26	16-23	8-15					30
	6	.04	860	17-25	15-22	7-14	25					
	7	.03	750	16-23	14-20	6-12	20					
	8	.02	630	15-20	13-18	5-10	<20					
	140	5	.08	1170	20-30	18-27	10-19			11 1/2	14	30
		6	.06	1000	19-28	17-25	9-17					25
		7	.04	875	18-26	16-23	8-15					20
8		.03	740	16-24	14-21	6-13	20					
9		.02	665	15-21	13-19	5-11	<20					
160	6	.07	1150	21-32	19-29	10-20	12	15	25			
	7	.05	1000	20-30	18-27	9-18			25			
	8	.04	840	18-27	16-24	8-16			20			
	9	.03	760	17-26	15-23	6-14			<20			
	10	.02	695	16-25	14-22	5-13			<20			
180	6	.09	1290	24-35	21-31	12-22	12	15	30			
	7	.07	1130	23-34	20-30	11-21			30			
	8	.05	950	20-31	18-28	9-19			25			
	9	.04	860	19-30	17-27	8-18			20			
	10	.03	780	18-29	16-26	7-17			<20			
200	6	.11	1440	26-40	23-36	-	12	15	30			
	7	.08	1250	25-38	22-34	-			30			
	8	.06	1110	24-36	21-32	-			25			
	9	.05	955	22-33	20-30	-			25			
	10	.04	870	21-31	19-28	-			20			
250	8	.10	1315	26-46	23-41	-	13	15	35			
	9	.07	1190	25-42	22-38	-			30			
	10	.06	1085	24-39	21-35	-			25			



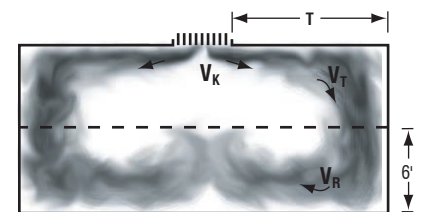
SILL



SIDEWALL



CEILING ONE WAY



CEILING TWO WAY

Outlet Velocity (V _k) FPM										
500	600	700	800	900	1000	1200	1400	1600	1800	2000
Total Pressure (P _T) Inches H ₂ O										
.02	.02	.03	.04	.05	.06	.09	.12	.16	.20	.25

- SYMBOLS
- V_T Terminal Velocity in FPM
 - V_R Room Velocity in FPM
 - V_K Outlet Velocity in FPM
 - A_K Outlet area in Sq. Feet
 - A_N Neck Area in Sq. Ft.
 - P_S Static Pressure H₂O
 - NC Re 8db Room attenuation
 - T Throw in feet at X and Y
 - ΔT Temperature Differential

DATA SHEET

278

ENGINEERING PERFORMANCE DATA

ALS37 3/4" SLOT SUPPLY DIFFUSER



NOTES:

- Table 1 based on 4 ft. diffuser length. For longer lengths, correct throw and NC per Table 2.
- For 2-way ceiling throw, proportion (CFM) and number of slots in each direction of T and select from 1-way data, Table 1.
- When using continuous diffuser lengths with alternating active and inactive sections, a reduction in throw can be obtained by omitting the factors contained in Table 2.
- P_s constant for horizontal 1-way, 2-way and vertical pattern adjustment.
- Supply air temperature effect on horizontal throw is shown in Table 3. Vertical throw at varying supply air temperatures is shown in Table 4.
- Terminal velocities (V_T) at the minimum and maximum Throw (T) positions are rated at 150 FPM and 100 FPM respectively with corresponding room velocities (V_R) of 50 fpm and 35 FPM.

TABLE 2 CONTINUOUS DIFFUSER LENGTH FACTORS

Modify Table 1 by factors for diffuser lengths above 4ft.				
Diffuser Length	Throw (T)			NC
	Ceiling Min.-Max.	Sidewall Min.-Max.	Sill Min.-Max.	
4' - 6'	No Change			+ 0
7' - 20'	T x 1.10			+ 5
21' - 100'	T x 1.15			+ 10

TABLE 3 SUPPLY AIR TEMPERATURE FACTORS

Multiply Throw in Table 1 (or factor in Table 2 if used) by listed value.			
Ceiling Sidewall Sill	@ - 11°C ΔT	@ 0°C ΔT	@ +14°C ΔT
	@ - 20F ΔT	@ 0F ΔT	@ +25F ΔT
	T x 1.0	T x 1.1	T x 1.2

TABLE 4 VERTICAL DOWN-THROW and Supply Temperature Factors

Multiply Throw-Sidewall in Table 1 (or factor in Table 2 if used) by listed value.			
	@ - 11°C ΔT	@ 0°C ΔT	@ +14°C ΔT
	@ - 20F ΔT	@ 0F ΔT	@ +25F ΔT
	Cooling	Ventilating	Heating
Case 1	T x 1.0	T x .90	T x .60
Case 2	T x .70	T x .60	T x .40

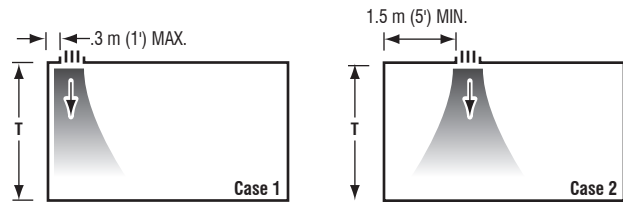


TABLE 5 SUPPLY DIFFUSERS AREAS Per Ft. of Length

	No. of Slots							
	1	2	3	4	5	6	7	8
A_N Area	.03	.05	.07	.09	.12	.14	.16	.19
A_K Area	.12	.24	.36	.48	.60	.72	.84	.96

A_K constant for horizontal 1-way, 2-way and vertical pattern.

$$CFM = A_K \times \text{length in feet} \times V_K$$

AIR MEASUREMENT		
Supply Horizontal	Supply Vertical	Return Air
6070 VELOMETER JET FOR V_K VELOCITY		

ALS30 3/4" SLOT RETURN



TABLE 1 RETURN AIR CFM Per Foot of Length

No. of Slots	A _K Area	NC 20-25		NC 30		NC 35-40	
		Application Non-Ducted		Application Ducted		Application Ducted	
		- .02" P _S CFM	- .03" P _S CFM	- .08" P _S CFM	- .10" P _S CFM	- .15" P _S CFM	- .20" P _S CFM
1	.04	25	35	50	65	75	90
2	.08	50	60	100	110	135	160
3	.12	80	100	160	180	220	250
4	.16	100	120	200	225	275	320
5	.20	130	160	260	295	360	420
6	.24	160	195	320	360	440	510
7	.28	175	215	350	390	475	550
8	.32	200	245	400	445	545	630

Capacity based on diffuser without pattern controller. When pattern controller is used CFM capacities are reduced by 65% at listed P_S, NC and A_K.

HOW TO SPECIFY ARCHITECTURAL LINEAR SLOT DIFFUSERS

Supply Diffuser

Supply and mounting of linear slot diffuser with uniflex pattern and volume controller, series **ALS**. Constructed from powder coater extruded aluminum with 45 degree mitered corners, manufactured by Airvector.

Return

Supply and mounting of linear slot return, series **ALS**. Constructed from powder coater extruded aluminum with 45 degree mitered corners, manufactured by Airvector.

ALZ & ALZ-BX SERIES Flush Surface-Matching

A Modern, Linear Register That Disappears Into Your Floor

The Airvector® **ALZ** & **ALZ-BX** Series offers two modern, flush-mounted registers engineered to deliver high-performance airflow while blending invisibly into your flooring. Whether you need a linear grille that matches your surface material or a model optimized for perimeteric air diffusion, the **ALZ** & **ALZ-BX** Series provides minimalist elegance without compromising on functionality.

ALZ – Flush Surface-Matching

The **ALZ** model is designed to disappear into your floor while providing clean, directional airflow. Its U-shaped bars are spaced at 3/8", with a thickness of 5/8", allowing for the insertion of wood, tile, or other floor materials for a fully integrated finish. The result: a seamless, ultra-discreet register that looks like part of your floor.

- Flush mount design for uninterrupted flooring.
- Accepts flooring inserts between U-shaped steel bars.
- Optimized airflow slots ensure effective performance.
- Designed to accommodate 2 bars for 2" width, 3 bars for 3", etc.

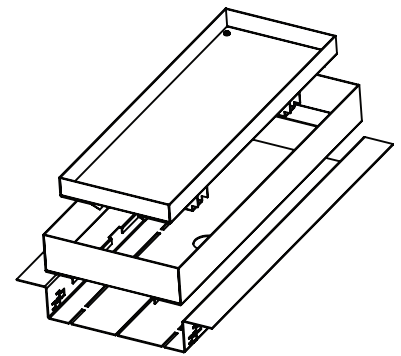
ALZ-BX – Flush Register with Perimeteric Airflow Channel

The **ALZ-BX** shares the same minimalist flush look but diffuses air through a hidden perimeteric channel around the insert tray, maintaining a clean aesthetic with quiet, efficient airflow.

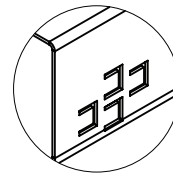
- Perimeteric air distribution for a fully concealed appearance.
- Integrated airflow damper for volume and direction control.

KEY FEATURES – ALZ & ALZ-BX

- Flush mount design for uninterrupted, surface-level integration
- Durable solid steel construction with a powder-coated finish.
- Surface-matching compatibility: accepts wood, tile, vinyl, or carpet inserts (7/8, 3/4, 5/8 or 1/2 thick)
- HVAC compatible and easy to clean.
- Child- and pet-safe design prevents small object intrusion
- Available in multiple sizes to suit various floor openings
- Made for professionals and refined interior projects.



ALZ-BX



OPTIONS

- Compatible with wood, tile, carpet, or vinyl inserts (7/8, 3/4, 5/8 or 1/2 thick) and available in multiple sizes to fit a wide range of floor openings.
- Custom powder-coated finishes for colors for seamless architectural integration and durability.

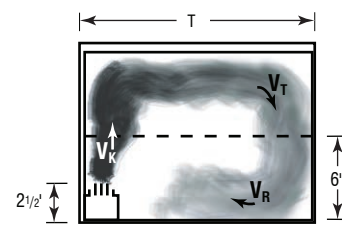
Flush-Mount Surface-Matching Register ALZ

CFM per Foot in Direction of T	long.	Min. P_s In. H_2O	Outlet Velocity (V_k) FPM	Throw (T) in Feet	NC
10	1' - 6' 7' - 20' 21' - 100'	<.01	335	- 1.10-2.20 1.15-2.30	<20 25 30
20	1' - 6' 7' - 20' 21' - 100'	.02	670	- 2.20-3.30 2.30-3.45	<20 25 30
30	1' - 6' 7' - 20' 21' - 100'	.05	1000	- 3.30-4.40 3.45-4.60	20 25 30
40	1' - 6' 7' - 20' 21' - 100'	.08	1330	- 4.40-6.60 4.60-6.90	25 30 40

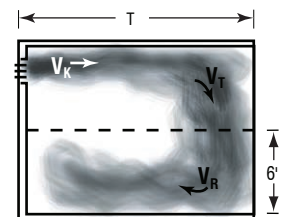
SYMBOLS V_k Outlet Velocity in FPM
 P_s Static Pressure H_2O
 NC Noise Criteria, Re 8db Room attenuation
 T Throw in feet at X and Y

Data based on test results according to ASHRAE Standard 70-06.

Outlet Velocity (V_k) FPM												
500	600	700	800	900	1000	1200	1400	1600	1800	2000		
Total Pressure (P_T) Inches H_2O												
.02	.02	.03	.04	.05	.06	.09	.12	.16	.20	.25		



SILL



SIDEWALL

ARCHITECTURAL GRILLES



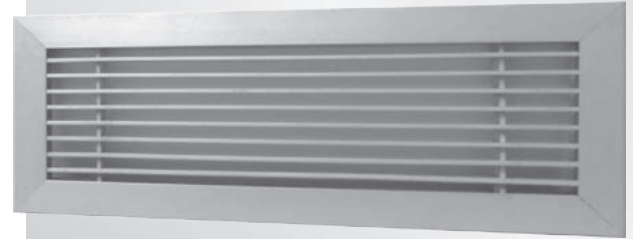
ARCH SERIES Architectural Sidewall Linear Bar Grilles and Registers

Series ARCH - Architectural Sidewall Linear Bar Grilles are designed for installation in the sidewall and are recommended for supplying heated, ventilated, or cooled air, and for returning or exhausting room air. Series ARCH provide a slick look, extreme durability, quick installation and easy access to duct for cleaning and maintenance. All those features combined are what make Series ARCH a best value option for high end residential and commercial applications.

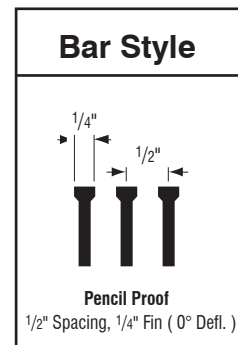
Offered in various finishes to suit all applications, Series ARCH feature a concealed fastening method with no apparent screw holes for a better look. Frame is secured with hidden screw holes in the neck. Removable core is held firmly with sturdy spring clips to avoid any rattling. The Pencil Proof bar style (1/4" bar, 1/2" center-to-center spacing) offers a 50% free area for an optimized balance between aesthetic, security and performance.

Their reliable performance assures confident use of cooling temperature differentials up to 25°F at predicted low air motion of 35 fpm in the zone of occupancy. Series ARCH Grilles perform efficiently with air loadings of 1 to 2 1/2 CFM per sq.ft. and a sound level range of NC 25 to 35. When installed in the sidewall near the ceiling, Series ARCH Grilles provide a horizontal pattern above the occupied zone.

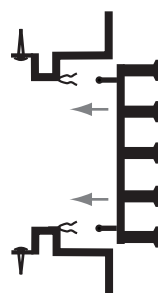
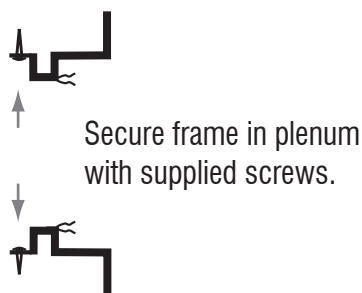
Series ARCH Grilles are fabricated of high-quality aluminum extrusions. Components are mechanically interlocked for a blemish-free appearance. Opposable Blade Volume dampers are integrally fastened to ARCH7 Registers.



ARCH

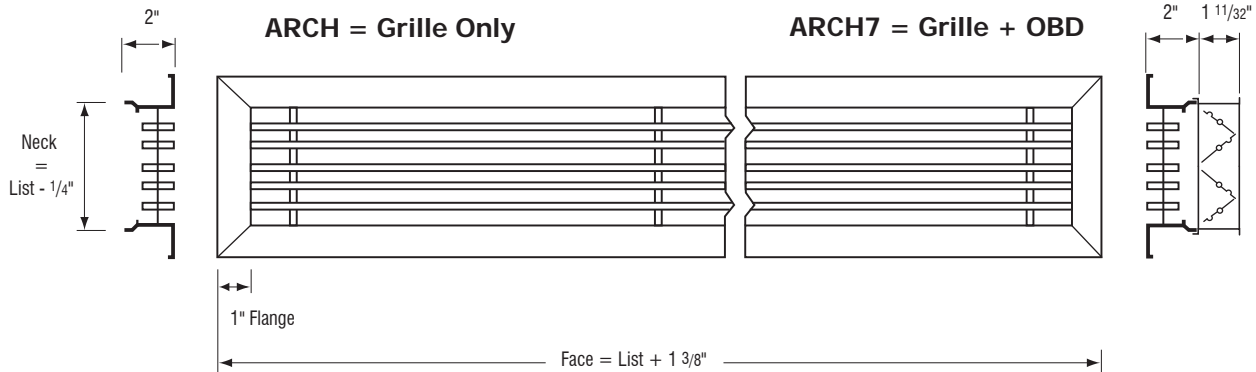


Concealed Screw Holes & Removable Core with Spring Clips - Two Steps Installation



ARCHITECTURAL STYLES

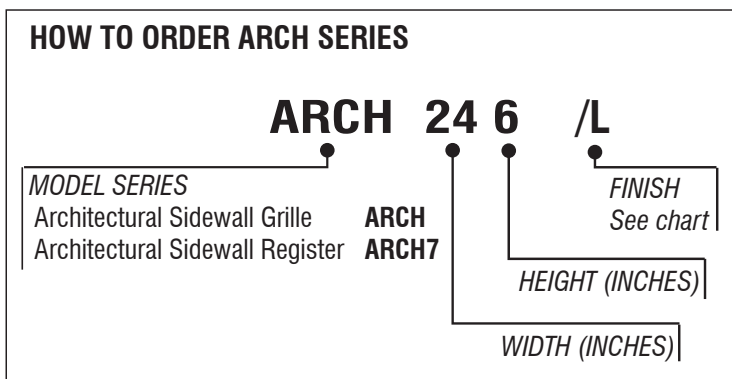
ARCH SERIES



All dimensions in inches.
 Series ARCH products include a 1/32" tolerance for thermal expansion based on a +40°F temperature differential.
 For every +20°F differential above +40°F, reduce required listed length by 1/64" per 5 feet of length.

How to Specify ARCH Series

Supply and mounting of Airvector® Series ARCH architectural sidewall linear bar grille with concealed screw fastening and removable core with clips. Constructed from heavy gauge extruded aluminum.



ENGINEERING PERFORMANCE DATA

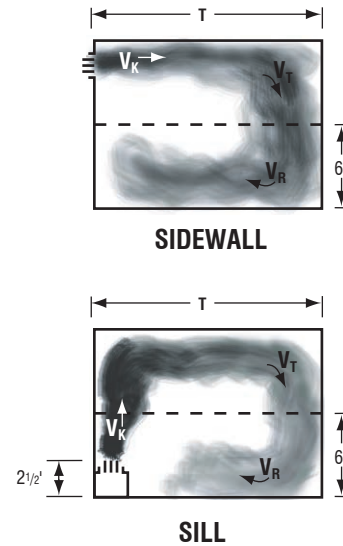
ARCH SERIES



TABLE 1 SUPPLY AIR

CFM per Foot	Listed Width in Inches	Min. P _s in H ₂ O	Outlet Velocity (V _k) FPM	Throw (T) in Feet		Minimum Ceiling Height in Feet		NC
				Sidewall Min.-Max.	Sill Min.-Max.	@-18°F ΔT	@-25°F ΔT	
60	4	.01	425	8-12	2-5	9 1/2	12	<20
70	4	.01	500	10-14	3-7	10	12	<20
80	4	.01	570	11-16	4-9	10 1/2	12 1/2	20
90	4	.02	635	13-18	6-11	11	13	25
	5	.01	520	11-16	4-9			20
100	4	.03	715	14-20	7-13	11	13	25
	5	.01	575	12-18	5-11			20
120	4	.04	855	17-24	9-16	11 1/2	13	30
	5	.03	680	15-22	7-14			25
	6	.01	550	13-19	5-11			20
140	4	.05	1000	19-28	11-20	11 1/2	14	30
	5	.03	810	17-25	9-17			25
	6	.01	645	15-22	7-14			20
160	4	.07	1140	22-32	13-23	12	15	35
	5	.04	925	19-29	10-20			30
	6	.03	735	18-26	9-17			25
	8	.01	530	15-22	6-13			20
180	4	.09	1275	25-36	16-27	12	15	35
	5	.05	1035	22-33	13-24			30
	6	.04	835	20-30	11-21			25
	8	.03	600	17-25	8-16			20
200	4	.11	1425	28-41	-	12	15	40
	5	.07	1150	24-36	-			35
	6	.05	925	23-33	-			30
	8	.03	665	20-28	-			25
250	5	.11	1440	30-46	-	13	15	40
	6	.07	1150	27-39	-			35
	8	.04	830	25-35	-			30
	10	.01	635	21-32	-			25
300	6	.09	1375	33-48	-	13	15	40
	8	.05	1000	29-42	-			35
	10	.03	765	25-39	-			30
	12	.01	630	23-33	-			25
350	8	.08	1175	34-48	-	13	15	40
	10	.04	900	29-45	-			35
	12	.03	735	26-38	-			30
400	8	.11	1350	40-55	-	14	16	45
	10	.05	1025	33-50	-			40
	12	.04	845	30-44	-			35

Terminal velocities (V_T) at the minimum and maximum Throw (T) values are rated at 125 FPM and 75 FPM respectively with corresponding room velocities (V_R) of 50 fpm and 35 FPM.



Outlet Velocity (V _k) FPM										
500	600	700	800	900	1000	1200	1400	1600	1800	2000
Total Pressure (P _T) Inches H ₂ O										
.02	.02	.03	.04	.05	.06	.09	.12	.16	.20	.25

TABLE 2 RETURN AIR (CFM Per Foot of Length)

Listed Width in Inches	A _k Area	NC 20-25 Non-Ducted		NC 25-30 Ducted		NC 30-40 Ducted	
		-.02" P _s -.03" P _s		-.08" P _s -.10" P _s		-.15" P _s -.20" P _s	
		CFM	CFM	CFM	CFM	CFM	CFM
4	.34	75	90	150	165	205	235
5	.41	95	120	190	215	260	305
6	.46	120	145	240	265	325	375
8	.57	160	200	325	360	445	515
10	.68	210	255	415	465	570	655
12	.76	255	310	510	565	695	800

- SYMBOLS
- V_T Terminal Velocity in fpm
 - V_R Room Velocity in fpm
 - V_k Outlet Velocity in fpm
 - A_k Outlet area in Sq. Feet
 - A_N Neck Area in Sq. Ft.
 - P_s Static Pressure H₂O
 - P_T Total Pressure H₂O
 - NC Re 8db Room attenuation
 - T Throw in feet at X and Y
 - ΔT Temperature Differential

ENGINEERING PERFORMANCE DATA

ARCH SERIES

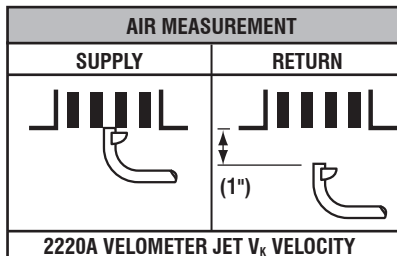


TABLE 3 SUPPLY AIR TEMPERATURE FACTORS

Multiply Throw in Table 1 (or factor in Table 2 if used) by listed value.			
Sidewall Sill	@-20°F ΔT T x 1.10	@ 0°F ΔT T x 1.11	@+25°F ΔT T x 1.12

TABLE 4 SUPPLY GRILLES AREAS Per Ft. of Length

		Listed Width in inches																
		1.5"	2"	2.5"	3"	4"	5"	6"	8"	10"	12"	14"	16"	18"	20"	24"	30"	36"
A_N		.13	.17	.21	.25	.33	.42	.50	.67	.84	1.0	1.2	1.3	1.5	1.7	2.0	2.5	3.0
A_K		.04	.06	.09	.11	.16	.20	.25	.35	.45	.55	.68	.79	.90	1.0	1.3	1.6	2.1
A_K		.03	.05	.08	.09	.14	.17	.21	.30	.38	.47	.58	.67	.77	.85	1.1	1.4	1.8



NOTES:

1. ΔP_s static pressure difference inlet to discharge.
2. ΔP_s is the minimum pressure required to deliver CFM shown with the primary damper in wide open position.
3. ΔP_t is the total pressure difference from inlet to discharge.
4. NC level less than 10 shown as (-).

- a) 5 foot lined flex duct (8" diameter).
- b) 5 foot rectangular duct lined with 1" fiberglass insulation.
- c) Space effect factor (2400 ft³) at 5 feet from outlet.
- d) End reflection.
- e) Flow division.

Radiated NC levels are based on :

- a) Plenum / ceiling effect - 5/8" mineral fiber tile, 35 lb / ft³ - 3 foot plenum.
- b) Environmental adjustment factor.

NC levels are derived from tests conducted in accordance with AHRI Standard 880-2008 and are calculated in accordance with AHRI Standard 885-2008 as application data based on the following:

*Not in the AHRI 880 Certification Program.

Inlet Size Inches)	CFM per Foot	Min. ΔP_s (Damper Full Open)				1.0" ΔP_s			1.5" ΔP_s			3.0" ΔP_s		
		Min. ΔP_s	ΔP_t	Disch. NC	Rad. NC	ΔP_t	Disch. NC	Rad. NC	ΔP_t	Disch. NC	Rad. NC	ΔP_t	Disch. NC	Rad. NC
		Basic Units												
5	75	.03	.05	-	-	1.02	-	-	1.52	-	13	3.020	13	20
	100	.05	.09	-	-	1.04	-	11	1.54	10	13	3.035	13	20
	200	.19	.33	-	-	1.14	19	19	1.64	22	22	3.142	25	24
	300	.43	.75	13	19	1.32	28	24	1.82	30	28	3.319	33	30
	350	.43	.99	14	22	1.44	28	27	1.94	30	28	3.435	34	32
6	110	.02	.04	-	-	1.02	-	13	1.52	-	17	3.020	14	24
	200	.07	.14	-	-	1.06	16	19	1.56	18	19	3.064	21	25
	300	.15	.29	-	-	1.14	20	22	1.64	24	24	3.144	30	26
	400	.27	.53	-	13	1.26	22	22	1.76	24	26	3.256	34	31
	500	.40	.80	15	19	1.40	26	27	1.94	27	28	3.400	35	33
7	140	.01	.03	-	-	1.02	-	10	1.52	-	13	3.017	15	20
	200	.02	.06	-	-	1.03	14	13	1.53	16	16	3.034	19	20
	400	.09	.23	-	-	1.14	18	20	1.64	23	23	3.136	34	31
	600	.21	.51	-	15	1.31	26	27	1.81	26	30	3.306	34	34
	700	.26	.67	-	18	1.42	22	30	1.92	26	31	3.416	33	35
8	185	.01	.03	-	-	1.02	10	14	1.52	11	15	3.018	17	20
	400	.04	.11	-	-	1.07	17	19	1.57	21	24	3.073	27	31
	600	.08	.25	-	-	1.16	19	23	1.66	25	27	3.164	35	36
	800	.14	.43	-	13	1.29	22	25	1.80	27	30	3.291	36	37
	1000	.21	.67	11	20	1.46	25	28	1.96	29	32	3.455	36	38
10	300	.01	.02	-	-	1.02	15	20	1.52	16	22	3.016	21	25
	500	.01	.06	-	-	1.05	17	21	1.54	24	27	3.045	28	34
	800	.02	.14	-	-	1.11	17	23	1.61	23	27	3.114	34	38
	1200	.05	.30	-	15	1.26	24	30	1.76	28	31	3.257	33	36
	1500	.07	.47	10	22	1.40	28	31	1.90	31	35	3.401	36	39
12	430	-	.02	-	-	1.02	17	22	1.52	19	25	3.015	22	28
	800	-	.06	-	-	1.05	15	23	1.55	23	28	3.053	34	36
	1200	.01	.13	-	-	1.12	18	24	1.62	22	28	3.119	34	36
	1800	.01	.27	-	23	1.27	22	27	1.77	27	32	3.269	34	37
	2300	.02	.45	14	31	1.44	25	30	1.94	29	33	3.439	36	40
14	600	.004	.02	-	-	1.02	17	20	1.52	23	24	3.017	28	31
	1000	.006	.05	-	-	1.05	17	22	1.55	24	27	3.046	35	35
	1600	.011	.13	-	10	1.12	19	22	1.62	24	27	3.118	35	35
	2400	.024	.29	10	25	1.27	27	30	1.76	28	35	3.265	35	38
	3100	.036	.48	21	32	1.44	31	35	1.94	34	35	3.442	38	39
16	780	.01	.02	-	-	1.02	16	21	1.57	19	25	3.018	23	43
	1600	.02	.08	-	-	1.07	17	21	1.57	22	27	3.066	35	28
	2400	.04	.19	-	19	1.15	22	28	1.65	25	31	3.148	35	37
	3600	.09	.42	24	30	1.33	31	30	1.83	25	35	3.333	37	36
	4200	.12	.57	25	35	1.45	35	36	1.95	37	36	3.453	41	43
18	1100	-	.02	-	-	1.02	16	22	1.51	19	24	3.014	25	32
	2300	.01	.07	-	-	1.06	21	27	1.56	28	30	3.063	36	39
	3600	.02	.18	16	35	1.16	25	31	1.65	30	35	3.155	38	41
	4500	.04	.28	22	38	1.24	31	39	1.74	34	40	3.241	40	44
	5500	.06	.42	31	42	1.36	36	41	1.86	38	43	3.361	42	48
24	1480	-	.01	-	-	1.01	21	32	1.51	27	37	3.011	30	46
	3200	.04	.04	-	22	1.05	22	31	1.55	27	36	3.050	37	48
	4800	.04	.09	21	38	1.11	28	35	1.61	30	37	3.112	38	45
	6000	.14	.14	28	40	1.18	33	39	1.68	35	41	3.175	40	48
	7300	.20	.21	37	47	1.26	36	41	1.76	40	46	3.260	44	48

SYMBOLS:

- PT Total Pressure H2O
- PS Static Pressure H2O
- NC Re 8db Room attenuation
- Δ Differential

ROUND DIFFUSERS



MODEL DCG ADJUSTABLE ROUND DIFFUSER

MODEL DCG - Aluminum Adjustable Round Diffuser

Airvector®'s DCG Aluminum Adjustable Round Diffusers are recommended for heating, ventilating, and cooling applications. DCG diffusers provide a 360° air diffusion pattern and excellent performance in VAV systems.

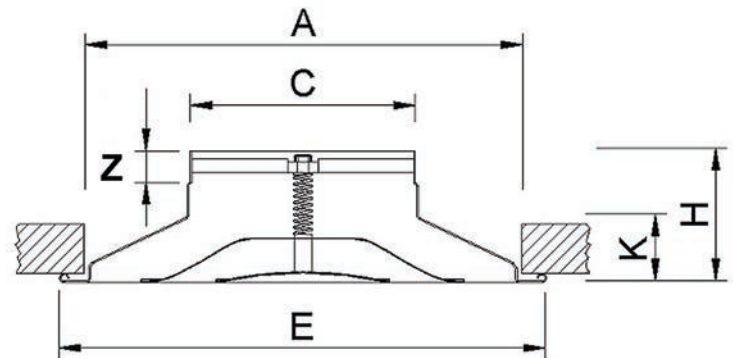
Full adjustability is possible by rotating the inner core clockwise or counterclockwise to move the cones up or down, changing from horizontal projection to vertical projection in accordance with the supply air temperature and reducing stratification. DCG diffusers provide great performance in temperatures differentials up to 54°F (12°C) and are suitable for premises with ceilings 8.5 ft (2.6 m) and higher. Original design by Lievore, Altherr & Molina for Madel.



DCG

Highlights

- Heavy-gauge aluminum construction
- Fully adjustable
- Powder paint coating - White (Custom Finishes Avail.)
- Available in Imperial and Metric dimensions



Imperial

Listed Size	Duct Size	A (in)	C (in)	E (in)	H (in)	K (in)	Z (in)
06	6"	19 59/64	5 3/4	13 5/16	4 15/16	1 47/64	1
08	8"	15 5/32	7 3/4	16 47/64	4 17/32	2 9/32	1
10	10"	18 17/64	9 3/4	19 3/8	4 31/64	2 1/4	1
12	12"	22 13/64	11 3/4	23 17/64	6 19/32	3 5/32	1
14	14"	24 13/16	13 29/32	26 1/16	5 33/64	3 17/64	1
16	16"	24 13/16	15 43/64	26 1/16	5 5/32	2 59/64	1
18	18"	31 7/32	17 19/32	32 3/4	6 13/16	4 11/64	1
20	20"	31 7/32	19 9/16	32 3/4	6 27/64	3 13/16	1

Metric

Listed Size	Duct Size	A (mm)	C (mm)	E (mm)	H (mm)	K (mm)	Z (mm)
160	160 mm	303	157	331	101	44	25
200	200mm	385	197	425	115	58	25
250	250mm	464	247	492	114	57	25
315	315mm	564	313	591	137	80	25
355	355mm	630	353	662	140	83	25
400	400mm	630	398	662	131	74	25
450	450mm	793	447	832	173	106	25
500	500mm	793	497	832	163	97	25

ENGINEERING PERFORMANCE DATA

MODEL DCG ADJUSTABLE ROUND DIFFUSER



Recommended Velocity and CFM

Neck Diameter	Free Area (sqft)	Vmin (fpm)	Vmax (fpm)	Min cfm	Max cfm
6" (160 mm)	0.215	590	1122	126	241
8" (200 mm)	0.338	590	1142	200	388
10" (250 mm)	0.527	590	886	312	468
12" (315 mm)	0.839	590	1122	491	950
14" (355 mm)	1.035	590	1220	609	1279
16" (400 mm)	1.345	590	1181	794	1606
18" (450 mm)	1.711	590	886	917	1561
20" (500 mm)	2.110	590	886	1112	1858

Isothermal Performance Data in Horizontal Flow Position

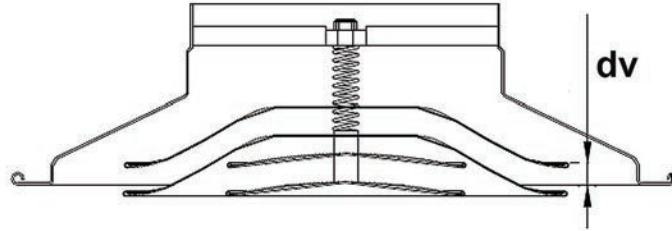
SIZE	Neck Velocity (fpm)	400	500	600	700	800	1000	1200	1400	1600
	Velocity Pressure (in H ₂ O)	.010	.016	.023	.031	.040	.063	.090	.122	.160
6" 160 mm	CFM	79	98	118	137	157	196	236	275	314
	Pressure Loss (in wg.)	.032	.044	.060	.080	.104	.153	.241	.301	.402
	NC	< 15	< 15	< 20	20	< 20	30	< 35	> 35	> 35
	Throw - Radius (ft)	4	5	6	9	11	13	17	20	25
8" 200 mm	CFM	140	175	209	244	279	349	419	489	559
	Pressure Loss (in wg.)	.028	.036	.056	.072	.096	.149	.209	.281	.361
	NC	< 15	< 15	< 20	30	< 35	< 35	35	> 35	> 35
	Throw - Radius (ft)	5	7	9	11	12	14	17	19	22
10" 250 mm	CFM	218	273	327	382	436	545	654	764	873
	Pressure Loss (in wg.)	.040	.060	.092	.120	.161	.249	.402	.602	-
	NC	< 15	< 15	< 20	< 25	< 30	35	> 35	> 35	-
	Throw - Radius (ft)	7	9	11	13	15	20	25	33	-
12" 315 mm	CFM	314	393	471	550	628	785	942	1100	1257
	Pressure Loss (in wg.)	.040	.056	.096	.129	.201	.309	.482	.703	-
	NC	< 15	< 20	< 30	30	< 40	> 40	> 40	> 40	-
	Throw - Radius (ft)	11	12	14	16	17	19	22	-	-
14" 355 mm	CFM	428	535	641	748	855	1069	1283	1497	1710
	Pressure Loss (in wg.)	.032	.052	.072	.108	.149	.221	.361	.482	.602
	NC	< 15	20	25	< 30	< 35	< 40	> 40	> 40	> 40
	Throw - Radius (ft)	10	12	15	17	18	21	26	27	-
16" 400 mm	CFM	559	698	838	977	1117	1396	1676	1955	2234
	Pressure Loss (in wg.)	.044	.072	.108	.129	.145	.241	.321	.462	.562
	NC	< 15	< 25	< 30	< 35	35	> 40	> 40	> 40	> 40
	Throw - Radius (ft)	11	14	15	16	17	19	21	-	-
18" 450 mm	CFM	707	884	1060	1237	1414	1767	2121	2474	-
	Pressure Loss (in wg.)	.052	.064	.116	.157	.221	.361	.542	.803	-
	NC	< 20	< 25	< 30	< 35	< 40	> 40	> 40	> 40	-
	Throw - Radius (ft)	13	15	17	18	19	22	25	-	-
20" 500 mm	CFM	873	1091	1309	1527	1745	2182	2618	-	-
	Pressure Loss (in wg.)	.039	.060	.080	.100	.141	.233	.321	-	-
	NC	25	< 3	< 35	35	< 40	> 40	> 40	-	-
	Throw - Radius (ft)	13	15	17	19	21	25	29	-	-
Downward Projection of Heated Air (in ft)	10 Degrees F Diff.	6 - 6	8 - 8	10 - 12	13 - 15	15 - 19	19 - 25	21 - 32	25 - 38	27 - 40
	20 Degrees F Diff.	4 - 4	6 - 7	7 - 8	9 - 11	10 - 14	13 - 18	15 - 17	17 - 25	19 - 29
	30 Degrees F Diff.	3 - 3	5 - 5	6 - 7	7 - 9	9 - 11	11 - 15	13 - 18	14 - 20	15 - 24
	40 Degrees F Diff.	3 - 2	4 - 4	5 - 6	7 - 8	8 - 10	10 - 13	11 - 16	12 - 18	14 - 20

Performance Notes

- NC value based on 10 db room attenuation
- Throw values are based on isothermal air and terminal velocity of 40 fpm
- For exposed duct application, multiply throw values by 0.7
- Downward Projection of Heated Air values represent the distance to a total air velocity of essentially zero. The two values are for 6" neck and 12" neck. In horizontal position.

ENGINEERING PERFORMANCE DATA

Vertical Flow Adjustment



SIZE	Neck Velocity (fpm)	400	500	600	700	800	1000	1200	1400	1600
6" 160 mm	CFM	79	98	118	137	157	196	236	275	314
	dv = 13/64" (5 mm)	5 - x	7 - x	9 - x	11 - x	12 - 5	16 - 8	20 - 10	23 - 11	28 - 13
	dv = 5/16" (8 mm)	8 - x	10 - x	12 - 5	15 - 7	18 - 9	22 - 11	28 - 13	33 - 16	x - 19
	dv = 19/32" (15 mm)	12 - x	15 - 7	17 - 9	22 - 11	25 - 13	32 - 16	x - 19	x - 23	x - 28
8" 200 mm	CFM	140	175	209	244	279	349	419	489	559
	dv = 5/16" (8 mm)	9 - 3	11 - 5	12 - 7	13 - 8	14 - 9	17 - 10	19 - 11	x - 13	x - 14
	dv = 25/64" (10 mm)	12 - 7	14 - 8	16 - 9	17 - 11	18 - 11	22 - 13	25 - 15	x - 17	x - 18
	dv = 29/32" (23 mm)	16 - 10	19 - 11	21 - 13	24 - 14	25 - 15	31 - 18	33 - 20	x - 23	x - 25
10" 250 mm	CFM	218	273	327	382	436	545	654	764	873
	dv = 13/64" (5 mm)	11 - x	12 - 5	14 - 7	16 - 8	18 - 9	21 - 11	x - 13	x - 15	x - 18
	dv = 25/64" (10 mm)	15 - 7	17 - 9	20 - 11	22 - 12	25 - 13	30 - 15	x - 19	x - 22	x - 25
	dv = 45/64" (18 mm)	19 - 10	22 - 11	25 - 14	28 - 15	32 - 16	x - 20	x - 23	x - 28	x - 31
12" 315 mm	CFM	314	393	471	550	628	785	942	-	-
	dv = 33/64" (13 mm)	11 - 6	14 - 7	18 - 10	21 - 13	28 - 16	x - 19	x - 25	-	-
	dv = 25/32" (20 mm)	16 - 8	19 - 10	25 - 14	30 - 17	38 - 21	x - 27	x - 36	-	-
	dv = 1 1/16" (27 mm)	21 - 12	26 - 15	36 - 19	41 - 23	54 - 28	x - 38	x - 51	-	-
14" 355 mm	CFM	428	535	641	748	855	1069	1283	1497	-
	dv = 25/64" (10 mm)	7 - 3	9 - 6	12 - 8	15 - 9	18 - 11	21 - 15	30 - 19	x - 21	-
	dv = 19/32" (15 mm)	11 - 6	15 - 10	19 - 13	23 - 15	29 - 18	36 - 22	51 - 31	x - 36	-
	dv = 29/32" (23 mm)	18 - 10	22 - 15	30 - 19	36 - 23	44 - 27	59 - 35	x - 49	x - 56	-
16" 400 mm	CFM	559	698	838	977	1117	1396	1676	1955	-
	dv = 13/64" (5 mm)	13 - 9	16 - 11	20 - 13	21 - 15	25 - 16	28 - 19	x - 23	x - 26	-
	dv = 5/16" (8 mm)	18 - 12	22 - 16	27 - 18	30 - 20	x - 22	x - 28	x - 33	-	-
	dv = 35/64" (14 mm)	24 - 16	31 - 21	x - 24	x - 27	x - 30	-	-	-	-
18" 450 mm	CFM	707	884	1060	1237	1414	1767	2121	2474	-
	dv = 45/64" (18 mm)	17 - 10	20 - 11	22 - 13	25 - 15	28 - 17	x - 20	x - 22	x - 25	-
	dv = 63/64" (25 mm)	24 - 14	27 - 16	31 - 18	x - 20	x - 23	x - 27	x - 31	-	-
	dv = 1 3/8" (35 mm)	29 - 17	32 - 19	x - 22	x - 25	x - 27	x - 32	-	-	-
20" 500 mm	CFM	873	1091	1309	1527	17465	2182	2618	-	-
	dv = 45/64" (18 mm)	12 - 8	15 - 10	17 - 11	19 - 12	21 - 14	x - 16	x - 19	-	-
	dv = 63/64" (25 mm)	15 - 10	19 - 12	21 - 13	24 - 15	27 - 17	x - 20	x - 24	-	-
	dv = 1 3/8" (35 mm)	21 - 13	26 - 16	30 - 18	33 - 20	x - 23	x - 28	x - 33	-	-

Performance Notes

- Vertical throw values (in ft) are for isothermal (first value) and for a temperature difference of 9°F (5°C) in heating mode (second value), at terminal velocity of 40 fpm.
- **dv** is the vertical adjustment of the diffuser core and is measured by the core offset towards the inside of the diffuser, compared to its original horizontal position.
- **x** means the value is not available.

How to Specify DCG Series

Supply and mounting of adjustable round diffuser series DCG, constructed from aluminum and powder coated in white M9016. Full vertical adjustability provided by rotating the core clockwise or counterclockwise. By Airvector Specialty Products/MADEL.

ENGINEERING PERFORMANCE DATA



HOW TO ORDER DCG ROUND DIFFUSERS

DCG 08

MODEL SERIES

Fully Adjustable Aluminum **DCG**

ROUND NECK

Imperial		Metric	
6"	06	160 mm	160
8"	08	200 mm	200
10"	10	250 mm	250
12"	12	315 mm	315
14"	14	355 mm	355
16"	16	400 mm	400
18"	18	450 mm	450
20"	20	500 mm	500

DISPLACEMENT DIFFUSER



Rev. 0

DDC SERIES

Ceiling-Mounted Displacement Diffuser

Quiet, Even Air Distribution from Above

The Airvector® **DDC** Series is a ceiling-mounted displacement diffuser designed to deliver low-velocity, laminar airflow directly into the occupied zone from a standard suspended ceiling. By introducing cool, conditioned air uniformly across its perforated face with minimal turbulence, the **DDC** maintains exceptional indoor air quality, thermal comfort, and acoustic performance.

Unlike traditional mixing diffusers, the **DDC** supplies fresh air that gently descends through the room, displacing warm and contaminated air upward toward the return zone. This stratified airflow pattern improves ventilation effectiveness while maintaining quiet, draft-free comfort, making the **DDC** especially well-suited for installations with limited floor or wall availability, circulation zones such as hallways and corridors, and perimeter locations where overhead delivery is preferred.

The **DDC** integrates seamlessly into any T-bar ceiling system, preserving valuable floor and wall space while maintaining a clean architectural finish. Its durable aluminum and steel construction ensures long-term reliability, while optional color finishes allow the diffuser to blend effortlessly into any interior design.

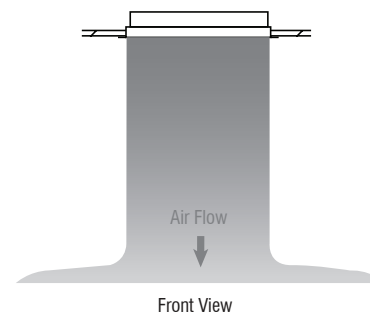
GENERAL FEATURES

- Low-velocity laminar airflow from ceiling into the occupied zone.
- Integrated equalization baffle ensures quiet and uniform air distribution.
- T-bar ceiling mount allows quick installation and space-saving integration.
- Durable aluminum and coated steel construction for long-lasting use.
- Powder-coated white finish (standard); custom colors available.
- Ideal for offices, classrooms, and corridors.

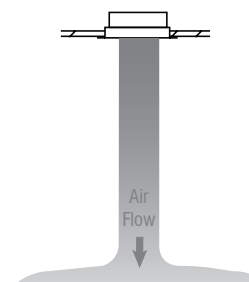


DDC

AIR PATTERNS



Front View



Side View
(when rectangular diffuser)

Ceiling-Mounted Displacement Diffuser DDC

Unit Size W x H	Inlet Size	Face Velocity (fpm)	CFM / ft	Total Pressure	Ps	NC
12 x 24	6	20	26	-	-	-
		30	38	0.01	0.01	-
		40	50	0.02	0.02	-
		50	63	0.04	0.03	-
24 x 24	8	20	60	-	-	-
		30	90	0.02	0.02	-
		40	120	0.03	0.03	-
		50	151	0.05	0.04	15
24 x 48	10	20	130	0.01	0.01	-
		30	193	0.03	0.03	-
		40	258	0.06	0.05	21
		50	322	0.09	0.07	26

SYMBOLS Ps Static Pressure in inches of water
 NC Noise Criteria based on 10 db room absorption
 Total Pressure in water gauge

- ΔT is the difference between the room air temperature 3½ ft above the floor and the temperature of the supply air.
- Data based on test results according to ASHRAE Standard 70-2023 Performance of Air Outlets and Inlets.
- "Proximity to outlet" refers to the minimum distance between a diffuser and an occupant needed to achieve the specified DR value.
- Being closer than this distance results in a higher DR than what's listed.
- Draft Rating estimates the percentage of people likely to feel discomfort from drafts. A DR

- below 20 complies with ASHRAE Standard 55-2004.
- A dash "-" means the DR remains below the threshold at all measured distances from the diffuser.
- DR values are based on an occupant density of 25 people per 1000 ft², the ASHRAE 62.1-2004 default for classrooms (ages 5-8).
- The "Adjacent zone" is the distance from the diffuser face where the air velocity drops to 50 fpm, measured 1 inch above the floor.

DISPLACEMENT DIFFUSER



Rev. 0

DDO SERIES

Full-Circle 360° Displacement Diffuser

Uniform, Low-Velocity Air Distribution in Every Direction

The Airvector® **DDO** Series is a full-circle displacement diffuser designed to deliver low-velocity, 360° air distribution for optimal comfort and air quality. Installed freestanding or duct-hung, the **DDO** supplies conditioned air evenly across its perforated surface, creating a gentle outward flow along the floor. This low-turbulence displacement pattern promotes stratified ventilation, cool, clean air settles in the occupied zone while warm, contaminated air is displaced upward for extraction.

Engineered for high-performance and architectural integration, the **DDO** enhances both comfort and aesthetics in large open spaces such as lobbies, atriums, classrooms, offices, hotels, and convention centers. Its sleek cylindrical form allows installation where wall- or ceiling-mounted diffusers are impractical.

Constructed from powder-coated steel and aluminum with an internal equalization baffle, the **DDO** ensures quiet, even airflow and long-lasting durability. Optional base and duct cover accessories provide a finished look that conceals ductwork and integrates seamlessly into any interior design.

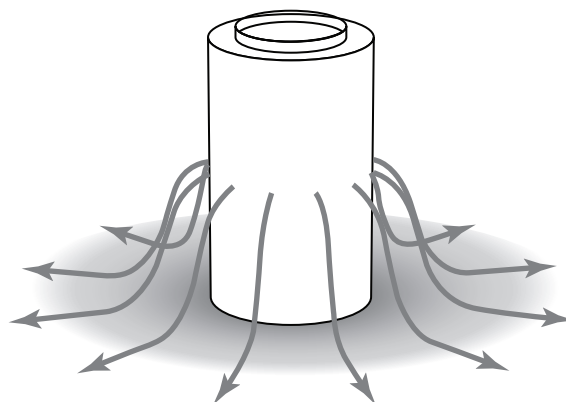
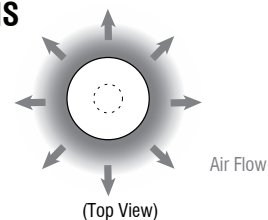
GENERAL FEATURES

- 360° radial air discharge for full, uniform coverage.
- Integrated baffle ensures consistent, low-velocity discharge.
- Low sound operation with minimal turbulence.
- Freestanding or duct-hung mounting configurations.
- Durable aluminum and steel construction with powder-coated finish.
- Optional base and duct cover accessories.



DDO

AIR PATTERNS



Full-Circle 360° Displacement Diffuser - Freestanding Unit DDO

Unit Size Dia. x H	Inlet Size	Face Velocity (fpm)	CFM / ft	Total Pressure	Ps	NC
18 x 36	14	20	270	-	-	-
		30	405	0.02	0.01	-
		40	540	0.04	0.02	-
		50	675	0.06	0.03	-
24 x 36	14	20	360	0.01	-	-
		30	540	0.03	0.01	-
		40	722	0.05	0.02	-
		50	902	0.07	0.04	17
30 x 36	14	20	452	0.03	-	-
		30	678	0.04	0.01	-
		40	904	0.07	0.02	16
		50	1130	0.11	0.03	23
18 x 48	14	20	363	0.01	-	-
		30	545	0.03	0.01	-
		40	726	0.05	0.02	-
		50	908	0.08	0.04	-
24 x 48	14	20	486	0.02	-	-
		30	728	0.04	0.01	-
		40	971	0.07	0.02	17
		50	1214	0.11	0.03	24
30 x 48	16	20	608	0.02	-	-
		30	912	0.04	0.01	-
		40	1216	0.07	0.02	16
		50	1520	0.10	0.03	23
24 x 60	16	20	610	0.02	-	-
		30	915	0.04	0.01	-
		40	1220	0.07	0.02	-
		50	1526	0.10	0.03	22
30 x 60	18	20	765	0.02	-	-
		30	1146	0.03	-	-
		40	1527	0.06	0.01	-
		50	1910	0.10	0.02	23
36 x 36	18	20	543	0.01	-	-
		30	814	0.02	0.01	-
		40	1086	0.04	0.02	-
		50	1355	0.07	0.03	-
36 x 48	20	20	730	0.01	-	-
		30	1095	0.03	0.01	-
		40	1460	0.05	0.02	-
		50	1825	0.07	0.03	16
48 x 42	20	20	850	0.01	-	-
		30	1275	0.03	-	-
		40	1700	0.05	0.02	-
		50	2125	0.08	0.03	21
48 x 48	20	20	975	0.01	-	-
		30	1463	0.03	-	-
		40	1950	0.06	0.01	18
	22	30	1463	0.03	-	-
		40	1950	0.05	0.02	-
		50	2438	0.08	0.02	20

SYMBOLS Ps Static Pressure in inches of water
 NC Noise Criteria based on 10 db room absorption, re 10⁻¹² watts and one diffuser.
 Total Pressure in water gauge

- ΔT is the difference between the room air temperature 3½ ft above the floor and the temperature of the supply air.
- Data based on test results according to ASHRAE Standard 70-2006 Performance of Air Outlets and Inlets.
- "Proximity to outlet" refers to the minimum distance between a diffuser and an occupant needed to achieve the specified DR value.
- Being closer than this distance results in a higher DR than what's listed.
- Draft Rating estimates the percentage of people likely to feel discomfort from drafts. A DR

- below 20 complies with ASHRAE Standard 55-2004.
- A dash "-" means the DR remains below the threshold at all measured distances from the diffuser.
- DR values are based on an occupant density of 25 people per 1000 ft², the ASHRAE 62.1-2004 default for classrooms (ages 5–8).
- The "Adjacent zone" is the distance from the diffuser face where the air velocity drops to 50 fpm, measured 1 inch above the floor.

Full-Circle 360° Displacement Diffuser - Ceiling-Suspended Unit DDO

Unit Size Dia. x H	Inlet Size	Face Velocity (fpm)	CFM / ft	Total Pressure	Ps	NC
18 x 24	18	20	177	-	-	-
		30	265	0.01	-	-
		40	352	0.02	0.02	-
		50	441	0.03	0.03	-
24 x 24	24	20	236	-	-	-
		30	354	-	-	-
		40	473	0.01	0.01	-
		50	591	0.02	0.02	-
30 x 24	30	20	296	-	-	-
		30	444	-	-	-
		40	592	-	-	-
		50	740	0.01	0.01	-
18 x 36	18	20	270	-	-	-
		30	405	0.01	0.01	-
		40	540	0.02	0.02	-
		50	675	0.04	0.03	-
24 x 36	24	20	361	-	-	-
		30	541	0.01	-	-
		40	722	0.02	0.02	-
		50	902	0.03	0.03	-
30 x 36	30	20	452	-	-	-
		30	678	-	-	-
		40	904	0.01	0.01	-
		50	1130	0.02	0.02	-
18 x 48	18	20	363	-	-	-
		30	545	-	-	-
		40	727	-	-	-
		50	909	0.01	-	-
24 x 48	24	20	485	-	-	-
		30	727	0.01	-	-
		40	971	0.02	0.01	-
		50	1213	0.03	0.02	-
30 x 48	30	20	607	-	-	-
		30	912	0.01	-	-
		40	1216	0.02	0.01	-
		50	1520	0.03	0.02	-
24 x 60	24	20	610	-	-	-
		30	915	-	-	-
		40	1220	-	-	-
		50	1525	0.01	-	-
30 x 60	30	20	764	-	-	-
		30	1146	-	-	-
		40	1528	0.02	0.01	-
		50	1910	0.03	0.02	-

SYMBOLS Ps Static Pressure in inches of water
 NC Noise Criteria based on 10 db room absorption, re 10⁻¹² watts and one diffuser.
 Total Pressure in water gauge

- ΔT is the difference between the room air temperature 3½ ft above the floor and the temperature of the supply air.
- Data based on test results according to ASHRAE Standard 70-2006 Performance of Air Outlets and Inlets.
- "Proximity to outlet" refers to the minimum distance between a diffuser and an occupant needed to achieve the specified DR value.
- Being closer than this distance results in a higher DR than what's listed.
- Draft Rating estimates the percentage of people likely to feel discomfort from drafts. A DR

- below 20 complies with ASHRAE Standard 55-2004.
- A dash "-" means the DR remains below the threshold at all measured distances from the diffuser.
- DR values are based on an occupant density of 25 people per 1000 ft², the ASHRAE 62.1-2004 default for classrooms (ages 5-8).
- The "Adjacent zone" is the distance from the diffuser face where the air velocity drops to 50 fpm, measured 1 inch above the floor.

DISPLACEMENT DIFFUSER



Rev. 0

DDQ SERIES

Quarter-Circle 90° Displacement Diffuser

Discreet Corner Diffuser for Low-Velocity Air Distribution

The Airvector® **DDQ** Series is a 90° displacement diffuser designed for corner-mounted applications, delivering low-velocity air in a smooth, horizontal pattern. Its quarter-round perforated face supplies air evenly across the diffuser surface with minimal turbulence, ensuring quiet operation and enhanced comfort.

The **DDQ** is typically installed where space or layout constraints make wall, ceiling, or floor-mounted displacement diffusers impractical. By supplying conditioned air directly into the occupied zone, the **DDQ** promotes a stratified ventilation effect—cool, clean air remains at occupant level while warm and contaminated air naturally rises to the ceiling.

Constructed from coated steel and aluminum with an integrated equalization baffle, the **DDQ** provides uniform airflow and architectural integration. Its curved shape complements modern interior designs while maintaining high ventilation performance and low sound levels.

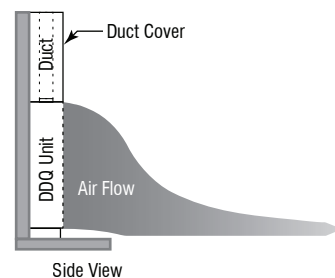
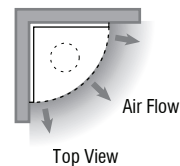
GENERAL FEATURES

- 90° airflow pattern designed for efficient corner ventilation.
- Integrated baffle ensures quiet, even airflow across the perforated face.
- Low-velocity discharge prevents drafts and enhances comfort.
- Compact form factor for floor, wall, or ceiling corner applications.
- Durable steel and aluminum construction with powder-coated finish.
- Optional base and duct covers available.



DDQ

AIR PATTERNS



Quarter-Circle 90° Displacement Diffuser DDQ

Unit Size Dia. x H	Inlet Size	Face Velocity (fpm)	CFM / ft	Total Pressure	Ps	NC
18 x 24	4	20	40	0.03	0.01	-
		30	61	0.06	0.03	-
		40	81	0.10	0.05	19
		50	101	0.16	0.08	26
24 x 24	6	20	55	0.01	-	-
		30	83	0.03	0.02	-
		40	111	0.06	0.04	-
		50	139	0.09	0.06	17
30 x 24	8	20	70	0.01	-	-
		30	106	0.02	0.02	-
		40	141	0.04	0.03	-
		50	176	0.06	0.04	-
18 x 36	4	20	62	0.03	-	-
		30	93	0.06	-	16
		40	124	0.11	-	25
		50	155	0.18	-	33
24 x 36	6	20	85	0.02	0.01	-
		30	127	0.05	0.02	-
		40	170	0.09	0.04	16
		50	212	0.14	0.07	23
30 x 36	8	20	108	0.02	-	-
		30	162	0.04	0.02	-
		40	214	0.06	0.04	-
		50	268	0.10	0.06	17
24 x 48	6	20	113	0.03	-	-
		30	171	0.06	0.01	-
		40	229	0.10	0.02	20
		50	286	0.16	0.03	28
30 x 48	8	20	145	0.02	0.01	-
		30	217	0.05	0.02	-
		40	289	0.08	0.04	-
		50	361	0.13	0.06	21
24 x 60	6	20	143	0.02	-	-
		30	215	0.05	-	-
		40	287	0.09	-	24
		50	359	0.15	-	31
30 x 60	8	20	182	0.02	-	-
		30	273	0.05	0.02	-
		40	364	0.09	0.03	17
		50	455	0.15	0.04	24

SYMBOLS Ps Static Pressure in inches of water
 NC Noise Criteria based on 10 db room absorption, re 10⁻¹² watts and one diffuser.
 Total Pressure in water gauge

- ΔT is the difference between the room air temperature 3½ ft above the floor and the temperature of the supply air.
- Data based on test results according to ASHRAE Standard 70-2006 Performance of Air Outlets and Inlets.
- "Proximity to outlet" refers to the minimum distance between a diffuser and an occupant needed to achieve the specified DR value.
- Being closer than this distance results in a higher DR than what's listed.
- Draft Rating estimates the percentage of people likely to feel discomfort from drafts. A DR

- below 20 complies with ASHRAE Standard 55-2004.
- A dash "-" means the DR remains below the threshold at all measured distances from the diffuser.
- DR values are based on an occupant density of 25 people per 1000 ft², the ASHRAE 62.1-2004 default for classrooms (ages 5-8).
- The "Adjacent zone" is the distance from the diffuser face where the air velocity drops to 50 fpm, measured 1 inch above the floor.

High-Efficiency Ventilation With Enhanced Indoor Air Quality

GENERAL OVERVIEW

A Smarter Approach to Indoor Air Quality and Thermal Comfort

Displacement ventilation is an advanced air distribution strategy designed to optimize indoor air quality, thermal comfort, and energy efficiency. Unlike traditional overhead mixing systems that dilute contaminants throughout the space, displacement systems introduce low-velocity, conditioned air at floor level—directly within the occupied zone. This cooler air spreads across the floor and is naturally drawn upward by heat sources such as occupants, electronic equipment, or lighting, creating gentle thermal plumes. (see Fig. 1).

As the air rises, it carries excess heat, pollutants, and exhaled contaminants out of the breathing zone and toward the ceiling, where it can be exhausted. This stratified airflow pattern results in cleaner, more breathable air at occupant level, while minimizing drafts and operational noise.

Displacement systems like the DDW Series offer superior performance compared to conventional overhead mixing (MV) systems. By supplying warmer air at low velocity and leveraging thermal stratification, they reduce fan energy consumption and extend economizer operation. Recognized by ASHRAE 62.1 with a Zone Air Distribution Effectiveness (EZ) rating of 1.2, the DDW allows engineers to meet ventilation requirements with less outdoor air—improving occupant well-being, supporting LEED® certification, and increasing overall system efficiency.

Wall-mounted displacement diffusers such as the DDW are ideal for environments where floor space is limited and quiet, high-efficiency ventilation is essential—like offices, classrooms, healthcare settings, retail spaces, and auditoriums. Its perforated steel face and integrated baffle system ensure uniform airflow with minimal turbulence and whisper-quiet performance, making it a high-performance, comfort ventilation solution.

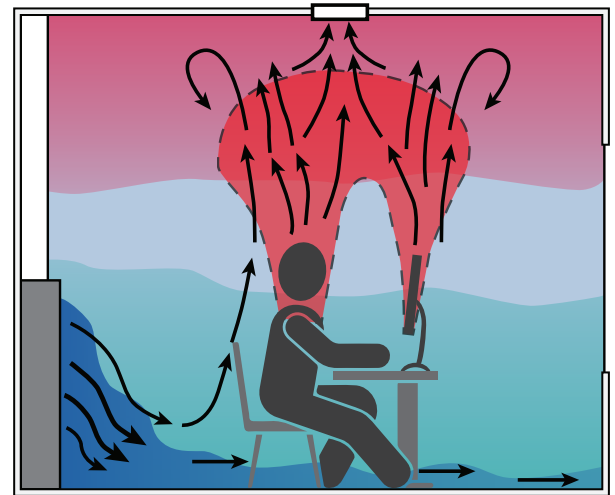


Fig. 1 - Rising air movement created near a heat source.

DISPLACEMENT DIFFUSER



Rev. 0

DDW SERIES Flow Side-Wall Displacement Diffuser

Quiet comfort & optimal air quality right at occupant level

The Airvector® **DDW** Series is a side-wall mounted displacement diffuser engineered to deliver a steady, low-velocity airflow directly into the occupied zone. By introducing conditioned air through a perforated steel face with minimal turbulence, the **DDW** ensures quiet operation, improved indoor air quality, and exceptional thermal comfort. As cooler air gently spreads along the floor and rises naturally with room heat loads, it creates a clean-air “lake” effect, displacing stale air upward and out of the breathing zone.

Thanks to its perforated steel face and internal baffle system, the **DDW** ensures uniform airflow distribution while maintaining whisper-quiet performance. It’s ideal for applications where floor space is limited and air quality is critical, such as classrooms, offices, healthcare environments, theaters, or retail spaces.

Engineered for surface mounting, the **DDW** blends seamlessly into wall designs, offering a modern, unobtrusive appearance.

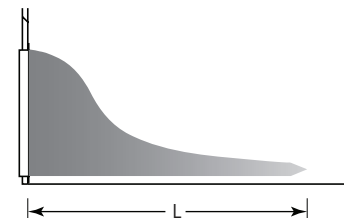
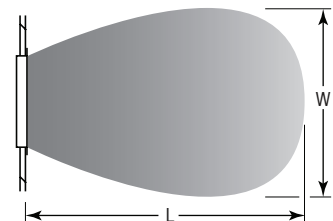
GENERAL FEATURES

- Low-velocity airflow ensures comfortable, draft-free air delivery.
- Integrated baffle promotes uniform, laminar airflow near the floor.
- Quiet operation for classrooms, offices, and theaters.
- Perforated steel front with powder-coated finish for durability.
- Surface-mount design saves floor space.
- Compatible with standard HVAC ducting.
- Custom finishes available for architectural integration.



DDW

AIR PATTERNS



Displacement Flow Side-Wall Diffusers DDW

Size W x H	Inlet Size	Face Velocity (fpm)	CFM / ft	Total Pressure	Ps	NC
14 x 24	2.5 x 12	20	41	-	-	-
		30	64	-	-	-
		40	86	0.01	-	-
		50	115	0.02	0.01	-
14 x 30	2.5 x 12	20	52	-	-	-
		30	80	0.01	-	-
		40	108	0.02	0.01	-
		50	141	0.03	0.02	-
14 x 36	2.5 x 12	20	70	-	-	-
		30	105	0.01	-	-
		40	142	0.02	0.01	-
		50	172	0.04	0.02	-
14 x 48	2.5 x 12	20	87	-	-	-
		30	142	0.02	0.01	-
		40	180	0.04	0.02	-
		50	234	0.06	0.03	16
22 x 24	2.5 x 18	20	64	-	-	-
		30	101	0.01	-	-
		40	128	0.02	0.01	-
		50	168	0.04	0.02	-
22 x 30	2.5 x 18	20	106	-	-	-
		30	133	0.02	-	-
		40	178	0.04	0.02	-
		50	226	0.06	0.03	16
22 x 36	2.5 x 18	20	101	0.01	-	-
		30	162	0.03	0.01	-
		40	206	0.05	0.02	-
		50	265	0.08	0.03	20
22 x 48	2.5 x 18	20	149	0.02	-	-
		30	208	0.04	0.02	-
		40	290	0.08	0.03	21
		50	364	0.13	0.05	28
24 x 30	2.5 x 18	20	89	-	-	-
		30	142	0.02	0.01	-
		40	182	0.04	0.02	-
		50	222	0.06	0.03	17
24 x 36	2.5 x 18	20	110	0.01	-	-
		30	170	0.03	0.01	-
		40	224	0.05	0.02	-
		50	281	0.08	0.04	22
24 x 48	2.5 x 20	20	154	0.02	-	-
		30	226	0.04	0.01	-
		40	298	0.07	0.03	22
		50	367	0.11	0.04	29

SYMBOLS Ps Static Pressure in inches of water
 NC Noise Criteria based on 10 db room absorption
 Total Pressure in water gauge

- ΔT is the difference between the room air temperature 3½ ft above the floor and the temperature of the supply air.
- Data based on test results according to ASHRAE Standard 70-2023

Performance of Air Outlets and Inlets.

- "Proximity to outlet" refers to the minimum distance between a diffuser and an occupant needed to achieve the specified DR value.
- Being closer than this distance results in a higher DR than what's listed.
- Draft Rating estimates the percentage of people likely to feel discomfort from drafts. A DR below 20 complies with ASHRAE Standard 55-2004.
- A dash "-" means the DR remains below the threshold at all measured distances from the diffuser.
- DR values are based on an occupant density of 25 people per 1000 ft², the ASHRAE 62.1-2004 default for classrooms (ages 5-8).
- The "Adjacent zone" is the distance from the diffuser face where the air velocity drops to 50 fpm, measured 1 inch above the floor.

SQUARE DIFFUSERS



Rev. 6

3 CONE DIFFUSERS

Square Ceiling Supply Diffusers

PRODUCT MODELS

Steel Construction

DF3 – Fixed horizontal pattern

DF3D – Fixed horizontal pattern with 2" high neck

DF3I – Insulated (-R6 standard) - Pre-scored for collars

DA3 – Adjustable horizontal air pattern

DA3D – Adjustable horizontal pattern with 2" high neck

Aluminum Construction

ADF3 – Aluminum version of DF3

ADF3D – Aluminum version with 2" high neck

ADF3I – Aluminum insulated - Pre-scored for collars

ADA3 – Aluminum adjustable horizontal pattern

ADA3D – Aluminum adjustable pattern with 2" high neck

The Airvector® 3-cone diffusers series is a complete line of square 3-cone ceiling supply diffusers designed for efficient, quiet, and uniform air distribution in HVAC applications. Available in painted steel or aluminum construction, the 3-cone diffusers series allows designers to select the ideal solution based on performance, weight, or corrosion-resistance requirements.

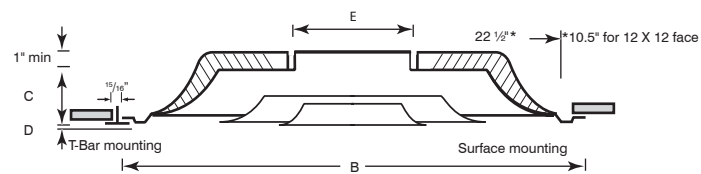
Its round-neck-to-square-face geometry delivers a true 360° horizontal air pattern, similar to a round diffuser, while maintaining a clean architectural ceiling appearance. High induction rates ensure rapid temperature and velocity equalization above the occupied zone, enabling cooling differentials of 30° and greater with low air motion and sound levels typically between NC 25 and 35.

The 3-cone diffusers series performs efficiently from 6 to 30 air changes per hour (based on a 10 ft ceiling height) and is available with fixed or adjustable horizontal patterns, insulated configurations, and multiple neck options to suit a wide range of ceiling and airflow conditions.

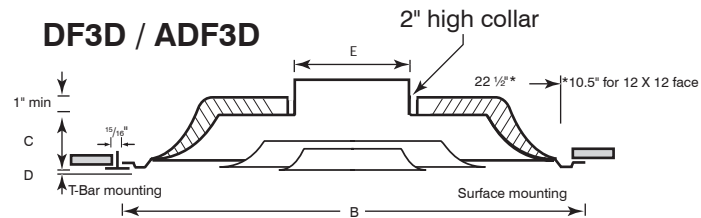


DF3

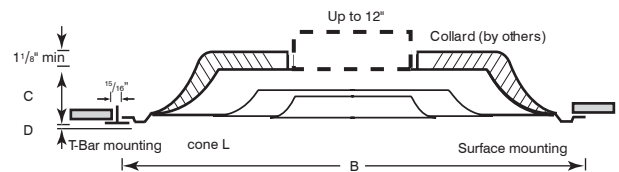
DF3 / ADF3



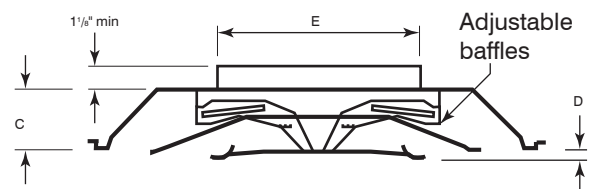
DF3D / ADF3D



DF3I / ADF3I



DA3 / ADA3



DATA SHEET

DF3/ADF3 - DA3/ADA3 SERIES 3 CONE DIFFUSERS

HOW TO ORDER DF3/ADF3 - DA3/ADA3 SERIES

Enhanced Airflow for Large-Volume Applications

KEY FEATURES (ALL MODELS)

- **High Induction Air Distribution**
3-cone design ensures rapid air mixing and uniform temperature distribution.
- **360° Horizontal Air Pattern**
Even air diffusion across the ceiling plane for consistent coverage.
- **Quiet Operation**
Engineered for low sound levels in comfort-driven environments.
- **Steel or Aluminum Heavy-Gauge Construction**
Available in painted steel or aluminum to meet performance or corrosion-resistance requirements.
- **Universal Ceiling Compatibility**
One standard model suits both T-bar and drywall installations using rigid ducts; compatible with Airvector **PF** Easy Install Frame.
- **Service-Friendly Design**
Tool-free removable core allows easy access to duct and damper.

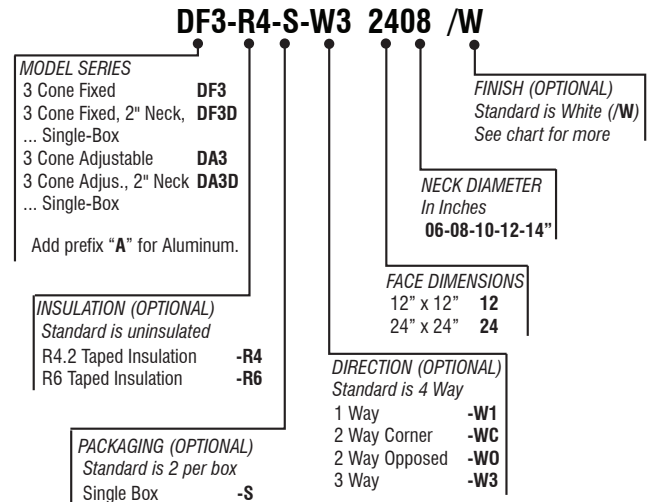
OPTIONS & ACCESSORIES

- Standard white powder-coated finish; custom colors available.
- Optional **-R4** or **-R6** insulation (**-R6** standard on **DF3I** / **ADF3I**)
- Compatible **N4** / **N5** opposed blade dampers, adjustable from the face.
- **PF** Easy Install Frame for drywall ceilings.
- Single-box packaging.

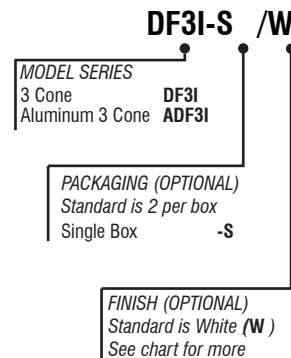
Listed Size	Neck Dia.	Nominal Face Size	Overall Face Size "B"	Drywall Ceiling Opening
1206*	6	12 x 12	11 ³ / ₄ x 11 ³ / ₄	10 ¹ / ₂ x 10 ¹ / ₂
1208*	8	12 x 12	23 ³ / ₄ x 23 ³ / ₄	10 ¹ / ₂ x 10 ¹ / ₂
2406	6	24 x 24	23 ³ / ₄ x 23 ³ / ₄	22 ¹ / ₂ x 22 ¹ / ₂
2408	8	24 x 24	23 ³ / ₄ x 23 ³ / ₄	22 ¹ / ₂ x 22 ¹ / ₂
2410	10	24 x 24	23 ³ / ₄ x 23 ³ / ₄	22 ¹ / ₂ x 22 ¹ / ₂
2412	12	24 x 24	23 ³ / ₄ x 23 ³ / ₄	22 ¹ / ₂ x 22 ¹ / ₂
2414*	14	24 x 24	23 ³ / ₄ x 23 ³ / ₄	22 ¹ / ₂ x 22 ¹ / ₂

* Only available with DF3/ADF3 and DA3/ADA3

All dimensions in inches



HOW TO ORDER DF3I/AISOI



DF3, DF3D, DF3I, DA3, DA3D (steel)
ADF3, ADF3D, ADF3I, ADA3, ADA3D (aluminum)
3-Cone Diffusers

12" x 12" face

SIZE (inches)	Neck Velocity (fpm)	400	500	600	700	800	1000	1200	1400	1600
	Velocity Pressure (in H ₂ O)	.010	.016	.022	.031	.041	.062	.090	.122	.160
6	CFM	78	98	118	137	157	196	235	274	313
	Total Pressure	.02	.03	.04	.06	.07	.10	.16	.22	.29
	NC	< 20	< 20	< 20	< 20	< 20	25	29	34	40
	Throw (ft)	2-3-6	3-4-7	4-5-9	4-5-10	5-6-11	6-8-12	7-9-13	8-10-15	9-11-16
8	CFM	140	175	209	244	279	349	419	489	559
	Total Pressure	.03	.04	.06	.07	.09	.14	.20	.28	.38
	NC	< 20	< 20	< 20	< 20	< 20	29	35	41	45
	Throw (ft)	2-4-7	3-5-9	4-7-10	5-8-11	6-9-12	7-10-14	8-12-17	10-12-18	11-14-20

24" x 24" face

SIZE (inches)	Neck Velocity (fpm)	400	500	600	700	800	1000	1200	1400	1600
	Velocity Pressure (in H ₂ O)	.010	.016	.022	.031	.041	.062	.090	.122	.160
6	CFM	78	98	118	137	157	196	235	274	313
	Total Pressure	.02	.03	.04	.05	.07	.10	.14	.19	.24
	NC	< 20	< 20	< 20	< 20	< 20	22	28	32	36
	Throw (ft)	1-2-4	1-3-4	2-3-5	2-3-6	3-4-7	4-6-8	5-7-10	6-9-11	7-9-12
8	CFM	140	175	209	244	279	349	419	489	559
	Total Pressure	.02	.03	.04	.05	.08	.10	.15	.20	.25
	NC	< 20	< 20	< 20	< 20	< 20	26	31	36	41
	Throw (ft)	2-3-5	2-3-7	3-4-8	3-5-8	4-6-9	5-7-11	6-9-13	7-10-14	8-11-17
10	CFM	218	273	327	382	436	545	654	763	872
	Total Pressure	.02	.03	.04	.05	.08	.12	.17	.24	.30
	NC	< 20	< 20	< 20	< 20	22	29	34	38	43
	Throw (ft)	3-4-6	4-5-8	4-6-10	5-7-12	6-8-14	7-9-15	8-11-16	9-12-17	10-13-19
12	CFM	314	393	471	550	628	785	941	1099	1246
	Total Pressure	.02	.04	.05	.07	.09	.14	.20	.27	.36
	NC	< 20	< 20	< 20	20	23	39	36	41	46
	Throw (ft)	4-5-9	5-6-10	6-7-11	6-8-13	7-9-15	8-11-18	10-13-21	12-16-22	13-18-21
14	CFM	492>	615	738	861	984	1230	1476	1722	1968
	Total Pressure	.03	.04	.06	.08	.10	.18	.23	.30	.40
	NC	< 20	< 20	< 20	21	25	33	38	43	48
	Throw (ft)	4-6-10	5-6-11	6-8-14	7-10-16	8-11-18	10-14-20	12-16-22	14-19-24	15-20-26

NC Value based on 10 db room attenuation.

Throw Values are based on isothermal air and terminal velocities of 150 fpm, 100 fpm & 75 fpm respectively.
Total Pressure the sum of static pressure plus velocity pressure and is given in inches w.g.

SQUARE DIFFUSERS



Rev. 6

4 CONE DIFFUSERS

Efficient, Quiet & Uniform Air Distribution

PRODUCT MODELS

Steel Construction

DF4 – Fixed horizontal pattern

DF4D – Fixed horizontal pattern with 2" high neck

DF4I – Insulated (-R6 standard) - Pre-scored for collars

DA4 – Adjustable horizontal air pattern

DA4D – Adjustable horizontal pattern with 2" high neck

Aluminum Construction

ADF4 – Aluminum version of DF4

ADF4D – Aluminum version with 2" high neck

ADF4I – Aluminum insulated - Pre-scored for collars

ADA4 – Aluminum adjustable horizontal pattern

ADA4D – Aluminum adjustable pattern with 2" high neck

The Airvector® 4-cone is a complete line of square 4-cone ceiling diffusers designed for efficient, quiet, and uniform air distribution in heating, ventilating, and air-conditioning applications. Available in painted steel or aluminum construction, the DF4 Series allows designers and engineers to select the optimal material based on performance, weight, or corrosion-resistance requirements.

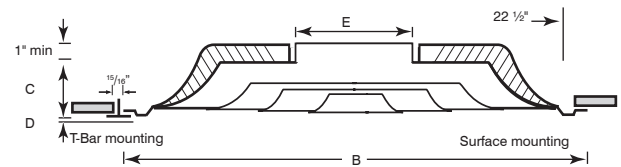
Featuring an integrated round-neck-to-square-face design, 4-cone diffusers deliver a true 360° horizontal air pattern comparable to round diffusers, while maintaining the clean architectural appearance of a 24"x24" square ceiling outlet. High-induction performance ensures rapid temperature and velocity equalization well above the occupied zone, enabling reliable cooling differentials up to 30° at low air motion levels.

The DF4 Series performs efficiently with air loadings of 6 to 30 air changes per hour (based on a 10 ft ceiling height), within a sound level range of NC 25 to 35, making it suitable for comfort-driven commercial and institutional spaces.

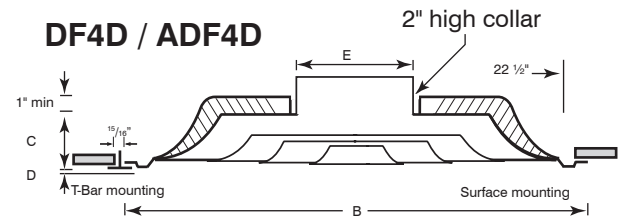


DF4

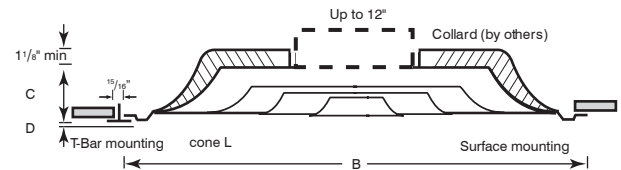
DF4 / ADF4



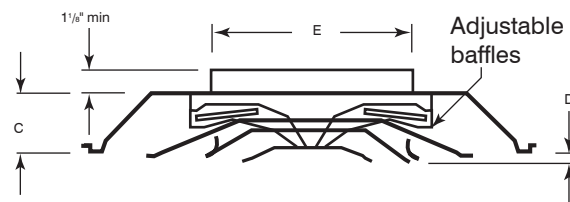
DF4D / ADF4D



DF4I / ADF4I



DA4 / ADA4



DATA SHEET

SQUARE DIFFUSERS

DF4/ADF4 - DA4/ADA4 SERIES 4 CONE DIFFUSERS

HOW TO ORDER DF4/ADF4 - DA4/ADA4 SERIES

Efficient, Quiet & Uniform Air Distribution

KEY FEATURES (ALL MODELS)

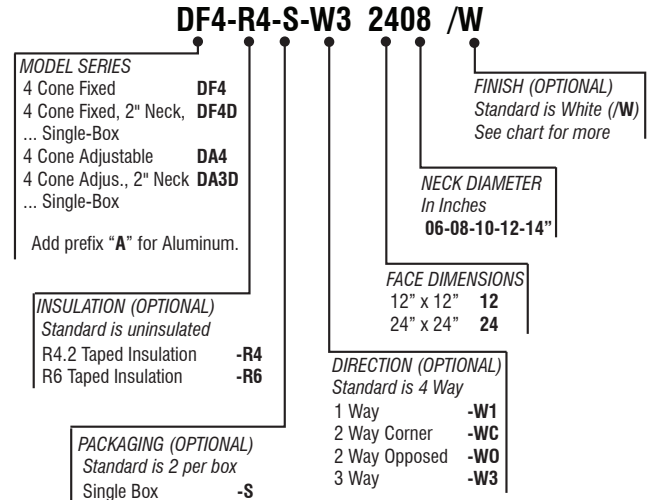
- **High Induction Air Distribution**
4-cone design ensures rapid air mixing and uniform temperature distribution.
- **360° Horizontal Air Pattern**
Even air diffusion across the ceiling plane for consistent coverage.
- **Quiet Operation**
Engineered for low sound levels in comfort-driven environments.
- **Steel or Aluminum Heavy-Gauge Construction**
Available in painted steel or aluminum to meet performance or corrosion-resistance requirements.
- **Universal Ceiling Compatibility**
One standard model suits both T-bar and drywall installations using rigid ducts; compatible with Airvector **PF** Easy Install Frame.
- **Service-Friendly Design**
Tool-free removable core allows easy access to duct and damper.

OPTIONS & ACCESSORIES

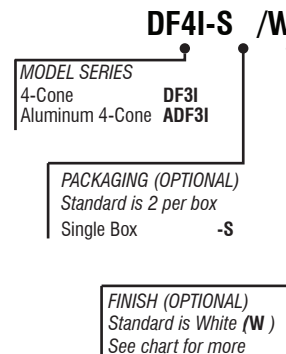
- Standard white powder-coated finish; custom colors available.
- Optional **-R4** or **-R6** insulation (**-R6** standard on **DF4I** / **ADF4I**)
- Compatible **N4** / **N5** opposed blade dampers, adjustable from the face.
- **PF** Easy Install Frame for drywall ceilings.
- Single-box packaging.

Listed Size	Neck Dia.	Nominal Face Size	Overall Face Size "B"
2406	6	24 x 24	23 ³ / ₄ x 23 ³ / ₄
2408	8	24 x 24	23 ³ / ₄ x 23 ³ / ₄
2410	10	24 x 24	23 ³ / ₄ x 23 ³ / ₄
2412	12	24 x 24	23 ³ / ₄ x 23 ³ / ₄
2414*	14	24 x 24	23 ³ / ₄ x 23 ³ / ₄

* Only available with DF4 and DA4



HOW TO ORDER DF4I/ADF4I



DF4, DF4D, DF4I, DA4, DA4D (steel) ADF4, ADF4D, ADF4I, ADA4, ADA4D (aluminum) 4-Cone Diffusers

24" x 24" face

SIZE (inches)	Neck Velocity (fpm)	400	500	600	700	800	1000	1200	1400	1600
	Velocity Pressure (in H ₂ O)	.010	.016	.022	.031	.041	.062	.090	.122	.160
6	CFM	78	98	118	137	157	196	235	274	313
	Total Pressure	.02	.03	.04	.05	.07	.10	.14	.19	.24
	NC	< 20	< 20	< 20	< 20	< 20	< 20	22	28	32
	Throw (ft)	1-2-4	1-3-4	2-3-5	2-3-6	3-4-7	4-6-8	5-7-10	6-9-11	7-9-12
8	CFM	140	175	209	244	279	349	419	489	559
	Total Pressure	.02	.03	.04	.05	.08	.10	.15	.20	.25
	NC	< 20	< 20	< 20	< 20	< 20	26	31	36	41
	Throw (ft)	2-3-5	2-3-7	3-4-8	3-5-8	4-6-9	5-7-11	6-9-13	7-10-14	8-11-17
10	CFM	218	273	327	382	436	545	654	763	872
	Total Pressure	.02	.03	.04	.05	.08	.12	.17	.24	.30
	NC	< 20	< 20	< 20	< 20	< 20	22	29	34	38
	Throw (ft)	3-4-6	4-5-8	4-6-10	5-7-12	6-8-14	7-9-15	8-11-16	9-12-17	10-13-19
12	CFM	314	393	471	550	628	785	941	1099	1246
	Total Pressure	.02	.04	.05	.07	.09	.14	.20	.27	.36
	NC	< 20	< 20	< 20	20	23	39	36	41	46
	Throw (ft)	4-5-9	5-6-10	6-7-11	6-8-13	7-9-15	8-11-18	10-13-21	12-16-22	13-18-21
14	CFM	492>	615	738	861	984	1230	1476	1722	1968
	Total Pressure	.03	.04	.06	.08	.10	.18	.23	.30	.40
	NC	< 20	< 20	< 20	21	25	33	38	43	48
	Throw (ft)	4-6-10	5-6-11	6-8-14	7-10-16	8-11-18	10-14-20	12-16-22	14-19-24	15-20-26

NC Value based on 10 db room attenuation.

Throw Values are based on isothermal air and terminal velocities of 150 fpm, 100 fpm & 75 fpm respectively.

Total Pressure the sum of static pressure plus velocity pressure and is given in inches w.g.

SERIES DLA, DLAM & DLAI



MODEL SERIES DLA, DLAM & DLAI

Aluminum Louvered Face Diffusers Fixed Directional Pattern, High Capacity

DLA aluminum supply diffusers are recommended for heating, ventilating and cooling.

Designed for high capacity, Airvector®'s Model Series DLA can supply large volumes of air at low sound levels and pressure drops. DLA directional diffusers are offered in all standard square dimensions with a variety of cores to provide any required air pattern.

DLA Series feature a square neck, **DLAM** Series feature a round neck and **DLAI** Series feature an R6 insulated back, pre-scored for 6"-14" round collars.

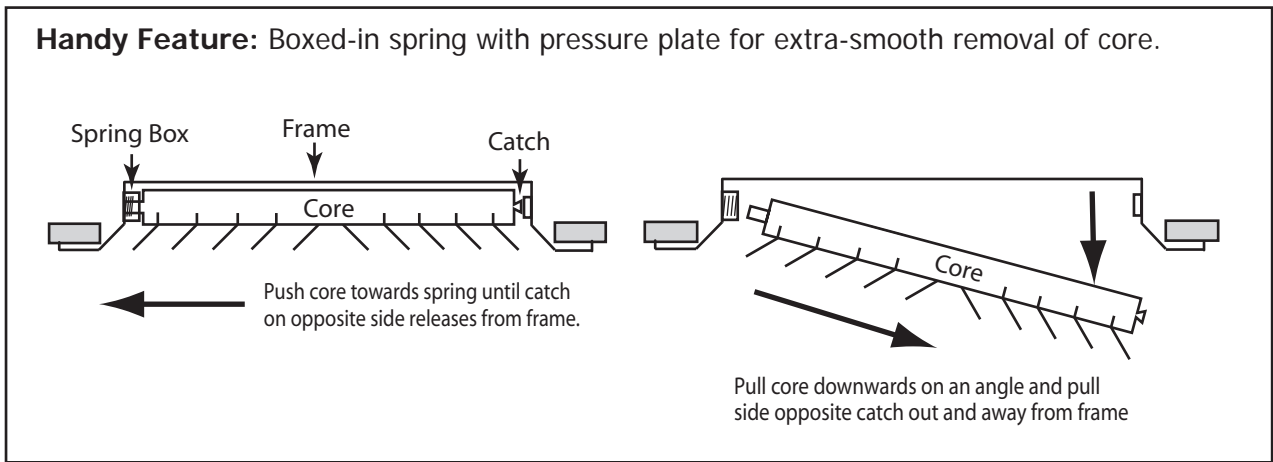
Core is removable to facilitate access to duct.



DLA

FEATURES

- Full Face 12"x12", 15"x15", 18"x18", 21"x21" and 24"x24"
- 1 Way, 2 Way Opposed, 2 Way Corner, 3 Way or 4 Way
- Commercial-grade aluminum construction
- Core can be easily removed without tools
- Ideal for VAV systems
- Powder paint coating - White



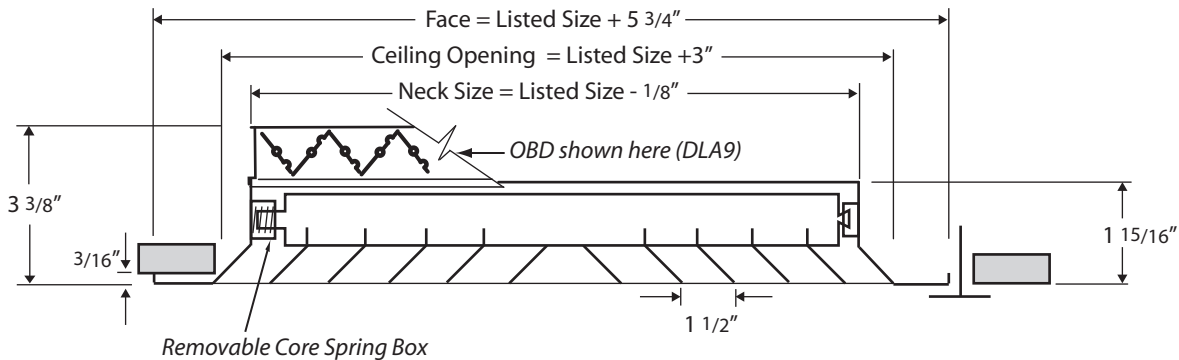
Directional Patterns					
W1	1 Way	WC	2 Way Corner	WO	2 Way Opposed
				W3	3 Way
				W4	4 Way

Border Types		Mounting		
F Flat Frame	B Beveled Frame	0 Lay-In	1 Screw Holes	4 Concealed
	 N/A for DLAI		 N/A for DLAI or Beveled Frame	 N/A for DLAI

MODEL SERIES DLA

MODEL DLA Square Neck

MODEL DLA9 Square Neck With Aluminum Opposed Blade Damper (N9)



HANDY FEATURE: One standard model suits both T-Bar and Drywall installations using rigid ducting.

HOW TO ORDER

DLA-F-0-W4 1818 /W

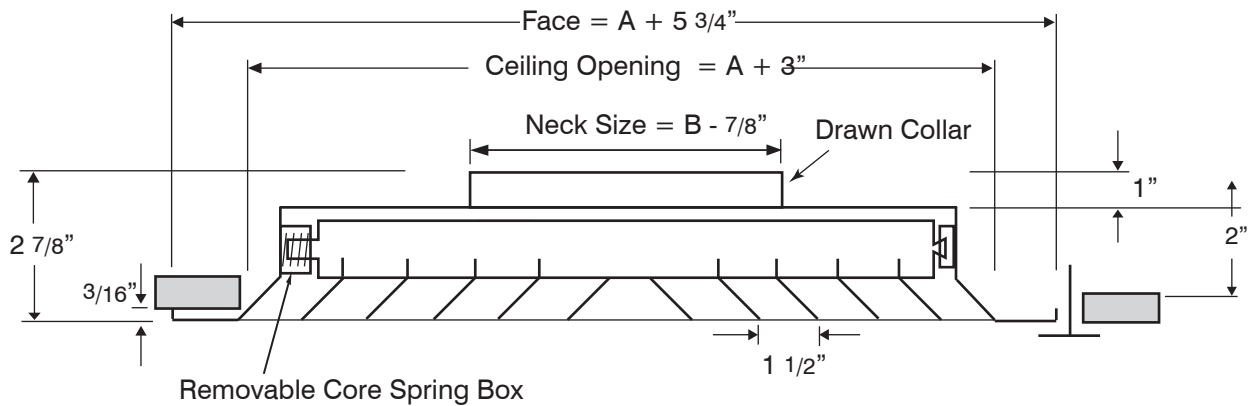
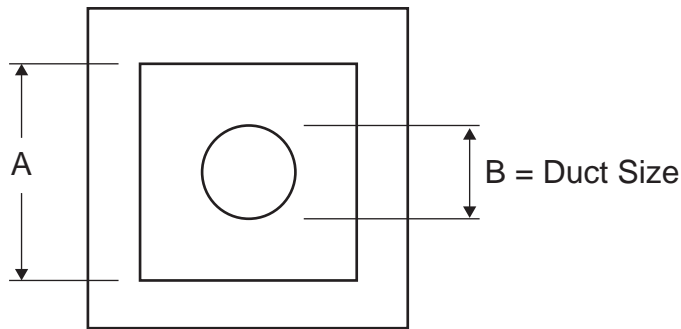
MODEL SERIES Square Neck DLA Square Neck w/ OBD DLA9	FINISH (OPTIONAL) Standard is White (/W) See chart for more
BORDER TYPE (OPTIONAL) Standard is flat frame Flat Frame -F Beveled Frame -B	DUCT DIMENSIONS 6" x 6" 0606 9" x 9" 0909 12" x 12" 1212 15" x 15" 1515 18" x 18" 1818
MOUNTING (OPTIONAL) Standard is Lay-In Lay-In -0 Screw Holes -1 Concealed -4	DIRECTION (OPTIONAL) Standard is 4 Way 1 Way -W1 2 Way Corner -WC 2 Way Opposed -W0 3 Way -W3 4 Way -W4

MODEL SERIES DLAM

MODEL **DLAM** Round Neck

MODEL **DLAM4** Round Neck With Radial Opposed Blade Damper (N4)

MODEL **DLAM5** Round Neck With Radial Sliding Blade Damper (N5)



HANDY FEATURE: One standard model suits both T-Bar and Drywall installations using rigid ducting.

HOW TO ORDER

DLAM-F-0-W4 1818 08 /W

MODEL SERIES	DLAM	Round Neck, No Damper
	DLAM4	With N4 OBD
	DLAM5	With N5 Radial Damper

BORDER TYPE (OPTIONAL)
Standard is flat frame

Flat Frame	-F
Beveled Frame	-B

MOUNTING (OPTIONAL)
Standard is Lay-In

Lay-In	-0
Screw Holes	-1
Concealed	-4

DIRECTION (OPTIONAL)
Standard is 4 Way

1 Way	-W1
2 Way Corner	-WC
2 Way Opposed	-W0
3 Way	-W3
4 Way	-W4

SQUARE TO ROUND NECK DIAMETER

6"	06
8"	08
10"	10
12"	12
14"	14
16"	16

SQUARE NECK DIMENSIONS

6" x 6"	0606
9" x 9"	0909
12" x 12"	1212
15" x 15"	1515
18" x 18"	1818

FINISH (OPTIONAL)
Standard is White (/W)
See chart for more

Dampers Available

DLAM4 With Radial Opposed Blade Damper

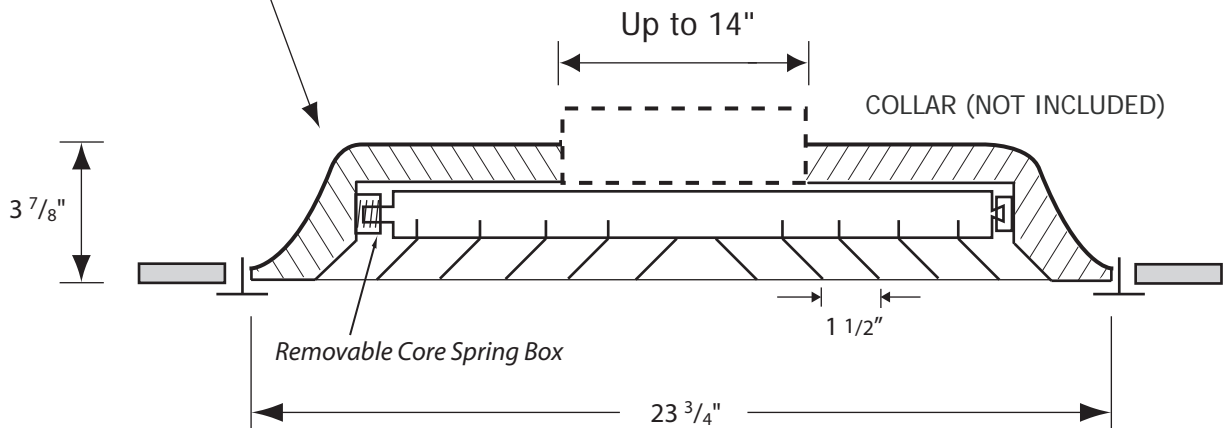
DLAM5 With Radial Sliding Blade Damper

MODEL SERIES DLAI

MODEL DLAI R6 Molded Fiberglass Insulated Back, Pre-Scored for Collars 6"-14"

R6 fiberglass back complies with A.S.T.M. E84 flame and smoke test.

Scored for collar sizes up to 14" D. Contractor to install job-specific collar in field.



HOW TO ORDER

DLAI-W4 /W





















MODEL SERIES
24"x24", R6 Insulated **DLAI**

FINISH (OPTIONAL)
Standard is White (**/W**)
See chart for more

DIRECTION (OPTIONAL)
Standard is 4 Way

- 1 Way **-W1**
- 2 Way Corner **-WC**
- 2 Way Opposed **-WO**
- 3 Way **-W3**
- 4 Way **-W4**

TABLE 1 - PERFORMANCE DATA - SQUARE NECK

Duct Size Blow Pattern	Neck Velocity Velocity Press. Total Press.	300 .006 .030	400 .010 .051	500 .016 .080	600 .022 .118	700 .031 .160	800 .040 .210	900 .050 .260	
6" .25 SQ. FT.	Total CFM NC	75 -	100 -	125 17	150 22	175 26	200 31	225 34	
		A B	A B	A B	A B	A B	A B	A B	
	 A	CFM/Side Throw (ft)	19 4-5-8	25 5-6-9	31 6-8-10	37 6-8-11	44 8-9-12	50 8-9-12	56 9-10-13
	 B	CFM/Side Throw (ft)	19 28 4-5-8 5-8-11	25 38 5-6-9 5-6-9	31 47 6-8-10 8-10-14	38 56 6-8-11 8-11-15	44 66 8-9-12 9-12-16	50 75 8-9-12 9-12-17	56 84 9-10-13 10-13-18
	 A	CFM/Side Throw (ft)	38 8-9-12	50 9-10-14	62 10-11-16	75 11-12-17	88 12-13-18	100 12-14-19	113 13-15-22
 A	CFM/Side Throw (ft)	75 9-11-15	100 10-12-17	125 11-14-19	150 12-15-22	175 13-16-22	200 14-17-24	225 15-18-25	
9" .56 SQ. FT.	Total CFM NC	170 -	225 -	280 20	340 26	395 31	450 35	505 38	
		A B	A B	A B	A B	A B	A B	A B	
	 A	CFM/Side Throw (ft)	42 5-6-10	56 6-8-11	70 8-9-12	84 8-10-13	98 9-10-14	113 9-11-15	126 10-12-16
	 B	CFM/Side Throw (ft)	42 63 5-6-10 8-10-13	56 85 6-8-11 9-11-15	70 106 8-9-12 10-12-17	84 127 8-10-13 11-13-18	98 148 9-10-14 12-14-19	112 169 9-11-15 12-15-22	126 190 10-12-16 13-16-22
	 A	CFM/Side Throw (ft)	84 9-10-15	112 11-13-18	141 12-15-20	169 13-16-22	197 14-17-23	225 15-18-25	253 16-19-28
 A	CFM/Side Throw (ft)	169 12-15-20	225 14-17-23	282 16-19-26	338 17-22-29	394 18-22-31	450 19-24-33	507 22-25-35	
12" 1.0 SQ. FT.	Total CFM NC	300 -	400 17	500 23	600 28	700 32	800 35	900 38	
		A B	A B	A B	A B	A B	A B	A B	
	 A	CFM/Side Throw (ft)	75 6-9-11	100 8-10-13	125 9-11-15	150 10-12-16	175 10-13-17	200 11-14-18	225 12-15-19
	 B	CFM/Side Throw (ft)	75 113 6-9-11 9-11-15	100 150 8-10-13 10-12-17	125 187 9-11-15 11-14-19	150 225 10-12-16 12-15-22	175 263 10-13-17 13-16-22	200 300 11-14-18 14-17-24	225 338 12-15-19 15-18-25
	 A	CFM/Side Throw (ft)	150 11-13-18	200 13-15-22	250 15-17-24	300 16-18-26	350 17-19-28	400 18-22-30	450 19-22-32
 A	CFM/Side Throw (ft)	300 14-17-24	400 16-19-28	500 18-22-32	600 19-23-34	700 22-25-36	800 23-27-38	900 24-29-41	
15" 1.56 SQ. FT.	Total CFM NC	465 -	625 19	780 25	935 29	1090 33	1250 37	1400 41	
		A B	A B	A B	A B	A B	A B	A B	
	 A	CFM/Side Throw (ft)	117 8-10-13	156 9-11-15	195 10-12-17	234 11-13-18	273 12-14-19	313 12-15-22	351 13-16-24
	 B	CFM/Side Throw (ft)	117 176 8-10-13 11-13-18	156 234 9-11-15 13-15-22	195 292 10-12-17 15-17-24	234 352 11-13-18 16-18-26	273 410 12-14-19 17-19-28	313 469 12-15-22 18-22-30	351 527 13-16-24 19-22-32
	 A	CFM/Side Throw (ft)	234 13-16-22	313 15-18-25	390 17-20-29	468 18-22-32	546 19-23-34	625 22-25-36	701 22-28-38
 A	CFM/Side Throw (ft)	468 16-19-28	625 18-22-32	780 20-25-36	936 22-28-39	1092 23-30-42	1250 25-32-44	1405 28-34-47	
18" 2.25 SQ. FT.	Total CFM NC	675 12	900 20	1125 27	1350 31	1575 35	1800 39	2025 42	
		A B	A B	A B	A B	A B	A B	A B	
	 A	CFM/Side Throw (ft)	168 9-11-15	225 10-12-17	281 11-14-19	337 12-15-21	394 13-16-22	450 14-17-24	506 15-18-25
	 B	CFM/Side Throw (ft)	168 253 9-11-15 12-15-20	225 338 10-12-17 9-11-15	281 422 11-14-19 16-19-26	337 506 12-15-21 17-22-29	394 591 13-16-22 18-22-31	450 675 14-17-24 19-24-33	506 758 15-18-25 22-25-35
	 A	CFM/Side Throw (ft)	337 14-17-24	450 16-19-28	562 18-22-32	675 19-23-34	787 22-25-36	900 22-26-39	1013 24-29-41
 A	CFM/Side Throw (ft)	675 17-22-30	900 20-24-34	1125 23-28-39	1350 24-30-41	1575 26-32-44	1800 29-35-47	2025 31-37-50	

Throw values for terminal velocities of
150 fpm, 100 fpm and 50 fpm

Neck Velocity (fpm)
Velocity Pressure (inches of water)
Total Pressure (inches of water)
NC Values based on 10 db room attenuation

TABLE 2 - PERFORMANCE CORRECTIONS SQUARE-TO-ROUND NECK











Square Inlet	Round Inlet	NC (add)	TP (multiply)	Throw (Multiply)		
				150	100	50
9" x 9"	6"	17	3.50	1.15	1.15	1.20
9" x 9"	8"	4	1.40	1.10	1.10	1.10
12" x 12"	8"	17	3.50	1.15	1.15	1.20
12" x 12"	10"	7	1.65	1.10	1.10	1.15
15" x 15"	10"	17	3.50	1.15	1.15	1.20
15" x 15"	12"	9	1.90	1.10	1.10	1.15
15" x 15"	14"	3	1.25	1.05	1.05	1.10
18" x 18"	12"	17	3.50	1.15	1.15	1.20
18" x 18"	14"	10	2.00	1.10	1.10	1.15
18" x 18"	16"	5	1.45	1.10	1.10	1.10

PERFORMANCE CORRECTIONS FOR RETURN AIR APPLICATIONS

Negative Static Pressure Add 10% to Total Pressure listed for supply.

Noise Criteria Add 1 to NC.

TABLE 1 - PERFORMANCE DATA - SQUARE NECK - INDUCTION VANES

Duct Size Blow Pattern	Neck Velocity Velocity Press. Total Press.	100 0.001 0.003	200 0.002 0.0012	300 0.006 0.030	400 0.010 0.051	500 0.016 0.080	600 0.022 0.118	700 0.031 0.160	800 0.040 0.210	900 0.050 0.260	
6" .25 SQ. FT.	Total CFM	25	50	75	100	125	150	175	200	225	
	NC	-	-	-	-	16	21	26	35	39	
		A	B	A	B	A	B	A	B	A	B
	 A	CFM/Side Throw (ft)	6.3 1-2-2	12.6 2-2-4	19 3-4-6	25 3-5-8	31 4-6-8	37 4-6-9	44 5-7-10	50 6-7-11	56 7-8-11
	 B	CFM/Side Throw (ft)	6 1-1-2	9 2-2-3	13 2-2-4	19 2-3-5	28 3-4-6	31 3-4-7	47 4-5-10	56 5-6-12	84 6-8-15
9" .56 SQ. FT.	Total CFM	56	112	170	225	280	340	395	450	505	
	NC	-	-	-	13	18	24	29	39	42	
		A	B	A	B	A	B	A	B	A	B
	 A	CFM/Side Throw (ft)	14 2-2-3	28 2-3-5	43 3-5-8	56 4-5-9	70 4-6-11	84 5-8-13	98 6-9-15	112 7-10-14	126 8-11-14
	 B	CFM/Side Throw (ft)	14 2-2-3	21 2-2-4	28 2-3-5	42 3-4-7	63 3-4-7	85 4-5-9	106 5-7-12	148 6-8-15	190 7-9-18
12" 1.0 SQ. FT.	Total CFM	100	200	300	400	500	600	700	800	900	
	NC	-	-	-	14	21	27	33	40	43	
		A	B	A	B	A	B	A	B	A	B
	 A	CFM/Side Throw (ft)	25 2-2-4	50 3-4-7	75 4-5-10	100 5-7-12	125 6-8-15	150 7-10-19	175 8-11-20	200 10-12-20	225 12-14-21
	 B	CFM/Side Throw (ft)	25 2-2-4	38 2-3-5	50 3-4-7	75 3-5-8	112 4-5-10	150 5-6-12	200 6-8-16	250 7-10-19	338 8-12-23
15" 1.56 SQ. FT.	Total CFM	156	315	465	625	780	935	1090	1250	1400	
	NC	14	23	14	23	29	34	37	43	45	
		A	B	A	B	A	B	A	B	A	B
	 A	CFM/Side Throw (ft)	39 2-3-5	78 3-5-8	117 4-6-12	156 6-8-16	195 7-10-19	234 8-13-22	273 9-14-25	312 11-16-26	350 13-18-32
	 B	CFM/Side Throw (ft)	39 2-3-5	59 3-3-6	78 3-5-8	117 4-6-10	175 4-6-10	234 6-8-15	292 7-10-20	351 8-12-23	409 9-13-24
18" 2.25 SQ. FT.	Total CFM	225	450	675	900	1125	1350	1575	1800	2025	
	NC	16	25	16	25	31	35	40	43	46	
		A	B	A	B	A	B	A	B	A	B
	 A	CFM/Side Throw (ft)	56 3-3-6	112 4-6-10	168 6-8-14	225 8-10-19	281 9-12-23	337 10-15-27	394 12-17-33	450 13-19-34	506 15-20-35
	 B	CFM/Side Throw (ft)	56 3-3-6	84 3-4-6	112 4-6-10	168 5-6-12	253 6-8-15	338 6-9-17	422 7-10-19	590 8-12-22	760 9-12-24

DATA SHEET

Throw values for terminal velocities of
150 fpm, 100 fpm and 50 fpm


Neck Velocity (fpm)
Velocity Pressure (inches of water)
Total Pressure (inches of water)
NC Values based on 10 db room attenuation

PERFORMANCE DATA

Nominal Size (inches)	Core Velocity (FPM) Vel. Press. (in w.g.) Total Press. (TP)	100	200	300	400	500	600	700
			.001	.002	.006	.010	.016	.022
		.003	.0012	.026	.046	.072	.103	.140
6 x 6	CFM	25	50	75	100	125	150	175
	Throw	1-2-2	2-2-4	2-3-5	3-5-7	3-6-7	4-6-10	4-7-12
	NC	-	-	-	-	16	21	26
9 x 9	CFM	56	113	169	225	281	338	394
	Throw	1-2-3	2-3-5	3-5-7	4-5-9	4-6-11	5-8-13	6-9-16
	NC	-	-	-	-	18	23	29
12 x 12	CFM	100	200	300	400	500	600	700
	Throw	2-2-4	3-3-7	4-5-10	5-7-13	6-8-16	7-10-19	8-11-22
	NC	-	-	-	13	20	27	32
15 x 15	CFM	156	313	469	625	781	938	1094
	Throw	2-3-5	3-5-8	4-6-13	6-9-15	7-10-19	8-12-23	12-17-33
	NC	-	-	-	16	22	29	34
18 x 18	CFM	225	450	675	900	1125	1350	1575
	Throw	3-3-6	4-6-10	6-8-15	7-10-19	9-12-24	10-15-28	12-10-19
	NC	-	-	-	16	23	30	35

Performance Notes:

1. NC Value based on 10 dB room attenuation.
2. Throw values are based on isothermal air and terminal velocities of 150 fpm, 100 fpm and 50 fpm.
3. Above table applies for diffuser without OBD. For diffusers c/w OBD multiply by 1.20 the TP figure and add 4 to NC figure above.

 NC > 30 Pressure values are in inches w.g.

ROUND DIFFUSERS



MODEL DRV MINI VALVE DIFFUSER

MODELDRV - Pressed Steel, Adjustable Core

DRV series valves are designed for the air supply or air exhaust in air conditioning, ventilation or heating installations.

Especially suitable for air exhaustion in washrooms and for ventilation installation in houses, apartments, offices, schools and hospitals.

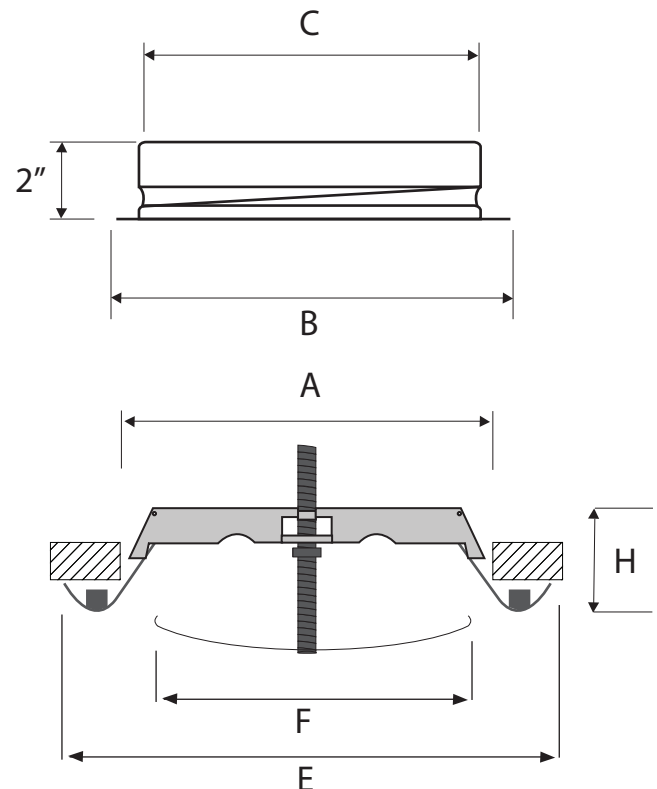
It is mounted in walls or on duct. DRV series valves allow for high airflow pass obtaining good results in sound pressure performance. Flow is easily adjusted by turning the central Highlights

- Ideal for residential applications
- Rotate core clockwise or counter-clockwise to adjust airflow
- Better quality than plastic
- Comes with gasket to avoid air leaks

Neck Diameter	Supply		Return	
	Min cfm	Max cfm	Min cfm	Max cfm
4" (100 mm)	27	40	4	86
5" (125 mm)	40	62	10	127
6" (150 mm)	104	136	10	149
8" (200 mm)	168	252	19	302



DRV



ROUND NECK

Model	Duct Size	A	F	H	C	B	E
DRV 04	4"	4.09"	2.95"	1.57"	3.9"	4.92"	5.39"
DRV 05	5"	5.08"	3.9"	1.81"	4.88"	5.91"	6.46"
DRV 06	6"	6.65"	5.08"	2.13"	5.9"	6.91"	7.75"
DRV 08	8"	8.23"	6.18"	2.48"	7.83"	8.85"	9.76"

HOW TO ORDER DRV SERIES

DRV 04

Model series	Neck dimensions
Mini Valve Diffuser	04 4"
DRV	05 5"
	06 6"
	08 8"

DATA SHEET

SQUARE DIFFUSERS



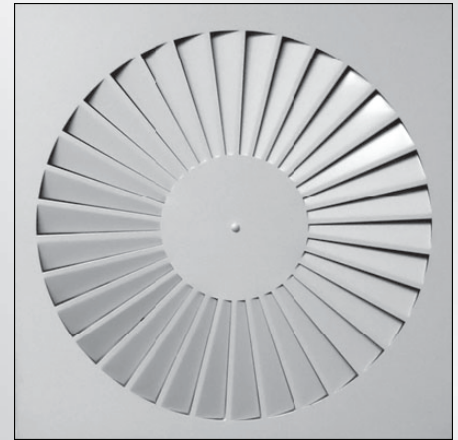
MODELS DSW, DSWI

MODEL **DSW** - Swirl Pattern, Round neck

MODEL **DSWI** - R6 Insulated, Pre-scored for collars

The **DSW Series** supply diffusers are high induction diffusers recommended for both heating and cooling in variable air volume systems.

The **DSW series** provide a 360° radial air diffusion pattern ideal for applications that require high induction rates for rapid temperature and velocity equalization of the mixed air mass above the zone of occupancy.



DSW

Features:

- Full face 24" x 24" for all neck sizes
- Optional 2" neck available for **DSW**
- Lay-in T-Bar ceiling mounting
- Heavy-gauge all-steel construction
- Ideal for VAV systems
- Powder paint coating - White (default) Custom colours avail.

Insulation:

DSW - Optional R4 or R6 insulation. R6 fiberglass insulation complies with A.S.T.M. E84 flame and smoke test. Only available on models with 24" x 24" face.

DSWI- R6 fiberglass insulation.

DSW Model #	Nominal Face Size	Actual Face Size B x B	Duct Size	Actual Neck Size
2406	24 x 24	23 ⁷ / ₈ x 23 ⁷ / ₈	6	5 ⁷ / ₈
2408	24 x 24	23 ⁷ / ₈ x 23 ⁷ / ₈	8	7 ⁷ / ₈
2410	24 x 24	23 ⁷ / ₈ x 23 ⁷ / ₈	10	9 ⁷ / ₈
2412	24 x 24	23 ⁷ / ₈ x 23 ⁷ / ₈	12	11 ⁷ / ₈
2414	24 x 24	23 ⁷ / ₈ x 23 ⁷ / ₈	14	13 ⁷ / ₈

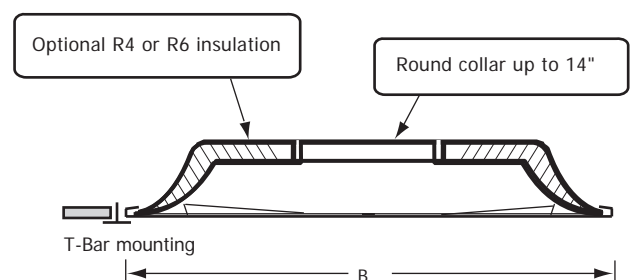
DSWI Model #	Nominal Face Size	Actual Face Size B x B
DSWI	24 x 24	23 ⁷ / ₈ x 23 ⁷ / ₈

All dimensions in inches

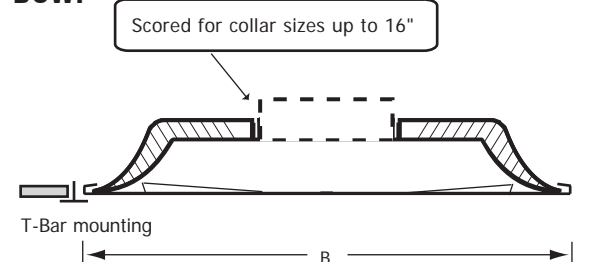


DSWI fiberglass back.

DSW



DSWI



ENGINEERING PERFORMANCE DATA

Square Panel DSW Series 24" x 24" face



SIZE (inches)	Neck Velocity (fpm)	300	400	500	600	700	800	900	1000
	Velocity Pressure (in H ₂ O)	.006	.010	.016	.022	.031	.040	.050	.062
6	CFM	59	79	98	118	137	157	177	196
	Total Pressure	.010	.018	.028	.040	.054	.071	.090	.111
	NC	-	-	-	-	-	18	21	24
	Throw (ft)	1-1-2	1-1-2	1-1-3	1-2-4	1-2-4	2-2-5	2-3-5	2-3-6
8	CFM	105	140	174	209	244	279	314	349
	Total Pressure	.017	.030	.047	.068	.092	.120	.152	.188
	NC	-	-	-	-	19	23	26	29
	Throw (ft)	1-2-3	1-2-4	2-3-5	2-3-6	2-4-7	3-4-7	3-5-8	3-5-8
10	CFM	164	218	273	327	382	436	491	545
	Total Pressure	.029	.051	.079	.114	.156	.203	.257	.318
	NC	-	15	22	27	31	35	38	41
	Throw (ft)	2-2-5	2-3-6	3-4-7	3-5-8	4-6-8	4-6-9	5-7-9	5-7-10
12	CFM	236	314	393	471	550	628	707	785
	Total Pressure	.048	.086	.134	.194	.264	.344	.436	.538
	NC	17	24	31	36	40	44	47	50
	Throw (ft)	2-4-7	3-5-8	4-6-8	6-7-9	5-7-10	6-8-11	7-8-11	7-8-12
14	CFM	321	428	535	641	748	855		
	Total Pressure	.082	.146	.228	.328	.446	.583		
	NC	24	32	38	43	47	51		
	Throw (ft)	3-5-8	4-6-9	5-7-10	6-8-11	7-8-12	7-9-12		
16	CFM	419	558	698	837				
	Total Pressure	.139	.247	.385	.555				
	NC	30	38	44	49				
	Throw (ft)	4-6-9	6-7-13	6-8-11	7-9-12				

NC Noise Criteria Value based on 10 db room attenuation.

Throw Values are based on isothermal air and terminal velocities of 150 fpm 100 fpm, & 50 fpm respectively.

Total Pressure the sum of static pressure plus velocity pressure and is given in inches w.g.

HOW TO ORDER DSW

DSW-R4-W3 2408 /W

MODEL SERIES
Standard Plaque **DSW**
Insulated Plaque **DSWI**

INSULATION (OPTIONAL)
Standard is uninsulated
R4.2 Taped Insulation **-R4**
R6 Taped Insulation **-R6**

FINISH (OPTIONAL)
Standard is White /W
See custom chart for more /C

NECK DIAMETER
06-08-10-12-14"

FACE DIMENSIONS
24" x 24" **24**

DIRECTION (OPTIONAL)
Standard is 4 Way -
1 Way **-W1**
2 Way Corner **-WC**
2 Way Opposed **-WO**
3 Way **-W3**

HOW TO ORDER DSWI

DSWI /W

MODEL SERIES
Swirl Diffuser **DSWI**

FINISH (OPTIONAL)
Standard is White /W
See chart for more

SQUARE DIFFUSERS



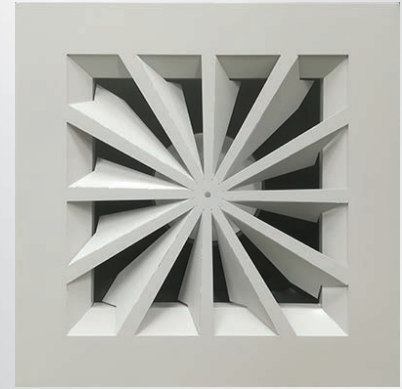
MODELS DTW, DTWI

MODEL **DTW** - Twist Face Supply Diffuser Fixed face

MODEL **DTWI** - R6 Insulated, Pre-scored for collars

The **DTW Series** supply diffusers are high induction diffusers recommended for both heating and cooling in variable air volume systems.

The **DTW series** provide a 360° radial air diffusion pattern ideal for applications that require high induction rates for rapid temperature and velocity equalization of the mixed air mass above the zone of occupancy.



DTW

Features:

- Full face 24" x 24" for all neck sizes
- Optional 2" neck available for **DTW**
- Lay-in T-Bar ceiling mounting
- Heavy-gauge all-steel construction
- Ideal for VAV systems
- Powder paint coating - White (default) Custom colours avail.

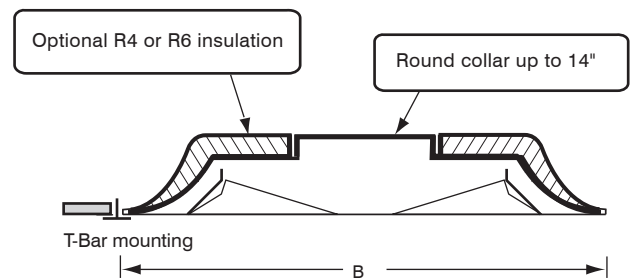
Insulation:

DTW - Optional R4 or R6 insulation. R6 fiberglass insulation complies with A.S.T.M. E84 flame and smoke test. Only available on models with 24" x 24" face.

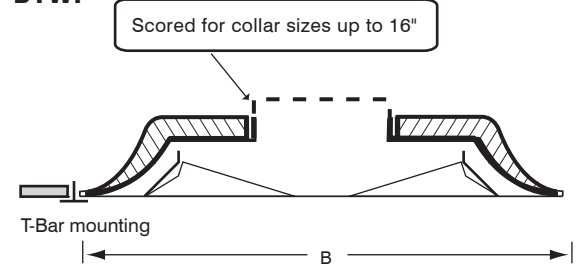
DTWI- R6 fiberglass insulation.

DTW Model #	Nominal Face Size	Actual Face Size B x B	Duct Size	Actual Neck Size
2406	24 x 24	23 ⁷ / ₈ x 23 ⁷ / ₈	6	5 ⁷ / ₈
2408	24 x 24	23 ⁷ / ₈ x 23 ⁷ / ₈	8	7 ⁷ / ₈
2410	24 x 24	23 ⁷ / ₈ x 23 ⁷ / ₈	10	9 ⁷ / ₈
2412	24 x 24	23 ⁷ / ₈ x 23 ⁷ / ₈	12	11 ⁷ / ₈
2414	24 x 24	23 ⁷ / ₈ x 23 ⁷ / ₈	14	13 ⁷ / ₈

DTW



DTWI



DSWI Model #	Nominal Face Size	Actual Face Size B x B
DTWI	24 x 24	23 ⁷ / ₈ x 23 ⁷ / ₈



DSWI fiberglass back.

All dimensions in inches

Twist Face Supply Diffuser Fixed face DTW Series

Size (in inches)	Neck Velocity (fpm)	400	500	600	700	800	1000	1100	1200	1400
	Velocity Pressure (in H ₂ O)	0.010	0.016	0.023	0.031	0.040	0.063	0.077	0.090	0.122
6	Total Pressure	0.012	0.018	0.025	0.034	0.044	0.069	0.082	0.098	0.033
	CFM	78	98	118	137	157	196	220	236	275
	Throw	1-1-2	1-2-3	1-2-4	1-2-5	2-3-7	2-3-8	2-4-9	3-4-9	3-6-10
	NC	<15	<15	<15	<15	<15	15	18	23	32
8	Total Pressure	0.016	0.027	0.036	0.049	0.063	0.096	0.118	0.144	0.186
	CFM	140	175	209	244	279	349	380	415	495
	Throw	1-2-4	2-3-5	2-3-7	3-4-8	3-4-9	4-5-10	4-6-11	4-7-12	5-8-12
	NC	<15	<15	<15	<15	<15	22	25	29	35
10	Total Pressure	0.023	0.035	0.051	0.067	0.087	0.132	0.161	0.197	0.244
	CFM	218	273	327	382	436	546	600	655	768
	Throw	2-3-7	3-4-8	3-5-8	4-5-9	4-6-10	5-7-13	5-7-14	6-7-14	7-8-15
	NC	<15	<15	<15	<15	16	23	26	30	38
12	Total Pressure	0.028	0.042	0.061	0.084	0.108	0.162	0.199	0.251	0.300
	CFM	314	393	470	550	628	785	865	990	1100
	Throw	3-4-9	3-5-10	4-6-11	5-7-13	5-8-13	7-9-14	7-9-15	8-11-16	10-13-18
	NC	<15	<15	<15	16	20	27	30	34	40
14	Total Pressure	0.033	0.053	0.073	0.099	0.125	0.190	0.234	0.272	0.367
	CFM	425	530	635	743	850	1057	1160	1268	1485
	Throw	3-6-11	5-7-13	6-9-14	7-10-15	8-11-16	10-13-17	11-14-18	11-14-19	12-15-21
	NC	<15	16	22	25	27	34	36	40	45

NC Noise Criteria Value based on 10 db room attenuation.

Throw Values are based on isothermal air and terminal velocities of 150 fpm 100 fpm, & 50 fpm respectively.

Total Pressure the sum of static pressure plus velocity pressure and is given in inches w.g.

HOW TO ORDER DSW

DTW-R4-W3 2408 /W

MODEL SERIES
 Standard Plaque DTW
 Insulated Plaque DTWI

FINISH (OPTIONAL)
 Standard is White /W
 See custom chart /C
 for more

INSULATION (OPTIONAL)
 Standard is uninsulated
 R4.2 Taped Insulation -R4
 R6 Taped Insulation -R6

NECK DIAMETER
 06-08-10-12-14"

FACE DIMENSIONS
 24" x 24" 24

DIRECTION (OPTIONAL)
 Standard is 4 Way -
 1 Way -W1
 2 Way Corner -WC
 2 Way Opposed -WO
 3 Way -W3

HOW TO ORDER DSWI

DSWI /W

MODEL SERIES
 Swirl Diffuser

DSWI

FINISH (OPTIONAL)
 Standard is White /W
 See chart for more

CEILING RETURNS



EGGCRATE-ER SERIES

Series **ER** grilles and registers have grid cores capable of transferring or returning high air volumes with minimum air pressure loss. They match in appearance grid louvers on luminaires. Models **ERT** - **ERU** - **ERN** fit lay-in tee bar openings in suspended grid ceilings. Model **ERI** comes with fibreglass back panel and Model **ERM** comes with a steel back panel. Both **ERI** and **ERM** fit lay-in tee bar openings. Model **ERE** is the matching return grille. It fits overlap openings in solid ceilings and walls.

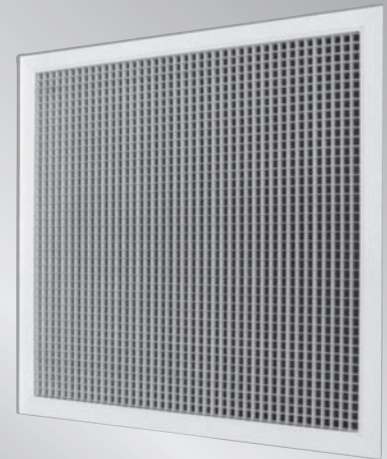
FEATURES

All Aluminium grilles

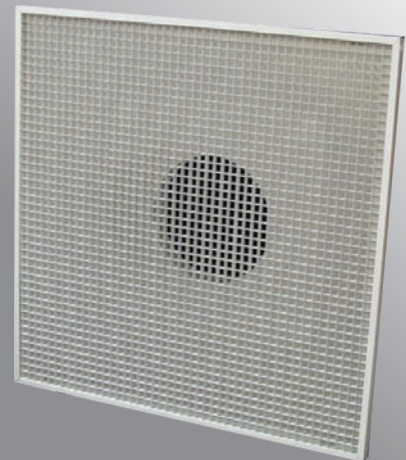
- Grid is $\frac{1}{2}'' \times \frac{1}{2}'' \times \frac{1}{2}''$.
- Frame is of extruded aluminium.
- Suitable for T-bar installations (Overall size = Listed size - $\frac{1}{4}''$).
 Model **ERT** (fig. 1) with $1\frac{1}{4}''$ wide "L" frame.
 Model **ERU** (fig. 2) with "U" frame.
 Model **ERN** (fig. 3) $\frac{1}{2}'' \times \frac{1}{2}'' \times \frac{1}{2}''$. Aluminium core only.
 Custom Sizing Available.
 Model **ERN1** (fig. 3) $\frac{1}{2}'' \times \frac{1}{2}'' \times 1''$. Model **ERN111** (fig. 3) $1'' \times 1'' \times 1''$. Aluminium core only. Fixed Sizes Only.
 Model **ERI** (fig. 4) aluminium core with molded fiberglass back and aluminium foil vapor barrier scored for 6" to 14" D.
 Model **ERM** (fig. 5) aluminium core with steel back panel.
- Suitable also for overlap installations, including drywall. (Collar size = Listed duct size - $\frac{1}{4}''$).
 Model **ERE** return grille (fig. 6) with $1\frac{1}{4}''$ wide margin has countersunk mounting screw holes as standard feature. (Screws are provided).
 Model **ERE** return grille is available with plaster frame (**ERE-F**) for use as plaster stop or as separate frame to facilitate grille removal.

Plastic grilles

- Model **ERN-P** (fig. 3) with plastic core.
- Grid is $\frac{1}{2}'' \times \frac{1}{2}'' \times \frac{3}{8}''$.
- Standard grille and panel sizes:
 24" x 12" / 24" x 24" / 24" x 48".
 Other sizes are available in one piece up to 48" x 24".



ERT



ERM

Available Dimensions:
ERT, ERU, ERN, ERE

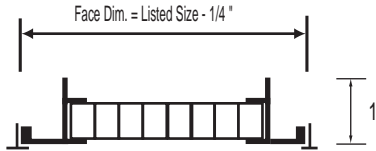
MIN. W X H	MAX. W X H
6" x 4"	Any even dimension up to 48" x 24"
2" increments of width and height.	
Multiple sections furnished for sizes greater than maximum width and height.	

DATA SHEET

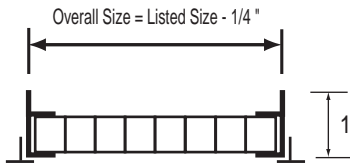
Installation Options

T-BAR INSTALLATIONS

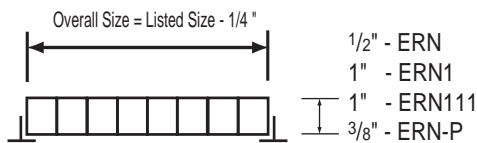
Model ERT
(With "L" frame)
Fig. 1



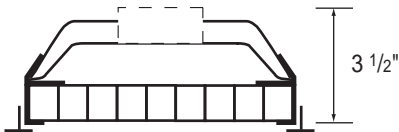
Model ERU
(with "U" frame)
Fig. 2



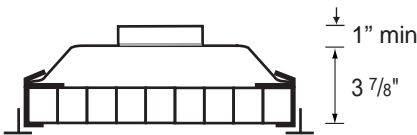
Model ERN, ERN1,
& ERN111 Aluminium
Model ERN-P Plastic
(Core only)
Fig. 3



Model ERI
(w/ fibreglass back panel)
Fig. 4

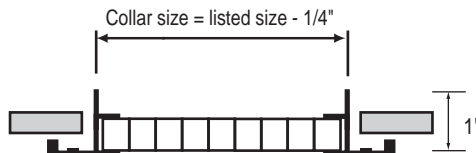


Model ERM
(w/ steel back panel)
Fig. 5



DRY WALL AND SURFACE MOUNT INSTALLATIONS

Model ERE (Return
Grille)
(Overlap frame)
Fig. 6



ENGINEERING PERFORMANCE DATA

ER SERIES

RETURN GRILLES AIRVECTOR®

		NC 20-25 Application Non-Ducted		NC 25-30 Application Ducted		NC 30-40 Application Ducted	
		Ps		Ps		Ps	
Listed Size W x H (inches)	Ak	-0.02"	-0.03"	-0.08"	-0.10"	-0.15"	-0.20"
		CFM	CFM	CFM	CFM	CFM	CFM
10 x 6 12 x 6 10 x 8 12 x 8	.42 .50 .53 .63	140 170 195 235	170 210 240 290	280 340 390 475	315 380 440 530	385 465 535 645	445 535 615 745
10 x 10 18 x 6 12 x 12 18 x 12	.64 .75 .89 1.3	245 260 370 575	305 320 455 710	500 525 745 1155	560 590 835 1295	685 720 1020 1580	790 830 1170 1820
22 x 10 24 x 12 18 x 18 30 x 12	1.4 1.7 1.9 2.2	630 770 890 985	775 945 1095 1210	1260 1540 1785 1950	1410 1725 2000 2180	1720 2100 2440 2660	1980 2420 2780 3060
24 x 18 36 x 12 22 x 22 30 x 18	2.5 2.7 2.8 3.2	1200 1290 1340 1535	1470 1590 1650 1890	2400 2600 2700 3090	2690 2910 3020 3450 3280	3550 3680 4210	3770 4100 4240 4850
24 x 24 36 x 18 30 x 24 34 x 22	3.3 3.8 4.1 4.3	1620 1830 2040 2170	1990 2250 2510 2670	3250 3670 4100 4360	3640 4110 4590 4875	4440 5020 5600 5950	5125 5775 6450 6860
36 x 24 36 x 30 34 x 34 48 x 24	4.9 6.1 6.3 6.6	2470 3120 3190 3340	3040 3840 3930 4100	4960 6275 6425 6700	5550 7040 7200 7500	7650 8575 8775 9150	7775 9900 10100 10500
48 x 30 48 x 36 46 x 46	8.1 9.7 11.6	4190 5060 6100	5150 6240 7475	8400 10200 12200	9400 11400 13700	11425 13925 16700	13150 16100 19300

HOW TO ORDER

EXAMPLE :

ERT 2412

T for T-bar with "L" frame

U for T-bar with "U" frame

N, N1, N111 for

Aluminium core only

N-P for Plastic core only

M for steel back panel

E for Drywall

E-F with plaster frame

I for R6 Insulated back

Listed
size

EGG CRATE FILTER GRILLES



MODELS ERMF-ERIF-ERTF FOR TEE BAR LAY-IN INSTALLATIONS

Series **ER** filter grilles have grid cores capable of transferring or returning high air volumes with minimum air pressure loss. They match in appearance grid louvers on luminaries.

The core consists of a 1/2" x 1/2" x 1/2" aluminum grid in a sturdy extruded aluminum U frame which swings in or out of the fixed back pan for easy access to the 1" standard filter or filter media (supplied by others). Two locking arms opposite to the two concealed hinges provide secure locking of the core in an unobtrusive manner.

Model **ERMF** has steel back pan with heavy gauge steel reinforcing corners equivalent to 18 ga. so as to minimize damage due to handling.

Model **ERIF** has an insulated back pan consisting of a fixed extruded aluminum frame and a molded fiberglass pan suitable for round duct connections up to 14" D. and scored for easy cutting of collar opening. This model has all aluminum metal components with sturdy corners so as to minimize damage due to handling.

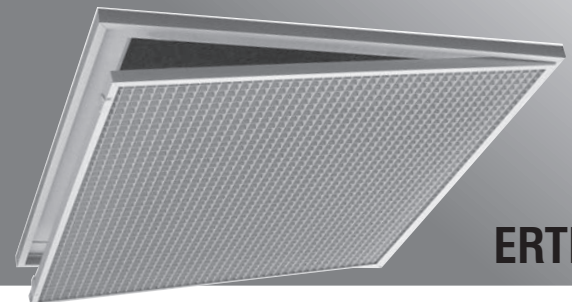
Model **ERTF** has a square filter frame to accommodate 20" x 20" filters and ducts of the same listed size. This model has sturdy corners so as to minimize damage due to handling.



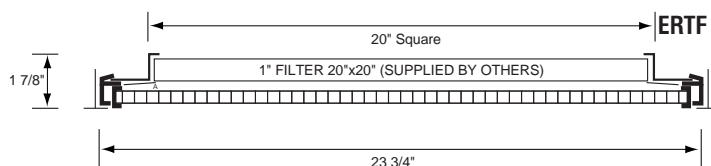
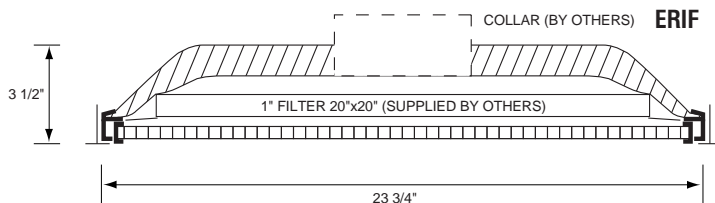
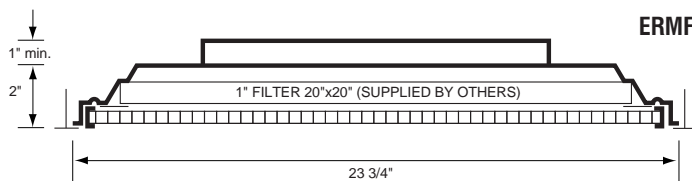
ERMF



ERIF



ERTF



PLASTIC EGG CRATES

All grilles are available with plastic core. Please specify by adding suffix "P". Example: ERMF-P, ERIF-P, ERTF-P etc. Plastic grid is 1/2" x 1/2" x 3/8".

HOW TO ORDER

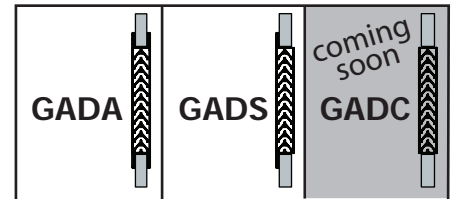
M For metal back pan
I For molded f. glass back pan
T For rectangular duct connection

ERMF-P 24 08
 Collar Size
 24" x 24" Face Size
 For plastic core add suffix "P"

DATA SHEET

Aluminum Door Grille - Model GADA, GADS and GADC

Size (Inches)	Ak	Velocity (FPM)							
			200	300	400	500	600	700	800
8 x 8	.44	CFM	90	130	180	220	265	310	350
		NC	.17	.22	.25	.29	.32	.34	.37
14 x 6	.55	CFM	110	165	220	275	330	385	440
		NC	.18	.23	.26	.30	.36	.39	.41
12 x 8	.64	CFM	130	190	255	320	385	450	510
		NC	.19	.24	.27	.30	.34	.37	.40
14 x 8	.74	CFM	150	220	295	370	445	520	590
		NC	.20	.24	.28	.31	.35	.37	.41
20 x 6	.78	CFM	155	235	310	390	470	545	625
		NC	.20	.24	.28	.32	.34	.38	.40
12 x 12	.93	CFM	185	280	370	465	560	650	745
		NC	.21	.25	.29	.32	.35	.38	.40
30 x 6	1.12	CFM	225	335	450	560	670	785	895
		NC	.21	.35	.29	.32	.35	.38	.41
16 x 12	1.19	CFM	240	360	475	595	715	835	950
		NC	.22	.26	.30	.33	.36	.39	.42
18 x 12	1.33	CFM	265	400	530	665	800	930	1065
		NC	.23	.27	.31	.34	.37	.40	.42
20 x 12	1.46	CFM	290	440	585	730	875	1020	1170
		NC	.23	.27	.31	.34	.37	.40	.43
16 x 16	1.54	CFM	310	460	615	770	925	1080	1230
		NC	.23	.28	.31	.35	.38	.40	.43
24 x 12	1.75	CFM	350	525	700	875	1050	1225	1400
		NC	.24	.28	.32	.35	.38	.41	.43
18 x 18	1.95	CFM	390	585	780	975	1170	1365	1560
		NC	.24	.39	.32	.36	.39	.41	.44
30 x 12	2.17	CFM	435	650	870	1085	1300	1520	1740
		NC	.25	.29	.33	.36	.39	.42	.44
20 x 20	2.42	CFM	485	730	970	1210	1450	1690	1940
		NC	.25	.30	.33	.36	.39	.42	.45
24 x 18	2.55	CFM	510	765	1020	1275	1530	1785	2040
		NC	.26	.30	.34	.37	.40	.43	.46
30 x 18	3.23	CFM	650	970	1290	1620	1940	2260	2580
		NC	.25	.30	.33	.37	.40	.43	.45
24 x 24	3.40	CFM	680	1020	1360	1700	2040	2380	2720
		NC	.27	.31	.35	.38	.41	.44	.46
30 x 24	4.18	CFM	840	1250	1670	2090	2510	2930	3340
		NC	.28	.32	.36	.39	.42	.45	.47
30 x 30	5.15	CFM	1030	1550	2580	3090	3610	4120	
		NC	.29	.33	.37	.40	.43	.46	.48


NOTE:

Ak: outlet area in Sq. feet.
NC: Noise Criteria

TRANSFER GRILLE



Rev. 0

MODEL GATS, GATA, GATD ACOUSTIC TRANSFER GRILLE

MODEL **GATS** - Acoustic transfer grille

MODEL **GATA** - Acoustic transfer grille for variable depth partition of 1 1/2" to 4" with rear matching frame.

MODEL **GATD** - Back to back acoustic transfer grille

The Airvector® **GATS** is a sleek solution designed for noise reduction and ventilation air transfer requirements in various architectural settings. Engineered to minimize noise transfer or "cross-talk" while facilitating seamless air circulation, the **GATS** boasts high-quality aluminum construction with channel section cores forming a labyrinth airway. Internally lined with acoustic damping media, these cores ensure effective sound absorption. The grille is encased within a sturdy flanged frame equipped with a sealing gasket for optimal performance. **GATS** units are supplied with fixed borders and matching adjustable rear border frames for ease of installation and versatility.

GATS units surpass standard air openings in providing significant acoustic isolation improvements, making them indispensable for environments where noise control is critical. Multiple **GATS** units can be installed in series to further enhance transmission loss.

- Easy to install
- Suitable for partition, wall or door mounting
- Fits most standard doors and partitions
- Easy to clean
- Powder paint coating - White (default) Custom colours avail.

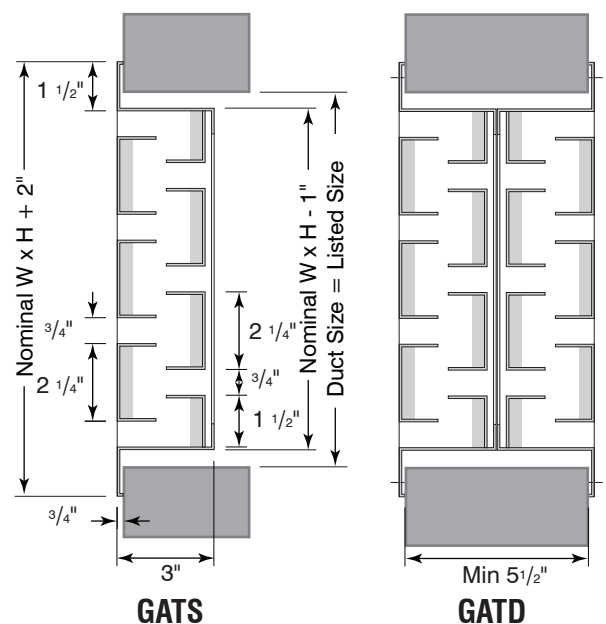
Sizes:

Width 6" minimum to 41" maximum.

Height 5" minimum to 41" maximum in 3" increments.

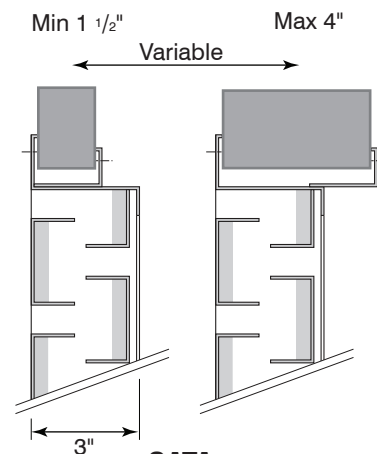


GATS



GATS

GATD



GATA

Door / Partition mounting 1 1/2" - 4" thick

Free Area
25%

ENGINEERING PERFORMANCE DATA

SUPPLY AIR GRILLES AND REGISTERS

Curved blade grilles - Series GCB10, GCB20, GCB30 & GCB40



TABLE 1

Nominal Duct Size	Face Vel. (fpm)		100	200	300	400	500	600	700	800	900	1000	
	Vel. Pressure		0.001	0.002	0.006	0.010	0.016	0.022	0.031	0.040	0.051	0.062	
	Tot. Pressure		0.003	0.014	0.031	0.056	0.090	0.131	0.175	0.225	0.290	0.355	
6x4	CFM					50	60	70	85	95	110	120	
	Throw	2-Way				5-8-13	7-9-12	8-12-19	9-13-18	10-15-21	12-17-24	13-19-31	
		1-Way				7-10-16	8-11-15	10-13-19	11-16-23	12-18-26	14-21-34	15-23-37	
	NC					14	20	24	28	32	35	38	
8x4	CFM				50	65	80	95	110	130	145	160	
	Throw	2-Way			5-7-11	6-9-14	7-11-17	9-13-21	10-14-20	11-16-23	12-18-26	14-21-33	
		1-Way				5-8-13	7-11-17	9-13-21	10-15-21	12-17-25	13-20-32	15-22-36	17-25-40
	NC				<	15	21	26	30	33	36	39	
6x6 10x4	CFM				60	80	100	120	140	160	180	200	
	Throw	4-Way			4-6-9	5-8-13	6-9-15	8-11-18	9-13-21	1-14-20	11-16-23	12-17-25	
		3-Way				4-6-10	6-9-14	7-1-16	8-12-20	1-13-19	11-15-22	12-17-25	13-20-32
		2-Way				5-7-11	6-9-15	8-11-18	9-14-22	1-15-21	12-17-25	13-20-32	15-22-35
		1-Way				6-9-14	8-11-18	9-14-22	11-15-22	12-18-26	14-21-34	16-24-38	18-26-42
NC				<	16	22	27	31	34	37	40		
8x6 12x4	CFM			50	80	105	130	155	180	210	235	260	
	Throw	4-Way		3-4-7	4-5-6	6-9-14	7-1-16	8-12-20	1-13-19	11-15-22	12-17-25	13-20-32	
		3-Way		3-4-7	5-6-7	6-9-15	8-11-18	9-13-21	1-14-20	11-16-23	13-19-31	14-21-34	
		2-Way		3-5-8	5-6-8	7-9-12	8-12-20	1-14-20	11-16-23	13-19-31	14-21-34	16-24-38	
		1-Way		4-5-6	6-8-11	8-11-15	1-14-20	12-17-24	13-20-32	15-23-37	17-26-41	19-28-45	
NC			<	10	17	23	28	32	35	38	41		
14x4	CFM			60	90	120	150	180	210	240	270	300	
	Throw	4-Way		3-4-7	4-5-6	6/8/10	7/10/13	9/12/17	10/14/20	11/16/23	12/18/26	14-21-33	
		3-Way		3-5-8	5-6-7	6/9/15	8/11/15	9/13/18	10/15/21	12/17/25	13-20-32	15-22-35	
		2-Way		3-5-8	5-7-9	7/10/13	9/12/17	10/14/20	12/17/24	13-20-32	16-24-38	16-24-39	
		1-Way		4-5-6	6/8/11	8/11/16	10/15/21	12/17/25	14-21-34	16-24-38	18-27-43	20-29-47	
NC			<	10	18	23	28	32	36	39	42		
8x8 10x6 16x4	CFM			70	105	140	175	210	245	280	315	350	
	Throw	4-Way		3-4-7	5-7-11	6-9-15	8-11-18	9-13-21	1-15-21	12-17-24	13-19-31	14-21-34	
		3-Way		3-5-8	5-7-12	6-9-15	8-12-19	1-13-19	11-15-22	14-19-30	14-21-33	15-23-37	
		2-Way		4-6-9	5-8-13	7-1-13	9-13-21	1-15-21	12-17-25	14-21-33	15-23-37	17-26-41	
		1-Way		4-5-6	7-9-12	9-12-17	1-15-21	12-18-26	15-22-35	17-25-40	18-27-44	20-31-49	
NC			<	11	18	24	29	33	37	39	42		
12x6 18x4	CFM			80	120	160	200	240	280	320	360	400	
	Throw	4-Way		3-5-8	5-6-7	6-8-11	8-11-15	9-13-18	11-15-22	12-17-25	13-20-32	15-22-35	
		3-Way		3-5-8	5-6-8	7-9-12	8-11-16	1-14-20	11-16-20	13-19-31	15-22-35	16-24-38	
		2-Way		4-6-9	6-8-10	8-1-14	9-13-18	11-15-22	12-18-26	14-21-34	16-24-38	18-26-42	
		1-Way		5-6-7	7-9-12	9-13-18	11-15-22	13-19-31	15-22-36	17-26-41	19-29-46	21-32-51	
NC				12	19	25	30	34	37	40	43		
10x8 14x6	CFM			90	135	180	225	270	315	360	405	450	
	Throw	4-Way		3-5-8	5-6-8	6-9-15	8-12-19	1-13-19	11-15-22	12-18-26	14-21-33	15-23-37	
		3-Way		3-5-8	5-7-9	7-11-17	9-13-21	1-14-20	12-17-24	13-20-32	15-22-36	16-24-39	
		2-Way		4-6-9	6-8-10	8-12-19	1-13-19	11-16-23	13-19-31	15-22-35	16-24-39	18-27-44	
		1-Way		5-7-11	7-11-17	9-14-22	11-16-23	13-20-32	15-23-37	18-26-42	20-29-47	22-33-53	
NC			<	12	19	26	30	34	38	41	44		
12x8 16x6 24x4	CFM			55	110	165	220	275	330	385	440	495	550
	Throw	4-Way		2-3-4	3-5-8	5-7-12	7-1-16	8-12-20	1-14-20	12-17-24	13-19-31	15-22-35	16-24-39
		3-Way		2-3-5	4-6-9	5-8-13	8-11-18	9-14-22	11-15-22	12-18-26	14-21-33	16-24-38	17-26-41
		2-Way		2-3-5	4-6-10	6-9-15	8-12-20	1-14-20	12-17-25	14-21-33	15-23-37	17-26-41	19-29-46
		1-Way		2-4-6	5-7-12	8-11-18	1-13-19	12-17-25	14-21-34	16-24-39	18-27-44	21-31-50	23-35-56
NC			<	<	13	20	26	31	35	39	41	44	
10x10 18x6	CFM			60	125	185	250	310	370	435	495	560	620
	Throw	4-Way		2-3-4	4-6-9	5-8-13	7-11-17	9-13-21	1-15-21	12-17-24	13-20-32	15-22-36	17-25-40
		3-Way		2-3-5	4-6-9	6-9-14	8-11-18	9-14-22	11-16-23	13-19-31	14-21-34	16-24-39	18-27-43
		2-Way		2-3-5	4-6-10	6-9-15	8-12-20	1-16-25	12-17-25	14-21-34	16-24-38	18-27-43	20-29-47
		1-Way		2-3-6	5-7-12	8-11-18	1-14-20	12-19-30	15-22-35	17-26-41	19-29-46	21-32-51	24-36-57
NC			<	<	13	21	27	32	36	39	42	45	

ENGINEERING PERFORMANCE DATA

SUPPLY AIR GRILLES AND REGISTERS

Curved blade grilles - Series GCB10, GCB20, GCB30 & GCB40



Nominal Duct Size	Face Vel. (fpm)	100	200	300	400	500	600	700	800	900	1000	
	Vel. Pressure	0.001	0.002	0.006	0.010	0.016	0.022	0.031	0.040	0.051	0.062	
	Tot. Pressure	0.003	0.014	0.031	0.056	0.090	0.131	0.175	0.225	0.290	0.355	
30x4 20x6 14x8 12x10	CFM	70	140	210	280	350	420	490	550	630	700	
	Throw	4-Way	2-3-5	4-6-9	5-8-13	7-11-17	9-13-21	10/15/21	12-17-25	14-21-33	15-23-37	17-26-41
		3-Way	2-3-5	4-6-9	6-9-14	8-12-19	10/13/19	11-16-23	13-20-32	15-22-36	17-25-40	18-27-44
		2-Way	2-4-6	5-7-11	7/10/16	9-13-21	10/15/21	12/18/26	15-22-35	17-25-40	18-27-44	20-31-49
		1-Way	3-4-7	5-8-13	8-12-19	10/15/21	12-19-30	15-22-36	18-26-42	20-29-47	22-33-53	25-37-59
NC	-	-	14	21	27	32	36	40	42	45		
36x4 24x6 16x8 14x10	CFM	80	160	245	325	405	485	565	650	730	810	
	Throw	4-Way	2-3-5	4-6-9	6-9-14	8-11-18	9-14-22	11-15-22	12-18-26	14-21-34	16-24-38	18-27-43
		5-Way	2-3-5	4-6-10	6-9-15	8-12-20	11-15-22	12-17-24	14-21-33	15-23-37	17-26-41	19-29-46
		2-Way	2-4-6	5-7-11	7-1-16	9-14-22	11-15-22	13-19-31	15-22-36	17-26-41	19-29-46	21-32-51
		1-Way	3-4-7	5-8-13	8-12-20	11-15-22	13-20-32	16-24-38	18-27-44	20-31-49	23-34-55	26-39-62
NC	-	-	15	22	28	33	37	40	43	46		
24x8 18x15 16x12	CFM	85	175	260	350	435	520	610	695	785	870	
	Throw	4-Way	2-3-5	4-6-9	6-9-14	8-12-19	1-13-19	11-16-23	13-19-31	15-22-35	16-24-39	18-27-43
		3-Way	2-3-5	4-6-10	6-9-15	8-12-20	1-15-21	12-17-25	14-21-33	16-24-38	18-26-42	20-29-47
		2-Way	2-4-6	5-7-11	7-11-17	9-14-22	11-16-23	13-20-32	15-23-37	18-26-42	20-29-47	22-32-52
		1-Way	3-4-7	6-9-14	8-12-20	11-15-22	13-20-32	16-24-39	19-28-45	21-31-50	23-35-56	26-39-63
NC	-	-	15	22	28	33	37	40	43	46		
30x6 20x8 16x10 14x12	CFM	100	205	305	410	510	610	715	815	920	1020	
	Throw	4-Way	2-3-5	4-6-10	6-9-15	8-12-19	1-14-20	12-17-24	13-20-32	15-22-36	17-26-41	19-28-45
		5-Way	2-4-6	4-6-10	7-1-16	9-13-21	1-16-25	12-18-26	15-22-35	16-24-39	18-27-44	20-30-48
		2-Way	2-4-6	5-7-12	7-11-17	1-13-19	12-17-24	14-21-33	16-24-39	18-27-43	20-31-49	23-34-55
		1-Way	3-4-7	6-9-14	9-13-21	11-17-27	14-21-34	17-25-40	19-29-46	22-32-52	25-37-59	27-41-65
NC	-	-	16	23	29	34	38	41	44	47		
24x8 18x10 16x12	CFM	115	230	345	460	575	690	805	920	1040	1150	
	Throw	4-Way	2-3-5	4-6-10	5-9-15	8-12-20	1-15-21	12-17-25	14-21-33	16-24-38	18-26-42	19-29-46
		3-Way	2-4-6	5-7-11	7-1-16	9-13-21	11-15-22	13-19-31	15-22-36	17-26-41	19-28-45	21-31-50
		2-Way	2-4-6	5-7-12	8-11-18	1-13-19	12-17-25	14-21-24	17-25-40	19-28-45	21-31-50	23-35-56
		1-Way	3-5-8	6-9-15	9-14-22	12-17-24	15-22-35	17-26-41	20-29-47	22-34-54	25-27-60	28-42-68
NC	-	-	16	24	30	34	38	42	45	48		
36x6 20x10 14x14	CFM	125	250	375	500	625	750	875	1000	1120	1250	
	Throw	4-Way	2-3-5	4-5-6	6-8-11	8-12-20	1-15-21	12-17-25	14-21-34	16-24-38	18-27-43	20-29-47
		3-Way	2-4-6	5-6-7	7-9-12	9-14-22	11-16-23	13-20-32	15-23-37	17-26-41	19-29-46	21-32-51
		2-Way	2-4-6	5-6-8	8-1-14	1-14-20	12-18-26	15-22-35	17-26-41	19-29-46	21-32-51	24-36-57
		1-Way	3-5-8	6-8-11	9-13-18	12-17-25	15-22-35	18-26-42	20-30-48	23-34-55	26-39-62	29-43-69
NC	-	-	16	24	30	35	39	42	45	48		
16x14 18x12	CFM	135	270	405	540	675	810	945	1080	1220	1350	
	Throw	4-Way	2-4-6	4-5-6	7-1-16	9-13-21	1-15-21	12-18-26	15-22-35	16-24-39	18-27-43	20-30-48
		3-Way	2-4-6	5-6-7	7-11-17	9-14-22	11-16-23	13-20-32	15-23-37	18-26-42	20-29-47	22-32-52
		2-Way	3-4-7	5-7-9	8-12-19	1-15-21	12-18-26	15-22-36	18-26-42	20-29-47	22-33-53	25-37-59
		1-Way	3-5-8	6-8-11	10-13-19	12-17-25	15-22-36	18-27-43	21-31-50	23-35-56	26-39-63	29-44-70
NC	-	-	17	24	30	35	39	42	45	48		
30x8 24x10 20x12 18x14 16x6	CFM	155	305	460	610	765	920	1070	1220	1380	1530	
	Throw	4-Way	2-4-6	5-6-7	7-1-16	9-13-21	11-15-22	13-19-31	15-22-36	17-25-40	19-28-45	21-31-50
		3-Way	2-4-6	5-6-8	7-11-17	10-13-19	12-17-24	14-21-33	16-24-39	18-27-44	20-31-49	22-34-54
		2-Way	3-4-7	5-7-9	8-12-19	10-15-21	13-20-32	15-23-37	18-27-43	20-30-48	23-34-55	25-37-60
		1-Way	3-5-8	7-9-12	10-13-19	12-18-26	15-23-37	18-27-44	21-32-51	24-36-58	27-41-65	30-46-73
NC	-	-	17	25	31	36	40	43	46	49		
36x8 30x10 24x12 20x14 18x16	CFM	182	365	545	730	910	1090	1270	1460	1640	1820	
	Throw	4-Way	2-4-6	5-6-7	7-11-17	9-14-22	11-16-23	13-20-32	15-23-37	18-26-42	20-29-47	22-33-53
		3-Way	2-4-6	5-6-8	8-11-18	10-14-20	12-17-25	15-22-35	17-25-40	19-28-45	21-32-51	24-36-57
		2-Way	3-4-7	6-8-10	8-12-20	11-16-23	14-21-33	16-24-39	19-28-45	21-31-50	24-36-57	26-39-63
		1-Way	3-5-8	7-9-12	10-14-20	13-20-32	16-24-39	19-29-46	22-34-54	25-37-60	29-42-68	32-48-76
NC	-	-	18	26	32	36	40	44	47	50		
24x14 20x16 18x18	CFM	210	420	630	840	1050	1260	1470	1680	1890	2100	
	Throw	4-Way	2-4-6	5-6-8	8-11-18	10-13-19	12-17-24	14-21-34	16-24-39	18-27-44	20-31-49	23-34-55
		3-Way	3-4-7	5-7-9	8-12-19	10-15-21	12-18-26	15-22-36	18-26-42	20-29-47	22-33-53	25-37-59
		2-Way	3-4-7	6-8-10	9-13-21	12-17-24	14-21-34	17-25-40	19-29-46	22-32-52	25-37-59	28-41-66
		1-Way	4-6-9	7-10-13	10-15-21	14-21-33	17-25-40	20-30-48	23-34-55	25-39-62	29-44-70	33-50-80
NC	-	-	19	26	32	37	41	44	47	50		

GRILLES



Rev. 0

ALUMINUM

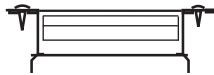
MODELS GDA1 supply, single deflection spiral duct grille
 GDA2 supply, double deflection spiral duct grille



GDA20

Fastening Methods

Air Scoop: For grilles with air scoop, add suffix 8



Screw holes

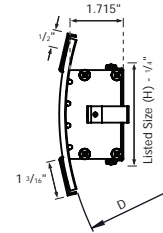
Single deflection supply spiral duct grilles are recommended for applications requiring pattern adjustability in a horizontal plane.

Double-deflection supply spiral duct grilles are recommended for application in systems requiring optimum flexibility of pattern changes to accommodate changing job conditions.

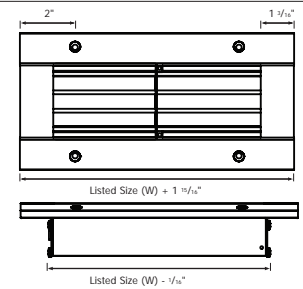
The combination of streamlined foil shaped bars and 17 mm (2/3 inch) bar spacing maintains a high effective area capacity of greater than 80% which minimizes outlet velocity, reduces pressure drop and assures quiet operation. Individually adjustable bars are capable of shortening throw up to one-half with a wide spread deflection requiring only a 20% increase in outlet velocity at a fixed volume.

GDA Series have extruded aluminum frames and bars which follow the curve on the face of the grille.

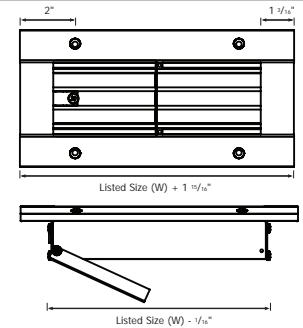
Dimensions



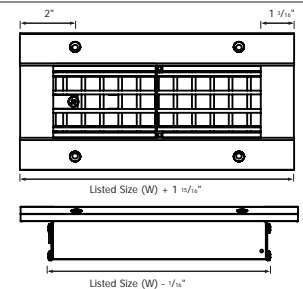
GDA10



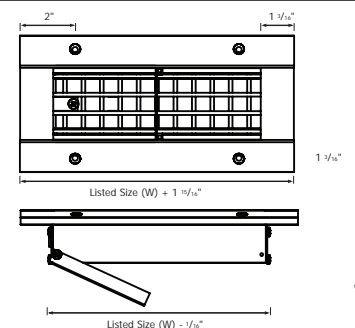
GDA18



GDA20



GDA28



HOW TO ORDER GDA SERIES

GDA28-D14 1006 /W

<p>MODEL SERIES Alum Spiral Duct Grille GDA</p> <p>AIR PATTERN Single Deflection 1 Double Deflection 2</p> <p>GRILLE/AIR SCOOP Grille Only 0 Grille with Air Scoop 8</p>	<p>DUCT DIMENSION Duct Diameter -D##</p> <p>WIDTH (INCHES) 14</p> <p>HEIGHT (INCHES) 1006</p> <p>FINISH /W White (Default)</p>
--	--

MAX. LISTED SIZE: 36"x12"
FINISH: Powder baked enamel paint for durability. Default is White. Other finishes available (see chart for more).

DATA SHEET

Spiral Duct Grilles

Single and Double Deflection Adjustable - GDA Series

TABLE 1

LISTED HEIGHT				Outlet Velocity 450-600 FPM				Outlet Velocity 550-700 FPM				Outlet Velocity 600-800 FPM				Outlet Velocity 700-1000 FPM				NC 15				
				Deflection				Deflection				Deflection				Deflection								
				0° 22° 42° 55°				0° 22° 42° 55°				0° 22° 42° 55°				0° 22° 42° 55°								
				V _K				V _K				V _K				V _K								
				CFM				CFM				CFM				CFM								
4 5 6 8 10 12				450 500 550 600				550 600 650 700				600 700 750 800				700 800 900 1000								
				P _T				P _T				P _T				P _T								
				.01 .01 .02 .02				.02 .02 .03 .03				.02 .03 .04 .04				.03 .04 .05 .06								
				Throw (T) V _T 75				Throw (T) V _T 75				Throw (T) V _T 75				Throw (T) V _T 75								
LISTED WIDTH																				NC 30				
6 5				40	6	5	4	3	45	8	7	6	4	60	10	9	7	5	65		11	10	8	6
8 6				50	7	6	5	4	60	9	11	6	5	70	11	10	8	6	80		12	11	9	7
10 8 6				75	9	7	6	5	90	10	9	7	6	100	12	11	9	7	125		13	12	10	8
12 10 8				100	10	8	6	5	125	11	9	8	7	150	13	12	9	8	175		14	13	11	8
14 12 10 8				125	11	9	7	6	150	12	11	9	7	175	14	13	10	8	200	16	14	11	9	
18 14 12				150	11	10	8	7	175	13	11	10	8	200	15	14	11	9	250	17	15	12	10	
20 16 14 10				175	12	11	9	7	200	15	13	11	9	250	17	15	12	9	275	19	17	14	11	
24 20 16 12 10				225	13	12	10	8	275	16	14	12	10	300	19	16	13	10	350	21	18	15	12	
30 24 20 14 12				300	14	13	11	9	350	18	15	13	10	425	20	17	15	11	475	24	20	17	13	
30 24 18 14 12				350	17	14	12	9	425	20	17	13	11	500	22	20	17	12	550	26	22	18	14	
26 20 16 14				400	18	16	13	10	475	21	18	15	12	550	24	21	18	13	650	28	24	20	15	
30 24 18 16				450	19	17	13	11	550	22	19	17	13	625	26	22	19	14	725	30	25	22	17	
26 22 18				500	20	17	14	12	600	24	20	18	13	700	27	24	20	15	800	32	27	23	18	
30 24 20				600	21	18	15	12	700	25	22	18	14	850	29	25	22	16	950	34	29	25	19	
30 24				700	23	20	17	13	850	28	24	20	15	975	33	28	24	18	1125	37	31	27	21	
28				800	25	21	18	14	950	31	26	22	17	1125	35	30	26	20	1275	39	34	29	22	
30				900	27	22	19	15	1100	32	27	23	18	1250	36	31	27	21	1450	42	36	31	23	
				1000	29	25	21	16	1200	34	29	25	19	1400	40	34	29	22	1600	45	39	34	25	

SYMBOLS

V_T Terminal Velocity in fpm
 V_R Room Velocity in fpm
 V_K Outlet Velocity in fpm

A_K Outlet area in Sq. Feet
 P_T Total Pressure H₂O
 P_S Static Pressure H₂O

NC Re 8db Room attenuation
 T Throw in feet at X and Y

Spiral Duct Grilles

Single and Double Deflection Adjustable - GDA Series

AIR PATTERN SETTINGS

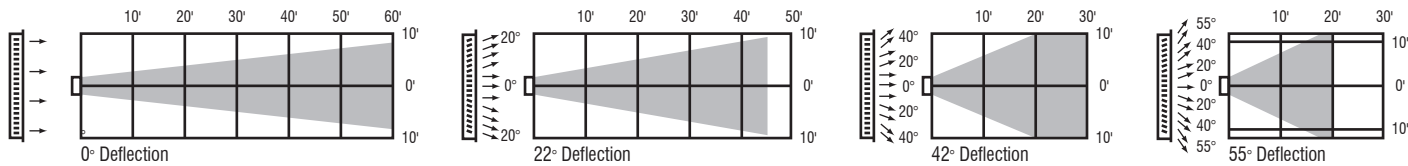


TABLE 1 (Cont'd)

LISTED HEIGHT		Outlet Velocity 900-1200 FPM				Outlet Velocity 1100-1450 FPM				Outlet Velocity 1250-1700 FPM				Outlet Velocity 1450-1900 FPM									
		CFM		Deflection		CFM		Deflection		CFM		Deflection		CFM		Deflection							
				0°	20°			40°	55°			0°	20°			40°	55°	0°	20°	40°	55°		
		V _k		V _k		V _k		V _k		V _k		V _k		V _k									
		900		1000		1100		1200		1300		1450		1250		1400		1550		1700			
P _r		P _r		P _r		P _r		P _r		P _r		P _r		P _r		P _r		P _r					
.05		.06		.08		.09		.08		.09		.10		.13		.09		.12		.15		.18	
Throw (T) V _r 75		Throw (T) V _r 75		Throw (T) V _r 75		Throw (T) V _r 75		Throw (T) V _r 75		Throw (T) V _r 75		Throw (T) V _r 75		Throw (T) V _r 75		Throw (T) V _r 75		Throw (T) V _r 75		Throw (T) V _r 75			
LISTED WIDTH	6	5	80	13	11	9	7	100	15	13	11	8	125	19	16	13	10	150	22	19	15	12	
	8	6	100	15	13	11	8	125	18	15	13	10	150	21	18	14	11	175	25	21	17	13	
	10	8	150	17	14	12	9	175	20	17	14	11	200	24	20	17	13	225	27	23	19	15	
	12	10	200	18	15	13	10	250	22	19	15	12	275	25	21	18	14	325	29	25	21	17	
	14	12	250	21	18	15	11	300	15	21	18	14	350	28	25	20	15	400	33	28	24	18	
	18	14	300	24	20	16	13	350	27	24	20	15	425	31	27	22	17	475	36	32	26	20	
	20	16	350	25	21	18	14	425	30	25	21	17	500	34	30	25	19	550	39	32	27	21	
	24	20	450	27	23	19	15	550	32	28	24	18	625	37	32	27	22	725	42	36	31	24	
	30	24	600	29	25	21	16	725	35	30	26	20	850	41	35	30	23	950	45	40	34	26	
	38	30	700	32	28	24	18	850	39	33	28	21	975	45	39	33	25	1125	49	43	38	28	
	40	26	800	34	30	25	19	950	41	35	30	22	1125	48	41	35	27	1275	52	46	40	31	
		30	900	36	31	26	20	1075	43	37	32	24	1250	51	43	37	28	1450	55	49	42	32	
		26	1000	39	33	28	22	1200	45	40	34	26	1400	53	45	39	30	1600	58	51	44	34	
		30	1200	42	36	31	24	1450	48	42	36	28	1675	57	48	42	32	1925	61	54	46	36	
		30	1400	45	39	34	26	1675	52	45	40	31	1950	60	51	45	35	2250	58	49	40	38	
		28	1600	47	43	37	28	1925	56	48	43	34	2250	54	47	39	37	2500	62	53	43	40	
		30	1800	49	44	40	31	2150	59	51	46	35	2500	57	50	41	39	2750	56	46	46	42	
			2000	52	47	42	32	2400	54	49	43	38	2800	61	53	43	41	3200	59	49	48	44	

NC 35

NC 45

Spiral Duct Grilles

Single and Double Deflection Adjustable - GDA Series

THROW FACTORS

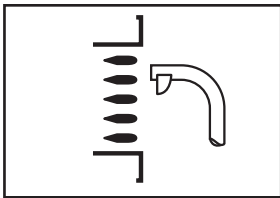
Throw values (T) in Table 1 are based on a Terminal Velocity (V_T) of 75 fpm. Throw values at other terminal velocities (V_T 50 to V_T 150 fpm) are established by multiplying throw (T) in table 1 by Throw Factor in table below.

Multiply Throw (T) in Table 1 by Factor				
VT (fpm)	50	75	100	150
Throw factor	x 1.5	x 1.0	x .76	x .5

Example;

A_k area for listed size 24" x 10" for GDA20 with deflection setting at 42° = 1.1 sq. feet.

AIR MEASUREMENT



2220A Velometer Jet for V_k velocity measurement
 $CFM = A_k \times V_k$

A_k OUTLET AREA IN SQ. FEET

	LISTED HEIGHT										DEFLECTION															
	4		5		6		8		10		12		14		16		18		20		24		0°	22°	42°	55°
	LISTED WIDTH																									
LISTED WIDTH	6		5																				.09	.08	.07	.06
	8		6																				.11	.10	.09	.08
	10		8		6																		.17	.15	.13	.12
	12		10		8																		.22	.20	.18	.17
	14		12		10		8																.28	.25	.23	.21
	18		14		12																		.33	.30	.27	.25
	20		16		14		10																.39	.35	.32	.29
	24		20		16		12		10														.50	.45	.41	.38
	30		24		20		14		12														.67	.60	.55	.50
			30		24		18		14		12												.78	.70	.64	.58
					26		20		16		14												.89	.80	.73	.67
					30		24		18		16		14										1.0	.90	.82	.75
						26		22		18		16										1.1	1.0	.91	.83	
						30		24		20		18		16								1.3	1.2	1.1	1.0	
								30		24		22		18								1.6	1.4	1.3	1.2	
										28		24		20		18						1.8	1.6	1.5	1.3	
												30		26		24		20				2.0	1.8	1.6	1.5	
														30		26		24				2.2	2.0	1.8	1.7	
																30		28		24		2.8	2.5	2.3	2.1	
																		28				3.3	3.0	2.7	2.5	
																		30				3.9	3.5	3.2	2.9	

Spiral Duct Grilles Single and Double Deflection Adjustable - GDA Series

TOTAL AIR DROP FROM SIDEWALL OUTLET

The drop of an air stream varies directly with cooling temperature differential, throw and inversely with outlet velocity (V_k). The total drop of a cooled air stream is tabulated for two typical conditions of cooling temperature differentials and a range of throws and outlet velocities.

V_k in fpm	Sidewall Throw In Feet													
	10		15		20		25		30		40		50	
	- 18F	- 25F	- 18F	- 25F	- 18F	- 25F	- 18F	- 25F	- 18F	- 25F	- 18F	- 25F	- 18F	- 25F
500	3.5	4.0	5.5	6.0	7.5	8.5	9.0	10.0	10.5	13.5	15.5	18.0	18.5	23.0
750	2.5	3.5	4.0	5.5	6.0	6.5	7.0	8.0	8.5	10.5	11.5	14.5	15.0	18.5
1000	2.0	3.0	3.5	4.0	5.0	5.5	6.0	6.5	7.0	8.5	10.0	12.0	12.5	16.0
1250	2.0	2.5	3.0	3.5	4.5	5.0	5.5	6.0	6.5	7.5	9.0	11.0	11.5	13.5
1500	1.5	2.0	3.0	3.0	4.0	4.5	5.0	5.5	6.0	7.0	8.5	9.5	10.5	12.5
1750	1.0	2.0	2.5	2.5	3.5	4.0	4.5	5.0	5.5	6.5	8.0	9.0	10.0	11.5
2000	1.0	1.5	2.5	2.5	3.5	4.0	4.0	4.5	5.0	6.0	7.5	8.5	9.5	10.5

TOTAL AIR DROP

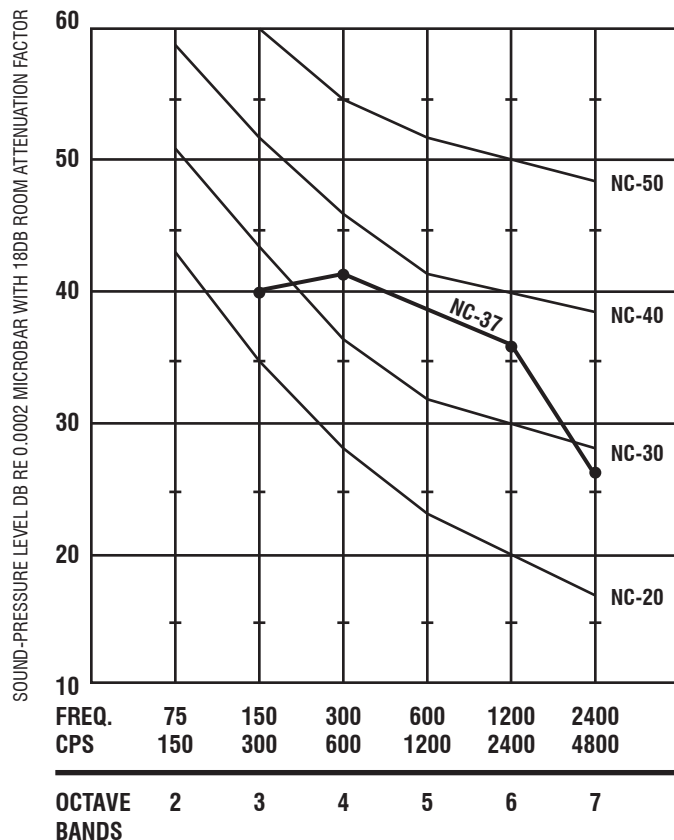
DROP DUE TO SPREAD + DROP DUE TO COOLING TEMPERATURE DIFFERENTIAL

RECOMMENDED NC CRITERIA

NC Curve	Communication Environment	Typical Occupancy
Below NC 25	Extremely quiet environment, suppressed speech is quite audible, suitable for acute pickup of all sounds.	Broadcasting studios, concert halls, music rooms.
NC 30	Very quiet office, suitable for large conferences; telephone use satisfactory.	Resistances, theatres, libraries, executive offices, directors' rooms.
NC 35	Quiet office; satisfactory for conference at a 15 ft. table; normal voice 10-30 ft.; telephone use satisfactory.	Private offices, schools, hotel rooms, courtrooms, churches, hospital rooms.
NC 40	Satisfactory for conferences at a 6-8 ft. table; normal voice 6-12 ft.; telephone use satisfactory.	General offices, labs, dining rooms.
NC 45	Satisfactory for conferences at a 4-5 ft. table; normal voice 3-6 ft.; raised voice 6-12 ft.; telephone use occasionally difficult.	Retail store cafeterias, lobby areas, large drafting & engineering offices, reception areas.
Above NC 50	Unsatisfactory for conferences of more than two or three persons; normal voice 1-2 ft.; raised voice 3-6 ft.; telephone use slightly difficult.	IBM rooms, stenographic pools, print machine rooms, process areas.

TYPICAL NC SPECTRUM T64

24" x 6" 22° DEFLECTION
(975 CFM) V_k (1400 FPM)



GRILLES



STEEL

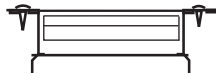
MODELS

GDS1 supply, single deflection spiral duct grille
 GDS2 supply, double deflection spiral duct grille



Fastening Methods

Air Scoop: For grilles with air scoop, add suffix 8



Screw holes

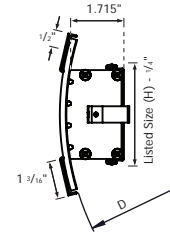
Single deflection supply spiral duct grilles are recommended for applications requiring pattern adjustability in a horizontal plane.

Double-deflection supply spiral duct grilles are recommended for application in systems requiring optimum flexibility of pattern changes to accommodate changing job conditions.

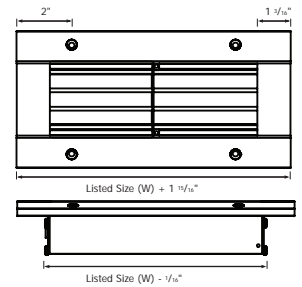
The combination of streamlined foil shaped bars and 17 mm (2/3 inch) bar spacing maintains a high effective area capacity of greater than 80% which minimizes outlet velocity, reduces pressure drop and assures quiet operation. Individually adjustable bars are capable of shortening throw up to one-half with a wide spread deflection requiring only a 20% increase in outlet velocity at a fixed volume.

GDS Series have extruded aluminum frames and bars which follow the curve on the face of the grille.

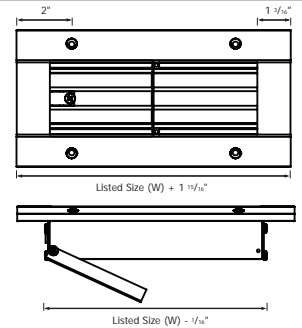
Dimensions



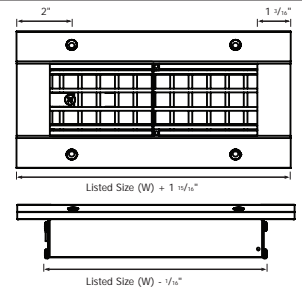
GDS10



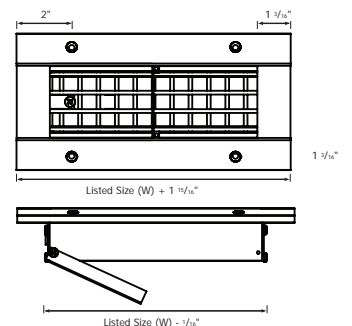
GDS18



GDS20



GDS28



HOW TO ORDER GDA SERIES

GDS28-D14 1006 /W

<p>MODEL SERIES Alum Spiral Duct Grille GDS</p> <p>AIR PATTERN Single Deflection 1 Double Deflection 2</p> <p>GRILLE/AIR SCOOP Grille Only 0 Grille with Air Scoop 8</p>	<p style="text-align: right;">White (Default) /W</p> <p style="text-align: center;">HEIGHT (INCHES)</p> <p style="text-align: center;">WIDTH (INCHES)</p> <p style="text-align: center;">DUCT DIMENSION Duct Diameter -D##</p>
--	---

MAX. LISTED SIZE: 36"x12"
FINISH: Powder baked enamel paint for durability. Default is White.
 Other finishes available (see chart for more).

DATA SHEET

ENGINEERING PERFORMANCE DATA

Rev. 0

SPIRAL DUCT GRILLES Single and Double Deflection Adjustable - GDS Series



TABLE 1

LISTED HEIGHT										Outlet Velocity 450-600 FPM					Outlet Velocity 550-700 FPM					Outlet Velocity 600-800 FPM					Outlet Velocity 700-1000 FPM				
										CFM		Deflection			CFM		Deflection			CFM		Deflection			CFM		Deflection		
0°	22°	42°	55°	0°	22°	42°	55°	0°	22°			42°	55°	0°			22°	42°	55°										
V _K		V _K		V _K		V _K		V _K		V _K		V _K		V _K		V _K		V _K											
P _T		P _T		P _T		P _T		P _T		P _T		P _T		P _T		P _T		P _T											
Throw (T) V _T 75		Throw (T) V _T 75		Throw (T) V _T 75		Throw (T) V _T 75		Throw (T) V _T 75		Throw (T) V _T 75		Throw (T) V _T 75		Throw (T) V _T 75		Throw (T) V _T 75		Throw (T) V _T 75											
4	5	6	8	10	12	14	16	18	20	24																			
6 5 8 6 10 8 6										40	6	5	4	3	45	8	7	6	4	60	10	9	7	5	65	11	10	8	6
										50	7	6	5	4	60	9	11	6	5	70	11	10	8	6	80	12	11	9	7
										75	9	7	6	5	90	10	9	7	6	100	12	11	9	7	125	13	12	10	8
12 10 8 14 12 10 8 18 14 12										100	10	8	6	5	125	11	9	8	7	150	13	12	9	8	175	14	13	11	8
										125	11	9	7	6	150	12	11	9	7	175	14	13	10	8	200	16	14	11	9
										150	11	10	8	7	175	13	11	10	8	200	15	14	11	9	250	17	15	12	10
20 16 14 10 24 20 16 12 10 30 24 20 14 12										175	12	11	9	7	200	15	13	11	9	250	17	15	12	9	275	19	17	14	11
										225	13	12	10	8	275	16	14	12	10	300	19	16	13	10	350	21	18	15	12
										300	14	13	11	9	350	18	15	13	10	425	20	17	15	11	475	24	20	17	13
38 30 24 18 14 12 40 32 26 20 16 14 44 36 30 24 18 16 14										350	17	14	12	9	425	20	17	13	11	500	22	20	17	12	550	26	22	18	14
										400	18	16	13	10	475	21	18	15	12	550	24	21	18	13	650	28	24	20	15
										450	19	17	13	11	550	22	19	17	13	625	26	22	19	14	725	30	25	22	17
44 36 26 22 18 16 48 40 30 24 20 18 16 48 38 30 24 22 18										500	20	17	14	12	600	24	20	18	13	700	27	24	20	15	800	32	27	23	18
										600	21	18	15	12	700	25	22	18	14	850	29	25	22	16	950	34	29	25	19
										700	23	20	17	13	850	28	24	20	15	975	33	28	24	18	1125	37	31	27	21
40 32 28 24 20 18 42 36 30 26 24 22 20 46 42 36 30 26 24 22										800	25	21	18	14	950	31	26	22	17	1125	35	30	26	20	1275	39	34	29	22
										900	27	22	19	15	1100	32	27	23	18	1250	36	31	27	21	1450	42	36	31	23
										1000	29	25	21	16	1200	34	29	25	19	1400	40	34	29	22	1600	45	39	34	25
44 38 34 30 28 24 48 42 36 34 28 44 40 36 30										1250	32	27	23	18	1500	36	30	27	23	1750	43	37	31	24	2000	48	43	36	27
										1500	34	29	25	19	1800	39	32	29	25	2100	45	40	34	26	2400	52	46	39	30
										1750	37	32	27	21	2100	42	35	32	27	2450	48	44	37	28	2800	55	49	42	32
48 42 36 28 24 48 40 2250 41 36 30 24 42 2500 43 38 32 25 48 3000 46 40 34 27										2000	39	34	29	22	2400	45	38	34	29	2800	52	46	40	30	3200	58	52	44	34
										2250	41	36	30	24	2700	48	40	36	31	3150	54	48	42	32	3600	61	54	46	37
										2500	43	38	32	25	3000	51	42	38	33	3500	57	51	44	33	4000	64	57	49	39
										3000	46	40	34	27	3600	54	45	40	35	4200	60	53	47	35	4800	68	60	52	42

NC 30

NC 35



NC40

SYMBOLS

V_T Terminal Velocity in fpm
V_R Room Velocity in fpm
V_K Outlet Velocity in fpm

A_K Outlet area in Sq. Feet
P_T Total Pressure H₂O
P_S Static Pressure H₂O

NC Re 8db Room attenuation
T Throw in feet at X and Y

ENGINEERING PERFORMANCE DATA

SPIRAL DUCT GRILLES

Single and Double Deflection Adjustable - GDS Series



AIR PATTERN SETTINGS

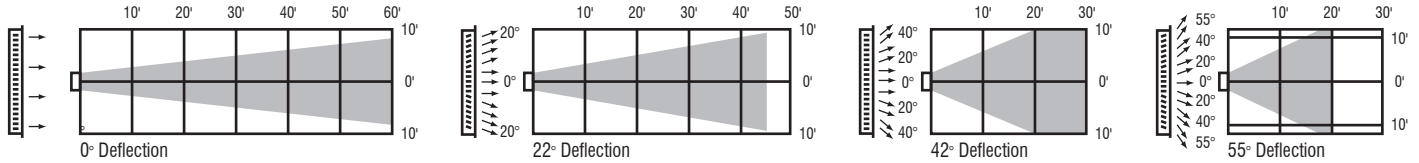


TABLE 1 (Cont'd)

LISTED HEIGHT				Outlet Velocity 900-1200 FPM					Outlet Velocity 1100-1450 FPM				Outlet Velocity 1250-1700 FPM				Outlet Velocity 1450-1900 FPM																																	
				CFM	Deflection				CFM	Deflection				CFM	Deflection				CFM	Deflection																														
					0°	20°	40°	55°		0°	20°	40°	55°		0°	20°	40°	55°		0°	20°	40°	55°																											
					V _k					V _k					V _k					V _k																														
900	1000	1100	1200	1100	1200	1300	1450	1250	1400	1550	1700	1450	1600	1750	1900																																			
P _r				P _r				P _r				P _r																																						
.05 .06 .08 .09				.08 .09 .10 .13				.09 .12 .15 .18				.13 .16 .19 .3																																						
Throw (T) V _r 75				Throw (T) V _r 75				Throw (T) V _r 75				Throw (T) V _r 75																																						
4	5	6	8	10	12	14	16	18	20	24																																								
6	5										80	13	11	9	7	100	15	13	11	8	125	18	15	13	10	150	19	16	13	10	175	21	18	14	11	225	24	20	17	13	225	27	23	19	15					
8	6										100	15	13	11	8	125	18	15	13	10	150	19	16	13	10	175	21	18	14	11	225	24	20	17	13	225	27	23	19	15										
10	8	6									150	17	14	12	9	175	20	17	14	11	200	24	20	17	13	225	27	23	19	15	275	31	27	22	17	325	36	32	26	20										
12	10	8									200	18	15	13	10	250	22	19	15	12	275	25	21	18	14	325	29	25	21	17	350	28	25	20	15	400	33	28	24	18	475	36	32	26	20					
14	12	10	8								250	21	18	15	11	300	15	21	18	14	350	28	25	20	15	400	33	28	24	18	425	31	27	22	17	475	36	32	26	20										
18	14	12									300	24	20	16	13	350	27	24	20	15	425	31	27	22	17	475	36	32	26	20	500	34	30	25	19	550	39	32	27	21	625	41	35	30	23	625	41	35	30	23
20	16	14	10								350	25	21	18	14	425	30	25	21	17	500	34	30	25	19	550	39	32	27	21	550	34	30	25	19	550	39	32	27	21	625	41	35	30	23	625	41	35	30	23
24	20	16	12	10							450	27	23	19	15	550	32	28	24	18	625	37	32	27	22	725	42	36	31	24	725	42	36	31	24	725	42	36	31	24	850	41	35	30	23	850	41	35	30	23
30	24	20	14	12							600	29	25	21	16	725	35	30	26	20	850	41	35	30	23	950	45	40	34	26	950	45	40	34	26	950	45	40	34	26	1125	49	43	38	28	1125	49	43	38	28
38	30	24	18	14	12						700	32	28	24	18	850	39	33	28	21	975	45	39	33	25	1125	49	43	38	28	975	45	39	33	25	1125	49	43	38	28	1125	49	43	38	28	1125	49	43	38	28
40	32	26	20	16	14						800	34	30	25	19	950	41	35	30	22	1125	48	41	35	27	1275	52	46	40	31	1275	52	46	40	31	1275	52	46	40	31	1275	52	46	40	31	1275	52	46	40	31
44	36	30	24	18	16	14					900	36	31	26	20	1075	43	37	32	24	1250	51	43	37	28	1450	55	49	42	32	1450	55	49	42	32	1450	55	49	42	32	1450	55	49	42	32	1450	55	49	42	32
44	36	26	22	18	16						1000	39	33	28	22	1200	45	40	34	26	1400	53	45	39	30	1600	58	51	44	34	1600	58	51	44	34	1600	58	51	44	34	1600	58	51	44	34	1600	58	51	44	34
48	40	30	24	20	18	16					1200	42	36	31	24	1450	48	42	36	28	1675	57	48	42	32	1925	61	54	46	36	1925	61	54	46	36	1925	61	54	46	36	1925	61	54	46	36	1925	61	54	46	36
48	40	38	30	24	22	18					1400	45	39	34	26	1675	52	45	40	31	1950	60	51	45	35	2250	58	51	44	34	2250	60	51	44	34	2250	60	51	44	34	2250	60	51	44	34	2250	60	51	44	34
		40	32	28	24	20	18				1600	47	43	37	28	1925	56	48	43	34	2250		54	47	39	2500		62	53	43	2500		62	53	43	2500		62	53	43	2500		62	53	43	2500		62	53	43
		42	36	30	26	24	22	20			1800	49	44	40	31	2150	59	51	46	35	2500		57	50	41	2750			56	46	2750			56	46	2750			56	46	2750			56	46	2750			56	46
		46	42	36	30	26	24	22			2000	52	47	42	32	2400		54	49	38	2800		61	53	43	3200			59	48	3200			59	48	3200			59	48	3200			59	48	3200			59	48
				44	38	34	30	28	24		2500	56	50	45	34	3000		59	53	41	3500			58	47	4000			54	47	4000			54	47	4000			54	47	4000			54	47	4000			54	47
				48	42	36	34	28			3000	60	54	48	36	3600			58	44	4200			52	4800					52	4800					52	4800					52	4800							
					44	40	36	30			3500		59	53	40	4200			49	4900			56						56					56					56					56						
						48	42	36	28	24	4000			57	43	4800			54	5600			60						60					60					60					60						
						48	48	40			4500			60	45	5400			58																															
						42					5000			49																																				
						48					6000			54																																				

ENGINEERING PERFORMANCE DATA

SPIRAL DUCT GRILLES

Single and Double Deflection Adjustable - GDA Series



A_k OUTLET AREA IN SQ. FEET

THROW FACTORS

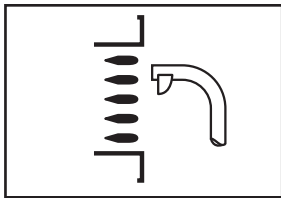
Throw values (T) in Table 1 are based on a Terminal Velocity (V_T) of 75 fpm. Throw values at other terminal velocities (V_T 50 to V_T 150 fpm) are established by multiplying throw (T) in table 1 by Throw Factor in table below.

Multiply Throw (T) in Table 1 by Factor				
VT (fpm)	50	75	100	150
Throw factor	x 1.5	x 1.0	x .76	x .5

Example;

A_k area for listed size 24" x 10" for GDA20 with deflection setting at 42° = 1.1 sq. feet.

AIR MEASUREMENT



2220A Velometer Jet for V_k velocity measurement CFM = A_k x V_k

LISTED WIDTH	LISTED HEIGHT										DEFLECTION																										
	4			5			6			8			10			12			14			16			18			20			24			0°	22°	42°	55°
	4	5	6	8	10	12	14	16	18	20	24	0°	22°	42°	55°																						
LISTED WIDTH	6	5									.09	.08	.07	.06																							
	8	6									.11	.10	.09	.08																							
	10	8	6								.17	.15	.13	.12																							
	12	10	8								.22	.20	.18	.17																							
	14	12	10	8							.28	.25	.23	.21																							
	18	14	12								.33	.30	.27	.25																							
	20	16	14	10							.39	.35	.32	.29																							
	24	20	16	12	10						.50	.45	.41	.38																							
	30	24	20	14	12						.67	.60	.55	.50																							
	38	30	24	18	14	12					.78	.70	.64	.58																							
	40	32	26	20	16	14					.89	.80	.73	.67																							
	44	36	30	24	18	16	14				1.0	.90	.82	.75																							
44	36	26	22	18	16					1.1	1.0	.91	.83																								
48	40	30	24	20	18	16				1.3	1.2	1.1	1.0																								
48	38	30	24	22	18					1.6	1.4	1.3	1.2																								
40	32	28	24	20	18					1.8	1.6	1.5	1.3																								
42	36	30	26	24	22	20				2.0	1.8	1.6	1.5																								
46	42	36	30	26	24	22				2.2	2.0	1.8	1.7																								
44	38	34	30	28	24					2.8	2.5	2.3	2.1																								
48	42	36	34	28						3.3	3.0	2.7	2.5																								
44	40	36	30	3.9	3.5	3.2	2.9																														
48	42	36	4.5	4.0	3.6	3.3																															
48	40	5.0	4.5	4.1	3.8																																
42	5.6	5.0	4.5	4.2																																	
48	6.7	6.0	5.4	5.0																																	

ENGINEERING PERFORMANCE DATA

SPIRAL DUCT GRILLES

Single and Double Deflection Adjustable - GDS Series



TOTAL AIR DROP FROM SIDEWALL OUTLET

The drop of an air stream varies directly with cooling temperature differential, throw and inversely with outlet velocity (V_k). The total drop of a cooled air stream is tabulated for two typical conditions of cooling temperature differentials and a range of throws and outlet velocities.

V_k in fpm	Sidewall Throw In Feet													
	10		15		20		25		30		40		50	
	- 18F	- 25F	- 18F	- 25F	- 18F	- 25F	- 18F	- 25F	- 18F	- 25F	- 18F	- 25F	- 18F	- 25F
500	3.5	4.0	5.5	6.0	7.5	8.5	9.0	10.0	10.5	13.5	15.5	18.0	18.5	23.0
750	2.5	3.5	4.0	5.5	6.0	6.5	7.0	8.0	8.5	10.5	11.5	14.5	15.0	18.5
1000	2.0	3.0	3.5	4.0	5.0	5.5	6.0	6.5	7.0	8.5	10.0	12.0	12.5	16.0
1250	2.0	2.5	3.0	3.5	4.5	5.0	5.5	6.0	6.5	7.5	9.0	11.0	11.5	13.5
1500	1.5	2.0	3.0	3.0	4.0	4.5	5.0	5.5	6.0	7.0	8.5	9.5	10.5	12.5
1750	1.0	2.0	2.5	2.5	3.5	4.0	4.5	5.0	5.5	6.5	8.0	9.0	10.0	11.5
2000	1.0	1.5	2.5	2.5	3.5	4.0	4.0	4.5	5.0	6.0	7.5	8.5	9.5	10.5

TOTAL AIR DROP

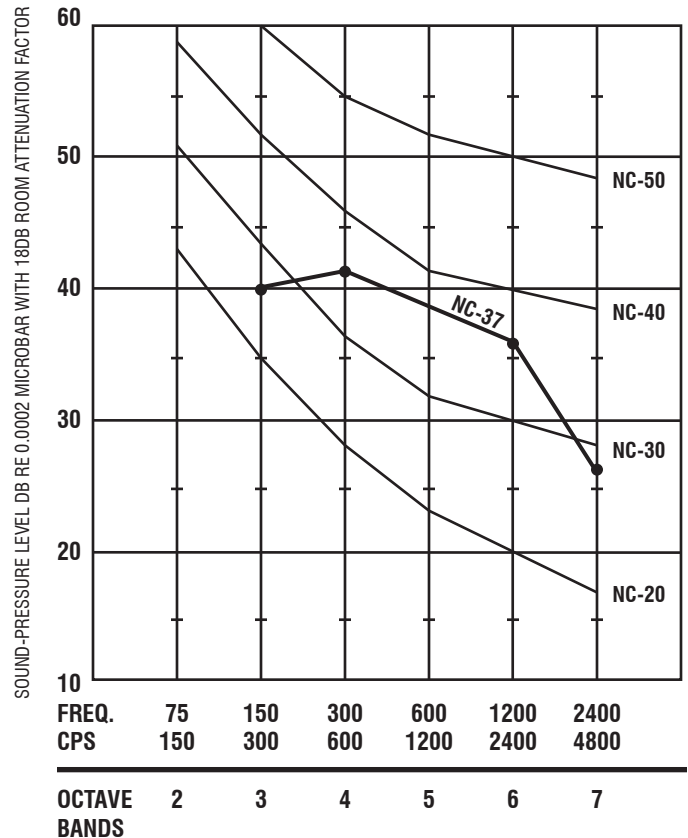
DROP DUE TO SPREAD + DROP DUE TO COOLING TEMPERATURE DIFFERENTIAL

RECOMMENDED NC CRITERIA

NC Curve	Communication Environment	Typical Occupancy
Below NC 25	Extremely quiet environment, suppressed speech is quite audible, suitable for acute pickup of all sounds.	Broadcasting studios, concert halls, music rooms.
NC 30	Very quiet office, suitable for large conferences; telephone use satisfactory.	Resistances, theatres, libraries, executive offices, directors' rooms.
NC 35	Quiet office; satisfactory for conference at a 15 ft. table; normal voice 10-30 ft.; telephone use satisfactory.	Private offices, schools, hotel rooms, courtrooms, churches, hospital rooms.
NC 40	Satisfactory for conferences at a 6-8 ft. table; normal voice 6-12 ft.; telephone use satisfactory.	General offices, labs, dining rooms.
NC 45	Satisfactory for conferences at a 4-5 ft. table; normal voice 3-6 ft.; raised voice 6-12 ft.; telephone use occasionally difficult.	Retail store cafeterias, lobby areas, large drafting & engineering offices, reception areas.
Above NC 50	Unsatisfactory for conferences of more than two or three persons; normal voice 1-2 ft.; raised voice 3-6 ft.; telephone use slightly difficult.	IBM rooms, stenographic pools, print machine rooms, process areas.

TYPICAL NC SPECTRUM T64

24" x 6" 22° DEFLECTION
(975 CFM) V_k (1400 FPM)



ENGINEERING PERFORMANCE DATA

T-Bar lay-in return air grilles - Series GRT Fixed Bar Type 45° Deflected Bars



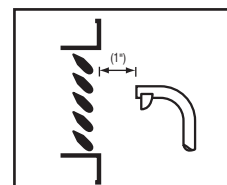
Listed Size W x H	A _K	NC 20-25 Application Non-Ducted		NC 25-30 Application Ducted		NC 30-40 Application Ducted	
		P _s		P _s		P _s	
		- .02"	- .03"	- .08"	- .10"	- .15"	- .20"
		CFM	CFM	CFM	CFM	CFM	CFM
10 x 6	.26	55	65	105	115	140	160
10 x 8	.34	75	90	145	160	195	225
12 x 8	.42	90	110	180	200	245	280
14 x 8	.50	110	135	220	245	300	345
12 x 10	.53	125	150	245	275	335	385
14 x 10	.63	155	190	310	345	420	485
12 x 12	.64	160	195	315	350	425	490
20 x 10	.75	170	205	335	375	455	525
14 x 14	.89	240	290	470	525	640	735
20 x 14	1.3	370	450	735	825	1005	1155
24 x 12	1.4	380	465	755	845	1030	1185
26 x 14	1.7	505	615	1000	1120	1365	1570
20 x 20	1.9	575	700	1140	1275	1555	1790
36 x 12	2.1	600	732	1195	1340	1635	1880
32 x 14	2.2	630	770	1255	1405	1715	1970
26 x 20	2.5	770	940	1530	1715	2090	2405
24 x 24	2.8	880	1075	1750	1960	2390	2750
32 x 20	3.2	970	1185	1930	2160	2635	3030
26 x 26	3.3	1040	1270	2070	2320	2830	3255
38 x 20	3.8	1170	1425	2320	2600	3170	3645
32 x 26	4.1	1320	1610	2625	2940	3585	4120
36 x 24	4.3	1355	1655	2695	3020	3685	4235
38 x 26	4.9	1580	1925	3135	3510	4280	4920
48 x 24	5.9	1940	2365	3855	4315	5265	6055
38 x 30	6.1	2010	2450	3995	4475	5460	6280
50 x 26	6.6	2130	2600	4240	4750	5795	6665
50 x 32	8.1	2700	3295	5370	6015	7340	8440
50 x 38	9.7	3220	3930	6405	7175	8755	10065

Performance of any size not shown in the tables will be the same as for the size shown with the same listed size area.

EXAMPLE:

A 38 x 18 size (not shown) has a listed area of 576 sq. in. Its performance will be identical to a 26 x 26 size (shown) which has the same listed size area of 576 sq. in.

AIR MEASUREMENT



SYMBOLS P_s Static Pressure Inches H₂O
A_K Outlet Area, 1" Out from Face
NC Re 10 db Room attenuation

2220A Velometer Jet for V_K velocity measurement.
CFM = A_K x V_K

GRILLES & REGISTERS



	ALUMINUM	STEEL	
MODELS	GAA1	GSA1	supply, single deflection
	GAA2	GSA2	supply, double deflection
	GAA4	GSA4	return, single row, fixed 45 degree



GSA20-H

Rev. 9

FRONT ROW BLADES DIRECTION: Parallel to width, (default) or add suffix H Parallel to height, add suffix V

DAMPERS: Grilles (no damper) Register (with damper): For registers with steel opposed blade damper: add suffix 7

Single deflection supply grilles and registers are recommended for applications requiring pattern adjustability in a single horizontal or vertical plane, sill or sidewall location at ceiling line, or heating application only.

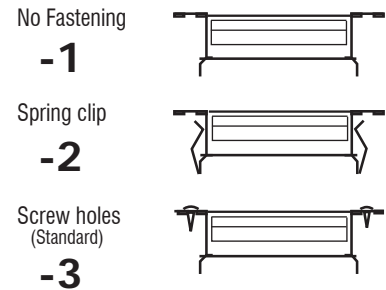
Double-deflection supply grilles and registers are recommended for application in systems requiring optimum flexibility of pattern change to accommodate changing job conditions.

The combination of streamlined foil shaped bars and 17 mm (2/3-inch) bar spacing maintains a high effective area capacity of greater than 80% which minimizes outlet velocity, reduces pressure drop and assures quiet operation. Individually adjustable bars are capable of shortening throw up to one-half with a wide spread deflection requiring only a 20% increase in outlet velocity at a fixed volume.

GAA Series (aluminum) have extruded aluminum frames with roll formed aluminum bars.

GSA Series (steel) have extruded aluminum frames with steel bars. This unique feature combines the beauty and rust resistance of the aluminium frame with the rigidity of steel bars.

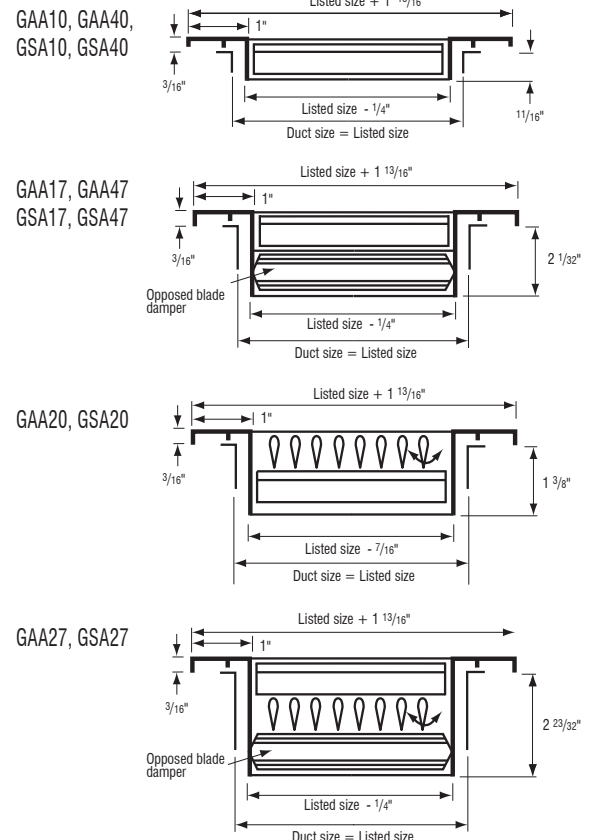
Fastening Methods



Accessories

-SF	-DS	-IS
Supplied w/ sub frame	Debris (Bird) Screen	Insect Screen

Dimensions



HOW TO ORDER GSA/GAA SERIES

GSA17-V -1-SF 1004 /W

MODEL SERIES	AIR PATTERN	GRILLE/REGISTER	BLADE ORIENTATION (Optional)	FASTENING METHOD (Optional)	FINISH (Optional)
GSA Steel	Single Adjust. 1	Grille 0	Horizontal (Standard) -H	No Fastening -1	White (Standard) /W
GAA Aluminium	Double Adjust. 2	Register 7	Vertical -V	Spring Clip -2	Custom (See chart) /C
	Single Fixed 4			Screw (Standard) -3	

WIDTH (INCHES): 1004

LENGTH (INCHES): 1004

OPTIONS: Sub Frame **-SF**, Debris Screen **-DS**, Insect Screen **-IS**

MAX. LISTED SIZE: 36"x36" (multiple sections furnished for larger sizes)
FINISH: Powder baked enamel paint for durability. White is standard. (Other finishes available).

DATA SHEET

SUPPLY AIR GRILLES AND REGISTERS

Single and Double Deflection adjustable Type - Series GSA & GAA



TABLE 1

LISTED HEIGHT										Outlet Velocity 450-600 FPM					Outlet Velocity 550-700 FPM					Outlet Velocity 600-800 FPM					Outlet Velocity 700-1000 FPM				
										CFM	Deflection				CFM	Deflection				CFM	Deflection				CFM	Deflection			
0°	22°	42°	55°	0°	22°	42°	55°	0°	22°		42°	55°	0°	22°		42°	55°												
V _K				V _K				V _K				V _K																	
450	500	550	600	550	600	650	700	600	700		750	800	700	800		900	1000												
P _T				P _T				P _T				P _T																	
.01	.01	.02	.02	.02	.02	.03	.03	.02	.03	.04	.04	.03	.04	.05	.06														
Throw (T) V _T 75										Throw (T) V _T 75																			
4	5	6	8	10	12	14	16	18	20	24																			
6 5 8 6 10 8 6										40 6 5 4 3					45 8 7 6 4					60 10 9 7 5					65 11 10 8 6				
										50 7 6 5 4					60 9 11 6 5					70 11 10 8 6					80 12 11 9 7				
										75 9 7 6 5					90 10 9 7 6					100 12 11 9 7					125 13 12 10 8				
12 10 8 14 12 10 8 18 14 12										100 10 8 6 5					125 11 9 8 7					150 13 12 9 8					175 14 13 11 8				
										125 11 9 7 6					150 12 11 9 7					175 14 13 10 8					200 16 14 11 9				
										150 11 10 8 7					175 13 11 10 8					200 15 14 11 9					250 17 15 12 10				
20 16 14 10 24 20 16 12 10 30 24 20 14 12										175 12 11 9 7					200 15 13 11 9					250 17 15 12 9					275 19 17 14 11				
										225 13 12 10 8					275 16 14 12 10					300 19 16 13 10					350 21 18 15 12				
										300 14 13 11 9					350 18 15 13 10					425 20 17 15 11					475 24 20 17 13				
38 30 24 18 14 12 40 32 26 20 16 14 44 36 30 24 18 16 14										350 17 14 12 9					425 20 17 13 11					500 22 20 17 12					550 26 22 18 14				
										400 18 16 13 10					475 21 18 15 12					550 24 21 18 13					650 28 24 20 15				
										450 19 17 13 11					550 22 19 17 13					625 26 22 19 14					725 30 25 22 17				
44 36 26 22 18 16 48 40 30 24 20 18 16 48 38 30 24 22 18										500 20 17 14 12					600 24 20 18 13					700 27 24 20 15					800 32 27 23 18				
										600 21 18 15 12					700 25 22 18 14					850 29 25 22 16					950 34 29 25 19				
										700 23 20 17 13					850 28 24 20 15					975 33 28 24 18					1125 37 31 27 21				
40 32 28 24 20 18 42 36 30 26 24 22 20 46 42 36 30 26 24 22										800 25 21 18 14					950 31 26 22 17					1125 35 30 26 20					1275 39 34 29 22				
										900 27 22 19 15					1100 32 27 23 18					1250 36 31 27 21					1450 42 36 31 23				
										1000 29 25 21 16					1200 34 29 25 19					1400 40 34 29 22					1600 45 39 34 25				
44 38 34 30 28 24 48 42 36 34 28 24 44 40 36 30										1250 32 27 23 18					1500 36 30 27 23					1750 43 37 31 24					2000 48 43 36 27				
										1500 34 29 25 19					1800 39 32 29 25					2100 45 40 34 26					2400 52 46 39 30				
										1750 37 32 27 21					2100 42 35 32 27					2450 48 44 37 28					2800 55 49 42 32				
48 42 36 28 24 48 40 2250 41 36 30 24 42 2500 43 38 32 25 48 3000 46 40 34 27										2000 39 34 29 22					2400 45 38 34 29					2800 52 46 40 30					3200 58 52 44 34				
										2250 41 36 30 24					2700 48 40 36 31					3150 54 48 42 32					3600 61 54 46 37				
										2500 43 38 32 25					3000 51 42 38 33					3500 57 51 44 33					4000 64 57 49 39				
										3000 46 40 34 27					3600 54 45 40 35					4200 60 53 47 35					4800 68 60 52 42				

NC 30

NC 35



NC40

SYMBOLS

- V_T Terminal Velocity in fpm
- V_R Room Velocity in fpm
- V_K Outlet Velocity in fpm
- A_K Outlet area in Sq. Feet
- P_T Total Pressure H₂O
- P_S Static Pressure H₂O
- NC Re 8db Room attenuation
- T Throw in feet at X and Y

ENGINEERING PERFORMANCE DATA

SUPPLY AIR GRILLES AND REGISTERS

Single and Double Deflection adjustable Type - Series GSA & GAA



AIR PATTERN SETTINGS

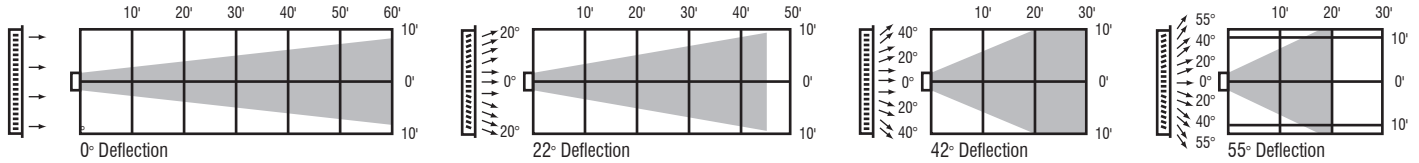


TABLE 1 (Cont'd)

LISTED HEIGHT				Outlet Velocity 900-1200 FPM					Outlet Velocity 1100-1450 FPM				Outlet Velocity 1250-1700 FPM				Outlet Velocity 1450-1900 FPM																											
				CFM	Deflection				CFM	Deflection				CFM	Deflection				CFM	Deflection																								
					0°	20°	40°	55°		0°	20°	40°	55°		0°	20°	40°	55°		0°	20°	40°	55°																					
					V _k					V _k					V _k					V _k																								
					900	1000	1100	1200		1100	1200	1300	1450		1250	1400	1550	1700		1450	1600	1750	1900																					
					P _r					P _r					P _r					P _r																								
Throw (T) V _r 75				Throw (T) V _r 75				Throw (T) V _r 75				Throw (T) V _r 75																																
4	5	6	8	10	12	14	16	18	20	24																																		
6	5										80	13	11	9	7	100	15	13	11	8	125	18	15	13	10	150	21	18	14	11	175	25	21	17	13	225	27	23	19	15				
8	6										100	15	13	11	8	125	18	15	13	10	150	21	18	14	11	175	25	21	17	13	225	27	23	19	15									
10	8	6									150	17	14	12	9	175	20	17	14	11	200	24	20	17	13	225	27	23	19	15														
12	10	8									200	18	15	13	10	250	22	19	15	12	275	25	21	18	14	325	29	25	21	17														
14	12	10	8								250	21	18	15	11	300	15	21	18	14	350	28	25	20	15	400	33	28	24	18														
18	14	12									300	24	20	16	13	350	27	24	20	15	425	31	27	22	17	475	36	32	26	20														
20	16	14	10								350	25	21	18	14	425	30	25	21	17	500	34	30	25	19	550	39	32	27	21														
24	20	16	12	10							450	27	23	19	15	550	32	28	24	18	625	37	32	27	22	725	42	36	31	24														
30	24	20	14	12							600	29	25	21	16	725	35	30	26	20	850	41	35	30	23	950	45	40	34	26														
38	30	24	18	14	12						700	32	28	24	18	850	39	33	28	21	975	45	39	33	25	1125	49	43	38	28														
40	32	26	20	16	14						800	34	30	25	19	950	41	35	30	22	1125	48	41	35	27	1275	52	46	40	31														
44	36	30	24	18	16	14					900	36	31	26	20	1075	43	37	32	24	1250	51	43	37	28	1450	55	49	42	32														
44	36	26	22	18	16						1000	39	33	28	22	1200	45	40	34	26	1400	53	45	39	30	1600	58	51	44	34														
48	40	30	24	20	18	16					1200	42	36	31	24	1450	48	42	36	28	1675	57	48	42	32	1925	61	54	46	36														
48	38	30	24	22	18						1400	45	39	34	26	1675	52	45	40	31	1950	60	51	45	35	2250	58	49	40	34														
		40	32	28	24	20	18				1600	47	43	37	28	1925	56	48	43	34	2250		54	47	39	2500		62	53	43														
		42	36	30	26	24	22	20			1800	49	44	40	31	2150	59	51	46	35	2500		57	50	41	2750			56	46														
		46	42	36	30	26	24	22			2000	52	47	42	32	2400		54	49	38	2800		61	53	43	3200			59	48														
				44	38	34	30	28	24		2500	56	50	45	34	3000		59	53	41	3500				58	47	4000																	
				48	42	36	34	28			3000	60	54	48	36	3600			58	44	4200				58	52	4800																	
					44	40	36	30			3500		59	53	40	4200			49		4900				56																			
						48	42	36			4000			57	43	4800				54	5600				60																			
						48	48	40			4500			60	45	5400				58																								
						42					5000				49																													
						48					6000				54																													

ENGINEERING PERFORMANCE DATA

SUPPLY AIR GRILLES AND REGISTERS

Single and Double Deflection adjustable Type - Series GSA & GAA



THROW FACTORS

Throw values (T) in Table 1 are based on a Terminal Velocity (V_T) of 75 fpm. Throw values at other terminal velocities (V_T 50 to V_T 150 fpm) are established by multiplying throw (T) in table 1 by Throw Factor in table below.

Multiply Throw (T) in Table 1 by Factor				
VT (fpm)	50	75	100	150
Throw factor	x 1.5	x 1.0	x .76	x .5

Grille sound ratings will be increased by integral or localized air volume dampering, by non-uniform air flow in the grille collar and by the addition of inherent system noise.

REGISTER THROTTLING CORRECTION

Damper throttling effect (excess pressure drop due to part closing of damper)	Press. Drop In. H ₂ O		
	.05"	.05"	.05"
Approximate damper opening	3/4	2/3	1/2
NC addition to single outlet sound rating	5	10	15

Damper throttling effect = excess pressure drop created by partially closing the register damper.

NC addition to be added to NC values of table 1.

Performance of any size not shown in the tables will be the same as for the size shown with the same listed size area.

EXAMPLE:

A 36 x 16 size (not shown) has a listed area of 576 sq. in. Its performance will be identical to a 24 x 24 size (shown) which has the same listed size area of 576 sq. in.

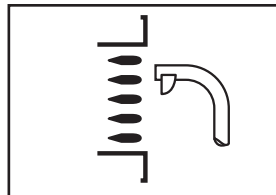
A_K OUTLET AREA IN SQ. FEET

LISTED WIDTH	LISTED HEIGHT								DEFLECTION																	
	4		5		6		8		10		12		14		16		18		20		24		0°	22°	42°	55°
	6	5																					.09	.08	.07	.06
8	6																						.11	.10	.09	.08
10	8	6																					.17	.15	.13	.12
12	10	8																					.22	.20	.18	.17
14	12	10	8																				.28	.25	.23	.21
18	14	12																					.33	.30	.27	.25
20	16	14	10																				.39	.35	.32	.29
24	20	16	12	10																			.50	.45	.41	.38
30	24	20	14	12																			.67	.60	.55	.50
38	30	24	18	14	12																		.78	.70	.64	.58
40	32	26	20	16	14																		.89	.80	.73	.67
44	36	30	24	18	16	14																	1.0	.90	.82	.75
44	36	26	22	18	16																		1.1	1.0	.91	.83
48	40	30	24	20	18	16																	1.3	1.2	1.1	1.0
48	38	30	24	22	18																		1.6	1.4	1.3	1.2
40	32	28	24	20	18																		1.8	1.6	1.5	1.3
		42	36	30	26	24	22	20															2.0	1.8	1.6	1.5
		46	42	36	30	26	24	22															2.2	2.0	1.8	1.7
				44	38	34	30	28	24														2.8	2.5	2.3	2.1
					48	42	36	34	28														3.3	3.0	2.7	2.5
						44	40	36	30														3.9	3.5	3.2	2.9
							48	42	36														4.5	4.0	3.6	3.3
								48	40														5.0	4.5	4.1	3.8
									42														5.6	5.0	4.5	4.2
									48														6.7	6.0	5.4	5.0

Example;

Listed size 24 x 10 GAA27 deflection setting 42° A_K area = 1.1 sq. feet.

AIR MEASUREMENT



2220A Velometer Jet for V_K velocity measurement CFM = $A_K \times V_K$

ENGINEERING PERFORMANCE DATA

SUPPLY AIR GRILLES AND REGISTERS

Single and Double Deflection adjustable Type - Series GSA & GAA



Total air drop from sidewall outlet

The drop of an air stream varies directly with cooling temperature differential, throw and inversely with outlet velocity (V_k). The total drop of a cooled air stream is tabulated for two typical conditions of cooling temperature differentials and a range of throws and outlet velocities.

V_k in fpm	Sidewall Throw In Feet													
	10		15		20		25		30		40		50	
	- 18F	- 25F	- 18F	- 25F	- 18F	- 25F	- 18F	- 25F	- 18F	- 25F	- 18F	- 25F	- 18F	- 25F
500	3.5	4.0	5.5	6.0	7.5	8.5	9.0	10.0	10.5	13.5	15.5	18.0	18.5	23.0
750	2.5	3.5	4.0	5.5	6.0	6.5	7.0	8.0	8.5	10.5	11.5	14.5	15.0	18.5
1000	2.0	3.0	3.5	4.0	5.0	5.5	6.0	6.5	7.0	8.5	10.0	12.0	12.5	16.0
1250	2.0	2.5	3.0	3.5	4.5	5.0	5.5	6.0	6.5	7.5	9.0	11.0	11.5	13.5
1500	1.5	2.0	3.0	3.0	4.0	4.5	5.0	5.5	6.0	7.0	8.5	9.5	10.5	12.5
1750	1.0	2.0	2.5	2.5	3.5	4.0	4.5	5.0	5.5	6.5	8.0	9.0	10.0	11.5
2000	1.0	1.5	2.5	2.5	3.5	4.0	4.0	4.5	5.0	6.0	7.5	8.5	9.5	10.5

TOTAL AIR DROP

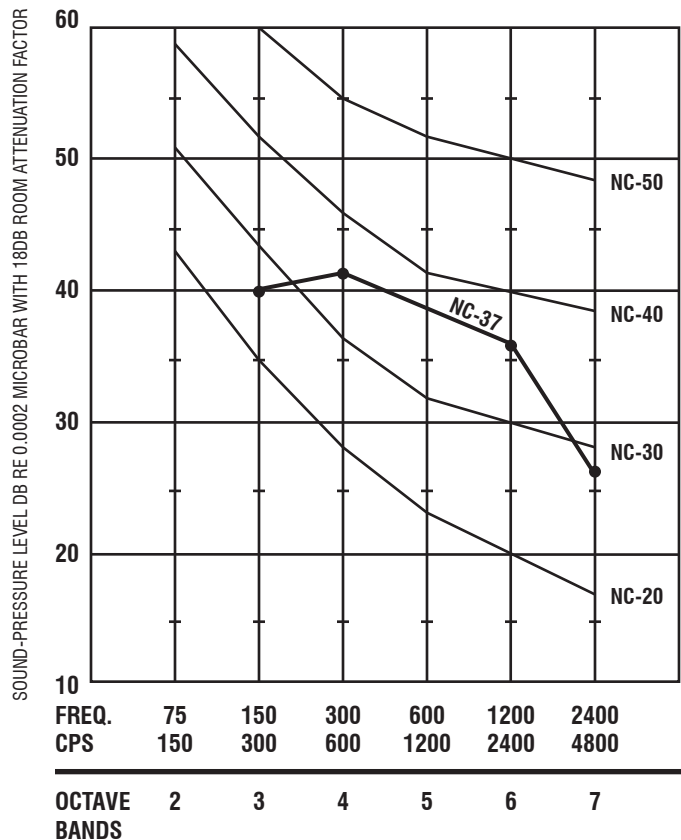
DROP DUE TO SPREAD + DROP DUE TO COOLING TEMPERATURE DIFFERENTIAL

RECOMMENDED NC CRITERIA

NC Curve	Communication Environment	Typical Occupancy
Below NC 25	Extremely quiet environment, suppressed speech is quite audible, suitable for acute pickup of all sounds.	Broadcasting studios, concert halls, music rooms.
NC 30	Very quiet office, suitable for large conferences; telephone use satisfactory.	Resistances, theatres, libraries, executive offices, directors' rooms.
NC 35	Quiet office; satisfactory for conference at a 15 ft. table; normal voice 10-30 ft.; telephone use satisfactory.	Private offices, schools, hotel rooms, courtrooms, churches, hospital rooms.
NC 40	Satisfactory for conferences at a 6-8 ft. table; normal voice 6-12 ft.; telephone use satisfactory.	General offices, labs, dining rooms.
NC 45	Satisfactory for conferences at a 4-5 ft. table; normal voice 3-6 ft.; raised voice 6-12 ft.; telephone use occasionally difficult.	Retail store cafeterias, lobby areas, large drafting & engineering offices, reception areas.
Above NC 50	Unsatisfactory for conferences of more than two or three persons; normal voice 1-2 ft.; raised voice 3-6 ft.; telephone use slightly difficult.	IBM rooms, stenographic pools, print machine rooms, process areas.

TYPICAL NC SPECTRUM T64

24" x 6" 22° DEFLECTION
(975 CFM) V_k (1400 FPM)



Return Air Grilles & Registers

Fixed Bar Type 45° Deflected Bars

Core Area (sq. ft.)	Nominal Size	CFM	NC 20				NC 30				NC 40	NC 50		
			200	300	400	500	600	700	800	900			1000	1100
			Velocity Pressure (in. w.g.)	0.002	0.006	0.01	0.016	0.022	0.031	0.040			0.050	0.062
Neg. Static Pressure (in. w.g.)	0.011	0.025	0.044	0.069	0.100	0.136	0.177	0.224	0.277	0.335				
0.15	7 x 4 6 x 5	CFM	30	45	60	75	90	105	120	135	150	165		
		NC	-	-	-	19	24	28	32	35	38	40		
0.18	8 x 4 6 x 6 7 x 5	CFM	36	54	72	90	108	126	144	162	180	198		
		NC	-	-	-	19	24	28	32	35	38	41		
0.22	10 x 4 7 x 6 8 x 5	CFM	44	66	88	110	132	154	176	198	220	242		
		NC	-	-	-	20	25	29	33	36	39	41		
0.26	12 x 4 8 x 6 10 x 5	CFM	52	78	104	130	156	182	208	234	260	286		
		NC	-	-	-	20	25	29	33	36	39	42		
0.30	14 x 4	CFM	60	90	120	150	180	210	240	270	300	330		
		NC	-	-	15	21	26	30	33	37	40	42		
0.34	16 x 4 10 x 6 12 x 5	CFM	68	102	136	170	204	238	272	306	340	374		
		NC	-	-	15	21	26	30	34	37	40	43		
0.39	18 x 4 12 x 6 14 x 5 8 x 8	CFM	78	117	156	195	234	273	312	351	390	429		
		NC	-	-	15	21	26	31	34	37	40	43		
0.46	20 x 4 14 x 6 16 x 5 10 x 8	CFM	92	138	184	230	276	322	368	414	460	506		
		NC	-	-	16	22	27	31	35	38	41	43		
0.52	24 x 4 16 x 6 18 x 5	CFM	104	156	208	260	312	364	416	468	520	572		
		NC	-	-	16	22	27	31	35	38	41	44		
0.60	28 x 4 18 x 6 10 x 10 20 x 5 12 x 8	CFM	120	180	240	300	360	420	480	540	600	660		
		NC	-	-	16	23	28	32	35	39	42	44		
0.69	30 x 4 20 x 6 12 x 10 24 x 5 14 x 8	CFM	138	207	276	345	414	483	552	621	690	759		
		NC	-	-	17	23	28	32	36	39	42	45		
0.81	36 x 4 22 x 6 14 x 10 28 x 5 16 x 8	CFM	162	243	324	405	486	567	648	729	810	891		
		NC	-	-	17	23	28	33	36	40	42	45		
0.90	40 x 4 26 x 6 16 x 10 32 x 5 18 x 8 12 x 12	CFM	182	273	364	455	546	637	728	819	910	1001		
		NC	-	-	18	24	29	33	37	40	43	45		
1.07	42 x 4 30 x 6 18 x 10 36 x 5 22 x 8 14 x 12	CFM	214	321	428	535	642	749	856	963	1070	1177		
		NC	-	-	18	24	29	33	37	40	43	46		
1.18	34 x 6 20 x 10 14 x 14 24 x 8 16 x 12	CFM	236	354	472	590	708	826	944	1062	1180	1298		
		NC	-	-	18	25	29	34	37	41	43	46		
1.34	38 x 6 22 x 10 16 x 14 28 x 8 18 x 12	CFM	268	402	536	670	804	938	1072	1206	1340	1474		
		NC	-	-	19	25	30	34	38	41	44	46		
1.60	44 x 6 26 x 10 18 x 14 32 x 8 22 x 12 16 x 16	CFM	320	480	640	800	960	1120	1280	1440	1600	1760		
		NC	-	-	19	25	30	35	38	41	44	47		
1.80	50 x 6 30 x 10 20 x 14 36 x 8 24 x 12 18 x 16	CFM	360	540	720	900	1080	1260	1440	1620	1800	1980		
		NC	-	-	20	26	31	35	39	42	45	47		
2.08	58 x 6 34 x 10 24 x 14 42 x 8 28 x 12 20 x 16	CFM	416	624	832	1040	1248	1456	1664	1872	2080	2288		
		NC	-	-	20	26	31	35	39	42	45	48		
2.45	50 x 8 32 x 12 24 x 16 38 x 10 28 x 14 20 x 18	CFM	490	735	980	1225	1470	1715	1960	2205	2450	2695		
		NC	-	-	20	27	32	36	39	43	46	48		
2.78	56 x 8 36 x 12 26 x 16 44 x 10 30 x 14 24 x 18	CFM	556	834	1112	1390	1668	1946	2224	2502	2780	3058		
		NC	-	-	21	27	32	36	40	43	46	48		
3.11	48 x 10 34 x 14 26 x 18 40 x 12 30 x 16 24 x 20	CFM	622	933	1244	1555	1866	2177	2488	2799	3110	3421		
		NC	-	-	21	27	32	36	40	43	46	49		
3.61	56 x 10 40 x 14 30 x 18 48 x 12 34 x 16 28 x 20	CFM	722	1083	1444	1805	2166	2527	2888	3249	3610	3971		
		NC	-	-	22	28	33	37	41	44	47	49		
4.29	56 x 12 40 x 16 32 x 20 48 x 14 36 x 18 30 x 22	CFM	858	1287	1716	2145	2574	3003	3432	3861	4290	4719		
		NC	-	-	22	28	33	37	41	44	47	50		
4.65	60 x 12 44 x 16 36 x 20 50 x 14 40 x 18 32 x 22	CFM	930	1395	1860	2325	2790	3255	3720	4185	4650	5115		
		NC	-	-	22	28	33	38	41	44	47	50		
5.58	60 x 14 48 x 18 38 x 22 54 x 16 42 x 20 36 x 24	CFM	1116	1674	2232	2790	3348	3906	4464	5022	5580	6138		
		NC	-	15	23	29	34	38	42	45	48	50		
6.25	72 x 14 52 x 18 40 x 24 60 x 16 48 x 20 32 x 30	CFM	1250	1875	2500	3125	3750	4375	5000	5625	6250	6875		
		NC	-	15	23	29	34	38	42	45	48	51		

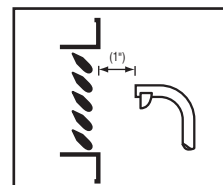
Performance Notes:

- Tested in accordance with ASHRAE Standard 70-2006 4. "Method of Testing for Rating the Performance of Air Outlets and Inlets."
- Air flow is in cfm.
- All pressures are in in. w.g.
- Performance data is for grille complete with opposed blade damper in the full open position. ⁻¹²
- NC values are based on room absorption of 10 dB re 10 Watts and one grille.
- Blanks "-" indicate an NC level below 15.
- Correction factors to be applied to table for no damper: pressure loss - multiply by 0.91, NC - subtract 5.

Symbol

NC Noise Criteria based on 10 db room absorption

Air measurement



220A Velometer Jet for V_K velocity measurement.
 $CFM = A_K \times V_K$

HOW TO SPECIFY GRILLES AND REGISTERS



Single Deflection Aluminum Supply Register

Supply and mounting of single deflection register with opposed blade damper, series **GAA17**. 2/3 inch blade spacing, constructed from powder coated aluminum, manufactured by Airvector.

Single Deflection Aluminum Return Grille

Supply and mounting of single deflection return grille, series **GAA10**. 2/3 inch blade spacing, constructed from powder coated aluminum, manufactured by Airvector.

Single Deflection Steel Supply Register

Supply and mounting of single deflection register with opposed blade damper, series **GSA17**. 2/3 inch blade spacing, constructed from powder coated aluminum frame and steel blades, manufactured by Airvector.

Single Deflection Steel Return Grille

Supply and mounting of single deflection return grille, series **GSA10**. 2/3 inch blade spacing, constructed from powder coated aluminum frame and steel blades, manufactured by Airvector.

Double Deflection Aluminum Supply Register

Supply and mounting of double deflection register with opposed blade damper, series **GAA27**. 2/3 inch blade spacing, constructed from powder coated aluminum, manufactured by Airvector.

Double Deflection Aluminum Return Grille

Supply and mounting of double deflection return grille, series **GAA20**. 2/3 inch blade spacing, constructed from powder coated aluminum, manufactured by Airvector.

Double Deflection Steel Supply Register

Supply and mounting of double deflection register with opposed blade damper, series **GSA27**. 2/3 inch blade spacing, constructed from powder coated aluminum frame and steel blades, manufactured by Airvector.

Double Deflection Steel Return Grille

Supply and mounting of double deflection return grille, series **GSA20**. 2/3 inch blade spacing, constructed from powder coated aluminum frame and steel blades, manufactured by Airvector.

Fixed 45° Aluminum Supply Register

Supply and mounting of 45 degree fixed blade register with opposed blade damper, series **GAA47**. 2/3 inch blade spacing, constructed from powder coated aluminum, manufactured by Airvector.

Fixed 45° Aluminum Return Grille

Supply and mounting of 45 degree fixed blade return grille, series **GAA40**. 2/3 inch blade spacing, constructed from powder coated aluminum, manufactured by Airvector.

Fixed 45° Steel Supply Register

Supply and mounting of 45 degree fixed blade register with opposed blade damper, series **GSA47**. 2/3 inch blade spacing, constructed from powder coated aluminum frame and steel blades, manufactured by Airvector.

Fixed 45° Steel Return Grille

Supply and mounting of 45 degree fixed blade return grille, series **GSA40**. 2/3 inch blade spacing, constructed from powder coated aluminum frame and steel blades, manufactured by Airvector.

ROUND DIFFUSERS



MODEL ICG ADJUSTABLE ROUND DIFFUSER

MODEL ICG - High Ceiling Round Diffuser Spun Aluminum

Airvector's ICG Aluminum Adjustable Round Diffusers are recommended for heating, ventilating, and cooling applications. ICG diffusers provide a 360° air diffusion pattern and excellent performance in VAV systems.

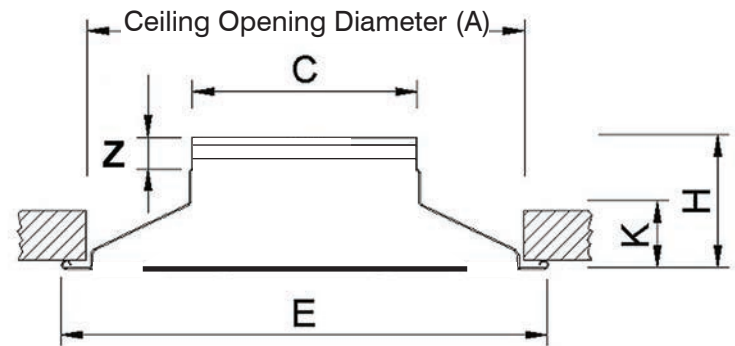
Full adjustability is possible by rotating the inner core clockwise or counterclockwise to move the cones up or down, changing from horizontal projection to vertical projection in accordance with the supply air temperature and reducing stratification. ICG diffusers provide great performance in temperatures differentials up to 54°F (12°C) and are suitable for premises with ceilings 8.5 ft (2.6 m) and higher. Original design by Lievore, Altherr & Molina for Madel.



ICG

Highlights

- Heavy-gauge aluminum construction
- Fully adjustable
- Powder paint coating - White (Custom Finishes Avail.)
- Available in Imperial and Metric dimensions



Imperial

Listed Size	Duct Size	A (in)	C (in)	E (in)	H (in)	K (in)	Z (in)
06	6"	19 59/64	5 3/4	13 5/16	4 15/16	1 47/64	1
08	8"	15 5/32	7 3/4	16 47/64	4 17/32	2 9/32	1
10	10"	18 17/64	9 3/4	19 3/8	4 31/64	2 1/4	1
12	12"	22 13/64	11 3/4	23 17/64	6 19/32	3 5/32	1
14	14"	24 13/16	13 29/32	26 1/16	5 33/64	3 17/64	1
16	16"	24 13/16	15 43/64	26 1/16	5 5/32	2 59/64	1
18	18"	31 7/32	17 19/32	32 3/4	6 13/16	4 11/64	1
20	20"	31 7/32	19 9/16	32 3/4	6 27/64	3 13/16	1

Metric

Listed Size	Duct Size	A (mm)	C (mm)	E (mm)	H (mm)	K (mm)	Z (mm)
160	160 mm	303	157	331	101	44	25
200	200mm	385	197	425	115	58	25
250	250mm	464	247	492	114	57	25
315	315mm	564	313	591	137	80	25
355	355mm	630	353	662	140	83	25
400	400mm	630	398	662	131	74	25
450	450mm	793	447	832	173	106	25
500	500mm	793	497	832	163	97	25

DATA SHEET

ENGINEERING PERFORMANCE DATA

MODEL ICG ADJUSTABLE ROUND DIFFUSER



Recommended Velocity and CFM

Neck Diameter	Free Area (sqf)	Vmin (fpm)	Vmax (fpm)	Min cfm	Max cfm
6" (160 mm)	0.215	590	1122	126	241
8" (200 mm)	0.338	590	1142	200	388
10" (250 mm)	0.527	590	886	312	468
12" (315 mm)	0.839	590	1122	491	950
14" (355 mm)	1.035	590	1220	609	1279
16" (400 mm)	1.345	590	1181	794	1606
18" (450 mm)	1.711	590	886	917	1561
20" (500 mm)	2.110	590	886	1112	1858

Isothermal Performance Data in Horizontal Flow Position

SIZE	Neck Velocity (fpm)	400	500	600	700	800	1000	1200	1400	1600
	Velocity Pressure (in H ₂ O)	.010	.016	.023	.031	.040	.063	.090	.122	.160
6" 160 mm	CFM	79	98	118	137	157	196	236	275	314
	Pressure Loss (in wg.)	.032	.044	.060	.080	.104	.153	.241	.301	.402
	NC	< 15	< 15	< 20	20	< 20	30	< 35	> 35	> 35
	Throw - Radius (ft)	4	5	6	9	11	13	17	20	25
8" 200 mm	CFM	140	175	209	244	279	349	419	489	559
	Pressure Loss (in wg.)	.028	.036	.056	.072	.096	.149	.209	.281	.361
	NC	< 15	< 15	< 20	30	< 35	< 35	35	> 35	> 35
	Throw - Radius (ft)	5	7	9	11	12	14	17	19	22
10" 250 mm	CFM	218	273	327	382	436	545	654	764	873
	Pressure Loss (in wg.)	.040	.060	.092	.120	.161	.249	.402	.602	-
	NC	< 15	< 15	< 20	< 25	< 30	35	> 35	> 35	-
	Throw - Radius (ft)	7	9	11	13	15	20	25	33	-
12" 315 mm	CFM	314	393	471	550	628	785	942	1100	1257
	Pressure Loss (in wg.)	.040	.056	.096	.129	.201	.309	.482	.703	-
	NC	< 15	< 20	< 30	30	< 40	> 40	> 40	> 40	-
	Throw - Radius (ft)	11	12	14	16	17	19	22	-	-
14" 355 mm	CFM	428	535	641	748	855	1069	1283	1497	1710
	Pressure Loss (in wg.)	.032	.052	.072	.108	.149	.221	.361	.482	.602
	NC	< 15	20	25	< 30	< 35	< 40	> 40	> 40	> 40
	Throw - Radius (ft)	10	12	15	17	18	21	26	27	-
16" 400 mm	CFM	559	698	838	977	1117	1396	1676	1955	2234
	Pressure Loss (in wg.)	.044	.072	.108	.129	.145	.241	.321	.462	.562
	NC	< 15	< 25	< 30	< 35	35	> 40	> 40	> 40	> 40
	Throw - Radius (ft)	11	14	15	16	17	19	21	-	-
18" 450 mm	CFM	707	884	1060	1237	1414	1767	2121	2474	-
	Pressure Loss (in wg.)	.052	.064	.116	.157	.221	.361	.542	.803	-
	NC	< 20	< 25	< 30	< 35	< 40	> 40	> 40	> 40	-
	Throw - Radius (ft)	13	15	17	18	19	22	25	-	-
20" 500 mm	CFM	873	1091	1309	1527	1745	2182	2618	-	-
	Pressure Loss (in wg.)	.039	.060	.080	.100	.141	.233	.321	-	-
	NC	25	< 3	< 35	35	< 40	> 40	> 40	-	-
	Throw - Radius (ft)	13	15	17	19	21	25	29	-	-
Downward Projection of Heated Air (in ft)	10 Degrees F Diff.	6 - 6	8 - 8	10 - 12	13 - 15	15 - 19	19 - 25	21 - 32	25 - 38	27 - 40
	20 Degrees F Diff.	4 - 4	6 - 7	7 - 8	9 - 11	10 - 14	13 - 18	15 - 17	17 - 25	19 - 29
	30 Degrees F Diff.	3 - 3	5 - 5	6 - 7	7 - 9	9 - 11	11 - 15	13 - 18	14 - 20	15 - 24
	40 Degrees F Diff.	3 - 2	4 - 4	5 - 6	7 - 8	8 - 10	10 - 13	11 - 16	12 - 18	14 - 20

Performance Notes

- NC value based on 10 db room attenuation
- Throw values are based on isothermal air and terminal velocity of 40 fpm
- For exposed duct application, multiply throw values by 0.7
- Downward Projection of Heated Air values represent the distance to a total air velocity of essentially zero. The two values are for 6" neck and 12" neck. In horizontal position.

SQUARE DIFFUSERS



MODELS ISA, ISAI, ISAM ARCHITECTURAL PLAQUE DIFFUSERS

- MODEL **ISA** - Square neck
- MODEL **ISAM** - Round neck
- MODEL **ISAI** - Insulated

ISA Series supply diffusers are recommended for heating, ventilating and cooling.

The ISA series provide a 360° air diffusion pattern with an adjustable opening. The face panel can be adjustable by the means of four spring-loaded countersunk screws to increase or decrease the air throw.

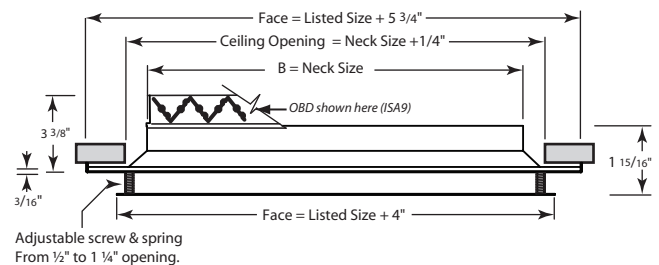
Features:

- Full Face 12"x12", 15"x15", 18"x18", 21"x21" and 24"x24"
- 1 Way, 2 Way Opposed, 2 Way Corner, 3 Way or 4 Way
- Commercial-grade aluminum construction
- Core can be easily removed without tools
- Ideal for VAV systems
- Powder paint coating - White (default) Custom colours avail.

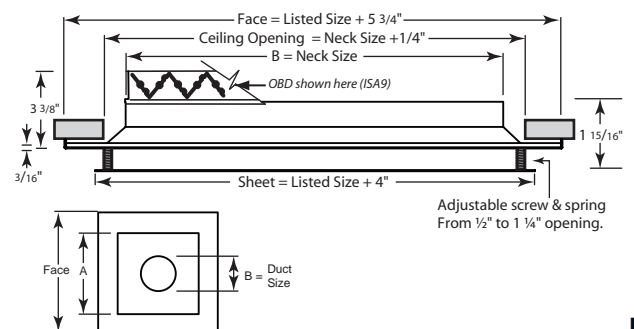


ISA

ISA/ISA9



ISAM/ISAM4/ISAM5



PERFORMANCE DATA

SERIES ISA

PLAQUE DIFFUSERS



6" x 6" Square Neck

Face Oppening (inches)	Neck Velocity (fpm)	165	250	335	420	625	830	1035	1240	1445
	Velocity Pressure (in H ₂ O)	.003	.005	.007	.011	.024	.041	.064	.091	.123
	Airflow, CFM	50	70	90	110	160	210	260	310	360
1.25"	Total Pressure				.04	.07	.11	.17	.24	.32
	NC				14	19	22	26	31	37
	Throw (ft)				1	3	5	6	7	9
1"	Total Pressure			.03	.04	.08	.12	.18	.27	.35
	NC			-	14	19	22	26	32	38
	Throw (ft)			1	2	4	6	7	9	11
0.75"	Total Pressure	.01	.02	.03	.04	.09	.14	.22	.31	.42
	NC	-	-	-	14	19	22	26	32	38
	Throw (ft)	1	2	3	4	5	7	8	9	11
0.5"	Total Pressure	.02	.03	.04	.06	.11	.29	.28	.42	.57
	NC	-	-	-	21	24	31	38	43	47
	Throw (ft)	2	3	4	5	6	8	9	10	12

9" x 9" Square Neck

Face Oppening (inches)	Neck Velocity (fpm)	94	144	193	287	381	474	568	751	845
	Velocity Pressure (in H ₂ O)	-	.001	.003	.005	.009	.013	.019	.032	.141
	Airflow, CFM	60	85	110	160	210	260	310	410	460
1.25"	Total Pressure				.02	.02	.04	.07	.11	.13
	NC				13	18	21	24	33	38
	Throw (ft)				2	3	5	6	8	10
1"	Total Pressure			.02	.03	.04	.06	.08	.13	.16
	NC			-	14	19	22	25	34	40
	Throw (ft)			2	4	5	6	7	10	12
0.75"	Total Pressure		.01	.02	.03	.05	.08	.11	.18	.22
	NC		-	-	15	20	23	36	36	41
	Throw (ft)		2	3	6	6	7	9	11	13
0.5"	Total Pressure	-	.01	.03	.05	.07	.13	.18	.30	.38
	NC	-	-	-	15	21	23	27	38	43
	Throw (ft)	2	3	4	6	7	9	10	13	14

12" x 12" Square Neck

Face Oppening (inches)	Neck Velocity (fpm)	55	110	165	220	275	330	435	540	650
	Velocity Pressure (in H ₂ O)	-	.001	.003	.004	.005	.007	.011	.016	.024
	Airflow, CFM	60	110	160	210	260	310	410	510	560
1.25"	Total Pressure			.01	.02	.03	.04	.05	.08	.10
	NC			-	14	19	22	26	31	37
	Throw (ft)			3	4	6	7	9	12	13
1"	Total Pressure		-	.01	.02	.04	.05	.07	.10	.13
	NC		-	-	14	18	22	26	32	38
	Throw (ft)		2	4	5	7	8	10	13	15
0.75"	Total Pressure		.01	.02	.04	.05	.07	.10	.16	.19
	NC		3	5	6	7	9	11	14	15
	Throw (ft)		-	-	14	19	23	28	36	38
0.5"	Total Pressure	-	.03	.04	.06	.08	.11	.19	.29	.35
	NC	-	-	-	15	21	24	31	39	46
	Throw (ft)	2	3	4	5	6	8	9	15	17

NC Value based on 10 db room attenuation.

Throw Values are based on isothermal air and terminal velocities of 150 fpm, 100 fpm & 75 fpm respectively
Total Pressure the sum of static pressure plus velocity pressure and is given in inches w.g.

PERFORMANCE DATA

SERIES ISA

PLAQUE DIFFUSERS



15" x 15" Square Neck

Face Opening (inches)	Neck Velocity (fpm)	37	74	111	148	215	286	355	424	493
	Velocity Pressure (in H ₂ O)	.001	.002	.002	.002	.003	.005	.007	.010	.014
	Airflow, CFM	50	100	150	200	300	400	500	600	700
1.25"	Total Pressure				.01	.02	.03	.05	.07	.10
	NC				-	19	23	27	34	40
	Throw (ft)				-	5	6	9	10	12
1"	Total Pressure			.03	.04	.08	.12	.18	.27	.35
	NC			-	14	20	24	29	36	43
	Throw (ft)			2	4	6	8	10	12	14
0.75"	Total Pressure		.01	.01	.02	.04	.08	.11	.15	.20
	NC		-	-	-	16	22	27	33	41
	Throw (ft)		2	4	5	8	11	13	15	17
0.5"	Total Pressure	.01	.02	.03	.04	.08	.14	.21	.29	.39
	NC	-	-	-	16	22	27	33	41	49
	Throw (ft)	2	3	5	6	9	12	15	18	21

18" x 18" Square Neck

Face Opening (inches)	Neck Velocity (fpm)	27	54	104	153	203	252	302	351	401
	Velocity Pressure (in H ₂ O)	.001	.002	.002	.002	.003	.004	.006	.007	.009
	Airflow, CFM	50	100	200	300	400	500	600	700	800
1.25"	Total Pressure			.01	.03	.04	.06	.08	.11	.14
	NC			-	15	21	23	19	34	41
	Throw (ft)			2	4	6	7	9	11	13
1"	Total Pressure			.02	.03	.04	.06	.08	.11	.14
	NC			-	15	21	25	29	36	44
	Throw (ft)			3	5	8	9	10	14	15
0.75"	Total Pressure	.01	.01	.02	.04	.06	.08	.13	.16	.21
	NC	-	-	-	16	22	26	32	38	47
	Throw (ft)	2	3	5	7	9	10	14	16	18
0.5"	Total Pressure	-	.01	.03	.06	.11	.15	.23	.30	.39
	NC	-	-	11	17	23	28	34	41	51
	Throw (ft)	2	4	6	9	12	14	17	19	21

NC Value based on 10 db room attenuation.

Throw Values are based on isothermal air and terminal velocities of 150 fpm, 100 fpm & 75 fpm respectively
Total Pressure the sum of static pressure plus velocity pressure and is given in inches w.g.

PERFORMANCE DATA

SERIES ISA/ISAM

PLAQUE DIFFUSERS



HOW TO ORDER ISA SERIES

ISA-3-A1-ES-Y2424 0606 /W

MODEL SERIES

Adjustable Plaque Diffusers **ISA**
 ...with OBD **ISA9**
 ...Insulated **ISAI**

FINISH (OPTIONAL)
 Standard is White (**/W**)
 See chart for more

MOUNTING (OPTIONAL)

Default is lay-In (-0),
 no need to specify
 Lay-In (default) **-0**
 Screw Holes in Face **-3**
 Concealed **-4**

NECK DIMENSIONS

In Inches
 6" x 6" **0606**
 9" x 9" **0909**
 12" x 12" **1212**
 15" x 15" **1515**
 18" x 18" **1818**

DIRECTION (OPTIONAL)

1 Baffle **-A1**
 2 Corner Baffles **-AC**
 2 Opposed Baffles **-AO**
 3 Baffles **-A3**
 4 Baffles **-A4**

FACE DIMENSIONS

12" x 24" **-Y1224**
 24" x 12" **-Y2412**
 24" x 24" **-Y2424**
 24" x 48" **-Y2448**
 48" x 24" **-Y4824**
 20" x 20" **-Y2020**

OPTION

Square equalizing grid **-ES**

HOW TO ORDER ISAM SERIES

ISAM-3-A1 R4 EG-Y2424 0606 06 /W

MODEL SERIES

Adjustable Plaque Diffusers **ISAM**
 ...with OBD **ISAM4**
 ...Insulated **ISAM5**

FINISH (OPTIONAL)
 Standard is White (**/W**)
 See chart for more

MOUNTING (OPTIONAL)

Default is lay-In (-0),
 no need to specify
 Lay-In (default) **-0**
 Screw Holes in Face **-3**
 Concealed **-4**

NECK DIMENSIONS

In Inches
 6" **06**
 8" **08**
 10" **10**
 12" **12**
 14" **14**

DIRECTION (OPTIONAL)

1 Baffle **-A1**
 2 Corner Baffles **-AC**
 2 Opposed Baffles **-AO**
 3 Baffles **-A3**
 4 Baffles **-A4**

NECK DIMENSIONS

In Inches
 6" x 6" **0606**
 9" x 9" **0909**
 12" x 12" **1212**
 15" x 15" **1515**
 18" x 18" **1818**

INSULATION (OPTIONAL)

Default is uninsulated,
 no need to specify
 R4.2 Taped Insulation **-R4**
 R6 Taped Insulation **-R6**

FACE DIMENSIONS

12" x 24" **-Y1224**
 24" x 12" **-Y2412**
 24" x 24" **-Y2424**
 24" x 48" **-Y2448**
 48" x 24" **-Y4824**
 20" x 20" **-Y2020**

OPTION

Square equalizing grid **-ES**

SQUARE DIFFUSERS



Rev. 6

ARCHITECTURAL PLAQUE DIFFUSERS

Square Face • 360° Air Distribution

PRODUCT MODELS

Steel Construction

ISO – Round neck

ISOD – 2" high collar, single-box

ISOI – insulated (-R6 standard) - Pre-scored for collars

Aluminum Construction

AISO – Aluminum version of ISO

AISOD – Aluminum version with 2" high collar

AISOI – Aluminum insulated version

-R4 and **-R6** insulation options available on select models.

The Airvector® **ISO** Series supply diffusers are designed for heating, ventilating, and cooling applications requiring quiet, efficient, and uniform air distribution. Featuring a round-neck-to-square-face geometry, **ISO** plaque diffusers deliver a true 360° horizontal air diffusion pattern comparable to full round diffusers, while preserving a clean, architectural square ceiling appearance.

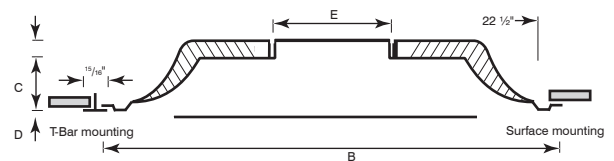
High induction diffusion promotes rapid temperature and velocity equalization of the mixed air mass well above the occupied zone. This performance allows confident use in cooling applications with temperature differentials up to 30°, while maintaining low air motion levels of approximately 35 fpm within the occupied zone.

ISO Series supply diffusers perform efficiently with air loadings ranging from 6 to 30 air changes per hour (based on a 10 ft ceiling height) and operate within a sound level range of NC 25 to 35. Available in painted steel or aluminum construction, the **ISO** Series provides flexibility to meet performance, weight, and corrosion-resistance requirements across a wide range of commercial installations.

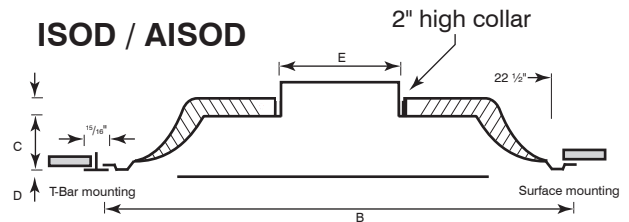


ISO

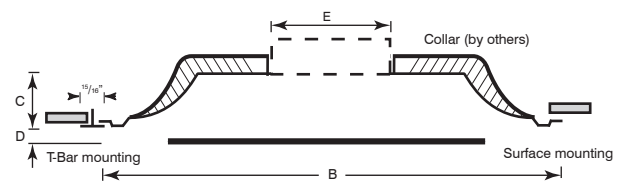
ISO / AISO



ISOD / AISOD



ISOI / AISOI



Model	Nominal Face Size	Overall Face Size B x B
ISOI	24 x 24	23 ³ / ₄ x 23 ³ / ₄



ISOI fiberglass back.

DATA SHEET

SQUARE DIFFUSERS



Rev. 1

ISO/AISO SERIES ARCHITECTURAL PLAQUE DIFFUSERS

HOW TO ORDER ISO/AISO SERIES

Square Face • 360° Air Distribution

KEY FEATURES (ALL MODELS)

- **Universal Ceiling Compatibility**

One standard model suits both T-bar and drywall installations using rigid ducts; compatible with Airvector PF Easy Install Frame.

- **Service-Friendly Design**

Tool-free removable core allows easy access to duct and optional damper.

- **360° Horizontal Air Distribution**

Uniform diffusion across the ceiling plane for balanced comfort.

- **High Induction Performance**

Rapid mixing and temperature equalization above the occupied zone.

- **Quiet Operation**

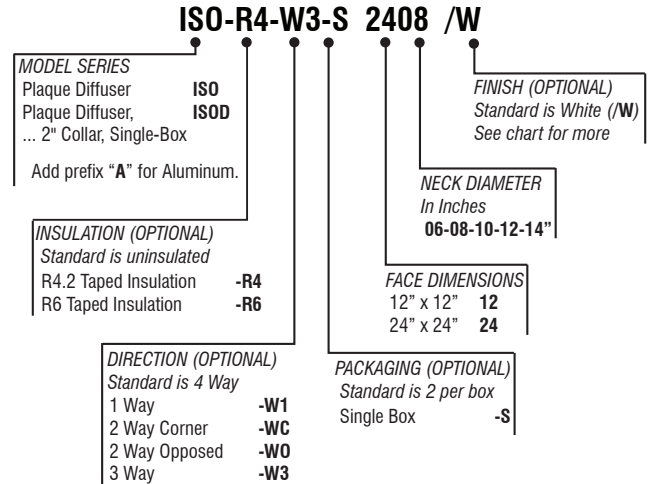
Engineered for low sound levels in comfort-driven environments.

- **Steel or Aluminum Heavy-Gauge Construction**

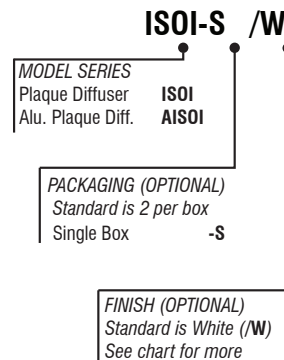
Painted steel or aluminum options to suit project needs.

OPTIONS & ACCESSORIES

- Standard white powder-coated finish; custom colors available.
- Optional **-R4** or **-R6** insulation (**-R6** standard on **ISOI / AISOI**)
- Compatible **N4 / N5** opposed blade dampers, adjustable from the face.
- **NBI** balancing baffle
- **PF** Easy Install Frame for drywall ceilings.
- Single-box packaging.



HOW TO ORDER ISOI/AISOI



ISO Model Size	Neck Dia.	Nominal Face Size	Overall Face Size B x B	Drywall Ceiling Opening
1206	6	12 x 12	11 ³ / ₄ x 11 ³ / ₄	10 ¹ / ₂ x 10 ¹ / ₂
1208	8	12 x 12	11 ³ / ₄ x 11 ³ / ₄	10 ¹ / ₂ x 10 ¹ / ₂
2406	6	24 x 24	23 ³ / ₄ x 23 ³ / ₄	22 ¹ / ₂ x 22 ¹ / ₂
2408	8	24 x 24	23 ³ / ₄ x 23 ³ / ₄	22 ¹ / ₂ x 22 ¹ / ₂
2410	10	24 x 24	23 ³ / ₄ x 23 ³ / ₄	22 ¹ / ₂ x 22 ¹ / ₂
2412	12	24 x 24	23 ³ / ₄ x 23 ³ / ₄	22 ¹ / ₂ x 22 ¹ / ₂
2414	14	24 x 24	23 ³ / ₄ x 23 ³ / ₄	22 ¹ / ₂ x 22 ¹ / ₂

DATA SHEET

ISO, ISOD, ISOI (steel) / AISO, AISOD, AISOI (aluminum)
Plaque Diffusers

12" x 12" face

SIZE (inches)	Neck Velocity (fpm)	400	500	600	700	800	1000	1200	1400	1600
	Velocity Pressure (in H ₂ O)	.010	.016	.022	.031	.041	.062	.090	.122	.160
6	CFM	78	98	118	137	157	196	235	274	313
	Total Pressure	.05	.07	.10	.14	.18	.29	.41	.58	.72
	NC	< 20	< 20	< 20	< 20	< 20	21	24	29	37
	Throw (ft)	2-3-6	3-4-7	4-5-9	4-5-10	5-6-11	6-8-12	7-9-13	8-10-15	9-11-16
8	CFM	140	175	209	244	279	349	419	489	559
	Total Pressure	.07	.10	.15	.21	.29	.42	.62	.84	1.00
	NC	< 20	< 20	< 20	< 20	< 20	25	30	38	45
	Throw (ft)	2-4-7	3-5-9	4-7-10	5-8-11	6-9-12	7-10-14	8-12-17	10-12-18	11-14-20

24" x 24" face

SIZE (inches)	Neck Velocity (fpm)	400	500	600	700	800	1000	1200	1400	1600
	Velocity Pressure (in H ₂ O)	.010	.016	.022	.031	.041	.062	.090	.122	.160
6	CFM	78	98	118	137	157	196	235	274	313
	Total Pressure	.02	.03	.04	.05	.08	.1	.14	.19	.24
	NC	< 20	< 20	< 20	< 20	< 20	23	27	32	37
	Throw (ft)	1-2-4	2-3-4	2-3-5	2-3-6	3-4-7	4-5-8	4-6-9	4-7-10	6-8-14
8	CFM	140	175	209	244	279	349	419	489	559
	Total Pressure	.02	.03	.04	.06	.08	.11	.17	.23	.29
	NC	< 20	< 20	< 20	< 20	< 20	28	32	36	41
	Throw (ft)	2-3-5	2-3-7	3-4-8	3-5-8	4-6-9	5-7-11	6-8-14	7-9-14	7-10-14
10	CFM	218	273	327	382	436	545	654	763	872
	Total Pressure	.03	.04	.06	.08	.11	.18	.24	.35	.48
	NC	< 20	< 20	< 20	< 20	23	29	36	40	44
	Throw (ft)	3-4-6	4-5-8	4-6-10	5-7-12	6-8-14	7-9-15	8-11-16	9-12-17	10-13-19
12	CFM	314	393	471	550	628	785	941	1099	1246
	Total Pressure	.04	.06	.08	.13	.16	.25	.35	.50	.67
	NC	< 20	< 20	< 20	21	24	31	38	43	47
	Throw (ft)	4-5-9	5-6-10	6-7-10	6-8-13	7-9-15	8-11-18	10-13-20	11-15-21	12-16-22
14	CFM	492>	615	738	861	984	1230	1476	1722	1968
	Total Pressure	.05	.08	.13	.16	.22	.32	.43	.59	.80
	NC	< 20	< 20	< 20	22	27	34	40	43	47
	Throw (ft)	4-6-10	5-6-11	6-8-14	7-10-16	8-11-18	10-14-20	12-15-22	12-17-23	14-19-24

NC Value based on 10 db room attenuation.

Throw Values are based on isothermal air and terminal velocities of 150 fpm, 100 fpm & 75 fpm respectively.
 Total Pressure the sum of static pressure plus velocity pressure and is given in inches w.g.

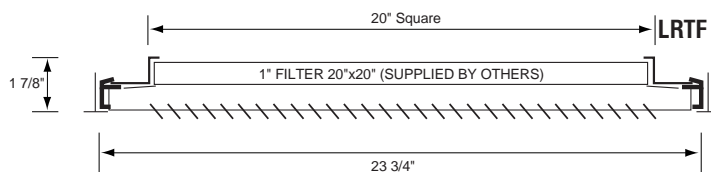
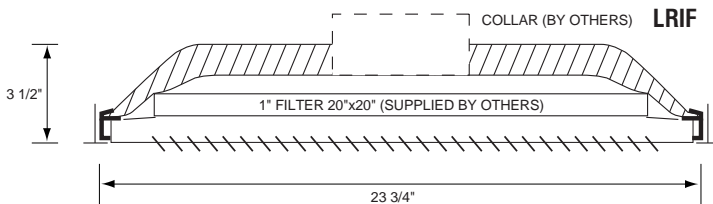
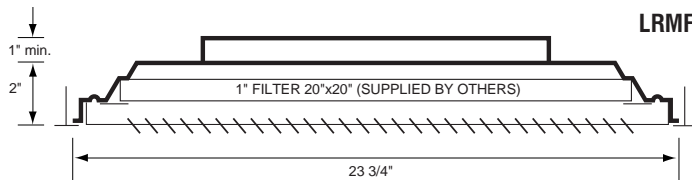
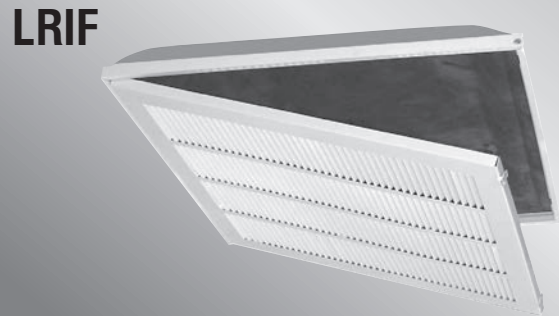
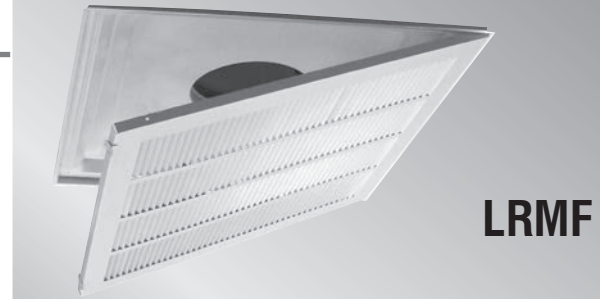
MODELS LRMF-LRIF-LRTF FOR TEE BAR LAY-IN INSTALLATIONS

Series **LR** filter grilles have their face lanced with rows of fins capable of transferring or returning high air volumes with minimum air pressure loss. The fins are set at 40° and spaced 1/2" apart. The face swings in or out of the fixed back pan for easy access to the 1" standard filter or filter media (supplied by others). Two locking arms opposite to the two concealed hinges provide secure locking of the face in an unobtrusive manner.

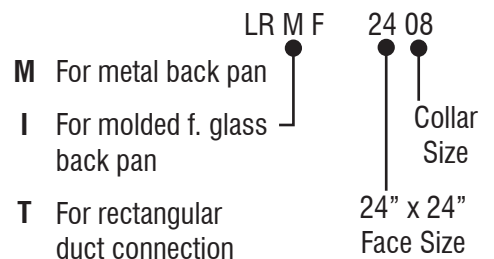
Model **LRMF** has steel back pan with heavy gauge steel reinforcing corners equivalent to 18 ga. so as to minimize damage due to handling.

Model **LRIF** has an insulated back pan consisting of a fixed extruded aluminum frame and a molded fiberglass pan suitable for round duct connections up to 14" D. and scored for easy cutting of collar opening. This model has sturdy corners so as to minimize damage due to handling.

Model **LRTF** has a square filter frame to accommodate 20" x 20" filters and ducts of the same listed size. This model has sturdy corners so as to minimize damage due to handling.



HOW TO ORDER



Perforated PRE/PRE7, PRT, PRN Series

Nominal Duct Size (in.)	Ak	Core Area sq. ft	Core Velocity Velocity Pressure Neg. Static Pressure	300		400		500		600		700		800		1000		1200		1400	
				0.010 0.051	0.016 0.079	0.022 0.114	0.031 0.156	0.040 0.203	0.062 0.318	1000 0.090 0.458	1200 0.122 0.623	1400 0.162 0.823	NC 10	NC 20	NC 30	NC 40					
6x6	0.20	0.19	Airflow, cfm NC	57 -	76 -	95 -	114 -	133 13	152 16	190 21	228 26	266 30									
8x6	0.27	0.2	Airflow, cfm NC	78 -	104 -	130 -	156 -	182 14	208 17	260 22	312 27	364 30									
10x6	0.33	0.34	Airflow, cfm NC	102 -	136 -	170 -	204 11	238 15	272 18	340 24	408 28	476 32									
8x8	0.36	0.37	Airflow, cfm NC	111 -	148 -	185 -	222 12	259 15	296 19	370 24	444 29	518 33									
12x6	0.40	0.41	Airflow, cfm NC	123 -	164 -	205 -	246 12	287 16	328 19	410 25	492 29	574 33									
12x8	0.53	0.75	Airflow, cfm NC	171 -	228 -	285 -	342 14	399 17	456 21	570 27	684 31	798 34									
10x10	0.56	0.59	Airflow, cfm NC	177 -	236 -	295 -	354 14	413 18	472 21	590 26	708 31	826 35									
18x6	0.60	0.63	Airflow, cfm NC	189 -	252 -	315 -	378 15	441 18	504 22	630 27	756 31	882 35									
12x10	0.67	0.72	Airflow, cfm NC	216 -	288 -	360 -	432 15	504 18	576 22	720 27	864 32	1008 35									
12x12	0.80	0.88	Airflow, cfm NC	264 -	352 -	440 11	528 15	616 19	704 23	880 28	1056 31	1232 36									
14x14	1.09	1.22	Airflow, cfm NC	366 -	488 -	610 12	732 16	854 21	976 24	1220 29	1464 34	1708 38									
18x12	1.20	1.35	Airflow, cfm NC	405 -	540 -	675 12	810 17	945 21	1080 24	1350 30	1620 34	1890 38									
24x10	1.33	1.49	Airflow, cfm NC	447 -	596 -	745 12	894 18	1043 22	1192 25	1490 30	1788 35	2086 39									
16x16	1.42	1.62	Airflow, cfm NC	486 -	648 -	810 14	972 18	1134 22	1296 25	1620 31	1944 35	2268 39									
24x12	1.60	1.82	Airflow, cfm NC	546 -	728 -	910 14	1092 19	1274 22	1456 26	1820 30	2184 36	2548 39									
18x18	1.80	2.07	Airflow, cfm NC	621 -	828 -	1035 15	1242 19	1449 23	1656 26	2070 32	2484 36	2898 40									
30x12	2	2.29	Airflow, cfm NC	687 -	916 -	1145 15	1374 20	1603 23	1832 27	2290 32	2748 37	3206 40									
20x20	2.22	2.57	Airflow, cfm NC	771 -	1028 -	1285 16	1542 20	1799 24	2056 27	2570 33	3084 37	3598 41									
22x22	2.69	3.14	Airflow, cfm NC	942 -	1256 11	1570 17	1884 21	2198 25	2512 28	3140 34	3768 38	4396 42									
30x18	3	3.5	Airflow, cfm NC	1050 -	1400 12	1750 17	2100 21	2450 25	2800 29	3500 34	4200 38	4900 42									
24x24	3.20	3.75	Airflow, cfm NC	1125 -	1500 12	1875 17	2250 22	2625 26	3000 29	3750 34	4500 39	5250 43									
36x18	3.60	4.22	Airflow, cfm NC	1266 -	1688 12	2110 18	2532 22	2954 26	3376 29	4220 35	5064 39	5908 43									
26x26	3.76	4.47	Airflow, cfm NC	1341 -	1788 12	2235 18	2682 22	3129 26	3576 29	4025 35	4470 39	5364 43									
30x24	4	4.71	Airflow, cfm NC	1413 -	1884 13	2355 18	2826 23	3297 27	3768 30	4710 35	5652 40	6594 44									

Static pressures are negative, in inches of water,

SYMBOLS

NC Noise Criteria based on room absorption of 10dB

Ak Outlet area in Sq. Feet

Perforated PRE/PRE7, PRT, PRN Series

Nominal Duct Size (in.)	Ak	Core Area sq. ft	Core Velocity Velocity Pressure Neg. Static Pressure	NC 10		NC 20		NC 30		NC 40		NC 50	
				300 0.010 0.051	400 0.016 0.079	500 0.022 0.114	600 0.031 0.156	700 0.040 0.203	800 0.062 0.318	1000 0.090 0.458	1200 0.122 0.623	1400 0.12 0.62	
28x28	4.36	5.16	Airflow, cfm NC	1548 -	2064 13	2580 19	3096 22	3612 27	4128 30	5160 36	6192 40	7224 44	
36x24	4.8	5.66	Airflow, cfm NC	1698 -	2264 13	2830 19	3396 24	3962 27	4528 31	5660 36	6792 41	7924 44	
30x30	5	5.94	Airflow, cfm NC	1782 -	2376 14	2970 19	3564 22	4158 28	4752 31	5940 36	7128 41	8316 45	
32x32	5.69	6.78	Airflow, cfm NC	2034 -	2712 14	3390 20	4068 24	4746 28	5424 31	6780 37	8136 41	9492 45	
48x24	6.4	7.63	Airflow, cfm NC	2289 -	3052 15	3815 20	4578 25	5341 29	6104 32	7630 38	9156 42	10682 46	
36x36	7.4	8.63	Airflow, cfm NC	2589 -	3452 15	4315 22	5178 25	6041 29	6904 32	8630 38	10356 42	12082 46	
38x38	8.02	9.64	Airflow, cfm NC	2892 -	3856 16	4820 21	5784 26	6748 30	7712 33	9640 38	11568 43	13496 47	
40x40	8.89	10.70	Airflow, cfm NC	3210 -	4280 16	5350 22	6420 26	7490 30	8560 34	10700 39	12840 43	14980 47	
42x42	9.8	11.82	Airflow, cfm NC	3546 -	4728 17	5910 22	7092 27	8274 31	9456 34	11820 39	14184 43	16548 48	
44x44	10.76	12.99	Airflow, cfm NC	3897 -	5196 17	6495 23	7794 27	9093 31	10392 34	12990 40	15588 44	18186 48	
46x46	11.76	14.22	Airflow, cfm NC	4266 11	5688 18	7110 23	8532 28	9954 31	11376 35	14220 40	17064 45	19908 48	
48x48	12.80	15.50	Airflow, cfm NC	4650 11	6200 18	7750 23	9300 28	10850 32	12400 35	15500 40	18600 45	21700 49	

Static pressures are negative, in inches of water,

SYMBOLS

NC Noise Criteria based on room absorption of 10dB

Ak Outlet area in Sq. Feet

MODELS PRMF-PRIF-PRTF

FOR TEE BAR LAY-IN INSTALLATIONS

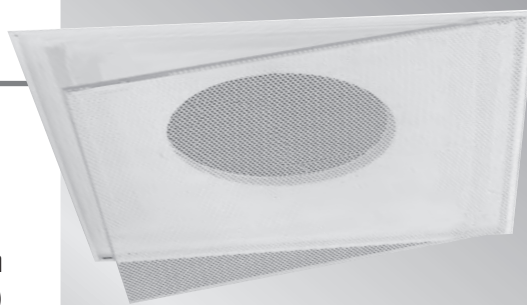
Series **PR** filter grilles match in appearance perforated face supply diffusers series PS.

The grille consists of a heavy gauge steel perforated face with 3/16" D. round holes on 1/4" staggered centers (53% free area) which swings in or out of the fixed back pan for easy access to the 1" filter 20" x 20" (supplied by others). Two locking arms opposite to the two concealed hinges provide secure locking of the grille in an unobtrusive manner.

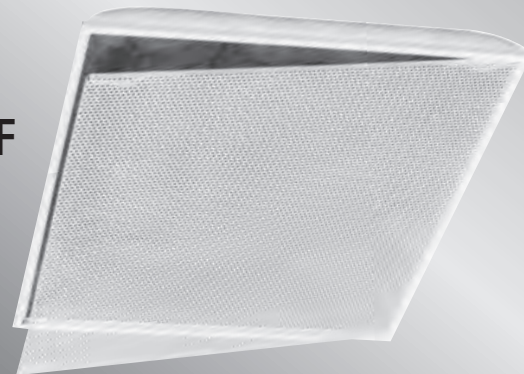
Model **PRMF** has steel back pan with 20" x 20" square filter frame, heavy gauge steel reinforcing corners equivalent to 18 ga. so as to minimize damage due to handling. Extruded round collars will accommodate ducts 6", 8", 10", 12" & 14" D.

Model **PRIF** has an insulated back pan consisting of a fixed extruded aluminum frame and a molded fiberglass pan suitable for round ducts connections up to 14" D. and scored for easy cutting of collar opening. The extruded aluminum frame has sturdy corners so as to minimize damage due to handling.

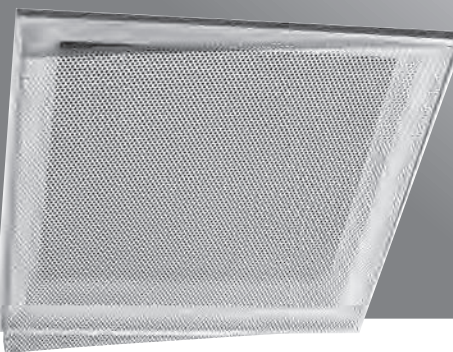
Model **PRTF** has a square filter frame to accommodate 1" filters 20" x 20" and ducts of same listed size. The extruded aluminum frame has sturdy corners so as to minimize damage due to handling.



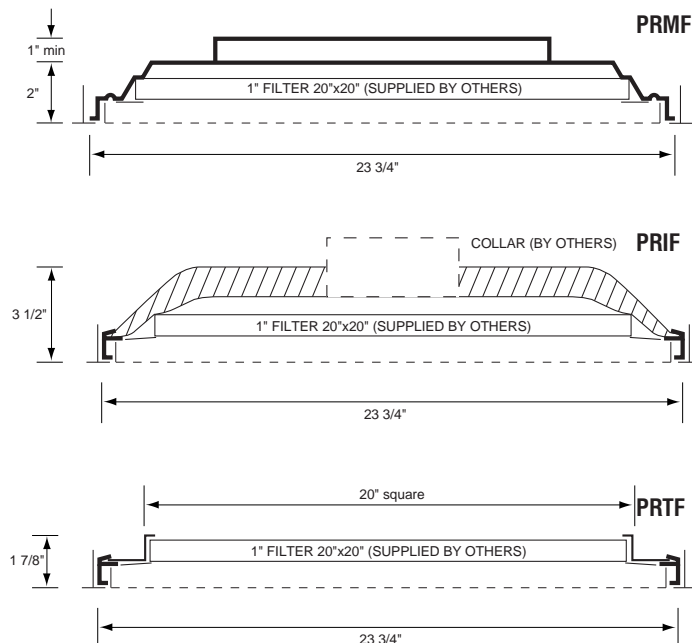
PRMF



PRIF



PRTF



HOW TO ORDER

M For metal back pan	PRMF	2408	Collar Size
I For molded f. glass back pan			
T For rectangular duct connection		24" x 24"	Face Size

DATA SHEET

PERFORATED DIFFUSERS



MODELS PSI , PSIL & PRI with R6 Plenum

MODELS PSI & PSIL - Supply Diffusers

PSI Supply Diffusers have high diffusion induction rates resulting in rapid temperature and velocity equalization of the mixed air mass well above the zone of occupancy.

The horizontal performance of their air pattern baffle or optional directional louvers ensure confident use of cooling differentials of 25° F and greater, at predicted low air motion 35 fpm in the zone of occupancy.

PSI Supply Diffusers perform efficiently with air loadings of 1 to 3 cfm per square feet of floor area, or 6 to 20 air changes per hour (based on 10 ft. ceiling height) and sound level range of NC 25 to 35.



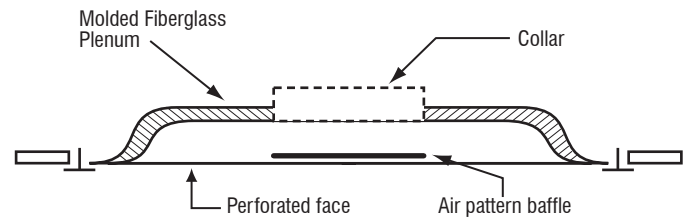
**PSI
PSIL
PRI**

MODEL PRI - Return Diffusers

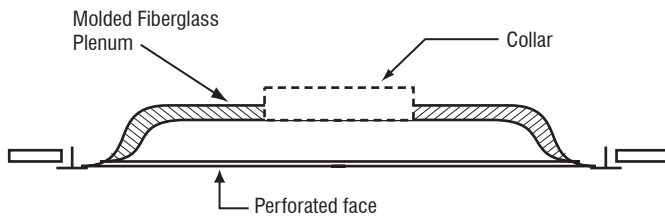
PRI Return Diffusers are similar to PSI but with the air pattern baffle removed. They are matched in appearance.

FEATURES

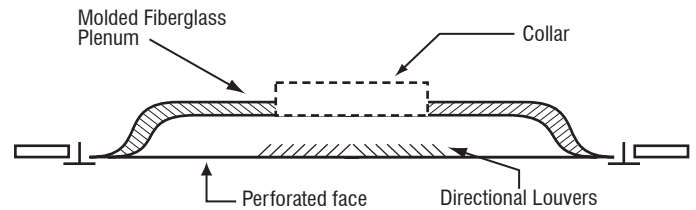
- Heavy gauge all steel construction.
- 24" X 24" face for neck sizes 6"-8"-10"-12"-14" D.
- Compatible with VAV Systems.
- Powder paint coating - White.
- Holes are $\frac{3}{16}$ " D. staggered $\frac{1}{4}$ " affording 53% free area.



Model PSI Standard - with Air Pattern Baffle



Model PRI - No Baffle



Model PSIL - with Directional Louvers

HOW TO ORDER		
	PSI	/W
<i>MODEL SERIES</i>		
Supply - Round Baffle	PSI	<i>FINISH (OPTIONAL)</i>
Supply - Directional Baffles	PSIL	<i>Standard is White (/W)</i>
Return	PRI	<i>See chart for more</i>

ENGINEERING PERFORMANCE DATA



MODEL PSI & PSIL - Supply Diffusers

24" x 24" face

NECK SIZE	Neck Velocity (fpm)	400	500	600	700	800	1000	1200	1400
	Velocity Pressure (in H ₂ O)	.010	.016	.022	.031	.041	.062	.090	.122
6"	CFM	78	98	118	137	157	196	235	274
	Total Pressure	.017	.027	.038	.053	.069	.109	.159	.215
	NC	< 20	< 20	< 20	21	27	32	37	41
	Throw (ft)	1-2-3	1-2-4	2-3-5	2-3-6	2-4-7	3-5-8	4-6-9	5-7-10
8"	CFM	140	175	209	244	279	349	419	489
	Total Pressure	.018	.028	.040	.054	.071	.109	.160	.216
	NC	< 20	< 20	< 20	24	27	33	37	42
	Throw (ft)	1-3-5	2-3-6	2-4-7	3-5-8	4-6-10	5-8-12	6-9-14	7-10-15
10"	CFM	218	273	327	382	436	545	654	763
	Total Pressure	.018	.026	.039	.054	.071	.109	.160	.216
	NC	< 20	< 20	< 20	23	28	36	41	47
	Throw (ft)	2-4-6	3-4-7	3-5-8	4-7-10	5-8-12	5-9-14	6-11-16	7-13-18
12"	CFM	314	393	471	550	628	785	941	1099
	Total Pressure	.019	.029	.041	.057	.072	.111	.163	.218
	NC	< 20	< 20	20	25	30	39	43	49
	Throw (ft)	2-5-7	3-5-8	3-7-10	4-8-12	5-9-14	7-11-16	8-12-18	10-14-21
14"	CFM	492	615	738	861	984	1230	1476	1722
	Total Pressure	.021	.032	.043	.075	.092	.141	.193	.261
	NC	< 20	< 20	21	26	34	40	45	50
	Throw (ft)	3-6-9	4-7-10	4-8-12	5-9-13	6-10-15	8-12-18	10-14-21	12-17-24

NC Value based on 10 db room attenuation.

Throw Values are based on isothermal air and thermal velocities of 150 fpm, 100 fpm & 75 fpm respectively.
Total Pressure the sum of static pressure plus velocity pressure and is given in inches w.g.

MODEL PRI - Return Diffusers

24" x 24" face

NECK SIZE	Neck Velocity (fpm)	400	500	600	700	800	1000	1200	1400
	Velocity Pressure (in H ₂ O)	0.010	0.015	0.022	0.031	0.040	0.062	0.090	0.122
	Static Pressure (in H ₂ O)	-0.026	-0.042	-0.060	-0.078	-0.104	-0.160	-0.212	-0.290
6"	CFM	78	98	118	13	15	196	235	27
	NC	< 20	< 20	< 20	< 20	< 20	20	23	26
8"	CFM	140	175	209	244	279	349	419	489
	NC	< 20	< 20	< 20	21	22	24	27	29
10"	CFM	218	273	327	382	436	545	654	763
	NC	< 20	< 20	21	23	25	28	30	32
12"	CFM	314	393	471	550	628	785	941	1099
	NC	< 20	20	24	26	28	31	34	36
14"	CFM	430	534	642	748	858	1072	1286	1500
	NC	22	25	28	30	32	35	37	39
16"	CFM	558	698	836	978	1110	1390	1666	1950
	NC	26	28	30	34	37	40	43	46

PERFORATED DIFFUSERS



MODELS PSM, PSML & PRM with Metal Plenum

MODELS PSM & PSML - Supply Diffusers

PSM Supply Diffusers have high diffusion induction rates resulting in rapid temperature and velocity equalization of the mixed air mass well above the zone of occupancy.

The horizontal performance of their standard air pattern baffle or optional directional louvers ensure confident use of cooling differentials of 25°F and greater at predicted low air motion 35 fpm in the zone of occupancy.

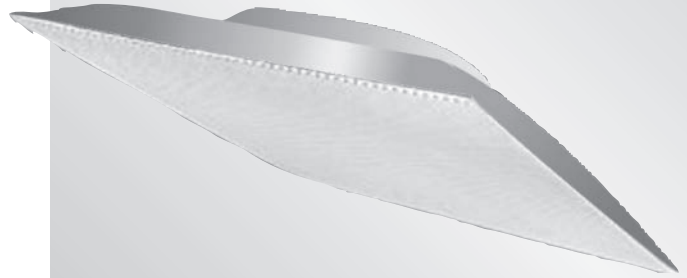
PSM Supply diffusers perform efficiently with air loadings of 1 to 3 cfm per square feet of floor area, or 6 to 20 air changes per hour (based on 10 ft. ceiling height) and sound level range of NC 25 to 35.

MODEL PRM - Return Diffusers

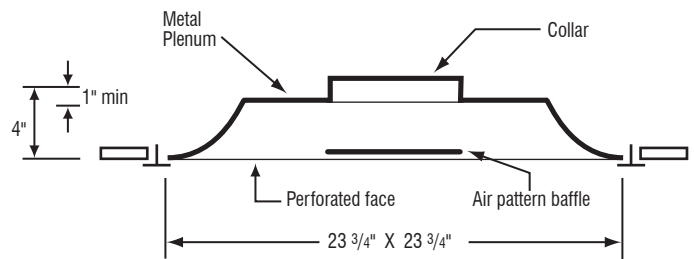
PRM Return Diffusers are similar to PSM but with the air pattern baffle removed. They are matched in appearance.

FEATURES

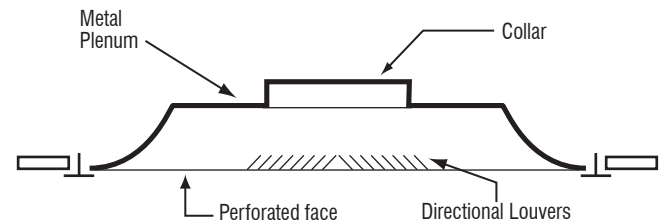
- Heavy gauge all steel construction.
- 24" X 24" face for neck sizes 6"-8"-10"-12"-14" D.
- Compatible with VAV Systems.
- Powder paint coating - White.
- Holes are $\frac{3}{16}$ " D. staggered $\frac{1}{4}$ " affording 53% free area.



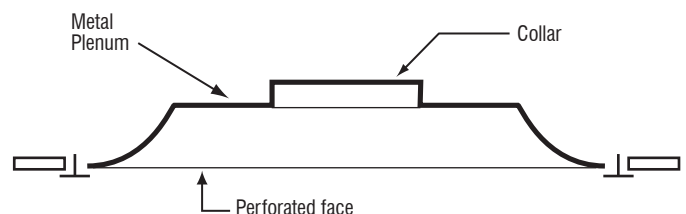
PSM
PSML
PRM



Model PSM - with Air Pattern Baffle



Model PSML - with Directional Louvers



Model PRM - No Baffles

HOW TO ORDER PSM SERIES

PSM-R4-S 2408 /W

MODEL SERIES	PSM
Supply - Round Baffle	PSML
Supply - Directional Baffles	PRM
Return	

FINISH (OPTIONAL)
Standard is White (/W)
See chart for more

NECK DIAMETER
In Inches
06-08-10-12-14"

FACE DIMENSIONS
24" x 24" **24**

INSULATION (OPTIONAL)
Standard is uninsulated

R4.2 Taped Insulation	-R4
R6 Taped Insulation	-R6

PACKAGING (OPTIONAL)
Standard is 2 per box
Single Box **-S**

ENGINEERING PERFORMANCE DATA



MODEL PSM - Supply Diffusers

24" x 24" face

NECK SIZE	Neck Velocity (fpm)	400	500	600	700	800	1000	1200	1400
	Velocity Pressure (in H ₂ O)	.010	.016	.022	.031	.041	.062	.090	.122
6"	CFM	78	98	118	137	157	196	235	274
	Total Pressure	.017	.027	.038	.053	.069	.109	.159	.215
	NC	< 20	< 20	< 20	21	27	32	37	41
	Throw (ft)	1-2-3	1-2-4	2-3-5	2-3-6	2-4-7	3-5-8	4-6-9	5-7-10
8"	CFM	140	175	209	244	279	349	419	489
	Total Pressure	.018	.028	.040	.054	.071	.109	.160	.216
	NC	< 20	< 20	< 20	24	27	33	37	42
	Throw (ft)	1-3-5	2-3-6	2-4-7	3-5-8	4-6-10	5-8-12	6-9-14	7-10-15
10"	CFM	218	273	327	382	436	545	654	763
	Total Pressure	.018	.026	.039	.054	.071	.109	.160	.216
	NC	< 20	< 20	< 20	23	28	36	41	47
	Throw (ft)	2-4-6	3-4-7	3-5-8	4-7-10	5-8-12	5-9-14	6-11-16	7-13-18
12"	CFM	314	393	471	550	628	785	941	1099
	Total Pressure	.019	.029	.041	.057	.072	.111	.163	.218
	NC	< 20	< 20	20	25	30	39	43	49
	Throw (ft)	2-5-7	3-5-8	3-7-10	4-8-12	5-9-14	7-11-16	8-12-18	10-14-21
14"	CFM	492	615	738	861	984	1230	1476	1722
	Total Pressure	.021	.032	.043	.075	.092	.141	.193	.261
	NC	< 20	< 20	21	26	34	40	45	50
	Throw (ft)	3-6-9	4-7-10	4-8-12	5-9-13	6-10-15	8-12-18	10-14-21	12-17-24

NC Value based on 10 db room attenuation.

Throw Values are based on isothermal air and terminal velocities of 150 fpm, 100 fpm & 75 fpm respectively.
Total Pressure the sum of static pressure plus velocity pressure and is given in inches w.g.

MODEL PRM - Return Diffusers

24" x 24" face

NECK SIZE	Neck Velocity (fpm)	400	500	600	700	800	1000	1200	1400
	Velocity Pressure (in H ₂ O)	0.010	0.015	0.022	0.031	0.040	0.062	0.090	0.122
	Static Pressure (in H ₂ O)	-0.026	-0.042	-0.060	-0.078	-0.104	-0.160	-0.212	-0.290
6"	CFM	78	98	118	13	15	196	235	27
	NC	< 20	< 20	< 20	< 20	< 20	20	23	26
8"	CFM	140	175	209	244	279	349	419	489
	NC	< 20	< 20	< 20	21	22	24	27	29
10"	CFM	218	273	327	382	436	545	654	763
	NC	< 20	< 20	21	23	25	28	30	32
12"	CFM	314	393	471	550	628	785	941	1099
	NC	< 20	20	24	26	28	31	34	36
14"	CFM	430	534	642	748	858	1072	1286	1500
	NC	22	25	28	30	32	35	37	39
16"	CFM	558	698	836	978	1110	1390	1666	1950
	NC	26	28	30	34	37	40	43	46

ENGINEERING PERFORMANCE DATA



MODEL PST - Supply Diffusers

24" x 24" face

NECK SIZE	Neck Velocity (fpm)	400	500	600	700	800	1000	1200	1400
	Velocity Pressure (in H ₂ O)	.010	.016	.022	.031	.041	.062	.090	.122
8 x 8"	CFM	198	222	267	311	356	444	593	682
	Total Pressure	.018	.026	.039	.054	.071	.109	.160	.216
	NC	< 20	< 20	< 20	23	28	36	41	47
	Throw (ft)	2-4-6	3-4-7	3-5-8	4-7-10	5-8-12	5-9-14	6-11-16	7-13-18
10 x 10"	CFM	278	347	417	486	556	625	822	972
	Total Pressure	.019	.029	.041	.057	.072	.111	.163	.218
	NC	< 20	< 20	20	25	30	39	43	49
	Throw (ft)	2-5-7	3-5-8	3-7-10	4-8-12	5-9-14	7-11-16	8-12-18	10-14-21
12 x 12"	CFM	400	500	600	700	800	1000	1200	1400
	Total Pressure	.021	.032	.043	.075	.092	.141	.193	.261
	NC	< 20	< 20	21	26	34	40	45	50
	Throw (ft)	3-6-9	4-7-10	4-8-12	5-9-13	6-10-15	8-12-18	10-14-21	12-17-24
14 x 14"	CFM	544	680	817	953	1088	1360	1633	1405
	Total Pressure	.023	.034	.092	.078	.096	.149	.201	.272
	NC	< 20	20	23	27	36	43	49	47
	Throw (ft)	4-7-11	5-9-12	5-9-14	6-10-14	7-11-16	9-13-20	12-16-24	14-20-27

MODEL PRT- Return Diffusers

24" x 24" face

NECK SIZE	Neck Velocity (fpm)	400	500	600	700	800	1000	1200	1400
	Velocity Pressure (in H ₂ O)	0.010	0.015	0.022	0.031	0.040	0.062	0.090	0.122
	Static Pressure (in H ₂ O)	-0.026	-0.042	-0.060	-0.078	-0.104	-0.160	-0.212	-0.290
12 x 12"	CFM	430	534	642	748	858	1072	1286	1500
	NC	22	25	26	28	32	35	37	39
14 x 14"	CFM	558	698	836	978	1110	1390	1666	1950
	NC	24	26	28	29	30	38	40	42
16 x 16"	CFM	712	961	1156	1345	1448	1932	2320	270
	NC	26	28	30	32	34	40	43	46
18 x 18"	CFM	900	1125	1350	1575	1700	2250	2700	3150
	NC	27	29	30	35	38	41	44	47

Exclusive Warranty for Airvector® Aluminum and Powder Coated Steel Grilles, Registers & Diffusers

Limited Warranty - Airvector® for aluminum or powder coated steel grilles, registers and diffusers.

Alfa Mega Inc. manufacturer of Airvector® products warrants to the owners of Airvector® products that, should rust become visible on the exposed portion of Airvector® aluminum or powder coated steel grilles, registers or diffusers, Airvector® will replace the rusted product. This warranty does not cover products affected by accidental or intentional damages, chemicals or misuse, including, without limitation, failure to perform necessary and reasonable maintenance.

The rusted unit must be shipped by the owner at its cost to Airvector® for replacement. Airvector® will cover the cost of replacement, including the cost of shipment back to the owner. Airvector® will not cover other charges, including costs of removal, handling or installation. A reasonable time should be allowed for replacement of the rusted unit. In case of a discontinued product, Airvector® will replace it with its closest equivalent.

This warranty is for five (5) years from the date of the shipment by Airvector®. This is the only warranty given with the purchase. Any warranties implied by law are limited to sixty (60) months from the date of shipment by Airvector®. Airvector® neither assumes nor authorizes any person or entity to assume for it any other liability in connection with any product covered by this agreement.

No payment or other compensation will be made for indirect or consequential damage such as, damage or injury to person or property or loss of revenue or profit which might be paid, incurred or sustained by reason of the use of inability to use a Airvector® product, even if such loss or damage could have been foreseen by Airvector®.

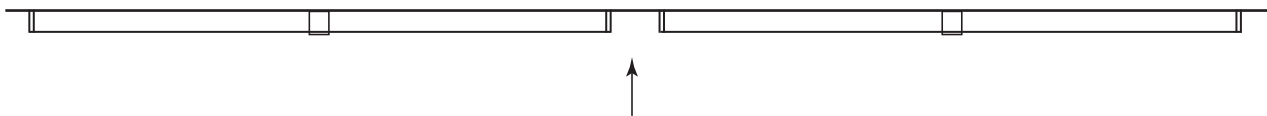
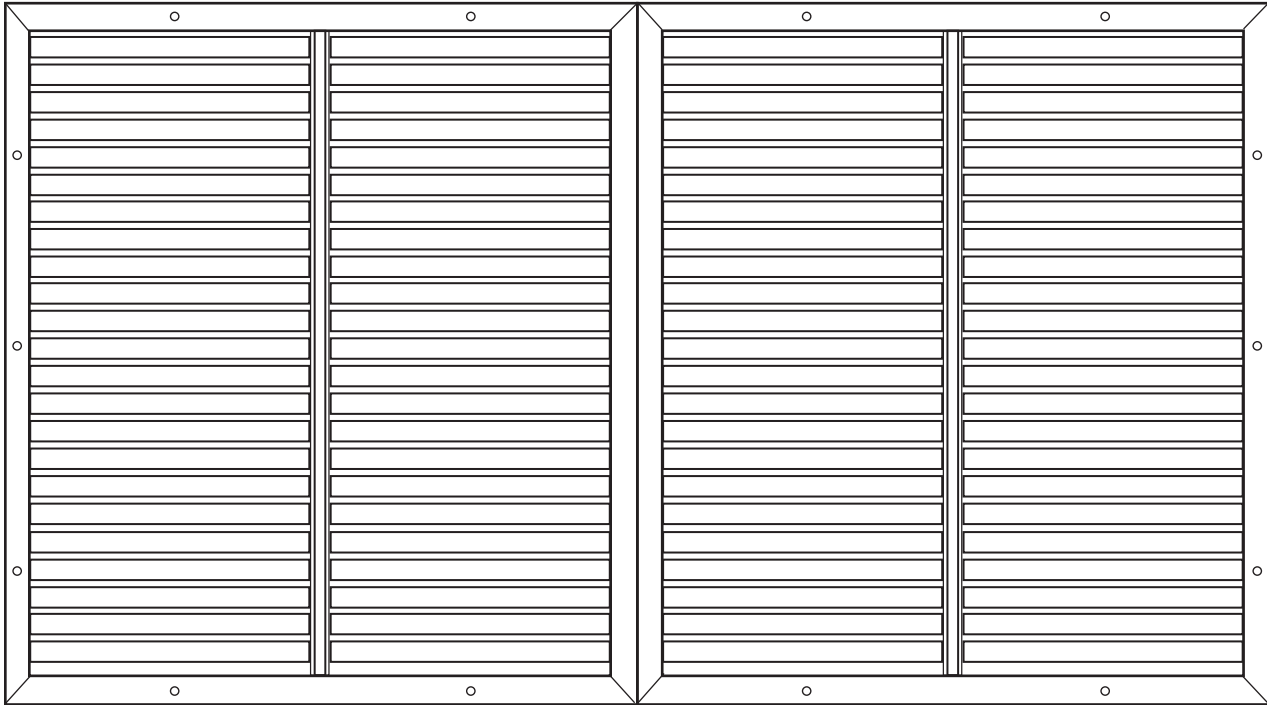
This warranty gives you specific legal rights and you may also have other rights which vary from state to state.

Some states do not allow the exclusion of limitation of incidental or consequential damages or limitation on how long an implied warranty lasts, so the above may not apply to you.



Large Grilles in Multiple Sections

No screw holes on interior joined frames by default
Screw holes can be added if clearly specified on order



Support required for proper installation by others
Not provided by Airvector

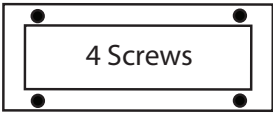
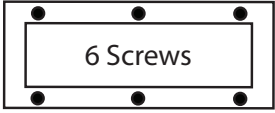

Notes

- Maximum section size: 46" x 36" (neck)
- Maximum width without mullion: 18"
- Larger grilles can be made in one piece, extra manufacturing and shipping charges apply

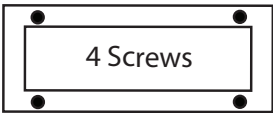
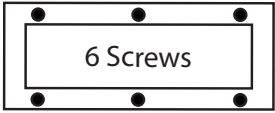
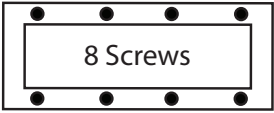
IGSA / GAA / ERE - Screw Holes Chart

		Width			
		4" to 17.9"	18" to 29.9"	30" to 47.9"	48" +
Height	4" to 17.9"	<p>2 Screws</p> <p>10" to 16" 4 Screws</p>	<p>4 Screws</p>	<p>6 Screws</p>	<p>8 Screws</p>
	18" to 21.9"	<p>4 Screws</p>	<p>6 Screws</p>	<p>8 Screws</p>	<p>10 Screws</p>
	22" to 29.9"	<p>4 Screws</p>	<p>8 Screws</p>	<p>10 Screws</p>	<p>12 Screws</p>
	30" to 47.9"	<p>6 Screws</p>	<p>10 Screws</p>	<p>12 Screws</p>	<p>14 Screws</p>
	48" +	<p>8 Screws</p>	<p>12 Screws</p>	<p>14 Screws</p>	<p>16 Screws</p>

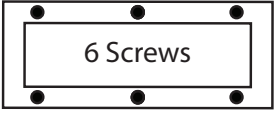
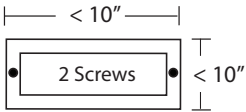

ALS - Architectural Linear Slot Diffusers

		Lenght		
		4" to 36"	37" to 48"	49" to 72"
Nb. of Slots	1 - 10	 <p>4 Screws</p>	 <p>6 Screws</p>	 <p>8 Screws</p>

ALF - Linear Flow Airflow Diffusers


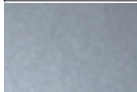


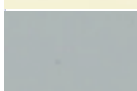




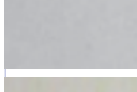
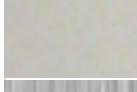
		Lenght		
		4" to 36"	37" to 48"	49" to 72"
Nb. of Slots	1 - 10	 <p>4 Screws</p>	 <p>6 Screws</p>	 <p>8 Screws</p>

ALB - Architectural Linear Bar Grilles & Registers

		Lenght	
		18" to 36"	37" to 72"
Width	1.5" - 15"	 <p>6 Screws</p>  <p>2 Screws</p> <p>< 10"</p> <p>< 10"</p>	 <p>8 Screws</p>

The current chart features standard finishes offered by Airvector® on most products. Colors and textures have been reproduced as accurately as possible. However, due to variances among computer monitors and printers, the colors may appear differently than on the actual products. Some finishes might not apply to all products. Extra costs and lead times have been listed

to help you price and schedule your orders. See RAL available on our RAL K7 Classic Colour Chart. For more accurate costs and lead times, to confirm availability of a finish on a particular product or for custom finish requirements, please contact our customer service department at order@airvector-hvac.com.

Preview	Color Name	Code	Extra Cost	Lead Time
	White Gloss level: low RAL: 9016	/W	Standard (no extra cost)	Standard 2 weeks Premium Services Available
	Silver Aluminum Gloss level: matte	/SI	15% - 20% adder	Standard 2 weeks Premium Services Available
	Off White Gloss level: medium RAL: 9010	/OW	15% - 20% adder	Standard 2 weeks Premium Services Available
	Beige Gloss level: high RAL: 1013	/BE	15% - 20% adder	Standard 2 weeks Premium Services Available
	Grey Gloss level: high	/G	15% - 20% adder	Standard 2 weeks Premium Services Available
	Brown Gloss level: matte	/BR	15% - 20% adder	Standard 2 weeks Premium Services Available
	Black Gloss level: medium	/BK	15% - 20% adder	Standard 2 weeks Premium Services Available
	Black Mat Gloss level: mat	/BM	15% - 20% adder	Standard 2 weeks Premium Services Available
	Brushed & Lacquered Gloss level: high	/L	15% - 35% adder	Standard 2 weeks Premium Services Available
	Colors from Tiger Drylac selection	/C	\$500 setup charge 15% - 35% adder	Minimum 4 weeks
	Mill (Raw Aluminum)	/M	Standard (no extra cost)	Standard 2 weeks Premium Services Available
	Anodized	/A	15% - 25% adder	Standard 2 weeks Premium Services Available
	Brushed Aluminum (No Lacquer)	/B	15% - 20% adder	Standard 2 weeks Premium Services Available

Powder Coated Paint

Other Finishes

FINISH CHART