

## Flush Surface-Matching

**Material:** Heavy gauge steel construction, aluminum core.  
**Mounting:** Surface or Plaster-in Frame (Tape & Spackle)

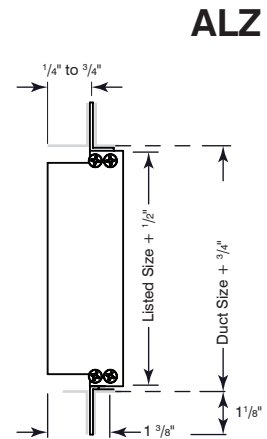
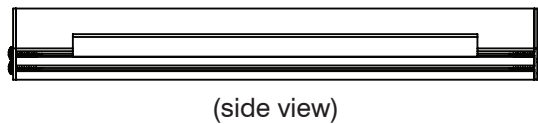
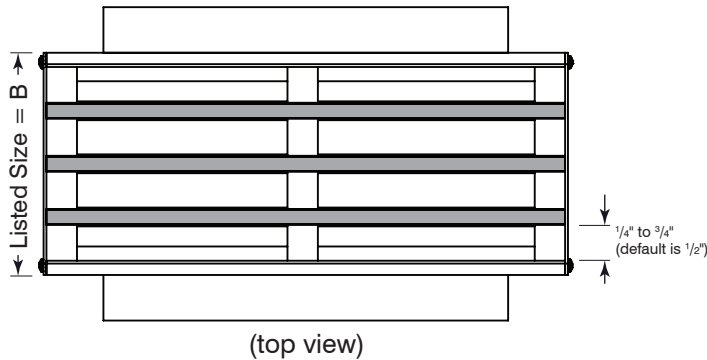
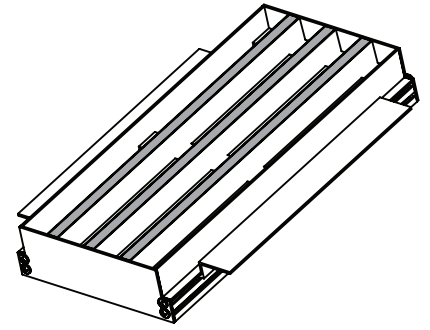

NO. OF SLOTS	(B)							
	1/4" Flooring Inserts				1/2" Flooring Inserts			
	Slot Width				Slot Width			
	1/8"	1/4"	3/8"	1/2"	1/8"	1/4"	3/8"	1/2"
03	19/16"	115/16"	25/16"	211/16"				
04	2"	21/2"	3"	31/5"				
05	27/16"	31/16"	311/16"	45/16"				
06	27/8"	35/8"	43/8"	51/8"	41/8"	47/8"	55/8"	63/8"
07	313/16"	41/4"	51/8"	6"	47/8"	53/4"	65/8"	71/2"
08	35/8"	413/16"	513/16"	613/16"	59/16"	69/16"	79/16"	89/16"
09					61/4"	73/8"	81/2"	95/8"

Finish		
<input type="checkbox"/> /BK Black (Default)	<input type="checkbox"/> /W White	<input type="checkbox"/> /C Custom (Please Specify)



Schedule type: \_\_\_\_\_

Job: \_\_\_\_\_

Architect: \_\_\_\_\_

Engineer: \_\_\_\_\_

Contractor: \_\_\_\_\_