

# ROUND DIFFUSERS



Rev. 1

## ADJUSTABLE ROUND DIFFUSER

**360° radial discharge pattern**

### MODELS DCL - Aluminum Adjustable Round Diffuser

The Airvector® **DCL** Aluminum Adjustable Round Diffusers are recommended for heating, ventilating, and cooling applications. **DCL** diffusers provide a 360° air diffusion pattern and excellent performance in VAV systems.

Full adjustability is possible by rotating the inner core clockwise or counterclockwise to move the cones up or down, changing from horizontal projection to vertical projection in accordance with the supply air temperature and reducing stratification. **DCL** diffusers provide great performance in temperatures differentials up to 54°F (12°C) and are suitable for premises with ceilings 8.5 ft (2.6 m) and higher.

#### KEY FEATURES

- Heavy-gauge aluminum construction
- Fully adjustable
- Powder paint coating - White (Custom Finishes Avail.)



**DCL**

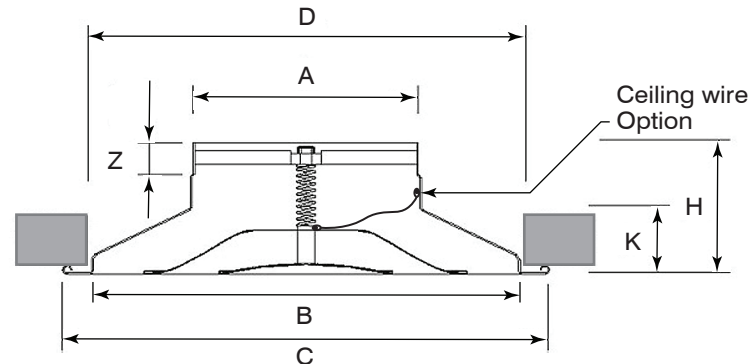

Model	Duct Size	A (in)	C (in)	B (in)	H (in)	D (in)	Z (in)
DCL 06	6"	5 11/16"	13 3/16"	11"	4 1/8"	11 5/16"	1"
DCL 08	8"	7 11/16"	16 11/16"	14 3/16"	4 11/16"	14 5/8"	1"
DCL 10	10"	9 5/8"	20 3/8"	17 1/2"	5 1/8"	18"	1"
DCL 12	12"	11 5/8"	25 3/16"	22"	5 11/16"	22 3/8"	1"
DCL 14	14"	13 5/8"	28 11/16"	25 3/16"	7 5/16"	25 5/8"	1"

Up to 14", pricing available upon request.

#### HOW TO ORDER DCG ROUND DIFFUSERS

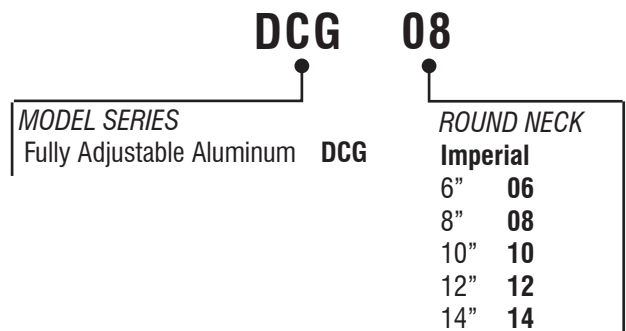

**DCL**  
**ADJUSTABLE ROUND DIFFUSER**

**Recommended Velocity and CFM**

Neck Diameter	Free Area (sqf)	Vmin (fpm)	Vmax (fpm)	Min cfm	Max cfm
6" (160 mm)	0.215	590	1122	126	241
8" (200 mm)	0.338	590	1142	200	388
10" (250 mm)	0.527	590	886	312	468
12" (315 mm)	0.839	590	1122	491	950
14" (355 mm)	1.035	590	1220	609	1279
16" (400 mm)	1.345	590	1181	794	1606
18" (450 mm)	1.711	590	886	917	1561
20" (500 mm)	2.110	590	886	1112	1858

**Isothermal Performance Data in Horizontal Flow Position**

SIZE	Neck Velocity (fpm)	400	500	600	700	800	1000	1200	1400	1600
	Velocity Pressure (in H <sub>2</sub> O)	.010	.016	.023	.031	.040	.063	.090	.122	.160
<b>6"</b> 160 mm	CFM	79	98	118	137	157	196	236	275	314
	Pressure Loss (in w.g.)	.032	.044	.060	.080	.104	.153	.241	.301	.402
	NC	< 15	< 15	< 20	20	< 20	30	< 35	> 35	> 35
	Throw - Radius (ft)	4	5	6	9	11	13	17	20	25
<b>8"</b> 200 mm	CFM	140	175	209	244	279	349	419	489	559
	Pressure Loss (in w.g.)	.028	.036	.056	.072	.096	.149	.209	.281	.361
	NC	< 15	< 15	< 20	30	< 35	< 35	35	> 35	> 35
	Throw - Radius (ft)	5	7	9	11	12	14	17	19	22
<b>10"</b> 250 mm	CFM	218	273	327	382	436	545	654	764	873
	Pressure Loss (in w.g.)	.040	.060	.092	.120	.161	.249	.402	.602	-
	NC	< 15	< 15	< 20	< 25	< 30	35	> 35	> 35	-
	Throw - Radius (ft)	7	9	11	13	15	20	25	33	-
<b>12"</b> 315 mm	CFM	314	393	471	550	628	785	942	1100	1257
	Pressure Loss (in w.g.)	.040	.056	.096	.129	.201	.309	.482	.703	-
	NC	< 15	< 20	< 30	30	< 40	> 40	> 40	> 40	-
	Throw - Radius (ft)	11	12	14	16	17	19	22	-	-
<b>14"</b> 355 mm	CFM	428	535	641	748	855	1069	1283	1497	1710
	Pressure Loss (in w.g.)	.032	.052	.072	.108	.149	.221	.361	.482	.602
	NC	< 15	20	25	< 30	< 35	< 40	> 40	> 40	> 40
	Throw - Radius (ft)	10	12	15	17	18	21	26	27	-
<b>Downward Projection of Heated Air (in ft)</b>	10 Degrees F Diff.	6 - 6	8 - 8	10 - 12	13 - 15	15 - 19	19 - 25	21 - 32	25 - 38	27 - 40
	20 Degrees F Diff.	4 - 4	6 - 7	7 - 8	9 - 11	10 - 14	13 - 18	15 - 17	17 - 25	19 - 29
	30 Degrees F Diff.	3 - 3	5 - 5	6 - 7	7 - 9	9 - 11	11 - 15	13 - 18	14 - 20	15 - 24
	40 Degrees F Diff.	3 - 2	4 - 4	5 - 6	7 - 8	8 - 10	10 - 13	11 - 16	12 - 18	14 - 20

**Performance Notes**

- NC value based on 10 db room attenuation
- Throw values are based on isothermal air and terminal velocity of 40 fpm
- For exposed duct application, multiply throw values by 0.7
- Downward Projection of Heated Air values represent the distance to a total air velocity of essentially zero. The two values are for 6" neck and 12" neck. In horizontal position.

# ADJUSTABLE ROUND DIFFUSER

## Vertical Flow Adjustment

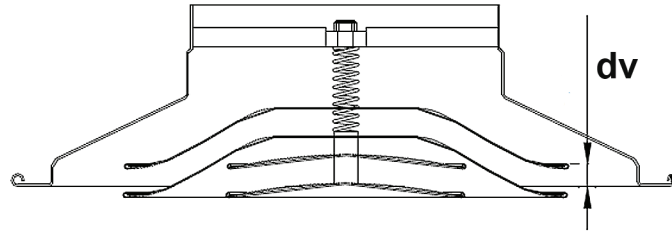

SIZE	Neck Velocity (fpm)	400	500	600	700	800	1000	1200	1400	1600
<b>6"</b> 160 mm	<b>CFM</b>	79	98	118	137	157	196	236	275	314
	dv = 13/64" (5 mm)	5 - x	7 - x	9 - x	11 - x	12 - 5	16 - 8	20 - 10	23 - 11	28 - 13
	dv = 5/16" (8 mm)	8 - x	10 - x	12 - 5	15 - 7	18 - 9	22 - 11	28 - 13	33 - 16	x - 19
	dv = 19/32" (15 mm)	12 - x	15 - 7	17 - 9	22 - 11	25 - 13	32 - 16	x - 19	x - 23	x - 28
<b>8"</b> 200 mm	<b>CFM</b>	140	175	209	244	279	349	419	489	559
	dv = 5/16" (8 mm)	9 - 3	11 - 5	12 - 7	13 - 8	14 - 9	17 - 10	19 - 11	x - 13	x - 14
	dv = 25/64" (10 mm)	12 - 7	14 - 8	16 - 9	17 - 11	18 - 11	22 - 13	25 - 15	x - 17	x - 18
	dv = 29/32" (23 mm)	16 - 10	19 - 11	21 - 13	24 - 14	25 - 15	31 - 18	33 - 20	x - 23	x - 25
<b>10"</b> 250 mm	<b>CFM</b>	218	273	327	382	436	545	654	764	873
	dv = 13/64" (5 mm)	11 - x	12 - 5	14 - 7	16 - 8	18 - 9	21 - 11	x - 13	x - 15	x - 18
	dv = 25/64" (10 mm)	15 - 7	17 - 9	20 - 11	22 - 12	25 - 13	30 - 15	x - 19	x - 22	x - 25
	dv = 45/64" (18 mm)	19 - 10	22 - 11	25 - 14	28 - 15	32 - 16	x - 20	x - 23	x - 28	x - 31
<b>12"</b> 315 mm	<b>CFM</b>	314	393	471	550	628	785	942	-	-
	dv = 33/64" (13 mm)	11 - 6	14 - 7	18 - 10	21 - 13	28 - 16	x - 19	x - 25	-	-
	dv = 25/32" (20 mm)	16 - 8	19 - 10	25 - 14	30 - 17	38 - 21	x - 27	x - 36	-	-
	dv = 1 1/16" (27 mm)	21 - 12	26 - 15	36 - 19	41 - 23	54 - 28	x - 38	x - 51	-	-
<b>14"</b> 355 mm	<b>CFM</b>	428	535	641	748	855	1069	1283	1497	-
	dv = 25/64" (10 mm)	7 - 3	9 - 6	12 - 8	15 - 9	18 - 11	21 - 15	30 - 19	x - 21	-
	dv = 19/32" (15 mm)	11 - 6	15 - 10	19 - 13	23 - 15	29 - 18	36 - 22	51 - 31	x - 36	-
	dv = 29/32" (23 mm)	18 - 10	22 - 15	30 - 19	36 - 23	44 - 27	59 - 35	x - 49	x - 56	-

**Performance Notes**

- Vertical throw values (in ft) are for isothermal (first value) and for a temperature difference of 9°F (5°C) in heating mode (second value), at terminal velocity of 40 fpm.
- **dv** is the vertical adjustment of the diffuser core and is measured by the core offset towards the inside of the diffuser, compared to its original horizontal position.
- **x** means the value is not available.

### How to Specify DCL Series

Supply and mounting of adjustable round diffuser series DCG, constructed from aluminum and powder coated in white M9016. Full vertical adjustability provided by rotating the core clockwise or counterclockwise.