

Oval Cable Operated Baffle Damper

- Material:** 22 gauge galvanized steel frame.
 16 gauge galvanized steel blade with gasket.
 1/2" dia. steel drive shaft.
- Mounting:** Drive cleat duct connection.
- Installation:** Horizontally, vertical or any angle.
 Operation not affected by position.

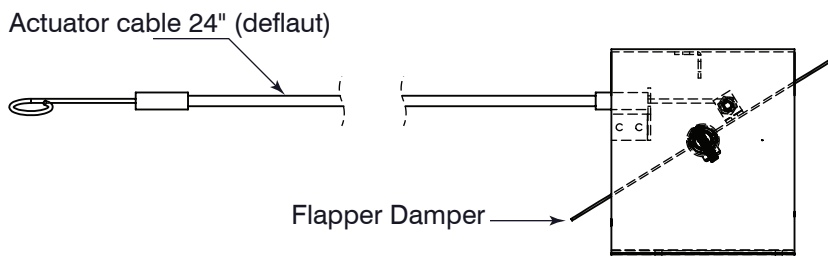

(Side View)

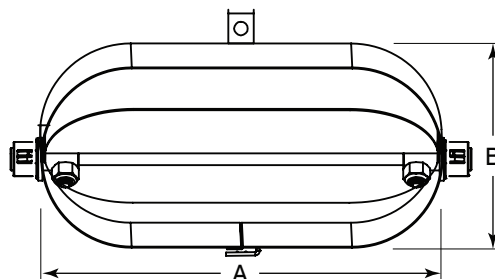

(Face View)

INSTALLATION

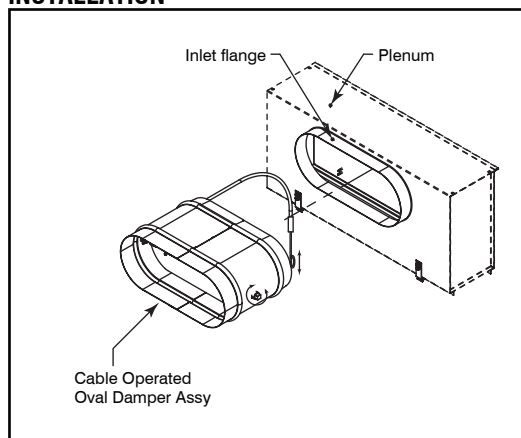

✓	Model #	Duct Size	Neck Size	
			A	B
	NCO 08	8"	9 3/8"	5 1/4"
	NCO 10	10"	12 1/2"	5 1/4"
	NCO 12	12"	14 1/8"	7 7/8"

✓	Cable Link Length Opt	
	-1	1 ft.
	-2 (Default)	2 ft.
	-3	3 ft.
	-4	4 ft.
	-5	5 ft.
	-6	6 ft.

Schedule type: _____

Job: _____

Architect: _____

Engineer: _____

Contractor: _____